

Visit

FREETESTPAPER.com

for more papers



Website: [freetestpaper.com](http://www.freetestpaper.com)



[Facebook.com/freetestpaper](https://www.facebook.com/freetestpaper)



[Twitter.com/freetestpaper](https://www.twitter.com/freetestpaper)



2024 PRIMARY 4 END-OF-YEAR EXAMINATION

Name : _____ ()

Date: 24 October 2024

Class : Primary 4 ()

Time: 8.00 a.m. - 9.30 a.m.

Duration: 1 hour 30 minutes

SCIENCE

BOOKLET A

INSTRUCTIONS TO CANDIDATES

1. Write your name, class and register number.
2. Do not turn over this page until you are told to do so.
3. Follow all instructions carefully.
4. Answer all questions.
5. Shade your answers on the Optical Answer Sheet (OAS) provided.

Booklet A (22 x 2 marks)

For each question from 1 to 22, four options are given. One of them is the correct answer. Make your choice (1, 2, 3 or 4) and shade your answer on the Optical Answer Sheet.

(44 marks)

1. Which of the following is a living thing?

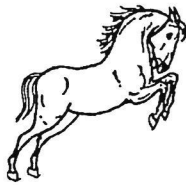

(1)



(2)

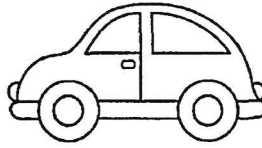

(3)

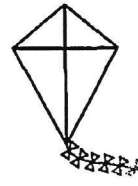

(4)

2. Which statement is true about most mammals?

- (1) They lay eggs.
- (2) They have wings.
- (3) They produce milk.
- (4) They have two legs.

3. In which part of the digestive system is water absorbed from undigested food?

- (1) gullet
- (2) stomach
- (3) large intestine
- (4) small intestine

4. The diagram below shows the life cycle of a plant.

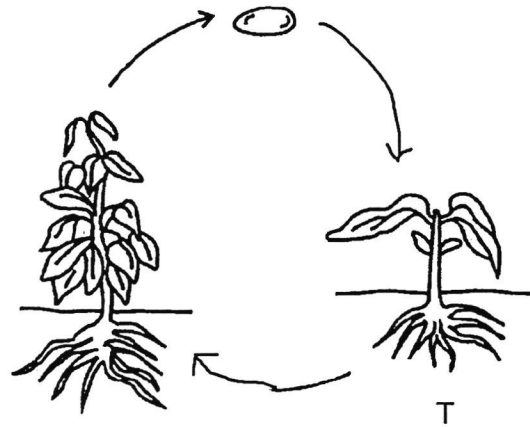

What is the stage marked T?

- (1) egg
 - (2) seed
 - (3) adult plant
 - (4) young plant
5. Which of the following can be attracted by a magnet?
- (1) steel rod
 - (2) glass rod
 - (3) rubber rod
 - (4) wooden rod
6. Which of the following has a fixed shape?
- (1) air
 - (2) oil
 - (3) water
 - (4) pencil

7. The set-up below shows a torch shining light on a wooden cube.

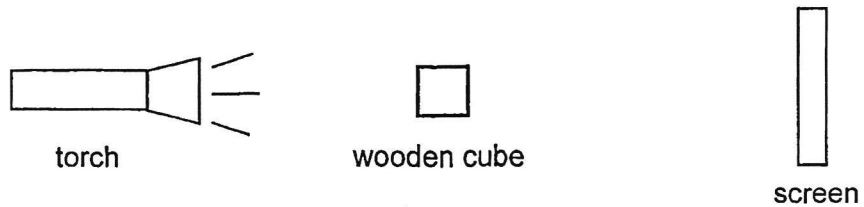



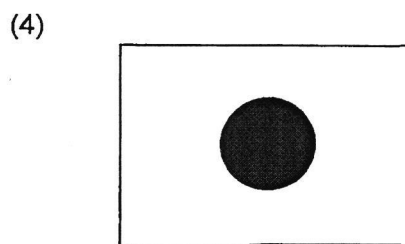
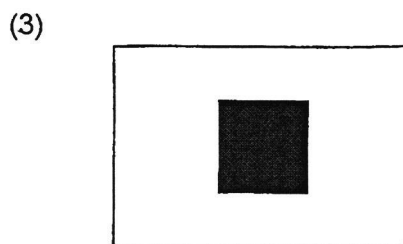
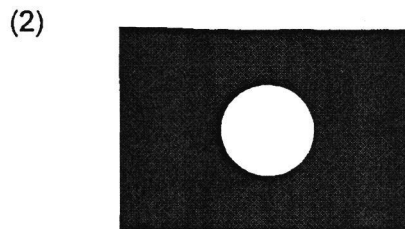
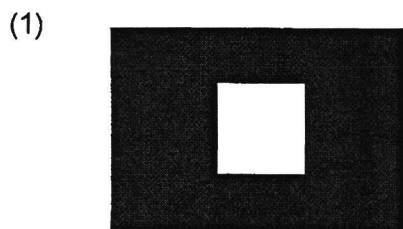

Which of the following would likely be seen on the screen?



8. Which of the following is a source of heat?

- (1) a leaf
- (2) a candle flame
- (3) a pair of gloves
- (4) a woollen sweater

9. Betty conducted an experiment to find out how the volume of water affects the growth of mould. She put four pieces of similar bread in the same room at 30°C. She poured different volumes of water on each bread. She recorded her observations as shown in the table below.

Bread	A	B	C	D
Volume of water (ml)	5	10	15	20
Observations of the bread after 2 weeks				

Based on her observations, which graph best represents the relationship between the volume of water and the amount of mould?

(1)

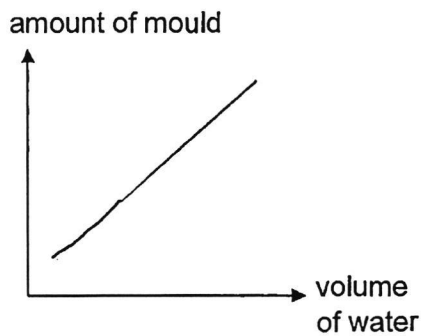

(2)

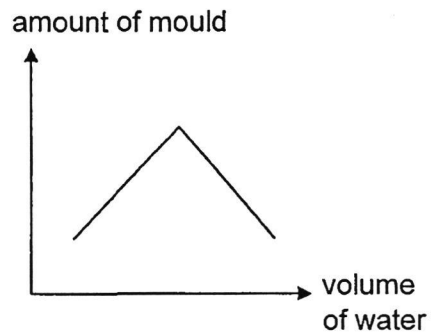

(3)

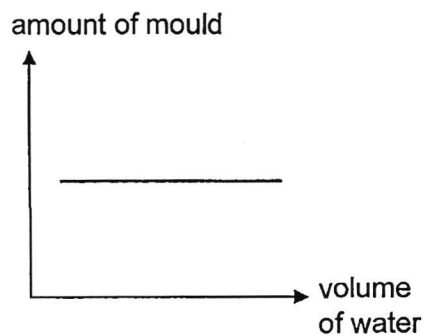

(4)

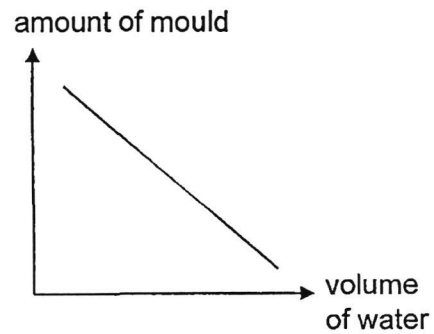

10. Which part, (1), (2), (3) or (4) holds the plant upright?

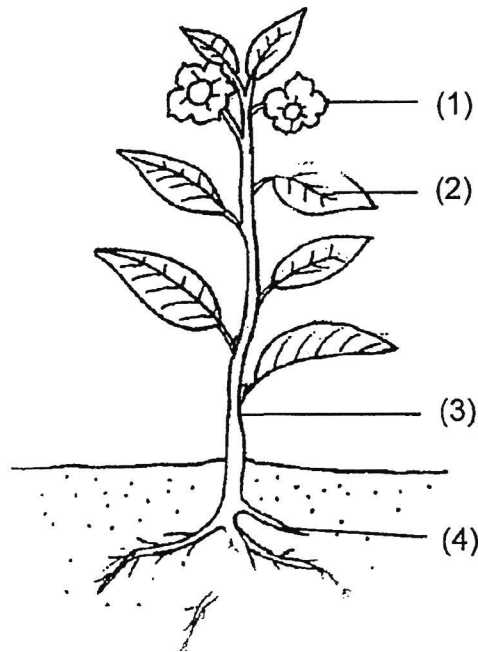

11. The bar graph below shows the amount of digested and undigested food just before it enters each organ in the human digestive system.

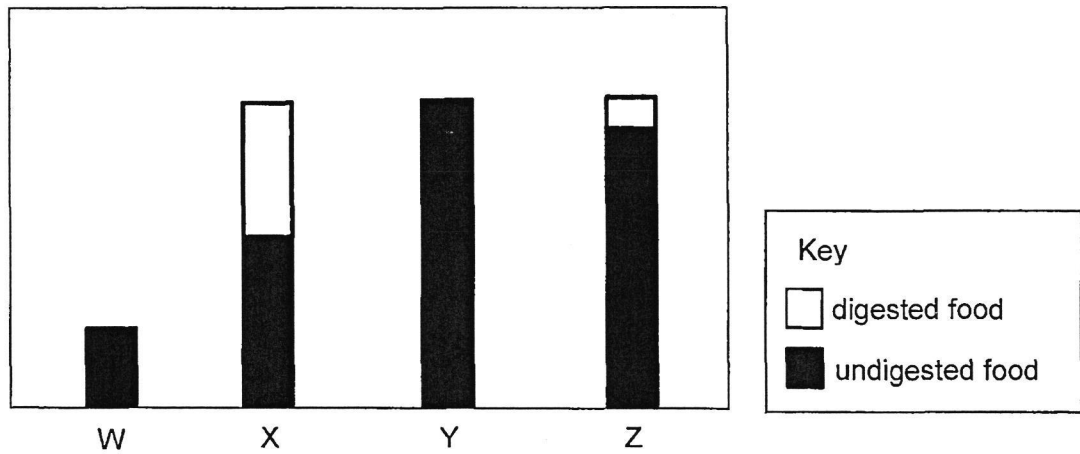

Which letter represents the stomach?

- (1) W
- (2) X
- (3) Y
- (4) Z

12. The graph below shows the number of days that animal A spent in the different stages of its life cycle.

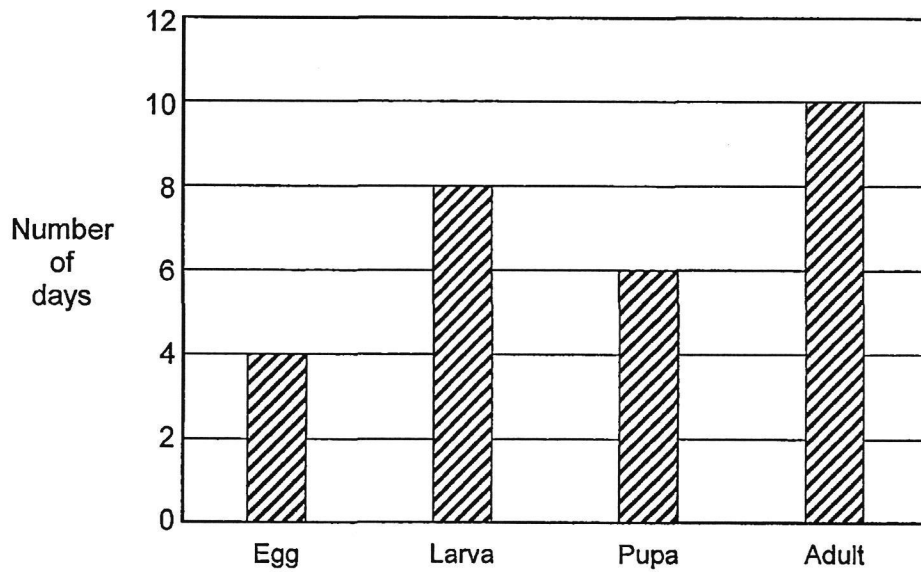

Based on the graph, which of the following statements about animal A is true?

- (1) It has three stages in its life cycle.
- (2) It does not feed on Day 13 of its life cycle.
- (3) It spends most of its life cycle in the larval stage.
- (4) It takes 10 days to become an adult after the egg has hatched.

13. Belinda sets up an experiment as shown below.

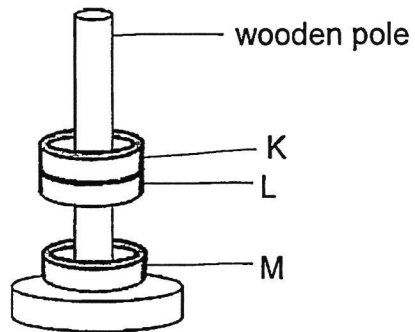

Based on the diagram above, which of the following statements is definitely false?

- (1) K is attracted to L.
- (2) Only L is a magnet.
- (3) M is a magnetic material.
- (4) Both K and M are magnets.

14. The diagram shows a container containing liquid X on the left side, with a stopper placed in the middle.

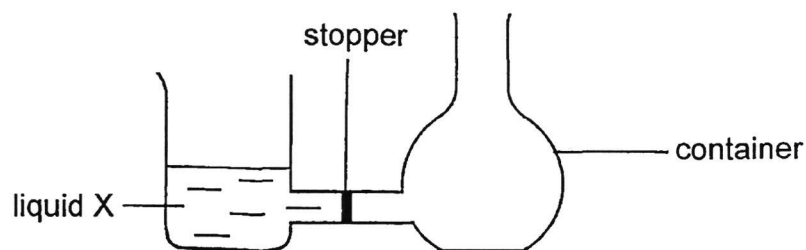

After the stopper is removed, liquid X is observed to move into the right side of the container as shown below.

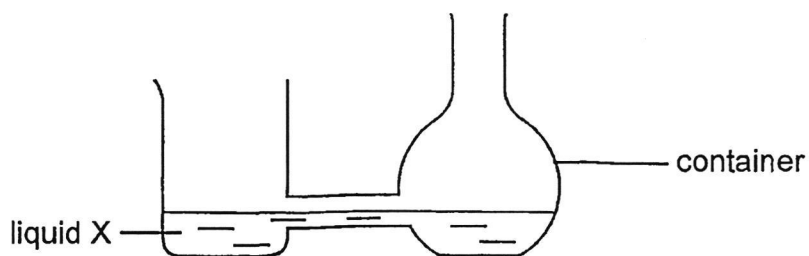

Which property of liquid X explains the observation above?

- (1) Liquid X has no mass.
- (2) Liquid X has no definite shape.
- (3) Liquid X has no definite volume.
- (4) Liquid X cannot be compressed.

15. Alice filled syringe A with 20 cm^3 of water and syringe B with 20 cm^3 of air.

Both syringes are connected to a container with a capacity of 200 cm^3 as shown below.

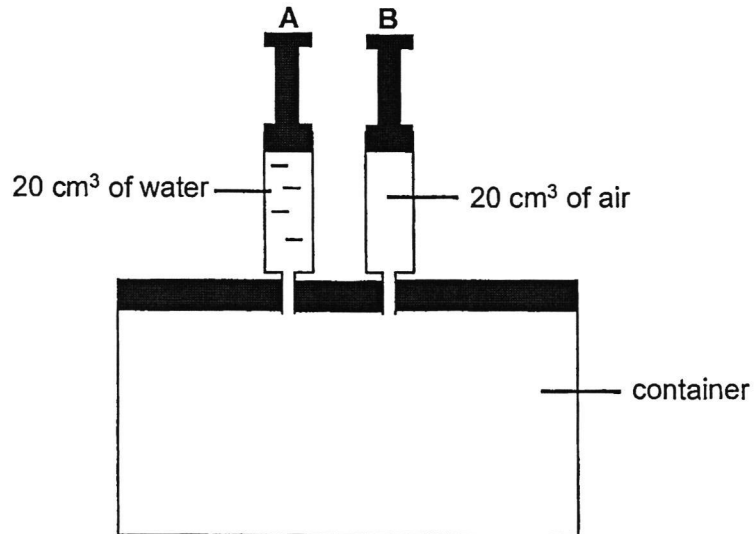

Alice pushed down the plungers fully so that all the water and air in the syringes are transferred to the container. Which of the following shows the correct volumes that the water and air occupied in the container at the end?

	Volume of water in the container (cm^3)	Volume of air in the container (cm^3)
(1)	20	20
(2)	20	180
(3)	40	160
(4)	0	200

16. Siti created a puppet using different materials for a shadow puppet play. Below shows the shadow created on the screen.

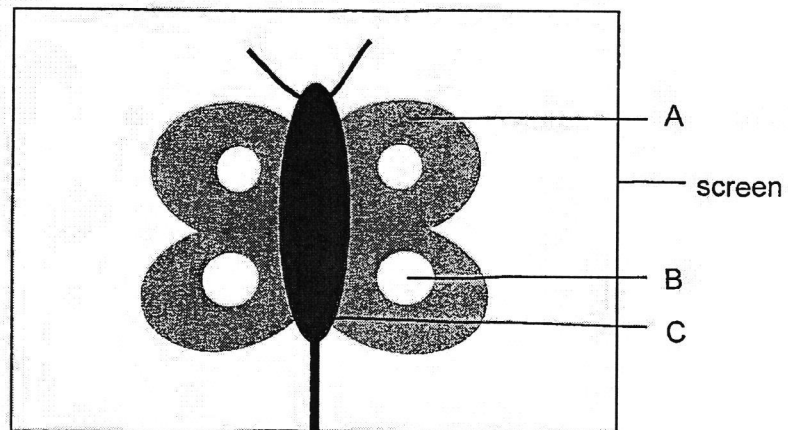

What are the possible materials A, B and C that Siti used to create the shadow above?

	A	B	C
(1)	tracing paper	clear plastic	wooden cardboard
(2)	clear plastic	tracing paper	wooden cardboard
(3)	clear plastic	wooden cardboard	tracing paper
(4)	wooden cardboard	tracing paper	clear plastic

17. In a dark room, light was shone on three wooden objects, P, Q and R.

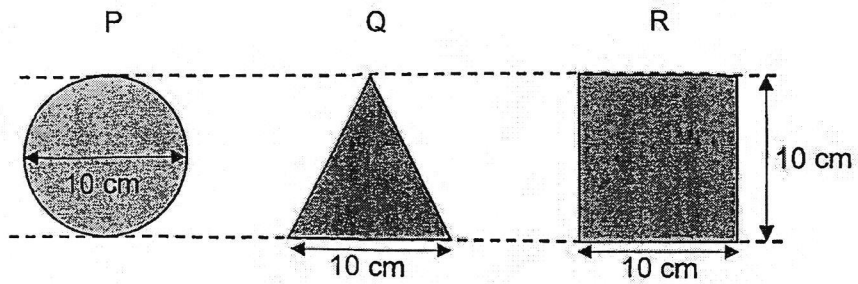

Each object is placed at different positions, X, Y and Z and a shadow is formed on the screen as shown below.

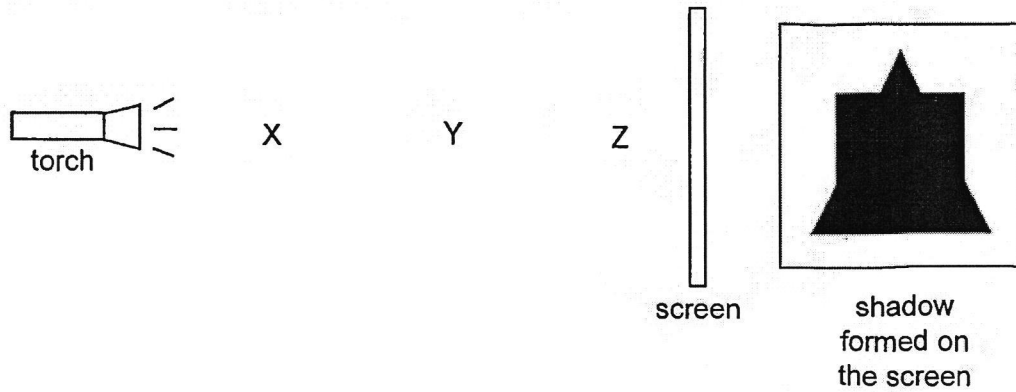

Which of the following shows the objects placed at correct positions X, Y and Z to form the shadow above?

	X	Y	Z
(1)	R	Q	P
(2)	P	R	Q
(3)	Q	P	R
(4)	Q	R	P

18. On a dark night, Emily placed 4 objects of similar size and shape at points V, W, Y and Z at different distances from the lamp post.

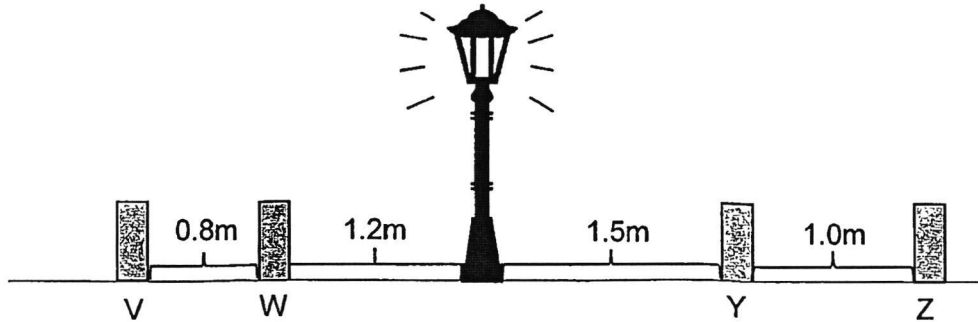

Which of the following graphs correctly shows the length of the objects' shadows at points V, W, Y and Z?

(1)

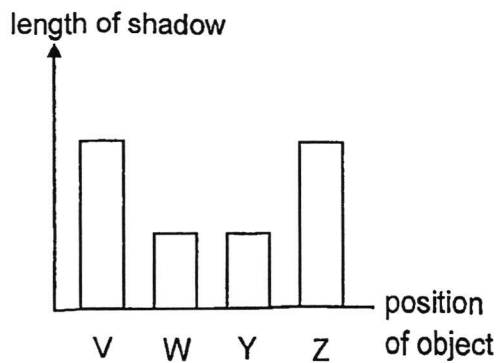

(2)

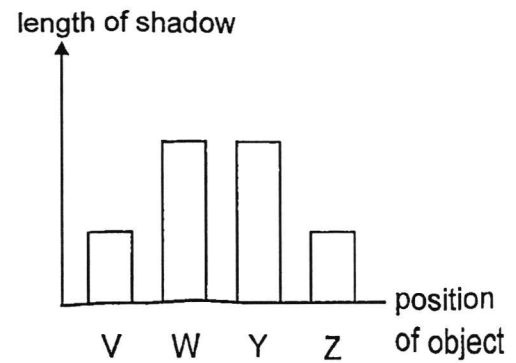

(3)

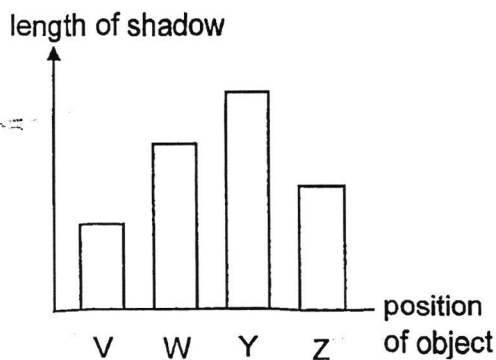

(4)

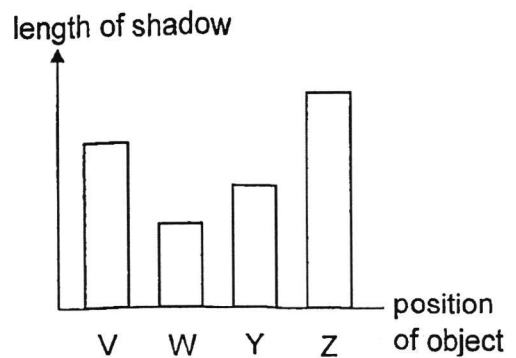

19. Rebecca added some ice cubes and a metal straw at room temperature of 30°C into a glass of cold water as shown below.

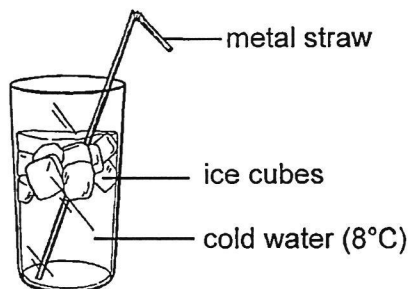

Which one of the following correctly describes her observations within the first 10 minutes?

	Change in temperature of the straw	Change in state of the ice cubes
(1)	increase	liquid to solid
(2)	decrease	liquid to solid
(3)	increase	solid to liquid
(4)	decrease	solid to liquid

20. The diagram shows the cable wires hanging loosely under the sun.

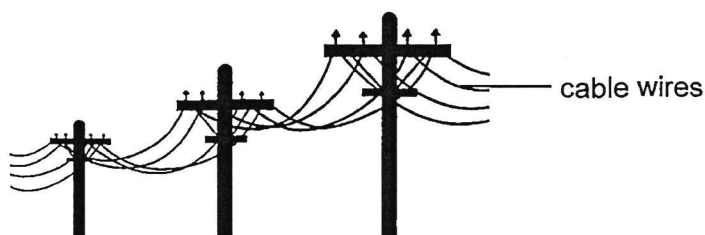

Which of the following statements about the cable wires is correct?

- (1) The cable wires lost heat to the sun and expanded.
- (2) The cable wires lost heat to the sun and contracted.
- (3) The cable wires gained heat from the sun and expanded.
- (4) The cable wires gained heat from the sun and contracted.

21. Paul puts his left foot in basin X and his right foot in basin Y for 2 minutes.



left foot in basin X



right foot in basin Y

Then, he puts both his feet into the water in basin Z. His left foot feels that the water is warm while his right foot feels that the water is cold.

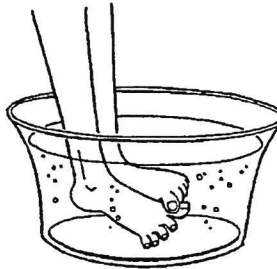

both feet in basin Z

Which of the following are the likely temperatures of water in basins X, Y and Z?

	Basin X (°C)	Basin Y (°C)	Basin Z (°C)
(1)	15	30	45
(2)	15	45	30
(3)	30	15	45
(4)	45	15	30

22. Hafiz wants to separate two cups that are stuck together.

Which of the following set-ups should he use to separate them?

(1)

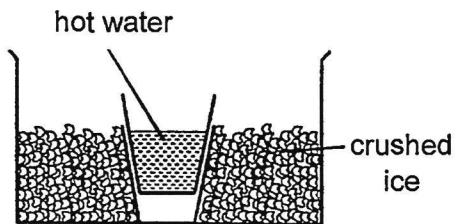

(2)

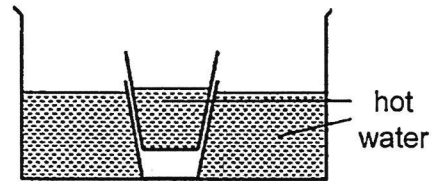

(3)

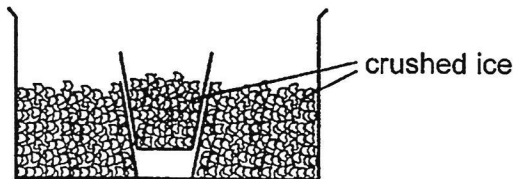

(4)

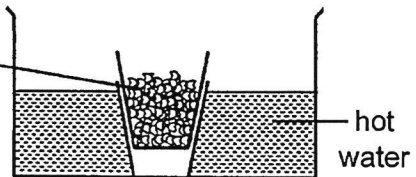

End of Booklet A



2024 PRIMARY 4 END-OF-YEAR EXAMINATION

Name : _____ ()

Date: 24 October 2024

Class : Primary 4 ()

Time: 8.00 a.m. - 9.30 a.m.

Duration: 1 hour 30 minutes

SCIENCE

BOOKLET B

INSTRUCTIONS TO CANDIDATES

1. Write your name, class and register number.
2. Do not turn over this page until you are told to do so.
3. Follow all instructions carefully.
4. Answer all questions.
5. Write your answers in the booklet.

Booklet A	44
Booklet B	36
Total	80

Booklet B (36 marks)

For questions 23 to 34, write your answers clearly in this booklet.

The number of marks available is shown in brackets [] at the end of each question or part question.

(36 marks)

23. Study the classification chart below.

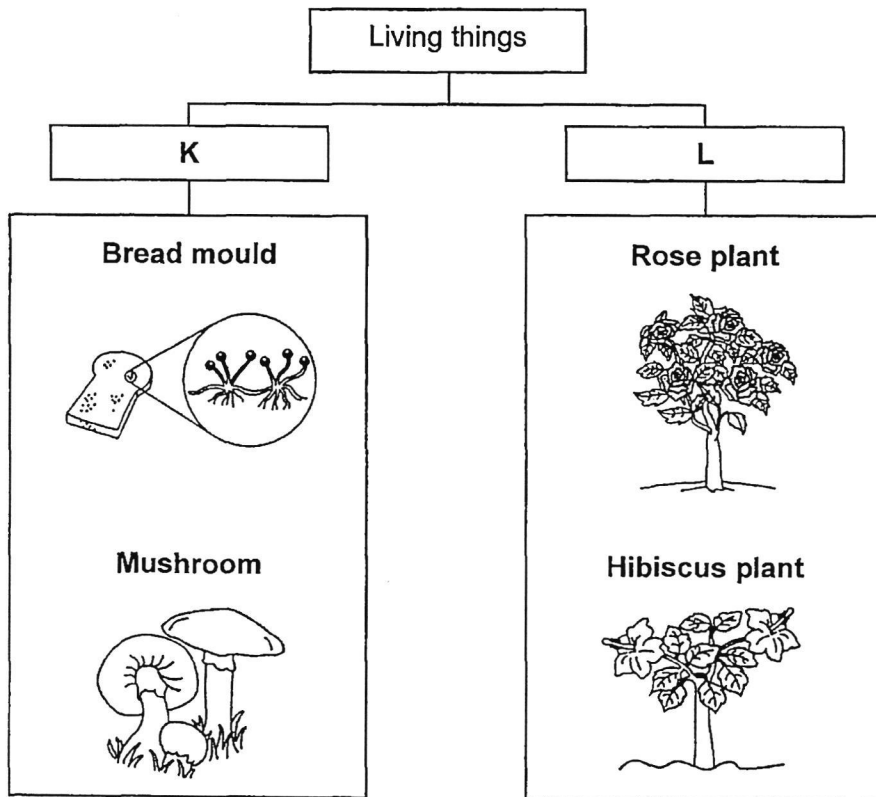

Choose the correct words from the box to give suitable headings for **K** and **L**. [2]

flowering plants	non-flowering plants	fungi	bacteria
------------------	----------------------	-------	----------

K: _____

L: _____

Score	0 / 2
-------	-------

24. Fill in the correct parts of a plant in the table. [2]

	Function of a plant part	Plant part
(a)	It makes food for the plant.	
(b)	It holds the plant firmly to the ground.	

25. The picture below shows a cup of tea.

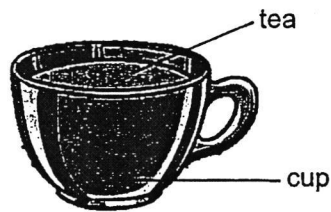

Circle the correct state of the following things. [2]

(a) tea: solid / liquid / gas

(b) cup: solid / liquid / gas

26. The diagram below shows how Mr Lee sees a tree. [2]

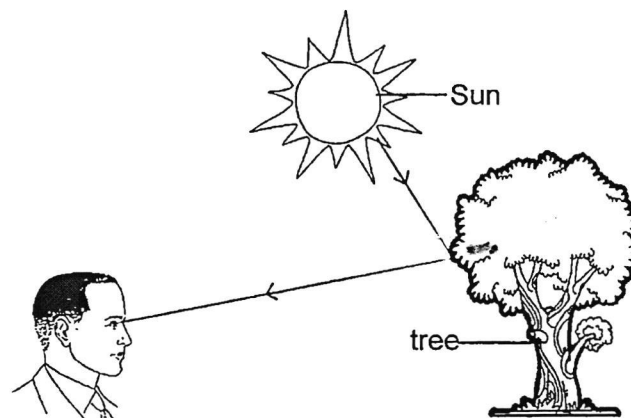

The _____ from the Sun is _____ by the tree and enters Mr Lee's eyes.

27. Sally used four identical slices of bread, W, X, Y and Z, in an experiment. She cut each slice of bread into different number of smaller pieces and placed them into four identical beakers filled with equal amount of liquid Q as shown below.

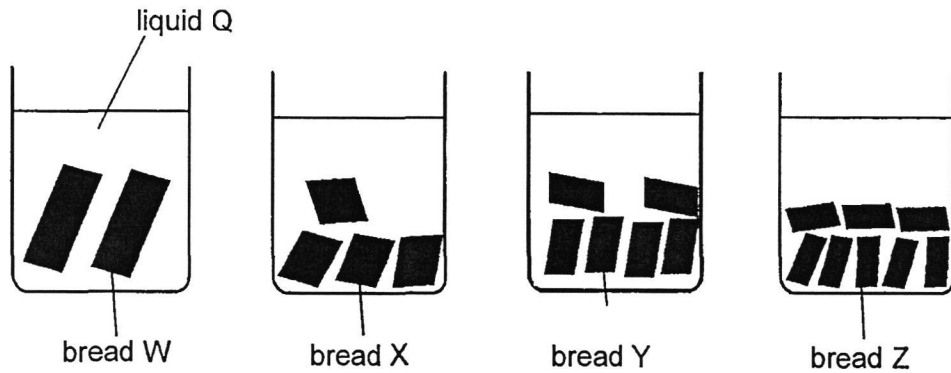

Sally noticed that the pieces of each bread started breaking down and recorded the time taken for the bread to be completely broken down into simpler substances.

Bread	Number of pieces each bread was cut into	Time taken for the bread to be completely broken down (min)
W	2	45
X	4	40
Y	6	32
Z	8	28

- (a) What could liquid Q be? [1]

- (b) What is the relationship between the number of pieces each bread was cut into and the time taken for the bread to be completely broken down? [1]

- (c) After the experiment, Sally concluded that chewing of food is helpful to digestion. Explain why. [2]

28. The diagram below shows the life cycle of a grasshopper.

- (a) Name the stages in the life cycle of a grasshopper. [1]

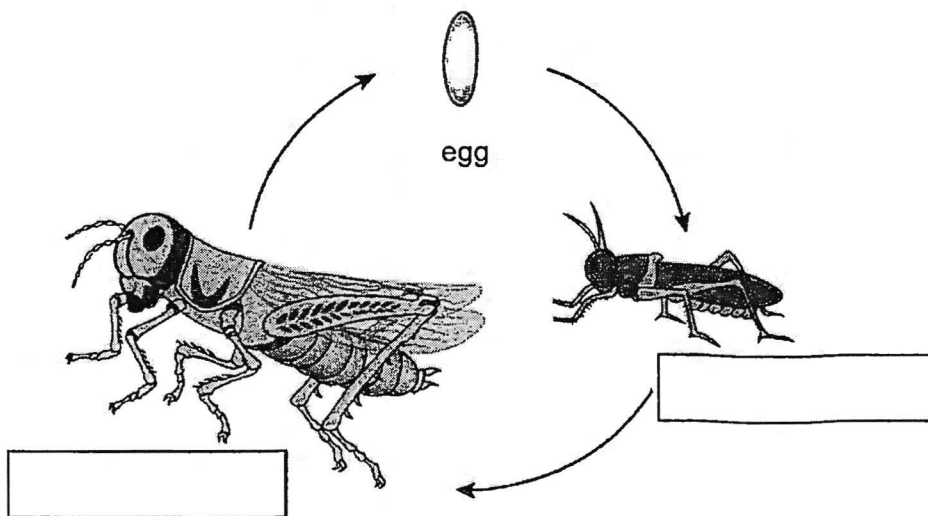

- (b) Why does a female grasshopper lay many eggs at a time? [1]

29. Study the life cycle of the animals shown below.

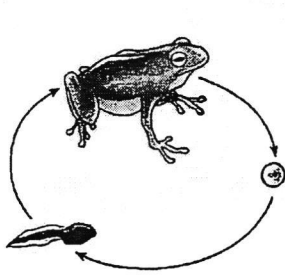

life cycle of a frog

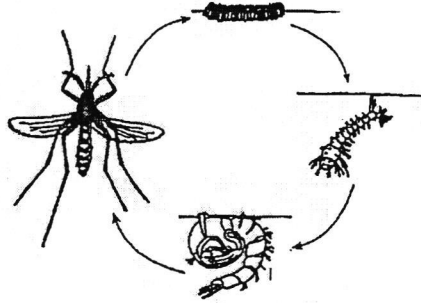

life cycle of a mosquito

(a) State one similarity and one difference between the two life cycles shown above. [2]

Similarity: _____

Difference: _____

After a rain, water is often found in the holes of bamboo pole holders outside the windows.

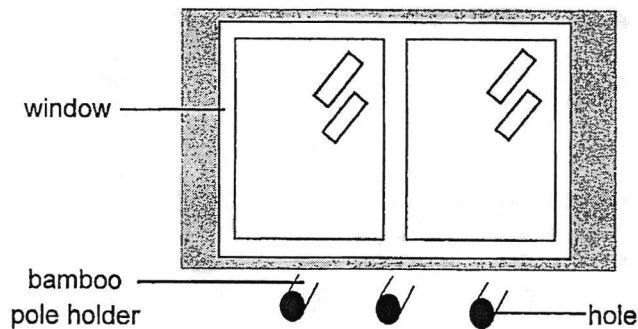

(b) Based on the life cycle of a mosquito, explain why it is important to cover the holes of the bamboo pole holders. [2]

30. Steve has a new bottle of bubble solution as shown below. He poured some of the solution into a container until it was filled to the brim. Then he submerged the mouth of the bubble gun into the container until it touched the base of the container.

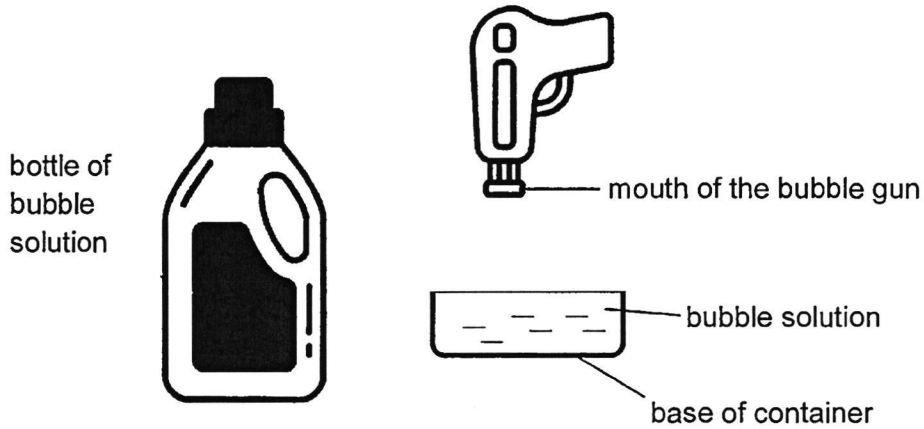

- (a) What would Steve observe when he submerged the mouth of the bubble gun into the container of bubble solution? [1]

- (b) Explain your answer in (a). [1]

- (c) Whenever Steve used up the bubble solution in the container, he refilled it with the bottle of bubble solution. After several rounds of refilling, he realised that the bottle felt lighter. Explain why using a property of matter. [2]

31. Joy carried out an experiment to investigate the amount of light passing through three different materials, A, B and C.

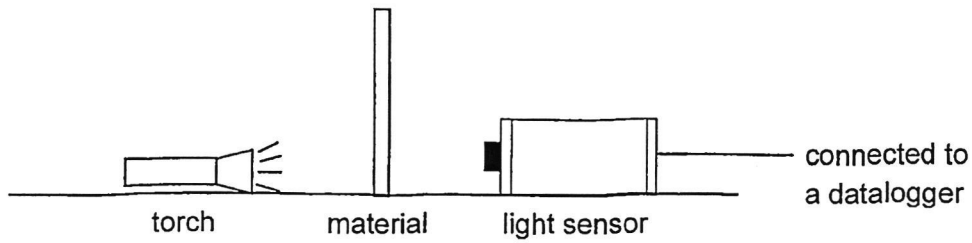

The results of her experiment detected by the light sensor are shown below.

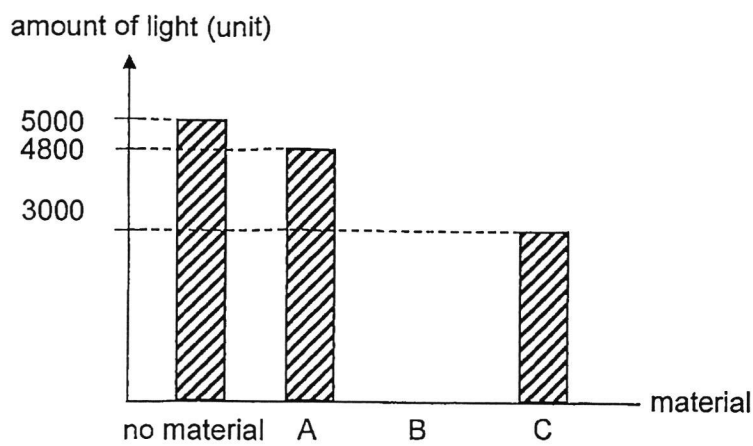

- (a) Based on the above readings, what can you conclude about the property of material A? Explain why. [1]

- (b) What can Joy do to ensure that her results are reliable? [1]

(c) Joy wants to buy stage curtains for the school hall.

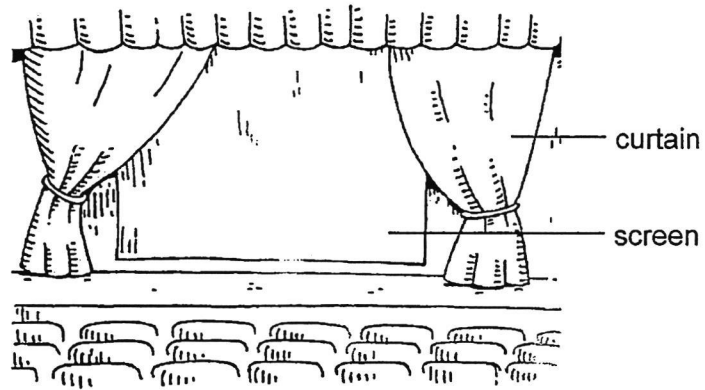

Based on the results, which material, A, B or C, should she buy for the stage curtains? Explain why. [2]

32. An electromagnet is set up as shown below.

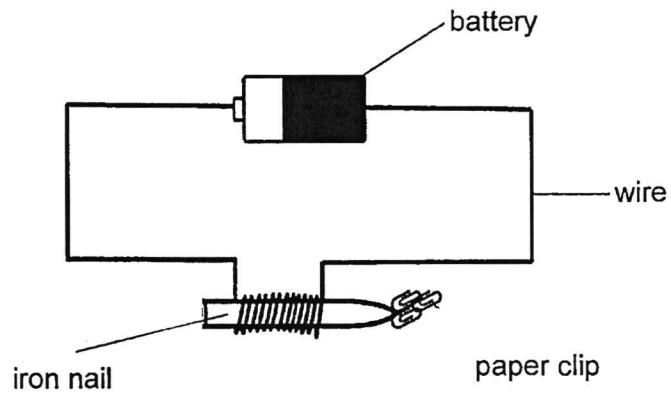

What are the two ways to increase the number of paper clips attracted by the iron nail? [2]

1. _____

2. _____

Score	4
-------	---

33. Jerome wanted to find out the fastest way to cook fishballs in a pot of hot soup. Uncooked fishballs sink to the bottom of the pot. Once they are cooked, the fishballs float.

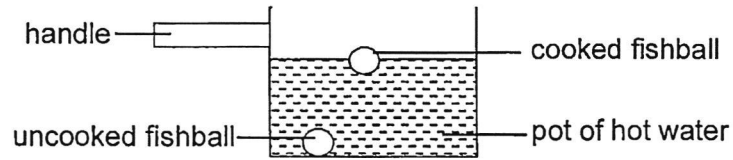

Jerome conducted an experiment using the four set-ups, W, X, Y and Z. Four identical uncooked fishballs were placed into a beaker of hot water as shown below. He recorded the time taken for each fishball to float to the surface.

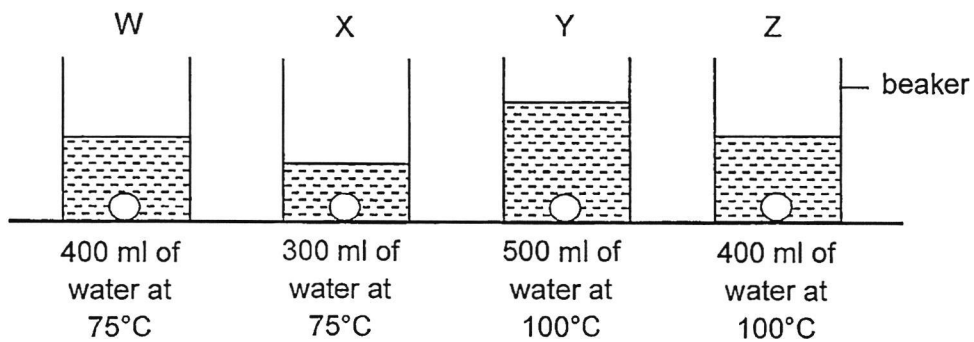

- (a) In the table above, write in the box a possible time taken for the fishball to float in set-up Z. [1]

Set-up	Time taken for the fishball to float (s)
W	200
X	240
Y	120
Z	<input type="text"/>

- (b) Based on the table, the fishball cooked the fastest in set-up Y.
Explain why. [2]

- (c) Give an example of a suitable material to make the handle of the pot so that Jerome will not burn his hands when he holds it. [1]

34. Taufik wanted to find out which bar made of material, P, Q, R or S, is the best conductor of heat. He put an identical ice cube at the end of each bar and heated the bar over a flame. He measured the volume of water collected in the beaker after 1 minute.

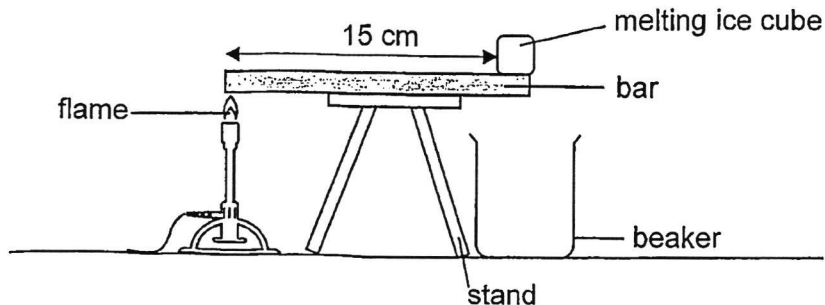

He repeated this experiment for each of the materials and recorded the results in the table below.

Material	Volume of water collected in the beaker (ml)
P	8
Q	6
R	3
S	10

- (a) State one other variable that must be kept constant for a fair test. [1]

- (b) Arrange the material from the best conductor of heat to the poorest conductor of heat. [1]

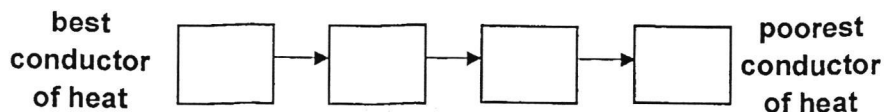

Taufik wanted to make a cooler box to keep ice cream cold for the longest time.

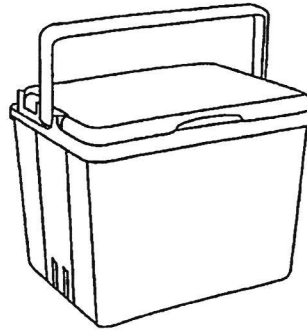

- (c) Based on the results of his experiment, which material, P, Q, R or S would be most suitable as a cooler box? Explain why. [2]

End of Paper

SCHOOL : TAO NAN PRIMARY SCHOOL

LEVEL : PRIMARY 4

SUBJECT : SCIENCE

TERM : 2024 SA2

CONTACT :

Q1	Q2	Q3	Q4	Q5	Q6	Q7	Q8	Q9	Q10
1	3	3	4	1	4	3	2	1	3

Q11	Q12	Q13	Q14	Q15	Q16	Q17	Q18	Q19	Q20
4	2	2	2	2	1	4	4	4	3

Q21	Q22
2	4

FREETESTPAPER.com

for more papers

Visit

FREETESTPAPER.com

for more papers

Tao Nan School
P4 Science End-of-Year Examination 2024
Simplified Answer Key (Booklet B)

Name: _____ ()

Class: 4 _____

This answer key only serves as a reference. Variations of students' answers have been accepted if they have shown conceptual understanding.

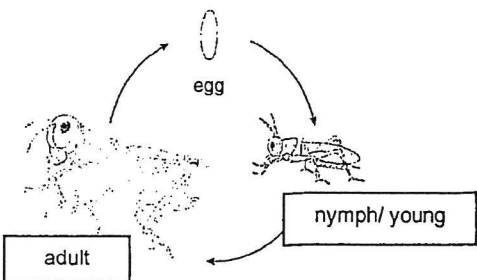
Qn	Suggested Answer
23	K: fungi L: flowering plant
24	(a) leaf / leaves (b) root(s)
25	(a) liquid (b) solid
26	light; reflected
27a	digestive juice(s) / saliva / gastric juice
b	As the number of pieces each bread was cut into increases, the time taken for the bread to be completely broken down decreases. (vice versa)
c	Chewing breaks food down into smaller pieces, so there is more exposed surface area of the food to digestive juice and food will be digested faster / digested in a shorter time.
28a	
b	A female grasshopper lays many eggs at a time to increase the chance of the eggs hatching / growing into nymph / becoming an adult.
29a	<p><u>Similarity</u> Both young do not resemble / look like the adult. Both have an egg/adult stage. Both the egg/young stage are found in water.</p> <p><u>Difference</u> The frog has a 3-staged life cycle but the mosquito has a 4-staged life cycle. The mosquito has a larval / pupal stage but the frog does not.</p>
b	This prevents water from entering / collecting in the holes so that the mosquitoes cannot lay eggs.

30a	The bubble solution will overflow / spill out.
b	The bubble gun takes up the space previously occupied by the bubble solution. / The bubble gun has displaced the bubble solution
c	After several rounds of refilling, the bottle feels lighter because there is less bubble solution and the mass of the bubble solution decreased.
31a	Material A allows most light to pass through.
b	She can redo/repeat the experiment/test.
c	[Claim] Material B. [Evidence] No light can pass through material B. [Reason] Curtains made of material B will not allow the audience to see the screen/the performers behind the curtains when the curtains are down.
32	Increase the number of batteries Increase the number of coils of wire around the iron nail.
33a	<i>Any number between 120 and 200</i>
b	Set-up Y has the most amount of water at the highest/higher temperature [Evidence]. Hence, the fishball will gain heat from the hot soup the fastest [Reason].
c	Plastic/Rubber/Wood. (or any other poor conductor of heat)
34a	Distance between the flame and bar/material <i>or</i> The position of the flame from the ice cube <i>or</i> Thickness/length of the material/bar <i>or</i> Intensity of the flame
b	S, P, Q, R
c	[Claim] Material R. [Evidence] The amount of water collected in the beaker is the least/ R is the poorest conductor of heat/R gains heat the slowest. [Reason] so the ice cream will gain heat the slowest from the material/surroundings.