

*Visit*

**FREETESTPAPER.com**

*for more papers*



Website: [freetestpaper.com](http://www.freetestpaper.com)



[Facebook.com/freetestpaper](https://www.facebook.com/freetestpaper)



[Twitter.com/freetestpaper](https://www.twitter.com/freetestpaper)

Pel Chun Public School  
Semestral Assessment 1 – 2017  
Science  
Primary 5

Name : \_\_\_\_\_ (     )

Date : 9 May 2017

Class : Pri. 5 (     )

Science Teacher : \_\_\_\_\_

Time : 1 h 35 min

**Section A (28 × 2 marks)**

For questions 1 to 28, choose the most suitable answer and shade its number (1, 2, 3 or 4) on the Optical Answer Sheet (OAS) provided.

1. Three bar magnets, AB, CD and EF, can be arranged as shown below.

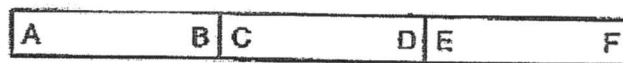

Which of the following arrangements of the magnets is not possible?

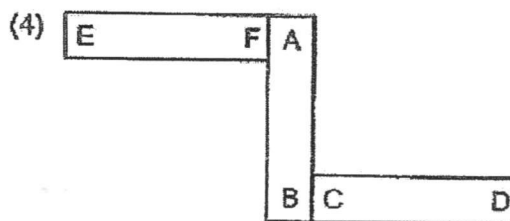
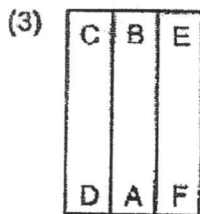
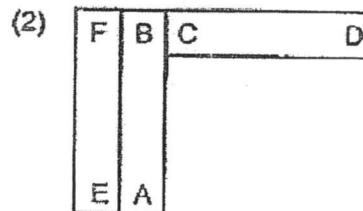
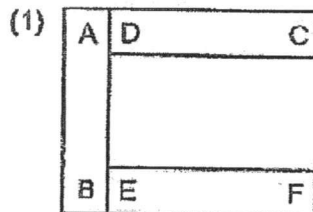

2. Lifang tried to magnetise a steel nail using the stroke method. She stroked the steel nail with a bar magnet as shown below. When she brought the steel nail near some paper clips, nothing happened.

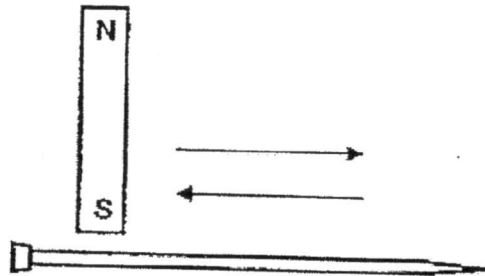

Which of the following could be the possible reason for her observation?

- (1) The bar magnet was too small.
  - (2) Steel is not a magnetic material.
  - (3) The steel nail was stroked in more than one direction.
  - (4) The steel nail was not stroked with the North pole of the magnet.
3. Yan Ling conducted an experiment using the set-up below.

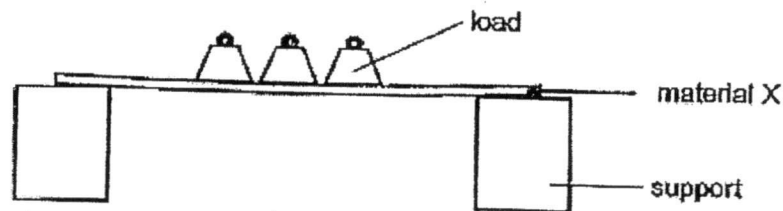

She increased the number of loads until material X broke.

The aim of her experiment was to find out \_\_\_\_\_.

- (1) how strong the load was
  - (2) how heavy the load was
  - (3) how strong material X was
  - (4) how flexible material X was
4. Which of the following is not a function of the human skeletal system?
- (1) Protects the internal organs.
  - (2) Supports the body and gives it shape.
  - (3) Works with the muscular system to enable the body to move.
  - (4) Transports waste material away from different parts of the body.

5. The diagram below shows the human digestive system.

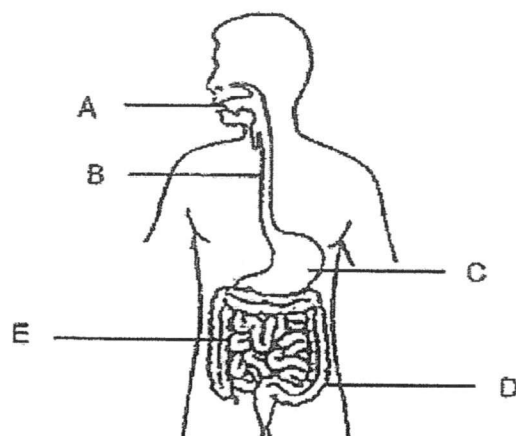

Where does digestion take place?

- (1) C and E only
  - (2) C, D and E only
  - (3) A, C and E only
  - (4) A, B, C and E only
6. The diagram below shows a sealed container. It has a capacity of  $500 \text{ cm}^3$  and currently contains  $150 \text{ cm}^3$  of water.

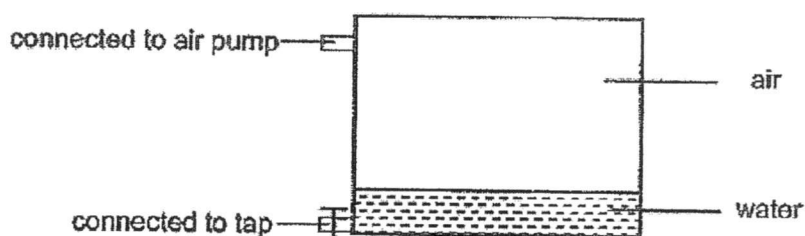

After  $50 \text{ cm}^3$  of water was removed and an additional  $100 \text{ cm}^3$  of air was pumped into the container, which of the following correctly shows the volume of air in the container?

- (1)  $350 \text{ cm}^3$
- (2)  $400 \text{ cm}^3$
- (3)  $450 \text{ cm}^3$
- (4)  $500 \text{ cm}^3$

7. The diagram below shows a beaker containing two substances, A and B.

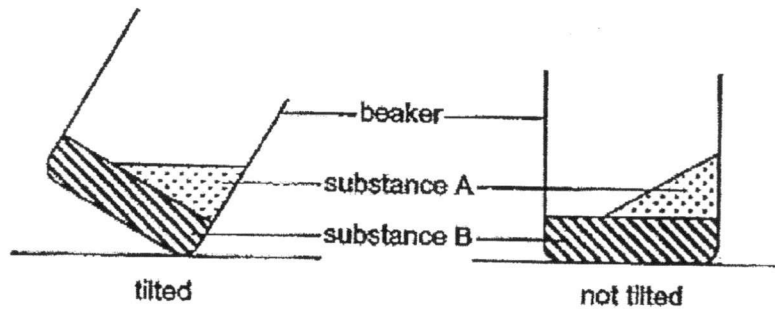

Based on your observations, which of the following correctly represents the state of matter of substances A and B?

	Substance A	Substance B
(1)	liquid	solid
(2)	solid	liquid
(3)	liquid	liquid
(4)	solid	solid

8. The graph below shows the number of days for each stage of the life cycle of insect Y.

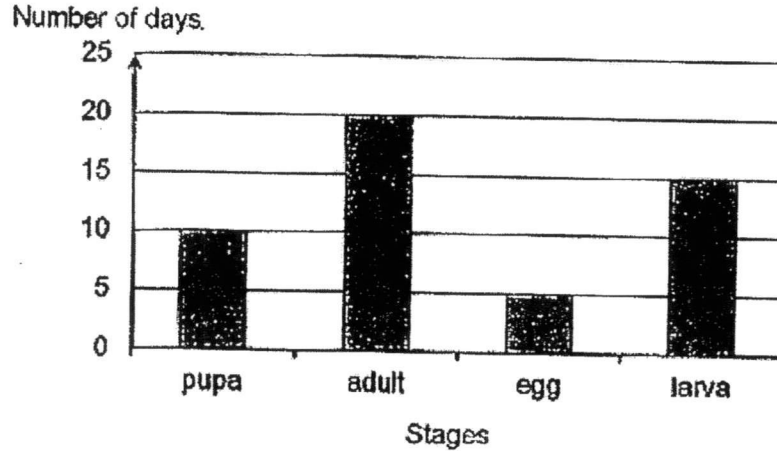

Based on the graph, which stage of the life cycle will insect Y be in 18 days after the egg has hatched?

- (1) egg
- (2) larva
- (3) pupa
- (4) adult

9. Jeremy wants to find out if light is needed for seeds to germinate. The table below contains information on set-ups A, B, C, D, E and F. Each set-up contains the same number of seeds.

Set-up	Temperature of surrounding (°C)	Presence of water	Presence of light
A	0	✓	
B	0	✓	✓
C	30	✓	✓
D	30		✓
E	30	✓	
F	30		

Which two set-ups should Jeremy choose to ensure a fair test?

- (1) A and B
- (2) A and C
- (3) C and E
- (4) D and F

10. The diagram below shows two sheets, S and T, with a shape cut out in the centre. Both are made of different materials.

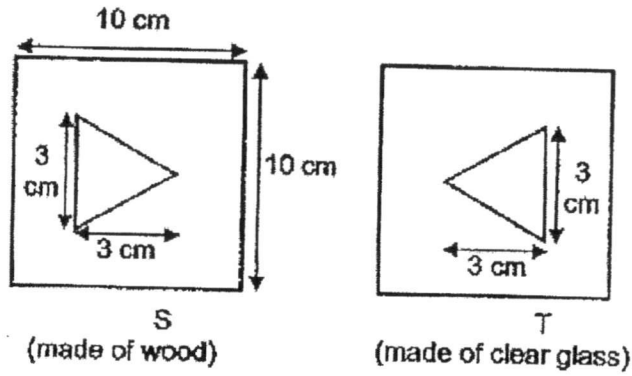

The sheets were then glued together and light was shone at them.

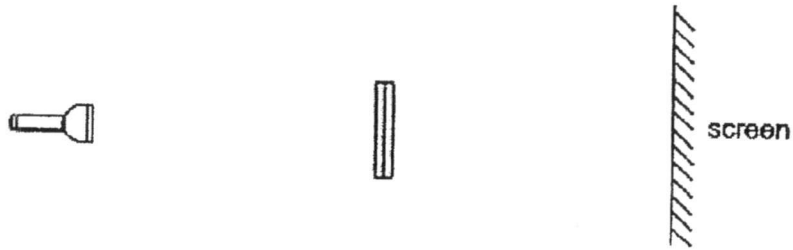

Which of the following correctly shows the shadow formed on the screen?

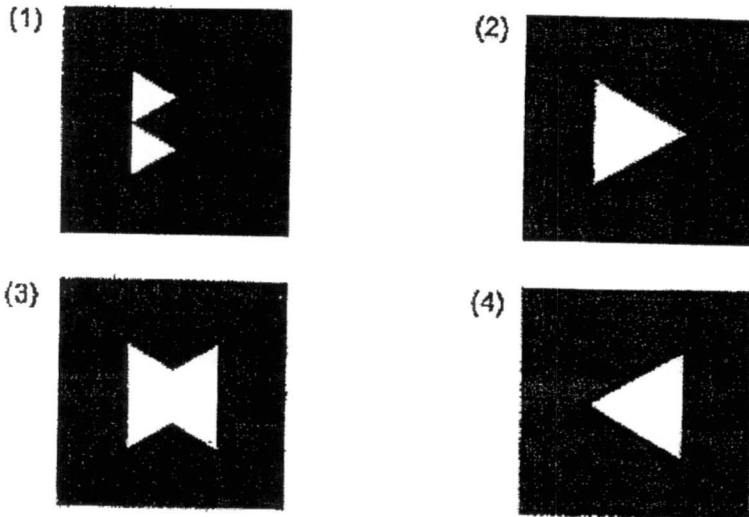

11. Mary walked in a straight line from X to Z as shown in the diagram below. At Y, she was directly under the lamp. The distance between X and Y is the same as the distance between Y and Z.

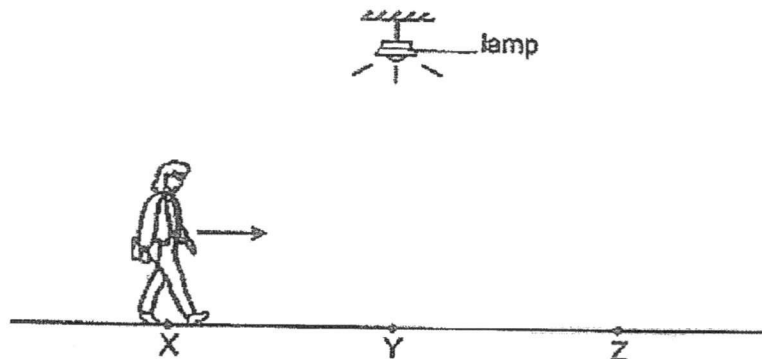

The graph below shows how the length of Mary's shadow on the ground changed during the walk.

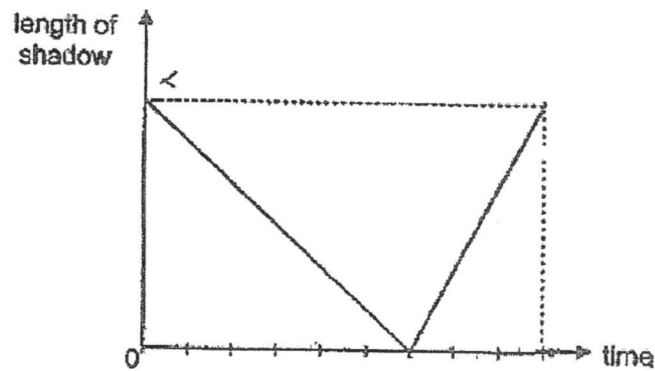

Based on the graph above, which of the following statements about Mary's walk is true?

- (1) She took a longer time to walk from Y to Z than to walk from X to Y.
- (2) She walked at a faster speed between X and Y than between Y and Z.
- (3) She walked at a slower speed between X and Y than between Y and Z.
- (4) As she walked towards the lamp from X to Y, her shadow became longer.

12. Meimei had two similar rods made of materials A and B. She wrapped a piece of white paper tightly round the middle of each rod and heated each piece of paper gently with a candle flame for a few minutes as shown in the diagram below.

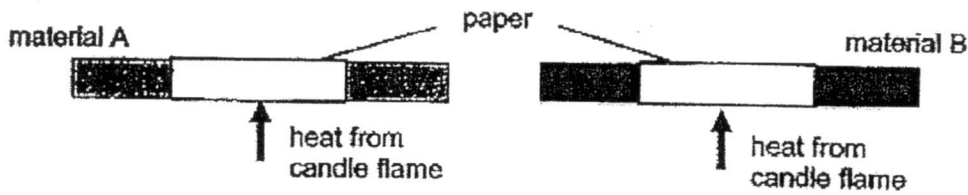

She removed the rods from the flame and examined the two pieces of paper. She recorded her observations in the table below.

Paper wrapped around	Appearance of paper
material A	remained white (unburnt)
material B	turned brown (slightly burnt)

Which of the following correctly explains Meimei's observations?

Which material is a better conductor of heat?	Explanation of observations
(1) A	Material A conducted heat away from the paper more quickly than material B.
(2) B	Material B conducted heat to the paper more quickly than material A.
(3) A	Material A conducted heat to the paper more quickly than material B.
(4) B	Material B conducted heat away from the paper more quickly than material A.

13. The diagram shows electricity cables being put up on a warm day. The cables are hung loosely between the poles, as shown in the diagram.

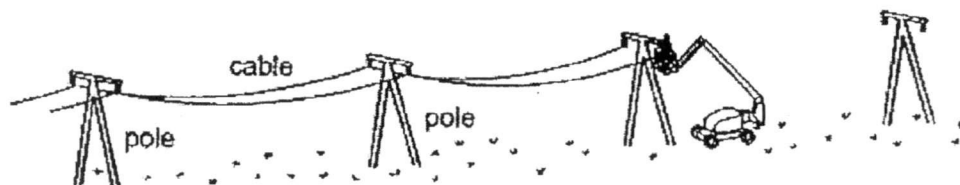

The cables are hung loosely to prevent the cables from breaking due to \_\_\_\_\_.

- (1) expansion of the cables on a hot day
- (2) contraction of the cables on a hot day
- (3) expansion of the cables on a cold day
- (4) contraction of the cables on a cold day

14. The diagram below shows a flowering plant.

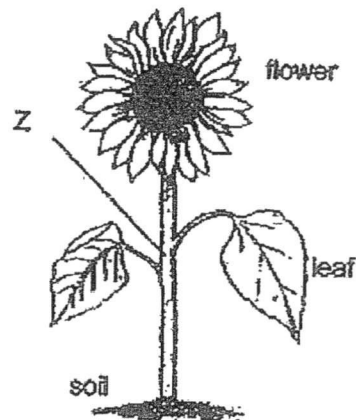

What is the direction in which water and food are being transported at Z?

Direction of transport of	
water	food
(1) upwards only	downwards only
(2) upwards only	both upwards and downwards
(3) downwards only	upwards only
(4) downwards only	both upwards and downwards

15. In which of the following parts of a plant are water-carrying tubes present?

- A : roots
- B : stem
- C : leaves
- D : flowers

- (1) B only
- (2) B and C only
- (3) A, B, and C only
- (4) A, B, C and D

16. Three test-tubes were set up as shown in the diagram and left in full sunlight.

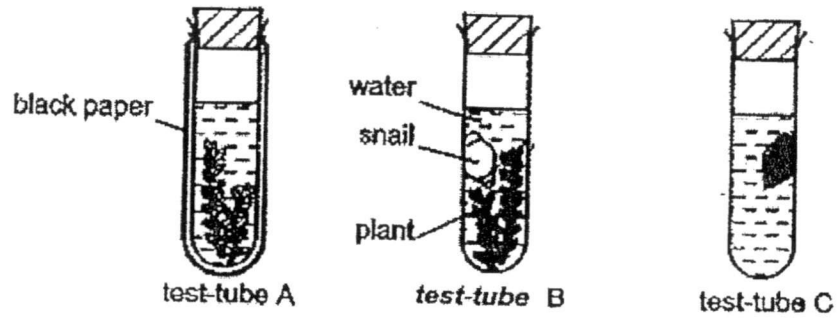

Which of the following correctly describes the change in the amount of carbon dioxide in the water after two hours?

	Test-tube A	Test-tube B	Test-tube C
(1)	decrease	increase	increase
(2)	increase	not possible to tell	increase
(3)	not possible to tell	increase	increase
(4)	increase	decrease	decrease

17. Study the flowchart given below.

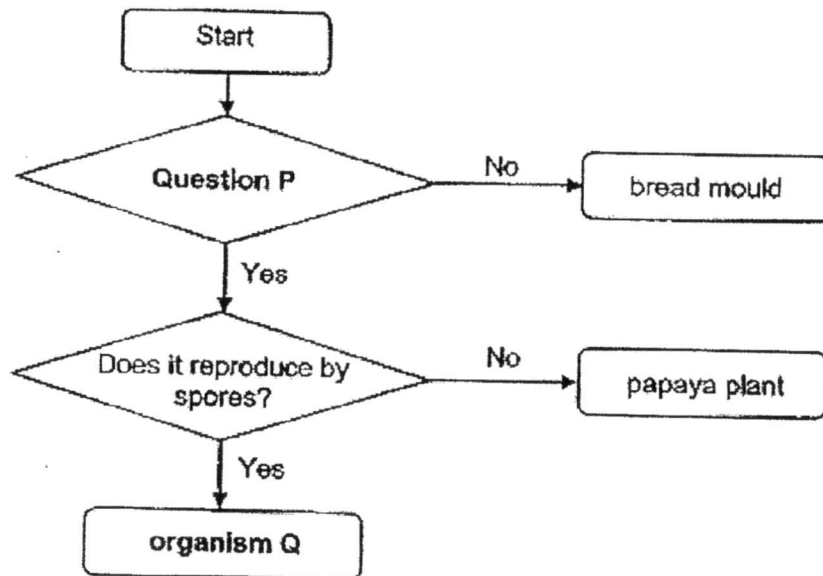

Which of the following is correct?

	Question P	Organism Q
(1)	Does it make its own food?	moss
(2)	Does it produce seeds?	moss
(3)	Does it make its own food?	mushroom
(4)	Does it produce seeds?	mushroom

18. Meena wanted to find out if the temperature of the surroundings affects the amount of water taken in by a plant. The diagram below shows one of her set-ups.

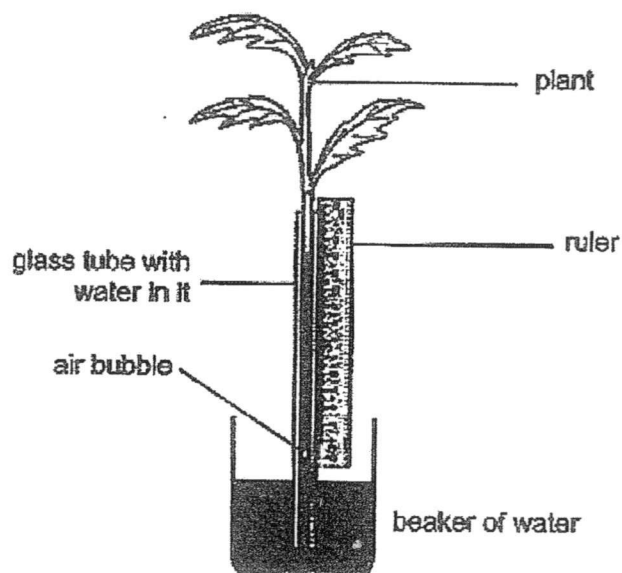

She placed the set-up in a room. She measured the temperature in the room and the distance moved by the air bubble at the end of the experiment. She repeated her experiment in the same room with another similar set-up.

Which of the following variables should be kept constant for a fair test?

- A : Temperature in the room X
- B : Duration of the experiment
- C : Number of leaves on the plant
- D : Position of the air bubble at the end of the experiment X

- (1) A and D
- (2) B and C
- (3) B, C and D
- (4) A, B, C and D

19. The diagram below shows how blood flows in certain parts of the body.

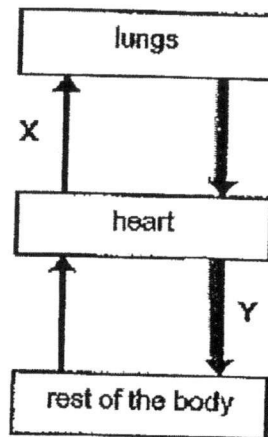

Which of the following about the blood at X and Y is correct?

	X	Y
(1)	high in carbon dioxide	high in oxygen
(2)	high in carbon dioxide	low in oxygen
(3)	low in carbon dioxide	high in oxygen
(4)	low in carbon dioxide	low in oxygen

20. The graph below shows the changes in Jeya's heart rate. He exercised and then stopped after some time.

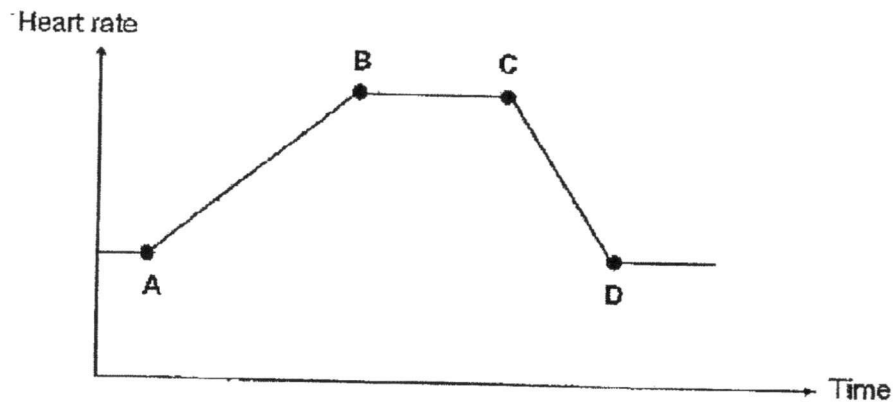

At which points, A, B, C or D, did Jeya start and stop exercising?

	Start exercising	Stop exercising
(1)	A	C
(2)	A	D
(3)	B	C
(4)	B	D

21. The diagram below shows how different types of cells are classified according to certain characteristics, A, B, W, X, Y and Z.

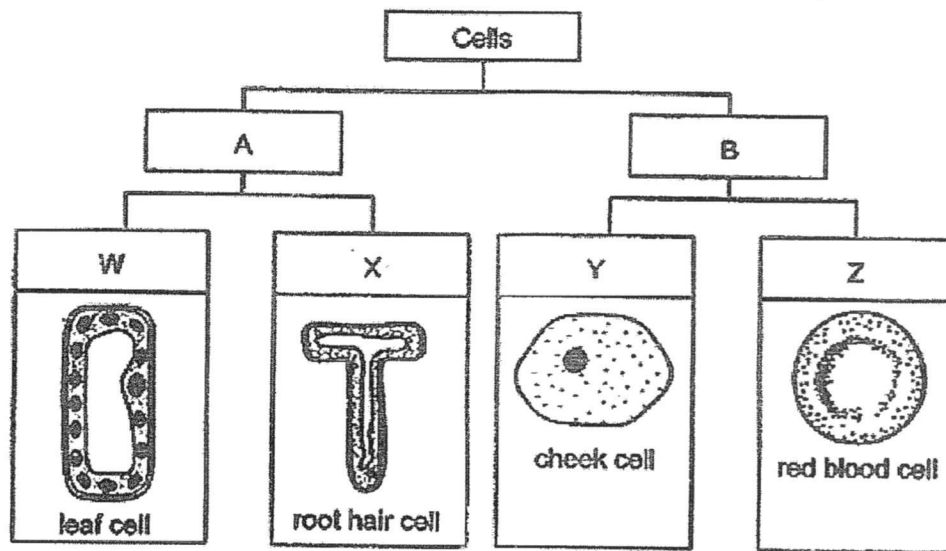

Which of the following is correct?

	W	B
(1)	Has cell wall	Does not have chloroplasts
(2)	Has chloroplasts	Has cell membrane
(3)	Has cell wall	Has cell membrane
(4)	Has chloroplasts	Does not have cell wall

22. The diagram below shows a plant cell.

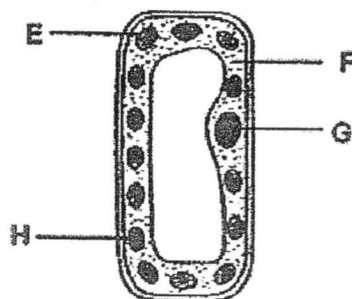

Which part of the cell is not likely to be found in a yeast cell?

- (1) E  
 (2) F  
 (3) G  
 (4) H

23. The diagram below shows two flowers of the same plant.

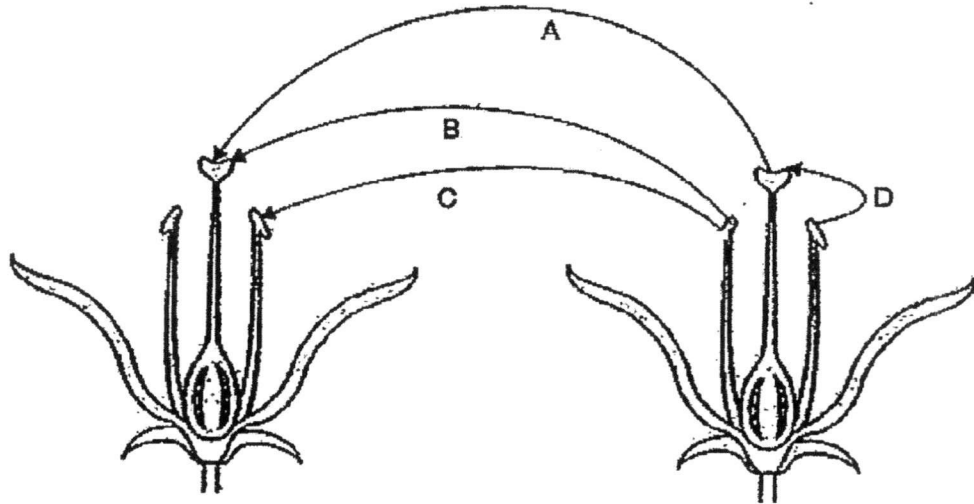

Which of the above arrows represent(s) the process of pollination?

- (1) A only
- (2) B only
- (3) B and D only
- (4) A, B and C

24. Lily counted the number of wild plants X and Y in an area near a river. After three months, she counted the number of plants growing in the same area again. Her observations are shown below.

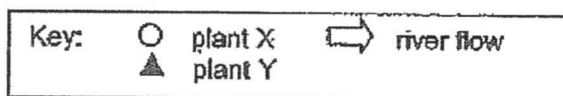
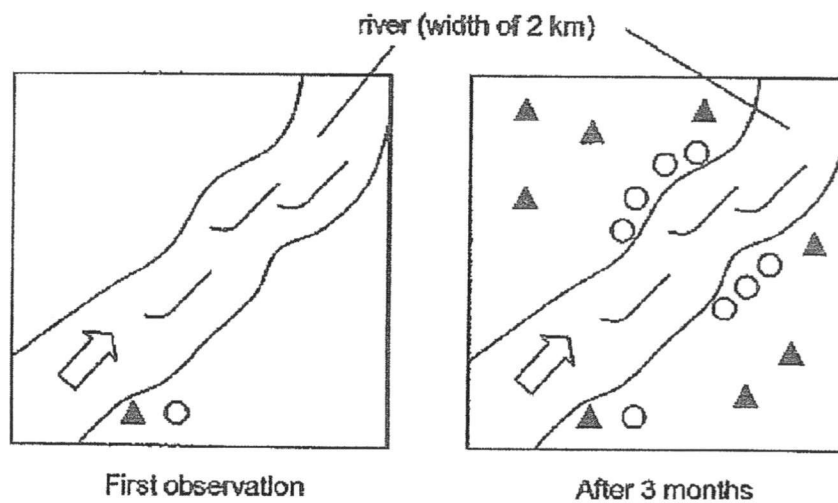

Which of the following correctly describes how the seeds/fruits of plants X and Y were dispersed?

	Plant X	Plant Y
(1)	by wind	by water
(2)	by water	by splitting of fruits
(3)	by wind	by splitting of fruits
(4)	by water	by animals

25. Study the circuit below. The batteries and bulbs are all working properly.

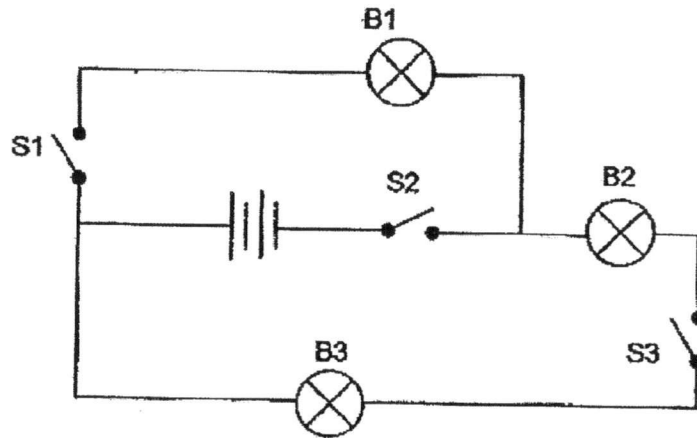

Which of the following observations is possible?

(1)

Switch			Bulb		
S1	S2	S3	B1	B2	B3
off	on	on	lit up	did not light up	did not light up

(2)

Switch			Bulb		
S1	S2	S3	B1	B2	B3
on	off	on	lit up	lit up	lit up

(3)

Switch			Bulb		
S1	S2	S3	B1	B2	B3
on	on	off	lit up	did not light up	did not light up

(4)

Switch			Bulb		
S1	S2	S3	B1	B2	B3
on	on	off	lit up	lit up	did not light up

26. In the circuits below, all the bulbs and batteries used are identical.

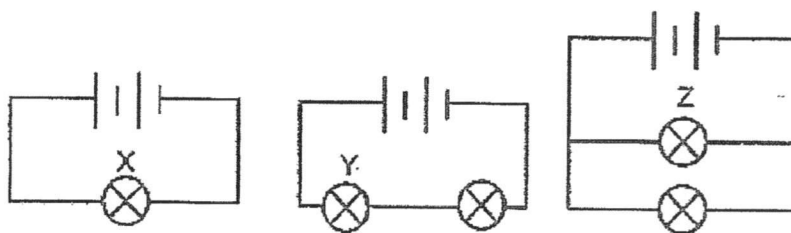

Which of the following conclusions about the three circuits is correct?

- (1) Bulb Z is the dimmest.
- (2) Bulb X is as bright as bulb Z.
- (3) Bulb X is brighter than bulb Z.
- (4) Bulb Y is brighter than bulb X.

27. In the circuit below, all the six bulbs are lit.

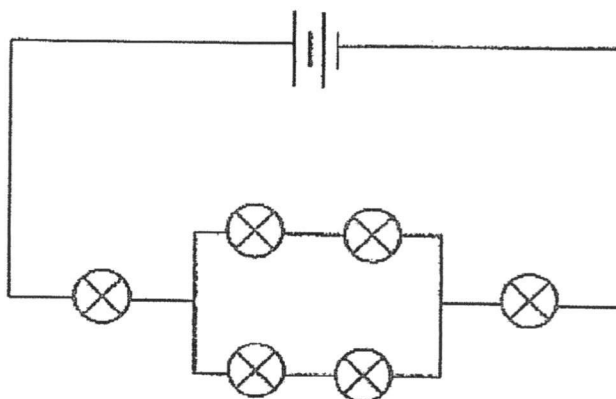

What is the largest number of bulbs that will remain lit when one of the bulbs is fused?

- (1) 0
- (2) 2
- (3) 4
- (4) 5

28. Colin had four materials K, L, M and N. He connected all the materials in a circuit and recorded his observations as shown in the diagrams below.

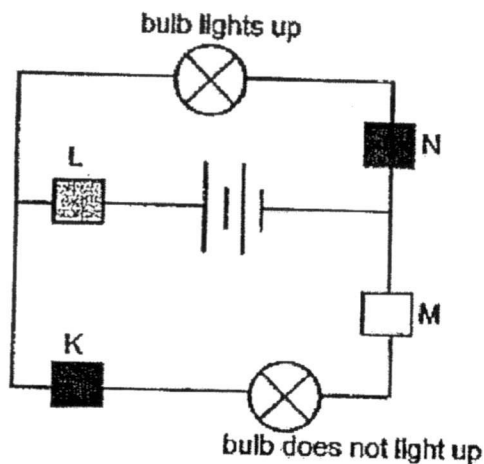

Next, Colin re-arranged the materials in the same circuit and recorded his observations as shown in the diagram below.

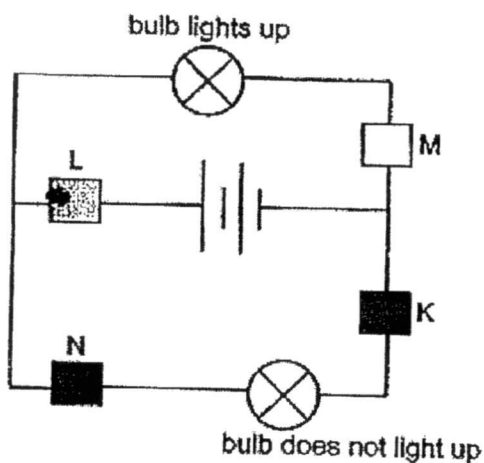

Based on Colin's observation, which of the following correctly classified the materials?

	Electrical Conductor(s)	Electrical Insulator(s)
(1)	L	K, M and N
(2)	K	L, M and N
(3)	L and M	N and K
(4)	L, M and N	K

End of Section A

Pei Chun Public School  
Semestral Assessment 1 – 2017  
Science  
Primary 5

Name : \_\_\_\_\_ (    )

Class : Pri. 5 (    )

Date : 9 May 2017

Time : 1 h 35 min

Science Teacher : \_\_\_\_\_

Parent's signature: \_\_\_\_\_

Section A	56
Section B	34
Practical test	10
Total	100

**Section B (34 marks)**

For questions 29 to 38, write your answers in the spaces provided.

29. Junheng used the set-up below to study a certain property of material.

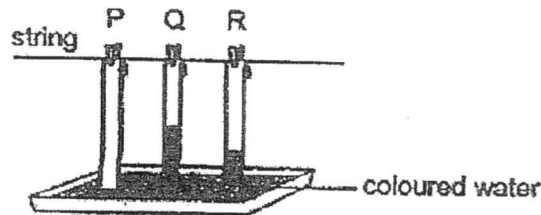

He hung three dry strips of different materials, P, Q and R, on a string and let the ends of each strip touch a tray of coloured water. The strips were of the same length and hung from the same height. After ten minutes, he measured the length of each strip that was stained by the coloured water.. His results are shown below.

Material	Length of material stained by coloured water (cm)
P	0
Q	12
R	5

- a) Name the property of material that is being tested. [ 1 ]

\_\_\_\_\_

- b) Based on his results, which material is the most suitable to be used for making a rain coat? Explain your answer. [ 1 ]

\_\_\_\_\_

\_\_\_\_\_

SCORE	
-------	--

30. Muthu observed that magnet K and object Y were attracted as shown below.

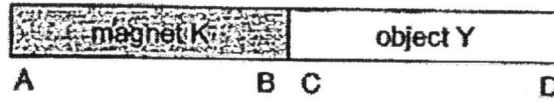

a) Give a reason why Muthu cannot conclude whether object Y is a magnet or not based on the observation. [1]

---

b) Using only magnet K and object Y, what should Muthu do to conclude whether object Y is a magnet? Explain your answer. [2]

---

---

---

SCORE	
-------	--

31. Lenny removed the bottom half of a plastic bottle and placed the top half on the surface of the water as shown in diagram 1. Diagram 2 shows what he observed after he had pushed the bottle into the water.

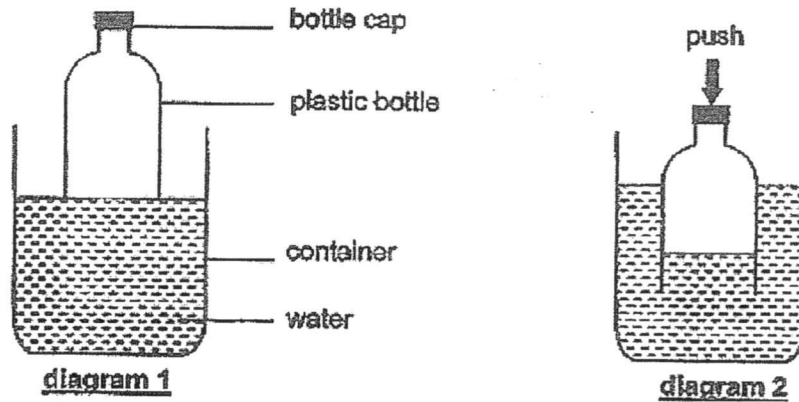

- a) Lenny observed that some water entered the plastic bottle when it was pushed down but the water level in the bottle was lower than the water level in the container. Explain his observations. [ 2 ]

---



---



---

- b) Lenny removed the bottle cap. He observed that the water level in the bottle went up. Explain his observation. [ 1 ]

---



---

- c) Which of the following diagrams correctly shows the water levels in both the container and the bottle after the bottle cap had been removed? Choose your answer by ticking (✓) in the box below the diagram. [ 1 ]

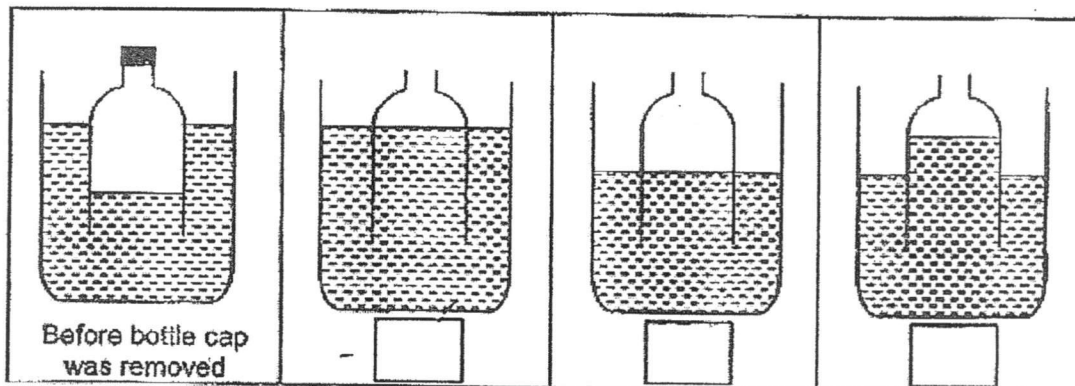

SCORE	
-------	--

32. Xiao Ming set up the experiment shown below. When the torch was switched on, a dark shadow of the wooden block was formed on the wall.

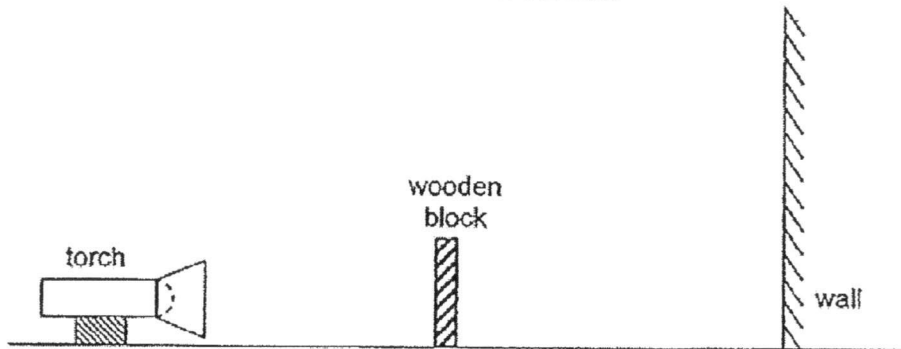

Xiao Ming wanted to find out how variable X would affect the height of the shadow formed on the wall. He changed variable X and measured the height of the shadow formed. He did not move the torch throughout his experiment.

His results are shown below.

Variable X (cm)	Height of shadow formed (cm)
5	18
10	12
15	8

- a) State two properties of light that cause shadows to form. [ 2 ]

Property 1: \_\_\_\_\_  
 \_\_\_\_\_

Property 2: \_\_\_\_\_  
 \_\_\_\_\_

- b) What is variable X? [ 1 ]

\_\_\_\_\_

- c) Give a reason why the same wooden block must be used throughout the experiment to ensure a fair test. [ 1 ]

\_\_\_\_\_  
 \_\_\_\_\_

- d) Xiao Ming replaced the wooden block with a similar block made of frosted glass. He observed that the shadow formed on the wall was lighter. Give a reason for his observation. [ 1 ]

\_\_\_\_\_  
 \_\_\_\_\_

SCORE	
-------	--

33. Aziz learnt that the cell membrane allows certain substances to enter and leave a cell. He conducted an experiment to find out if the cell membrane allows water to pass through. He soaked an animal cell in a dish of water. After a while, the animal cell appeared swollen. The diagram below shows his observation.

original animal cell      cell swelled in size



- a) Based on his observation, what could Aziz conclude about the cell membrane of the animal cell? [ 1 ]

---



---

- b) Aziz also observed that the animal cell in the dish of water burst after some time as shown below.

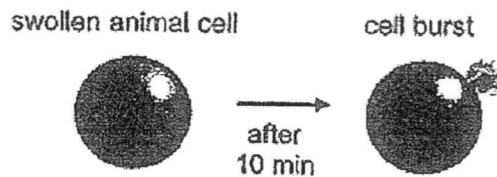

Aziz repeated the experiment with a plant cell. He soaked the plant cell in a dish of water for one hour. He observed that the plant cell appeared swollen but did not burst after one hour.

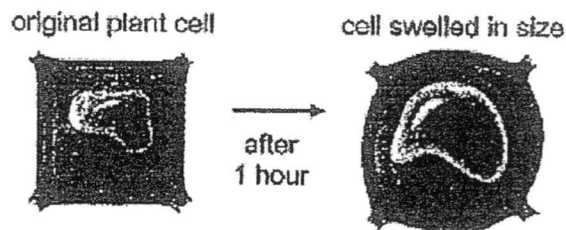

- Which part of the plant cell prevented it from bursting like the animal cell? [ 1 ]

---

34. Veron conducted an experiment using three plastic cups as shown below. In set-up S, two of the plastic cups were placed one inside the other. A rubber ring kept the two cups separated so that the air between the cups was trapped. 200 cm<sup>3</sup> of water was poured into the cups in the two set-ups.

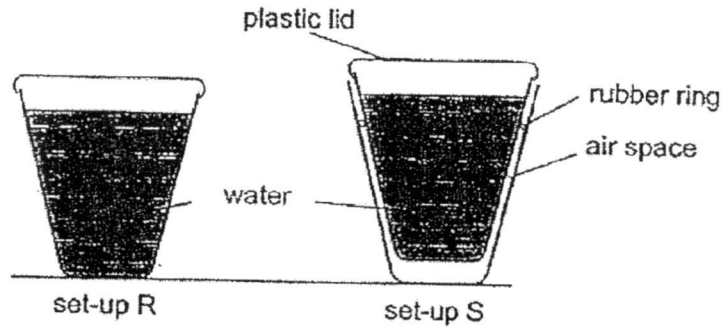

She placed both set-ups on a table. She measured and recorded the temperature of the water in both set-ups at different times. Her results are shown in the graph below.

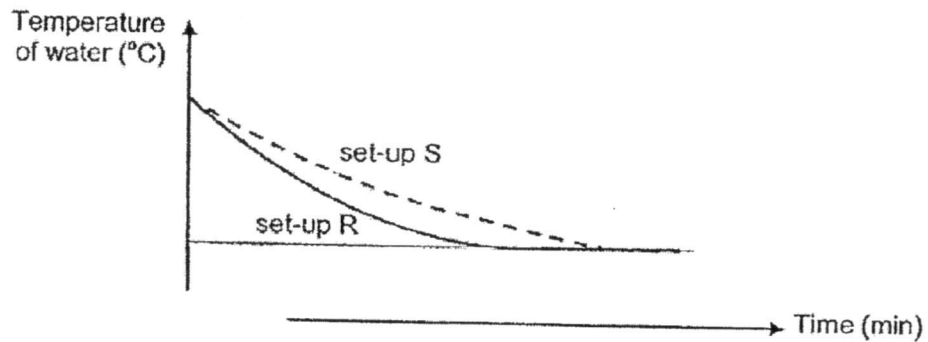

- a) Explain why the temperature of the water in set-up R decreased with time. [ 1 ]

---



---

- b) Based on Veron's results, what could she conclude about the conduction of heat by air? Explain your answer. [ 2 ]

---



---



---

*Continue on the next page*

c) The diagram below shows two building materials, A and B.

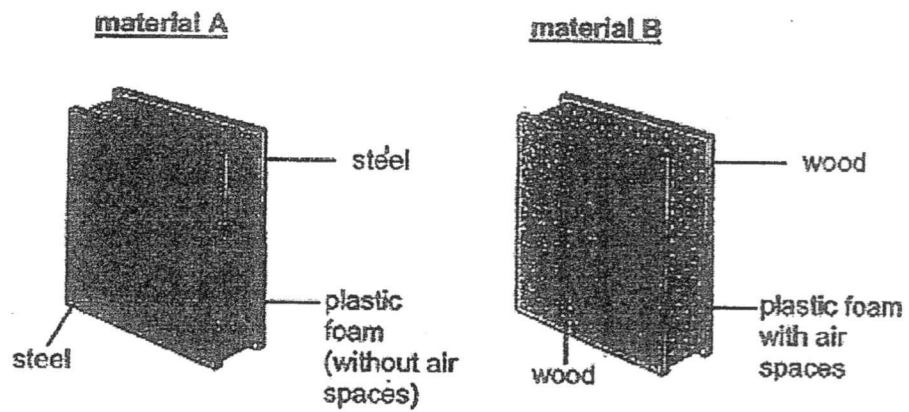

Based on Veron's experiment, explain how walls made of material B would help keep the inside of a house cooler on a hot day, as compared to walls made of material A.

[2]

---

---

---

---

SCORE	
-------	--

35. Yuki set up an experiment using four similar leaves, A, B, C and D, from plant X. These leaves have openings known as stomata on both their upper and lower surfaces. Leaves lose water through the stomata.

She cut the leaves from the plant and coated some surfaces of the leaves with oil that did not drip as shown in the table below.

Leaf	Coated with oil	
	Upper surface	Lower surface
A	no	no
B	yes	yes
C	no	yes
D	yes	no

She weighed each of the leaves and hung them up in an open area. After five hours, each leaf was weighed again and the loss of mass of each leaf was recorded.

- a) Which leaf, A, B, C or D, would have the greatest loss in mass? Explain your answer.

[ 1 ]

- b) Yuki wanted to compare the number of stomata on the upper and lower surfaces of the leaf of plant X. The table below shows the results for leaf C and D.

Leaf	Loss in mass (g)
C	1
D	0.05

Based on her results, what could Yuki conclude about the number of stomata on the upper and lower surfaces of the leaf of plant X?

[ 1 ]

*Continue on the next page*

36. The graph below shows the rate of blood flowing to the muscles in Devi's body when she was at rest and exercising.

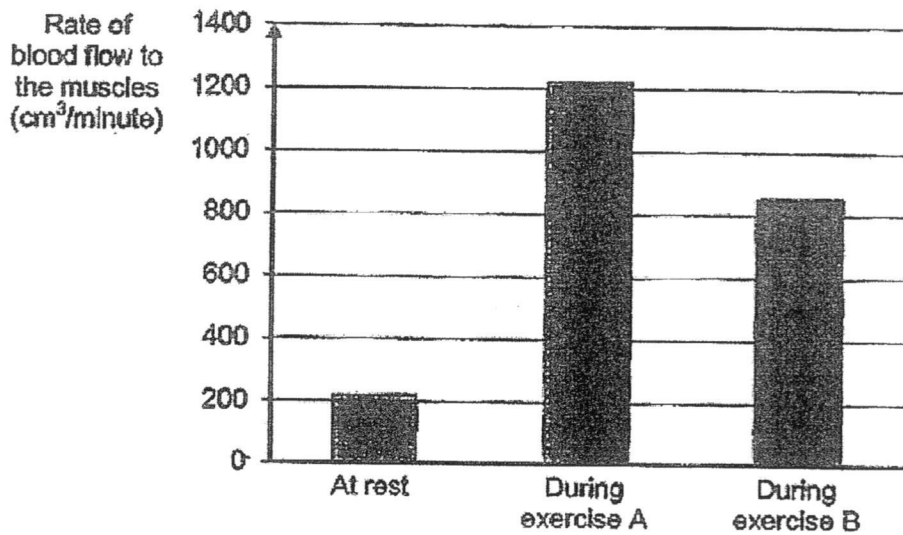

- a) Explain why blood had to flow more quickly to Devi's muscles when she was exercising.

[ 2 ]

---

---

---

---

---

- b) Based on the graph, which type of exercise, A or B, would cause Devi's heart rate to be lower? Explain your answer.

[ 1 ]

---

---

SCORE	
-------	--

- c) Yuki conducted another experiment with two similar pots of plant as shown below. The plants were watered with the same amount of water at the start of the experiment. She only coated the surfaces of all the leaves on plant S with oil that did not drip.

The two identical glass tanks were sealed and left in a well-lit place for three hours.

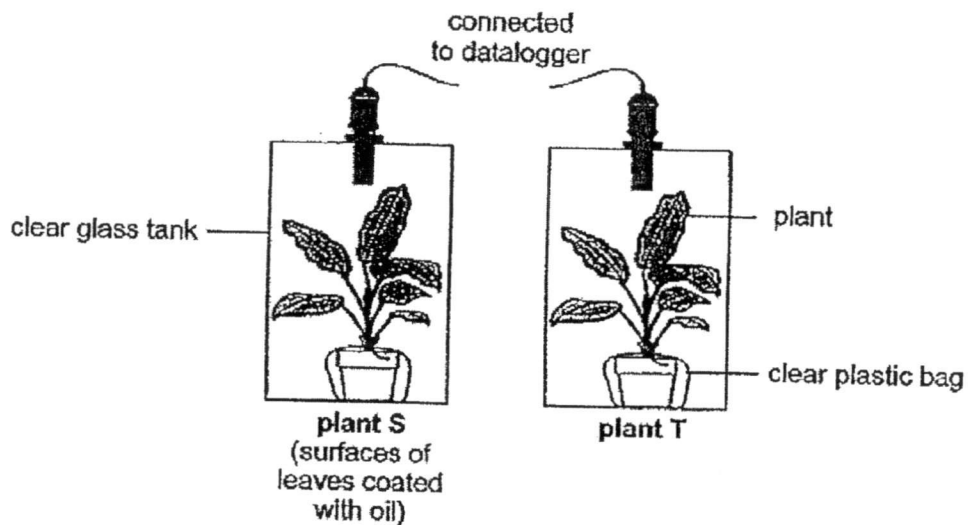

She measured the amount of oxygen in the tanks at the start and at the end of the experiment.

In which tank would there be more oxygen at the end of the experiment?  
Explain your answer.

[ 2 ]

There would be more oxygen in the tank with plant \_\_\_\_\_.

---

---

---

37. Wei Cheng carried out an experiment to find out how the height at which fruit M is dropped affects the distance it travels. The diagram below shows fruit M.

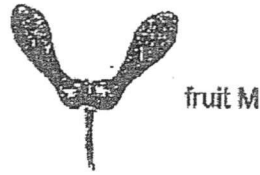

- a) Based on the diagram, suggest the method of dispersal for fruit M. Give a reason for your answer.

[ 1 ]

---



---

He dropped fruit M from a height ( $H$ ) in front of a fan as shown. He measured the distance ( $D$ ) travelled by the fruit.

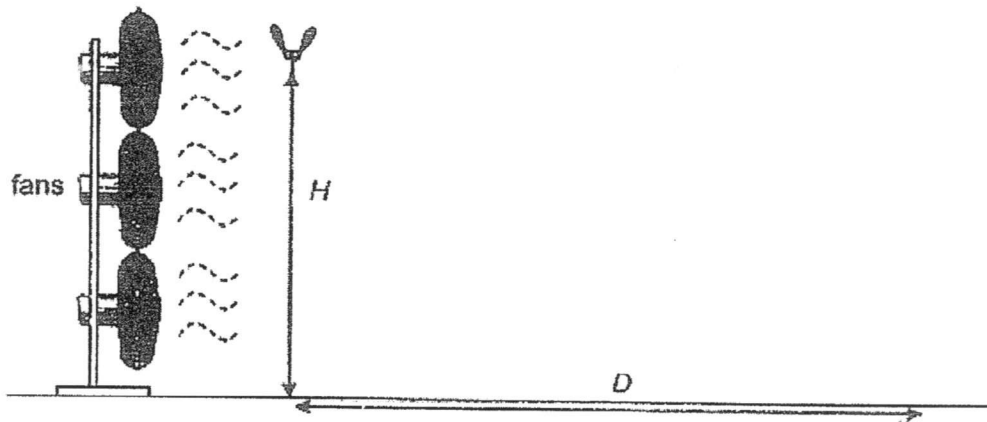

He repeated his experiment by dropping fruit M from different heights. The table below shows the results of his experiment.

$H$ (cm)	140	120	100	80
$D$ (cm)	60	50	44	35

- b) State how the distance ( $D$ ) travelled by the fruit changes with the height ( $H$ ) at which it was dropped.

[ 1 ]

---



---

- c) Based on the results, why is it an advantage for fruit M to be found growing on a tall parent plant?

[ 1 ]

---



---

SCORE	
-------	--

38. Rajoo constructed a circuit for a doorbell as shown in diagram 1. X is an iron bar inside a coil of insulated wire. A short while after he had closed the switch, steel rod Y moved up and the hammer hit the bell as shown in diagram 2.

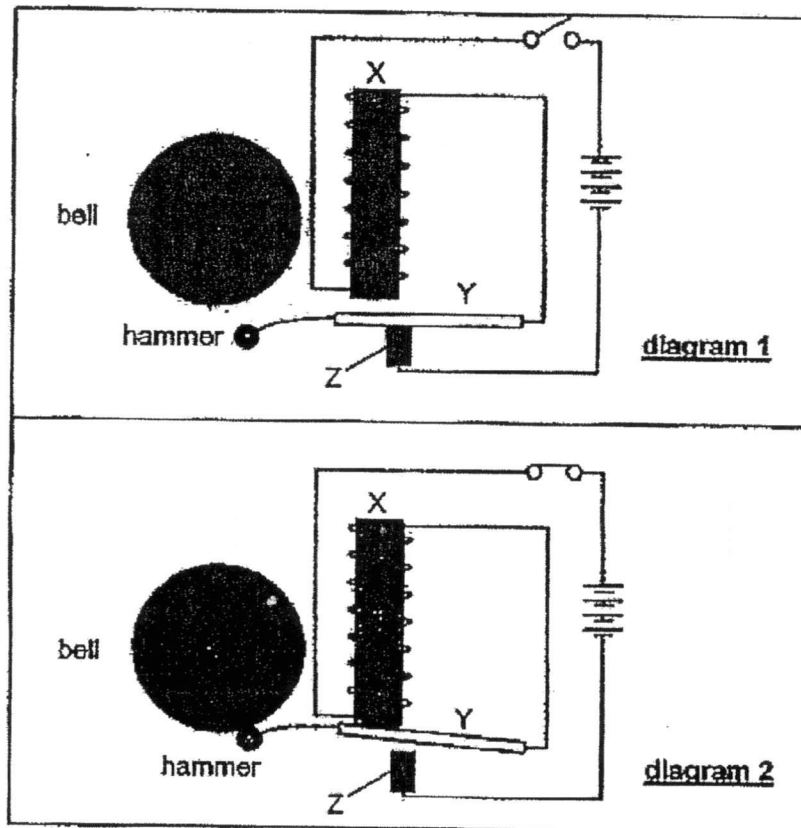

- a) Explain why the hammer hit the bell after Rajoo closed the switch. [ 1 ]

---



---

- b) After the hammer has hit the bell, Rajoo observed that rod Y moved down and touched bar Z again. Explain why rod Y moved down. [ 1 ]

---



---

- c) Rajoo replaced steel rod Y with a similar rod made of aluminium. Would the hammer still hit the bell after he had closed the switch? Give a reason for your answer. [ 1 ]

---



---

End of Section B

Set by : Mr Benjamin Kua, Mdm Samantha Gooi & Miss Parvin Kaur  
 Vetted by: P5 Science teachers

SCORE	
-------	--

# ANSWER SHEET

EXAM PAPER 2017 (P5)

SCHOOL : PEI CHUN

SUBJECT : SCIENCE

TERM : SA1

Q1	Q2	Q3	Q4	Q5	Q6	Q7	Q8	Q9	Q10
2	3	3	4	3	2	4	3	3	2
Q11	Q12	Q13	Q14	Q15	Q16	Q17	Q18	Q19	Q20
3	1	4	2	4	2	1	2	1	1
Q21	Q22	Q23	Q24	Q25	Q26	Q27	Q28		
4	1	3	4	3	2	3	4		

Name: \_\_\_\_\_ Class: \_\_\_\_\_

P5 Semestral Assessment 1 (2017) - Corrections

29. **Concept:**

- A waterproof material does NOT absorb water.

a) Adsorbency of water / Ability to absorb water

*Compare the materials*

b) P. only material P is water proof.

30. **Concept:**

- A magnet attracts magnetic material.
- Like poles of magnets repel each other.

a) Even though magnet K attracted object Y, object Y could be a magnetic object.

b) Action: Place end B of magnet K next to end D of object Y.  
Conclusion: If they repel each other, object Y is a magnet.

31. **Concept:**

- Air occupies space.
- Air can be compressed

a) **Observation 1:**  
There was air occupying the space in the bottle.

**Observation 2:**  
The air in the bottle was compressed.

b) The air in the bottle could escape through the mouth of the bottle.

32.

a) Properties of light:

1: Light travels in a straight line.

2: A shadow is formed when light is blocked.

b) Only the position of the ~~torch~~<sup>block</sup> could be changed.  
When variable X increases, the height of the shadow decreases.  
(When the block is further away from the torch, the shadow will be shorter.)

Distance between the wooden block and the torch.

c) Other than the tested variable, we keep other variables the same so that they would not affect the results of an experiment. Do not give a general statement.

The size (variable) of the wooden block will affect the height of the shadow (results)

d) Compare the properties of frosted glass and wood.

Frosted glass allows some light to pass through but wood does not allow light to pass through.

33. When asked for a conclusion, you must refer to the aim of the experiment.

a) Aim: "to find out if the cell membrane allows water to pass through."

Cell membrane (allows / does not allow ) water to pass through it .

b) Which part of the cell gives it a regular shape?

cell wall

34. Concepts:

- a)
- When an object loses heat, its temperature decreases.
  - When an object gains heat, its temperature increases.

The water in set-up R  
( gained heat from // lost heat to ) the surroundings.

- b) Refer to the graph, the temperature of the water in set-up S took a longer time to fall to room temperature and that tells us that the trapped air between the cups caused the water to lose heat slower.

Air is a poor conductor heat.

The water in set-up S lost heat slower than the water in set-up R.

- c) Compare material A and B (steel and wood, air spaces?)  
In part (b), we learnt that trapped air is a poor conductor of heat.

The wall will gain heat from the air outside the house and the sun. The heat will pass through the wall and the air inside of the house will gain heat from the wall.

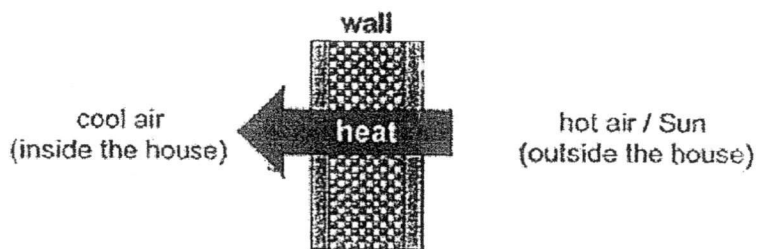

Discuss how the trapped air in the air spaces and wood are going to affect the heat transfer.

Wood is a poorer conductor of heat than steel.

The trapped air and wood would (reduce / increase )

heat (gain / loss ) from the hot air outside of the house / Sun.

35 Concept:

- a) • Leaves lose water through the stomata.  
• Stomata allow exchange of gases in plants.  
• Oil blocks the stomata on the leaves and prevents the exchange of gases.

Compare the leaves.

Leaf A. None of the stomata leaf A was blocked by oil. Thus, the leaf lost the most water.

- b) Leaf C lost more water than leaf D. It has ( more / fewer ) stomata blocked by oil. Its lower surface was covered in oil.

There are fewer stomata on the lower surface of the leaf.

- c) Concepts:
- Oil on the leaf prevented air from entering and leaving through the stomata.
  - Plants take in carbon dioxide for photosynthesis and produce oxygen.

Compare plants S and T

(The leaves on plant S were coated in oil which prevented air from entering and leaving through the stomata so) Plant S could not take in carbon dioxide and carry out photosynthesis.

However, plant T could take in carbon dioxide. It could carry out photosynthesis and produce oxygen. Thus, there would be more oxygen in the tank with plant T.

36 Concepts:

- a)
- The human body uses oxygen and digested food to produce energy.
  - Oxygen and digested food are transported around the body in the blood.

Answer the question directly. Do NOT just write down what you have memorised.

~~"When we exercise, we need more energy. Our heart pumps faster to transport more digested food and oxygen in the blood to all parts of our body to produce more energy."~~

When Devi was exercising, she needed more energy.

The blood in her body had to flow more quickly to transport more digested food and oxygen to her muscles to produce more energy.

- b) Lower heart rate → blood flows ( faster / slower )

Exercise B. Her blood was flowing slower during the exercise and the exercise required less energy.

37

a) Fruit M has wing-like structure so it is dispersed by wind.

b) As the height at which the seed was dropped decreased, the distance travelled by it decreased.

c) Concept:

- Plants disperse their seeds to prevent overcrowding so as to reduce competition for sunlight, water and minerals between the young plants and the parent plants.

Refer to the results of the experiment:

tall parent plant → seed would be dropped higher from the ground and seed would travel further away from the parent plant.

The seeds would be dispersed further away from the parent plant and there would be less competition for sunlight, water and minerals among the plants.

38

a) When the circuit was closed, bar X became an electromagnet and attracted rod Y.

b) When rod Y moved up to touch bar X, the circuit was open. Bar X was no longer an electromagnet and could not attract rod Y.

c) No. Aluminium is a non-magnetic material so bar X could not attract the aluminium rod for the hammer to hit the bell.