

Visit

FreeTestPaper.com

for more papers



ZHONGHUA SECONDARY SCHOOL MID YEAR EXAMINATION 2016

Name of Pupil : _____ ()
Class : 1E ____
Subject / Code : MATHEMATICS / 4048
Level : Sec 1 Express
Date : 10 May 2016
Duration : 2 hours

INSTRUCTIONS TO CANDIDATES

Write your name, index number and class on all the work you hand in.

Write in dark blue or black pen with non-erasable ink.

You may use a pencil for any diagrams or graphs.

Do **not** use correction fluid or correction tape.

Answer **ALL** questions.

If working is needed for any question it must be shown with the answer.

Omission of essential working will result in loss of marks.

Calculators should be used where appropriate.

If the degree of accuracy is not specified in the question, and if the answer is not exact, give the answer to **three significant figures**.

For π , use either your calculator value or 3.142, unless the question requires the answer in terms of π .

Section A:

If working is needed for any question it must be shown in the space below that question.

Section B:

Answer **all** questions on the writing paper provided.

At the end of the examination, fasten all your work securely together.

Hand in Section A and Section B separately.

Error in	Marks Deducted
Presentation	
Accuracy	
Missing/Wrong Units	

Section	Marks
A	50
B	30
Total	80

The marks for each question or part of a question are shown in the brackets [].

This paper consists of **14** printed pages including this cover page.

Section A (50 marks)

1. (a) Round off 0.0749618 to 3 significant figures.

Answer (a) [1]

- (b) Use a calculator to evaluate $\frac{\sqrt{42} - \left(\frac{11}{3}\right)^2}{0.7\pi + \left(\sqrt[3]{151} - (-2)^3\right)}$, giving your answer correct to 2 decimal places.

Answer (b) [1]

2. Without the use of a calculator, **estimate** the value of $\frac{17 \div \sqrt{93}}{\sqrt[3]{209} - 4.58}$, giving your answer correct to 1 significant figure.

Answer [2]

3. Study the set of numbers and write down all the **irrational numbers** in the answer space provided.

$$-0.33, -\frac{1}{7}, 0, \sqrt{169}, \pi, \sqrt{0.5}, \sqrt{8}, 1.\dot{3}, 2^3$$

Answer [1]

4. Written as the product of its prime factors,

$$252 = 2^2 \times 3^2 \times 7.$$

(a) Express 630 as the product of its prime factors in index notation.

Answer (a) _____ [1]

(b) Find the HCF of 252 and 630. Give your answer as the product of its prime factors in index notation.

Answer (b) _____ [1]

(c) Find the smallest possible value of a whole number x if $630x$ is a multiple of 252.

Answer (c) _____ [2]

5. Simplify the following expressions.

(a) $3(x - y) + [5x - (-2x + y)]$

Answer (a) _____ [3]

(b) $\frac{(x - 2x^2)}{x} - 4x$

Answer (b) _____ x [2]

6. Factorise the following expressions completely

(a) $42ac - 7c$,

Answer (a) _____ [1]

(b) $5x^2 - 10xy + 15x$.

Answer (b) _____ [1]

7. Solve the following equations.

(a) $5k + 4 = -2(k - 9)$

Answer (a) [2]

(b) $7 - n = \frac{-9n + 1}{2}$

Answer (b) _____ [3]

8. If $k = \sqrt{\frac{2m}{m-n}}$, find the value of n when $k = 2$ and $m = -4$.

Answer _____ [3]

9. George has \$ y and Sam has \$18 more than George. Tim has half the total amount of George and Sam.

Find an expression, in terms of y , for

- (a) the amount of money Sam has,

Answer (a) [1]

- (b) the total amount the 3 of them have together.

Answer (b) [2]

10. Without using a calculator and showing your working clearly, evaluate

$$\left(\frac{2}{3} + \frac{3}{4}\right) \times \left(\frac{4}{3} \div \frac{2}{3}\right).$$

Answer [3]

11. The foot of the mountain is at sea level. The temperatures at the foot and at the summit of the mountain are 11°C and -7°C respectively.

(a) Find the difference between the two temperatures.

Answer (a) [1]

(b) Suppose that the temperature drops by 6°C for every 1000 m above sea level. How high is the mountain above sea level?

Answer (b) [2]

12.

WAFFLES

Write down all the letters in the word above that have

- (a) one line of symmetry,

Answer (a) [1]

- (b) rotational symmetry of order two.

Answer (b) [1]

13. In the figure below, OA , OB , OC and OD are all straight lines. $\angle COB = 90^\circ$ and $\angle AOB = 80^\circ$.

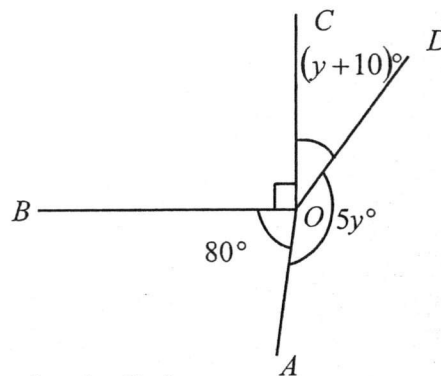

Stating your reasons clearly, find

- (a) the value of y ,

Answer (a) [2]

- (b) the obtuse angle AOD .

Answer (b) [1]

14. In the figure below, ABC , DEF and BHF are straight lines. $AC \parallel DF$ and $BD \parallel CE$.
 $\angle DBF = 67^\circ$ and $\angle BDF = 50^\circ$.

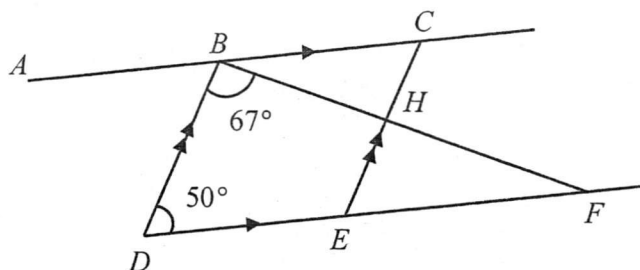

Stating your reasons clearly, find

- (a) $\angle BCE$,

Answer (a) [1]

- (b) $\angle ABD$,

Answer (b) [1]

- (c) $\angle CBH$.

Answer (c) [2]

15. In the diagram below, $ABCD$ is a quadrilateral. $\angle DAB = 112^\circ$ while two of its exterior angles are 65° and 121° . Find the value of x .

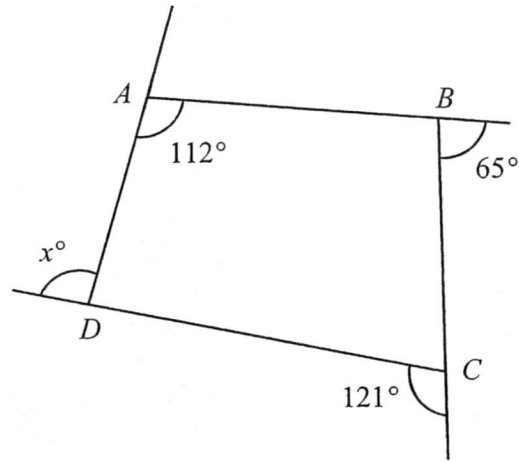

Answer _ [2]

16. (a) In the answer space below, construct a triangle XYZ such that $XY = 9$ cm, $YZ = 10$ cm and $\angle XYZ = 85^\circ$. The line XY has already been drawn. [3]
- (b) On the same diagram,
- (i) construct the angle bisector of $\angle XZY$. [1]
- (ii) construct the perpendicular bisector of YZ . [1]
- (c) The point M is the intersection of the two bisectors drawn. Measure and write down the value of obtuse $\angle XMZ$.

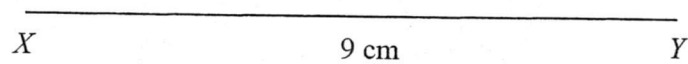

Answer (c) [1]

Section B (30 marks)

Answer **all** the questions in this section on the writing paper provided.

- 1 (a) A rectangular board measures 198 cm by 156 cm. It is cut into squares of equal size with no material left over.
- Find
- (i) the largest possible length of the side of the square, [2]
 - (ii) the largest possible area of such a square. [1]
 - (iii) the number of squares formed. [1]
- (b) Two different comets pass through our solar system every 64 years and 216 years respectively. The last time they passed through our solar system together was in the year 2014. In which year will they next pass through our solar system together? [3]
-

- 2 Raymond bought a total of 18 Mathematics and Science textbooks during a sale. He bought y Mathematics textbooks.
- (a) Express the number of Science textbooks he bought in terms of y . [1]
- The cost of a Mathematics textbook was \$6 and the cost of a Science textbook was \$10.
- (b) Write down and simplify an expression, in terms of y , for the total amount Raymond spent. [2]
- (c) Given that the total amount Raymond spent was \$136, form an equation in y and solve it to find the number of Mathematics textbooks he bought. [2]
-

- 3 A salesman monthly wage, $\$W$, is based on the formula
- $$W = B + 20C,$$
- where B is the basic wage and C is the number of watches he sold in a month.
- (a) Given that the salesman received \$1250 for selling 28 watches in a particular month, find B . [2]
 - (b) What does the number 20 in the formula represent? [1]
 - (c) If the salesman sold 45 watches in a month, find his monthly wage. [1]
-

4 (a) Express $\frac{4x+3}{2} - \frac{x-4}{5} + x$ as a single fraction in its simplest form. [3]

(b) Solve the equation $\frac{2}{3y-5} = \frac{3}{7-2y}$. [3]

- 5 In the diagram below, $ABCDE$ forms part of a regular n -sided polygon. Two **equilateral** triangles, $\triangle BCP$ and $\triangle CDR$, and a **square** $CPQR$ are constructed along the side BCD of the polygon.

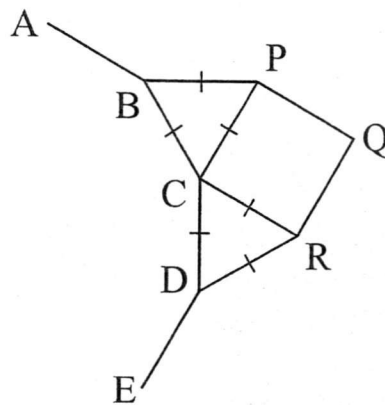

Find the number of sides, n , of the n -sided polygon. [3]

- 6 Lisa has been tasked to create an eco-garden in her school with organic top soil. The diagram below shows the plan of the eco-garden whereby each square is 2 m by 2 m.

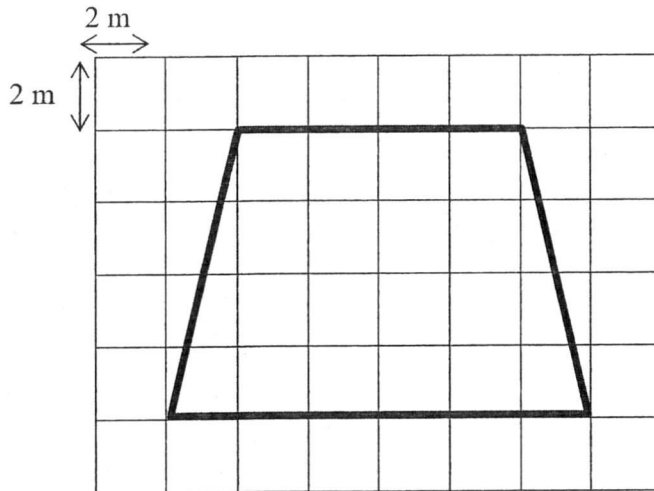

- (a) Find the area of the eco-garden shown in the plan above.

[2]

Lisa was tasked to buy organic top soil to fill the eco-garden in her school. She saw this advertisement in the newspaper.

Value Packs	No. of kilograms per pack	Cost per kilogram
A	1 or 2	5.98
B	3 or 4	5.59
C	5 or 6	5.22

- (b) To fill the eco-garden completely, Lisa needs 8 kg of organic top soil. Which **two** value packs should she buy such that it is **more cost-effective** for the school? Explain your recommendation with relevant working.

[3]

End of Paper

Check all your answers carefully!



ZHONGHUA SECONDARY SCHOOL MID YEAR EXAMINATION 2016

Name of Pupil : _____ ()
Class : 1E ____
Subject / Code : MATHEMATICS / 4048
Level : Sec 1 Express
Date : 10 May 2016
Duration : 2 hours

INSTRUCTIONS TO CANDIDATES

Write your name, index number and class on all the work you hand in.

Write in dark blue or black pen with non-erasable ink.

You may use a pencil for any diagrams or graphs.

Do **not** use correction fluid or correction tape.

Answer **ALL** questions.

If working is needed for any question it must be shown with the answer.

Omission of essential working will result in loss of marks.

Calculators should be used where appropriate.

If the degree of accuracy is not specified in the question, and if the answer is not exact, give the answer to **three significant figures**.

For π , use either your calculator value or 3.142, unless the question requires the answer in terms of π .

Section A:

If working is needed for any question it must be shown in the space below that question.

Section B:

Answer **all** questions on the writing paper provided.

At the end of the examination, fasten all your work securely together.

Hand in Section A and Section B separately.

Error in	Marks Deducted
Presentation	
Accuracy	
Missing/Wrong Units	

Section	Marks
A	50
B	30
Total	80

The marks for each question or part of a question are shown in the brackets [].

This paper consists of **14** printed pages including this cover page.

Section A (50 marks)

1. (a) Round off 0.0749618 to 3 significant figures.

Answer (a) 0.0750 [B1] [1]

- (b) Use a calculator to evaluate $\frac{\sqrt{42} - \left(\frac{11}{3}\right)^2}{0.7\pi + \left(\sqrt[3]{151} - (-2)^3\right)}$, giving your answer correct to 2 decimal places.

$$\begin{aligned} \frac{\sqrt{42} - \left(\frac{11}{3}\right)^2}{0.7\pi + \left(\sqrt[3]{151} - (-2)^3\right)} &= -0.448571181 \\ &= -0.45 \text{ (correct to 2 dec. pl.)} \end{aligned}$$

Answer (b) -0.45 [B1] [1]

2. Without the use of a calculator, **estimate** the value of $\frac{17 \div \sqrt{93}}{\sqrt[3]{209} - 4.58}$, giving your answer correct to 1 significant figure.

$$\begin{aligned} &\frac{17 \div \sqrt{93}}{\sqrt[3]{209} - 4.58} \\ &\approx \frac{20 \div \sqrt{100}}{\sqrt[3]{216} - 5} \quad \text{---- [M1] 4 correct estimation} \\ &= \frac{20 \div 10}{6 - 5} \\ &= 2 \quad \text{---- [A1]} \end{aligned}$$

Answer 2 [2]

3. Study the set of numbers and write down all the **irrational numbers** in the answer space provided.

$$-0.33, -\frac{1}{7}, 0, \sqrt{169}, \pi, \sqrt{0.5}, \sqrt{8}, 1.\dot{3}, 2^3$$

Answer $\pi, \sqrt{0.5}, \sqrt{8}$ [B1] [1]

4. Written as the product of its prime factors,

$$252 = 2^2 \times 3^2 \times 7.$$

- (a) Express 630 as the product of its prime factors in index notation.

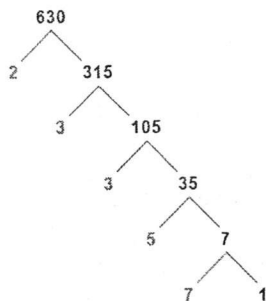

$$630 = 2 \times 3^2 \times 5 \times 7 \quad \text{---- [B1]}$$

Answer (a) $630 = 2 \times 3^2 \times 5 \times 7$ [1]

- (b) Find the HCF of 252 and 630. Give your answer as the product of its prime factors in index notation.

$$252 = 2^2 \times 3^2 \times 7$$

$$630 = 2 \times 3^2 \times 5 \times 7$$

$$\text{HCF} = 2 \times 3^2 \times 7 \quad \text{---- [B1]}$$

Answer (b) $2 \times 3^2 \times 7$ [1]

- (c) Find the smallest possible value of a whole number x if $630x$ is a multiple of 252.

$$\text{L.C.M} = 2^2 \times 3^2 \times 5 \times 7 \quad \text{---- [M1]}$$

$$630x = 2 \times 3^2 \times 5 \times 7$$

$$x = \frac{2^2 \times 3^2 \times 5 \times 7}{2 \times 3^2 \times 5 \times 7}$$

$$x = 2 \quad \text{---- [A1]}$$

Answer (c) $x = 2$ [2]

5. Simplify the following expressions.

(a) $3(x - y) + [5x - (-2x + y)]$

$$\begin{aligned} & 3(x - y) + [5x - (-2x + y)] && \text{---- [M1] Expansion of “} -(-2x + y)\text{”} \\ & = 3(x - y) + (5x + 2x - y) \\ & = 3(x - y) + (7x - y) \\ & = 3x - 3y + 7x - y && \text{---- [M1] Expansion of “} 3(x - y)\text{”} \\ & = 10x - 4y && \text{---- [A1]} \end{aligned}$$

Answer (a) $10x - 4y$ [3]

(b) $\frac{(x - 2x^2)}{x} - 4x$

$$\begin{aligned} & \frac{(x - 2x^2)}{x} - 4x \\ & = \frac{x(1 - 2x)}{x(1)} - 4x && \text{---- [M1] “} 1 - 2x\text{” seen} \\ & = 1 - 2x - 4x \\ & = 1 - 6x && \text{---- [A1]} \end{aligned}$$

Answer (b) $1 - 6x$ [2]

6. Factorise the following expressions completely

(a) $42ac - 7c,$

$$42ac - 7c = 7c(6a - 1) \quad \text{---- [B1]}$$

$$\text{Answer (a) } \underline{7c(6a - 1)} \quad [1]$$

(b) $5x^2 - 10xy + 15x.$

$$5x^2 - 10xy + 15x = 5x(x - 2y + 3) \quad \text{---- [B1]}$$

$$\text{Answer (b) } \underline{5x(x - 2y + 3)} \quad [1]$$

7. Solve the following equations.

(a) $5k + 4 = -2(k - 9)$

$$5k + 4 = -2(k - 9)$$

$$5k + 4 = -2k + 18$$

---- [M1] Expansion of “ $-2(k - 9)$ ”

$$5k + 2k = 18 - 4$$

$$7k = 14$$

$$k = 2$$

---- [A1]

$$\text{Answer (a) } \underline{k = 2} \quad [2]$$

(b) $7 - n = \frac{-9n + 1}{2}$

$$7 - n = \frac{-9n + 1}{2}$$

$$2(7 - n) = -9n + 1$$

---- [M1] Multiply both sides by 2

$$14 - 2n = -9n + 1$$

---- [M1] Expansion of “ $2(7 - n)$ ”

$$-2n + 9n = 1 - 14$$

$$7n = -13$$

$$n = -1\frac{6}{7}$$

---- [A1]

$$\text{Answer (b) } n = \underline{-1\frac{6}{7}} \quad [3]$$

8. If $k = \sqrt{\frac{2m}{m-n}}$, find the value of n when $k = 2$ and $m = -4$.

$$k = \sqrt{\frac{2m}{m-n}}$$

$$2 = \sqrt{\frac{2(-4)}{-4-n}} \quad \text{---- [M1] Substitution of correct values}$$

$$2^2 = \frac{-8}{-4-n} \quad \text{---- [M1] Square both sides}$$

$$4(-4-n) = -8$$

$$-16 - 4n = -8$$

$$-4n = -8 + 16$$

$$-4n = 8$$

$$n = -2 \quad \text{---- [A1]}$$

Answer $n = -2$ [3]

9. George has $\$y$ and Sam has $\$18$ more than George. Tim has half the total amount of George and Sam.

Find an expression, in terms of y , for

- (a) the amount of money Sam has,

$$\text{Sam has } \$(y + 18) \quad \text{---- [B1]}$$

Answer (a) $\$(y + 18)$ [1]

- (b) the total amount the 3 of them have together.

Amount of money Tim has

$$= \frac{1}{2}(y + y + 18)$$

$$= \$(y + 9) \quad \text{---- [M1]}$$

Total amount

$$= y + (y + 18) + (y + 9)$$

$$= \$(3y + 27) \quad \text{---- [A1]}$$

Answer (b) $\$(3y + 27)$ [2]

10. Without using a calculator and showing your working clearly, evaluate

$$\left(\frac{2}{3} + \frac{3}{4}\right) \times \left(\frac{4}{3} \div \frac{2}{3}\right)$$

$$\left(\frac{2}{3} + \frac{3}{4}\right) \times \left(\frac{4}{3} \div \frac{2}{3}\right)$$

$$= \left(\frac{8}{12} + \frac{9}{12}\right) \times \left(\frac{4}{3} \times \frac{3}{2}\right) \quad \text{---- [M1] fractions with common denominator}$$

---- [M1] change \div to \times and take reciprocal of the fraction

$$= \frac{17}{12} \times 2$$

$$= \frac{17}{6}$$

$$= 2\frac{5}{6}$$

---- [A1]

Answer $2\frac{5}{6}$ [3]

11. The foot of the mountain is at sea level. The temperatures at the foot and at the summit of the mountain are 11°C and -7°C respectively.

- (a) Find the difference between the two temperatures.

Difference between the two temperatures

$$= 11 - (-7)$$

$$= 18^{\circ}\text{C}$$

---- [B1]

Answer (a) 18°C [1]

- (b) Suppose that the temperature drops by 6°C for every 1000 m above sea level. How high is the mountain above sea level?

Height of the mountain

$$= \frac{18}{6} \times 1000 \quad \text{---- [M1]}$$

$$= 3000 \text{ m} \quad \text{---- [A1]}$$

OR No. of times = $18 \div 6$

$$= 3$$

$$\text{Height of mountain} = 3 \times 1000 \quad \text{---- [M1]}$$

$$= 3000 \text{ m} \quad \text{---- [A1]}$$

Answer (b) 3000 m [2]

12.

WAFFLES

Write down all the letters in the word above that have

(a) one line of symmetry,

Answer (a) W, A, E [B1] [1]

(b) rotational symmetry of order two.

Answer (b) S [B1] [1]

13. In the figure below, OA , OB , OC and OD are all straight lines. $\angle COB = 90^\circ$ and $\angle AOB = 80^\circ$.

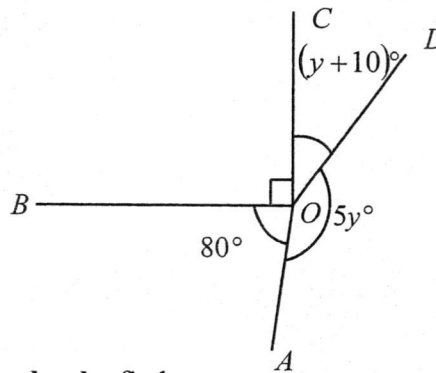

Stating your reasons clearly, find

(a) the value of y ,

$$90 + 80 + 5y + y + 10 = 360 \quad (\angle\text{s at a point}) \quad \text{---- [M1] } \textcircled{O}, \text{P for missing/wrong}$$

$$180 + 6y = 360$$

$$y = 30$$

reason

---- [A1]

Answer (a) $y = 30$ [2]

(b) the obtuse angle AOD .

$$\angle AOD = 5(30)$$

$$= 150^\circ$$

---- [B1]

Answer (b) 150° [1]

14. In the figure below, ABC , DEF and BHF are straight lines. $AC \parallel DF$ and $BD \parallel CE$.
 $\angle DBF = 67^\circ$ and $\angle BDF = 50^\circ$.

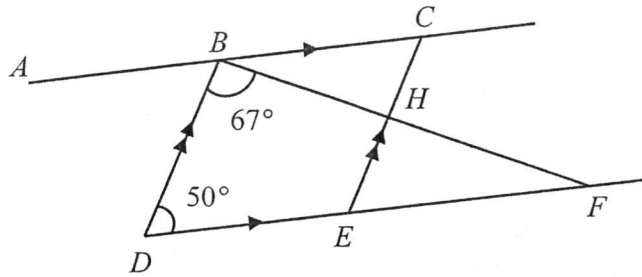

Stating your reasons clearly, find

- (a) $\angle BCE$,
 $\angle BCE$
 $= 50^\circ$ (opp. \angle s of //gram) ---- [B1] , P for missing/wrong reason

Answer (a) 50° [1]

- (b) $\angle ABD$,
 $\angle ABD$
 $= 50^\circ$ (alt. \angle s, $AC \parallel DF$) ---- [B1] , P for missing/wrong reason

Or

$\angle ABD$
 $= 50^\circ$ (corr. \angle s, $BD \parallel CE$)

Answer (b) 50° [1]

- (c) $\angle CBH$.
 $\angle CBH$
 $= 180^\circ - 50^\circ - 67^\circ$ (adj. \angle s on a st. line) ---- [M1] , P for missing/wrong reason
 $= 63^\circ$ or (int. \angle s, $BC \parallel DE$) ---- [A1]

Answer (c) 63° [2]

15. In the diagram below, $ABCD$ is a quadrilateral. $\angle DAB = 112^\circ$ while two of its exterior angles are 65° and 121° . Find the value of x .

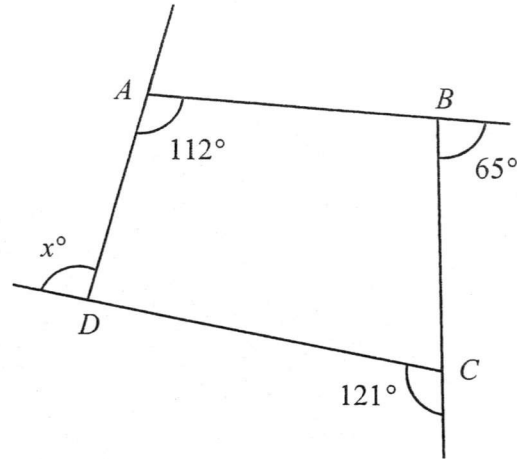

$$\begin{aligned}
 x + (180 - 112) + 65 + 121 &= 360 \quad (\text{ext. } \angle \text{ sum of polygon}) \quad \text{----} \quad \text{[M1]} \quad \text{O,P for} \\
 x + 68 + 65 + 121 &= 360 \quad \text{missing/wrong} \\
 x &= 360 - 284 \quad \text{reason} \\
 x &= 106 \quad \text{----} \quad \text{[A1]}
 \end{aligned}$$

OR

$$\begin{aligned}
 \angle ABC &= 180^\circ - 65^\circ \quad (\text{adj. } \angle \text{s on a str. line}) \\
 &= 115^\circ \\
 \angle BCD &= 180^\circ - 121^\circ \quad (\text{adj. } \angle \text{s on a str. line}) \\
 &= 59^\circ \\
 \angle ADC &= 360^\circ - 115^\circ - 59^\circ - 112^\circ \quad (\angle \text{ sum of quadrilateral}) \\
 &= 74^\circ \\
 \angle x &= 180^\circ - 74^\circ \quad (\text{adj. } \angle \text{s on a str. line}) \quad \text{----} \quad \text{[M1]} \quad \text{O,P for missing/wrong} \\
 &= 106^\circ \quad \text{reason} \\
 & \quad \quad \quad \text{[A1]}
 \end{aligned}$$

Answer $x = 106^\circ$ [2]

16. (a) In the answer space below, construct a triangle XYZ such that $XY = 9$ cm, $YZ = 10$ cm and $\angle XYZ = 85^\circ$. The line XY has already been drawn. [3]
- (b) On the same diagram,
- (i) construct the angle bisector of $\angle XZY$. [1]
- (ii) construct the perpendicular bisector of YZ . [1]
- (c) The point M is the intersection of the two bisectors drawn. Measure and write down the value of obtuse $\angle XMZ$.

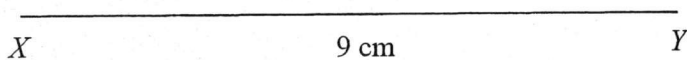

[C3] - correct shape
 - YZ arc seen
 - $\angle XYZ$ measured

Answer (c) $\angle XMZ = \underline{144^\circ}$ [1]

Section B (30 marks)

Answer **all** the questions in this section on the writing paper provided.

- 1 (a) A rectangular board measures 198 cm by 156 cm. It is cut into squares of equal size with no material left over.
- Find
- (i) the largest possible length of the side of the square, [2]
 - (ii) the largest possible area of such a square. [1]
 - (iii) the number of squares formed. [1]
- (b) Two different comets pass through our solar system every 64 years and 216 years respectively. The last time they passed through our solar system together was in the year 2014. In which year will they next pass through our solar system together? [3]
-

- 2 Raymond bought a total of 18 Mathematics and Science textbooks during a sale. He bought y Mathematics textbooks.
- (a) Express the number of Science textbooks he bought in terms of y . [1]
- The cost of a Mathematics textbook was \$6 and the cost of a Science textbook was \$10.
- (b) Write down and simplify an expression, in terms of y , for the total amount Raymond spent. [2]
- (c) Given that the total amount Raymond spent was \$136, form an equation in y and solve it to find the number of Mathematics textbooks he bought. [2]
-

- 3 A salesman monthly wage, $\$W$, is based on the formula
- $$W = B + 20C,$$
- where B is the basic wage and C is the number of watches he sold in a month.
- (a) Given that the salesman received \$1250 for selling 28 watches in a particular month, find B . [2]
 - (b) What does the number 20 in the formula represent? [1]
 - (c) If the salesman sold 45 watches in a month, find his monthly wage. [1]
-

4 (a) Express $\frac{4x+3}{2} - \frac{x-4}{5} + x$ as a single fraction in its simplest form. [3]

(b) Solve the equation $\frac{2}{3y-5} = \frac{3}{7-2y}$. [3]

- 5 In the diagram below, $ABCDE$ forms part of a regular n -sided polygon. Two **equilateral** triangles, $\triangle BCP$ and $\triangle CDR$, and a **square** $CPQR$ are constructed along the side BCD of the polygon.

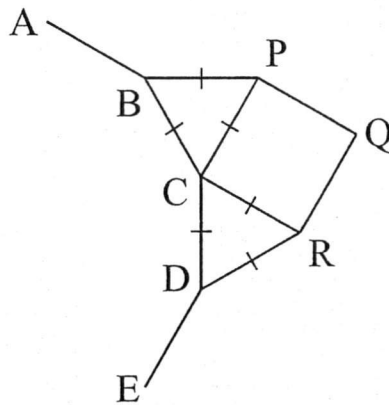

Find the number of sides, n , of the n -sided polygon. [3]

- 6 Lisa has been tasked to create an eco-garden in her school with organic top soil. The diagram below shows the plan of the eco-garden whereby each square is 2 m by 2 m.

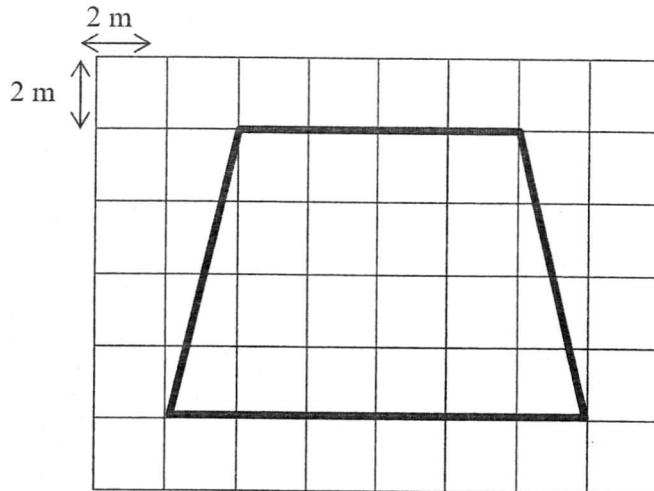

- (a) Find the area of the eco-garden shown in the plan above.

[2]

Lisa was tasked to buy organic top soil to fill the eco-garden in her school. She saw this advertisement in the newspaper.

Value Packs	No. of kilograms per pack	Cost per kilogram
A	1 or 2	5.98
B	3 or 4	5.59
C	5 or 6	5.22

- (b) To fill the eco-garden completely, Lisa needs 8 kg of organic top soil. Which **two** value packs should she buy such that it is **more cost-effective** for the school? Explain your recommendation with relevant working.

[3]

End of Paper

Check all your answers carefully!

ZHONGHUA SECONDARY SCHOOL
 MID-YEAR EXAMINATIONS (SEC 1E)
 ANSWER KEY

Section A		Section B	
1a	0.0750	1ai	6 cm
b	-0.45	aii	36 cm ²
2	2	aiii	858
3	$\pi, \sqrt{0.5}, \sqrt{8}$	b	3742
4a	$630 = 2 \times 3^2 \times 5 \times 7$	2a	$(18 - y)$
b	$2 \times 3^2 \times 7$	b	$\$(-4y + 180)$
c	$x = 2$	c	11
5a	$10x - 4y$	3a	\$690
b	$1 - 6x$	b	The number 20 represent the commission/extra money he will receive with every watch sold.
6a	$7c(6a - 1)$	c	\$1590
b	$5x(x - 2y + 3)$	4a	$\frac{28x + 23}{10}$
7a	$k = 2$	b	$y = 2\frac{3}{13}$
b	$-1\frac{6}{7}$	5	12
8	$n = -2$	6a	80 m ²
9a	$\$(y + 18)$	b	Lisa needs to buy 5 kg of Value Pack C organic soil and 3 kg of Value Pack B organic soil to make up of 8 kg of organic top soil. The lowest cost that she can get is \$42.87.
b	$\$(3y + 27)$		
10	$2\frac{5}{6}$		
11a	18°C		
b	3000 m		
12a	W, A, E		
b	S		
13a	$y = 30$		
b	150°		
14a	50°		
b	50°		
c	63°		
15	$x = 106^\circ$		
16c	144°		