

Visit

FreeTestPaper.com

for more papers

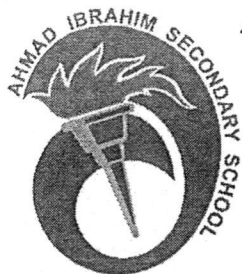

AHMAD IBRAHIM SECONDARY SCHOOL

END OF YEAR EXAMINATION 2016

MATHEMATICS PAPER (100 Marks)

Level: Secondary 1 Express

DATE: 5th Oct 2016

DURATION: 2 hours 30 minutes

NAME: _____

CLASS: _____

INDEX NO: _____

ADDITIONAL MATERIALS:

Nil

READ THESE INSTRUCTIONS FIRST

Write your answers and working on all the separate writing papers provided.

Write your name, class and index number on all the work you hand in.

Write in dark blue or black pen.

You may use a pencil for any diagrams or graphs.

Do not use staples, paper clips, highlighters, glue or correction fluid.

Answer **all** questions in **Section A and Section B**.

If working is required for any question, it must be shown with the answer in the given space.

Omission of essential working will result in loss of marks.

Write your answers in the spaces provided on the question paper.

Calculators should be used where appropriate.

If the degree of accuracy is not specified in the question, and if the answer is not exact, give the answer to three significant figures. Give answer in degrees to one decimal place.

For π , use either your calculator value or 3.142, unless the question requires the answer in terms of π .

The number of marks is given in brackets [] at the end of each question or part question.

The total marks for this paper is 100.

This question paper consists of 19 printed pages including the cover page.

SECTION A (50 Marks)

1. Consider the ten numbers: 1, 5, 8, 19, 47, 51, 111, 216, 999, 1000.

Write down

- (a) the composite numbers,
(b) the perfect cubes.

Ans: (a) _____ [2]

(b) _____ [2]

2. Find the value of $\sqrt[3]{13824}$ by using prime factorisation.

Ans: _____ [3]

3. If p and q are whole numbers such that $p \times q = 37$, find the value of $p + q$ and explain your answer.

Ans: $p + q =$ _____ [1]

Explain: _____ [2]

4. (a) Determine whether the statement "If 2 and 4 are factors of a number, then 8 is also a factor of that number" is true or false.
(b) If it is true, explain your reasoning. If it is false, give a counterexample.

Ans: (a) The above statement is _____ [1]

(b) _____ [1]

5. Consider the eight numbers: $(-0.5)^2$, 0 , $\sqrt[3]{-9}$, $\frac{18}{5}$, $\sqrt{100}$, $(-4)^3$, 17 , $-\frac{24}{3}$.

Write down

- (a) the positive numbers,
(b) the integers.

Ans: (a) _____ [2]

(b) _____ [2]

6. (a) Showing your working, express $100 \times 0.\dot{5}\dot{7}$ as a repeating decimal.
- (b) Hence, find the value of $100 \times 0.\dot{5}\dot{7} - 0.\dot{5}\dot{7}$.

Ans: (a) _____ [2]

(b) _____ [2]

7. Factorise the algebraic expression $4a - 8(b - 2c)$ completely.

Ans: _____ [2]

8. (a) If $z = -3^x - y^3$, find the value of z when $x = 2$ and $y = -3$.
- (b) Simplify $(-2a) \times (-3b) + 5ba - 7a + 4b \times (-a) - a$.

Ans: (a) $z =$ _____ [2]

(b) _____ [2]

9. Solve the equation $\frac{2x+1}{x-3} = 2\frac{1}{3}$.

Ans: $x = \underline{\hspace{2cm}}$ [3]

10. Explain clearly in the space provided why $x = 40$ in the figure below. Show your working and reasoning clearly.

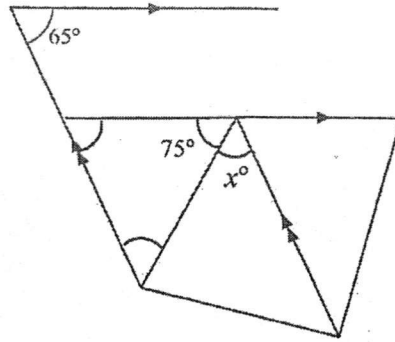

[3]

11. If the sum of the interior angles of a decagon (10-sided) is greater than the sum of the interior angles of another regular polygon by 540° , find the number of sides of the polygon.

Ans: No. of sides = _____ [3]

12. An object moves 7.2 km in 1 hour. Find its speed in

- (a) metres per minute,
- (b) centimetres per second.

Ans: (a) _____ m/min [2]

(b) _____ cm/s [2]

13. (a) Solve the inequality $8x - 11x > -9$.

(b) Illustrate the above solutions on a number line.

(b)  [1]

Ans: (a) _____ [2]

14. The diagram shows two semicircles with the same centre O . Measurements are in metres.

Find, in terms of π ,

- (a) the perimeter of the shaded region,
- (b) the area of the shaded region.

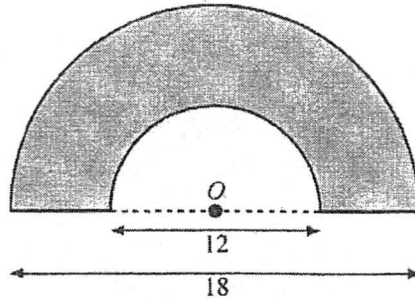

Ans: (a) _____ m [2]

(b) _____ m^2 [2]

15. Tasnim earns \$85 on selling 80 tins of biscuits. If Tasnim bought 100 tins of biscuits for \$425, calculate
- (a) the cost of one tin of biscuits that Tasnim paid,
 - (b) the profits of one tin of biscuits as a percentage of its cost.

Ans: (a) \$ _____ [1]
(b) _____ % [3]

SECTION B (50 Marks)

1. Ms Lim has 200 g of red plasticine, 380 g of grey plasticine and 420 g of yellow plasticine. She divided the plasticine into small balls of equal mass for her Art lesson.

Find

- (a) the largest possible mass of one small ball of plasticine,
(b) the number of plasticine balls she obtained for each colour.

Ans: (a) _____ g [3]

(b) _____ red balls [1]

_____ grey balls [1]

_____ yellow balls [1]

2. (a) Construct $\triangle ABC$ such that $AB = 5.5$ cm, $BC = 10$ cm and $AC = 5.5$ cm. [2]
- (b) Construct the perpendicular bisector of AC . [1]
- (c) Construct the angle bisector of $\angle CAB$. [1]

- (d) Qi Yun, Erni, Kwan Pin and Zeti share a sum of money. Qi Yun takes $\frac{1}{5}$ of the sum of money. After Qi Yun has taken her share, Erni takes $\frac{1}{3}$ of the remaining money. After Erni has taken her share, Kwan Pin takes $\frac{1}{4}$ of the remaining money. After Kwan Pin has taken her share, Zeti takes all of the remaining money. What fraction of the sum of money is Zeti's share?

Ans: (d) _____ [4]

3. (a) The marks scored by a class of 20 students in a Mathematics test are as follows:

49	46	69	61	49
50	45	62	57	69
68	60	49	59	57
68	45	55	46	50

Copy and complete the frequency table below.

[2]

Marks (x)	Tally	Frequency
$45 \leq x < 50$		
$50 \leq x < 55$		
$55 \leq x < 60$		
$60 \leq x < 65$		
$65 \leq x < 70$		

- (b) Mei Xuan conducted a survey among a group of students who travel to school either by bus or by car. She displayed the data collected with a pictogram shown below.

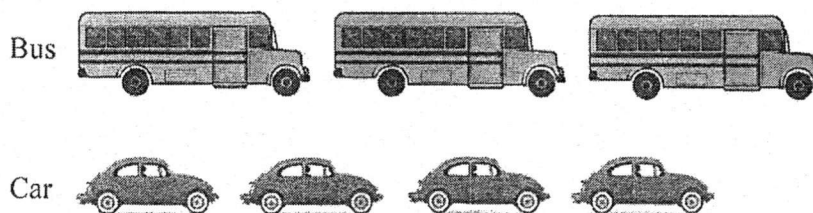

What is a possible misinterpretation of the above data and how would you modify the above pictogram to avoid misinterpretation?

Ans: _____

[2]

4. Mave drove for a distance of 135 km at a speed of x km/h and Charmaine drove for a distance of 120 km at a speed 10 km/h slower than Mave. Given that the **time taken** by the both of them are the **same**, find the speed each of them drove at.

Ans: **Mave:** _____ km/h

Charmaine: _____ km/h [5]

5. The diagram below shows the first three of a sequence of dot patterns.

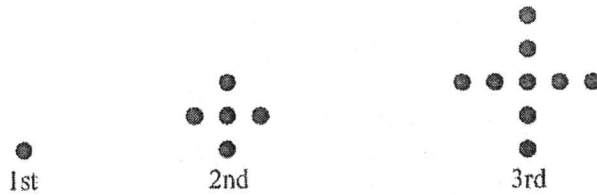

- (a) The information from the sequence of dots is tabulated below.
Complete the table. [1]

Pattern	Formula	Number of dots
1	1	1
2	$4 + 1$	5
3	$4 + 4 + 1$	9
4		

- (b) Write down a formula, T_n to calculate the number of dots in the n th pattern.
 (c) Hence, find the number of dots in the 25th pattern.
 (d) Find the value of m if there are 501 dots in the m th pattern.

Ans: (b) $T_n = \underline{\hspace{2cm}}$ [2]

(c) $\underline{\hspace{2cm}}$ dots [1]

(d) $m = \underline{\hspace{2cm}}$ [2]

6. (a) Find the values of a , b , c and d in the figure below.
 (b) What type of angle is c° ?

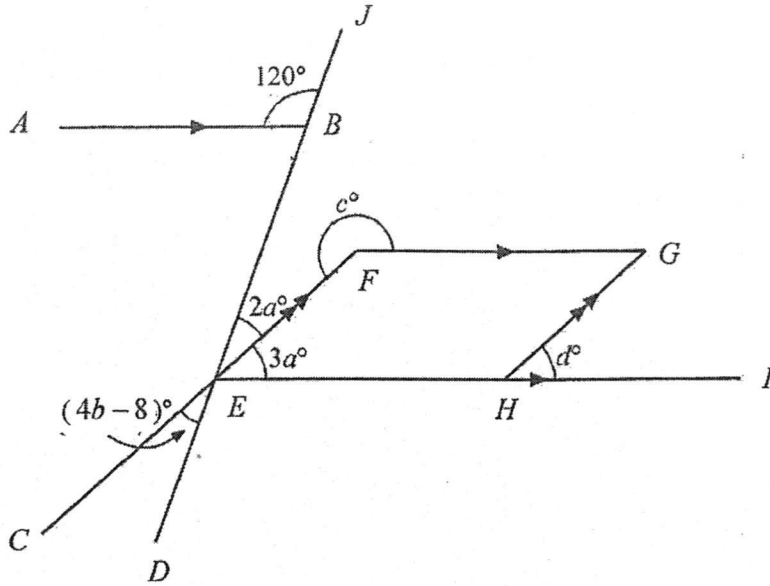

Ans: (a) $a =$ _____ [2]

$b =$ _____ [2]

$c =$ _____ [2]

$d =$ _____ [1]

(b) _____ angle [1]

7. A solid prism whose cross section is a trapezium is moulded into a solid cylinder of radius 10 cm. All dimensions given in the diagram are in centimetres.
- (a) Find the height of the cylinder, giving your answer correct to 3 significant figures.
- (b) Find the total surface area of the cylinder, giving your answer correct to the nearest whole number.

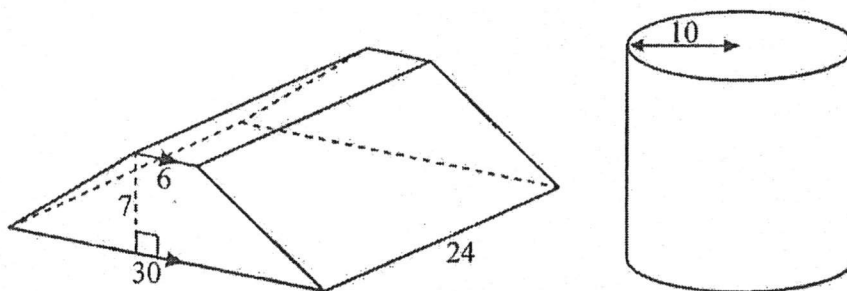

Ans: (a) _____ cm [4]
 (b) _____ cm² [3]

8. The line graph below shows the change in body temperature of a patient from 8 am to 11 pm. The temperatures are taken every 3 hours. The normal temperature of a person is approximately 37°C .

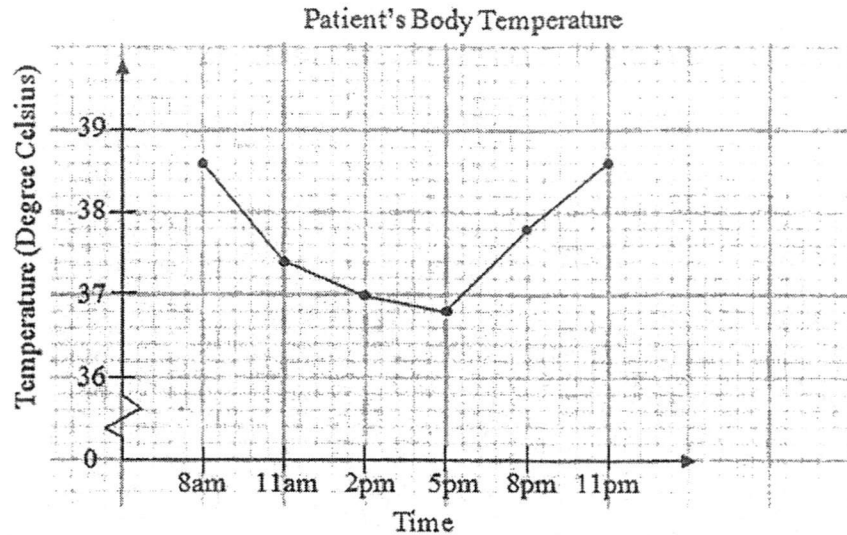

- (a) State the time taken (in hours) for his temperature to decline till it reaches normal temperature.
- (b) State a possible reason for the drop in the patient's temperature.

Ans: _____ [1]

- (d) Find the percentage increase in temperature from 5 pm to 8 pm.
- (e) Do you think the patient has recovered by 11 pm? Explain your answer.

Ans: _____ [2]

Ans: (a) _____ hours [1]

(d) _____ % [2]

-----END OF PAPER-----

SETTER: Ms Chow CW



AHMAD IBRAHIM SECONDARY SCHOOL

END OF YEAR EXAMINATION 2016

MATHEMATICS PAPER (100 Marks)

Level: Secondary 1 Express

DATE: 5th Oct 2016

DURATION: 2 hours 30 minutes

NAME: _____

CLASS: _____

INDEX NO: _____

ADDITIONAL MATERIALS:

Nil

READ THESE INSTRUCTIONS FIRST

Write your answers and working on all the separate writing papers provided.

Write your name, class and index number on all the work you hand in.

Write in dark blue or black pen.

You may use a pencil for any diagrams or graphs.

Do not use staples, paper clips, highlighters, glue or correction fluid.

Answer all questions in **Section A and Section B**.

If working is required for any question, it must be shown with the answer in the given space.

Omission of essential working will result in loss of marks.

Write your answers in the spaces provided on the question paper.

Calculators should be used where appropriate.

If the degree of accuracy is not specified in the question, and if the answer is not exact, give the answer to three significant figures. Give answer in degrees to one decimal place.

For π , use either your calculator value or 3.142, unless the question requires the answer in terms of π .

The number of marks is given in brackets [] at the end of each question or part question.

The total marks for this paper is 100.

SECTION A (50 Marks)

1. Consider the ten numbers: 1, 5, 8, 19, 47, 51, 111, 216, 999, 1000.

Write down

- (a) the composite numbers,
(b) the perfect cubes.

* Deduct one mark
for every error.

Ans: (a) 8, 216, 999, 1000, 51, 111 [2] B2
(b) 1, 8, 216, 1000. [2] B2

2. Find the value of $\sqrt[3]{13824}$ by using prime factorisation.

$$13824 = 2^9 \times 3^3 \quad [M1]$$

$$\sqrt[3]{13824} = \sqrt[3]{2^9 \times 3^3}$$

$$= 2^3 \times 3^1 \quad [M1]$$

$$= 24.$$

Ans: 24. [3] A1

3. If p and q are whole numbers such that $p \times q = 37$, find the value of $p + q$ and explain your answer.

$$\begin{aligned}
 p \times q &= 37 \\
 1 \times 37 &= 37 \\
 \therefore p + q &= 1 + 37 \\
 &= 38.
 \end{aligned}$$

Ans: $p + q =$ 38.

[1] A1

Explain: Since 37 is a prime number, it only has two factors > 1 and 37 itself. [B1]

[2]

4. (a) Determine whether the statement "If 2 and 4 are factors of a number, then 8 is also a factor of that number" is true or false.
 (b) If it is true, explain your reasoning. If it is false, give a counterexample.

Ans: (a) The above statement is false.

[1] B1

(b) If 4 is the number, 8 cannot be a factor of 4.

[1] B1

5. Consider the eight numbers: $(-0.5)^2$, 0 , $\sqrt[3]{-9}$, $\frac{18}{5}$, $\sqrt{100}$, $(-4)^3$, 17 , $-\frac{24}{3}$.

Write down

- (a) the positive numbers,
 (b) the integers.

* Deduct one mark for every error.

Ans: (a) $(-0.5)^2, \frac{18}{5}, \sqrt{100}, 17.$

[2] B2

(b) $0, \sqrt{100}, (-4)^3, 17, -\frac{24}{3}$

[2] B2

6. (a) Showing your working, express $100 \times 0.\dot{5}\dot{7}$ as a repeating decimal.

(b) Hence, find the value of $100 \times 0.\dot{5}\dot{7} - 0.\dot{5}\dot{7}$.

$$\begin{aligned} \text{(a)} \quad 100 \times 0.\dot{5}\dot{7} &= 100 \times 0.575757 \quad [\text{M1}] & \text{(a)} \quad 100 \times 0.\dot{5}\dot{7} \\ &= 57.5757 & &= 100 \times \frac{19}{33} \quad [\text{M1}] \\ &= 57.\dot{5}\dot{7} & &= 57.5757 \\ & & &= 57.\dot{5}\dot{7} \end{aligned}$$

$$\begin{aligned} \text{(b)} \quad 100 \times 0.\dot{5}\dot{7} - 0.\dot{5}\dot{7} \\ &= 57.\dot{5}\dot{7} - 0.\dot{5}\dot{7} \quad [\text{M1}] \\ &= 57 \end{aligned}$$

Ans: (a) 57. $\dot{5}\dot{7}$ [2] A1

(b) 57 [2] A1

7. Factorise the algebraic expression $4a - 8(b - 2c)$ completely.

$$\begin{aligned} &4a - 8(b - 2c) \\ &= 4a - 8b + 16c \quad [\text{M1}] \\ &= 4(a - 2b + 4c) \end{aligned}$$

Ans: 4(a - 2b + 4c) [2] A1

(6)

(a) If $z = -3^x - y^3$, find the value of z when $x = 2$ and $y = -3$.

(b) Simplify $(-2a) \times (-3b) + 5ba - 7a + 4b \times (-a) - a$.

$$\begin{aligned} \text{(a)} \quad z &= -3^x - y^3 \\ &= -3^2 - (-3)^3 \quad [M1] \\ &= -9 - (-27) \\ &= -9 + 27 \\ &= 18 \end{aligned}$$

$$\begin{aligned} \text{(b)} \quad &(-2a) \times (-3b) + 5ba - 7a + 4b \times (-a) - a \\ &= 6ab + 5ba - 7a + (-4ab) - a \quad [M1] \\ &= 6ab - 4ab + 5ba - 7a - a \\ &= 7ab - 8a. \end{aligned}$$

Ans: (a) $z = \underline{18}$ [2] A1

(b) $\underline{7ab - 8a}$ [2] A1

9. Solve the equation $\frac{2x+1}{x-3} = 2\frac{1}{3}$.

$$\frac{2x+1}{x-3} = \frac{7}{3}$$

$$\frac{3(2x+1)}{3(x-3)} = \frac{7(x-3)}{3(x-3)} \rightarrow \text{either step can get [M1].}$$

$$3(2x+1) = 7(x-3) \rightarrow$$

$$6x + 3 = 7x - 21$$

$$6x - 7x = -21 - 3 \cdot \text{[M1]}$$

$$-x = -24$$

$$x = 24$$

Ans: $x = \underline{24}$ [3] A1

(3)

10. Explain clearly in the space provided why $x = 40$ in the figure below. Show your working and reasoning clearly.

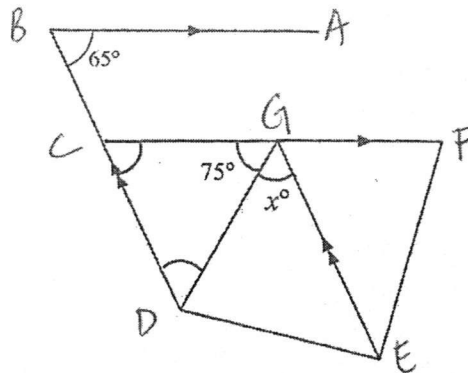

$$\angle DCB = 65^\circ \text{ (corr } \angle\text{s, } AB \parallel FC) \text{ [M1]}$$

$$\begin{aligned} \angle CDE &= 180^\circ - 65^\circ - 75^\circ \text{ (} \angle \text{sum of } \Delta) \text{ [M1]} \\ &= 40^\circ \end{aligned}$$

$$\angle x = 40^\circ \text{ (alt } \angle\text{s, } CD \parallel GE) \text{ [A1]}$$

$$\therefore x = 40$$

[3]

11. If the sum of the interior angles of a decagon (10-sided) is greater than the sum of the interior angles of another regular polygon by 540° , find the number of sides of the polygon.

$$\begin{aligned} \text{Sum of int } \angle\text{s of decagon} \\ &= (10-2) \times 180^\circ \text{ [M1]} \\ &= 1440^\circ \end{aligned}$$

$$\begin{aligned} (n-2) \times 180^\circ &= 900^\circ \text{ [M1]} \\ n-2 &= 900^\circ \div 180^\circ \\ &= 5. \end{aligned}$$

$$\begin{aligned} n &= 5+2 \\ &= 7. \end{aligned}$$

$$\begin{aligned} \text{Sum of int } \angle\text{s of another polygon} \\ &= 1440^\circ - 540^\circ \\ &= 900^\circ \end{aligned}$$

Ans: No. of sides = 7 [3] A1

12. An object moves 7.2 km in 1 hour. Find its speed in

- (a) metres per minute,
 (b) centimetres per second.

(a) 1 hour = 7.2 km.
 60 mins = 7200 m [M1]
 1 min = $7200 \div 60$
 = 120 m.

(b) 60 mins = 7200 m
 3600 s = 720000 cm [M1]
 1 s = $720000 \div 3600$
 = 200 cm.

* Part (b) can ECF for M1 if students used wrong part (a) answer.

Ans: (a) 120 m/min [2] A1
 (b) 200 cm/s [2] A1

13. (a) Solve the inequality $8x - 11x > -9$.
 (b) Illustrate the above solutions on a number line.

(a) $8x - 11x > -9$
 $-3x > -9$ [M1]
 $x < -9 \div (-3)$
 $x < 3$.

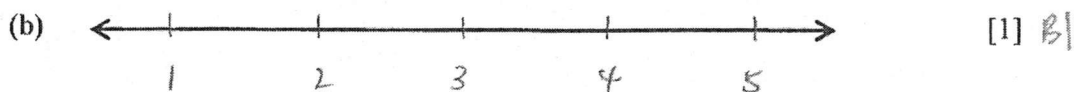
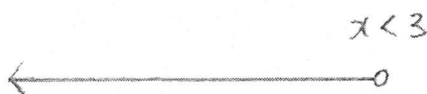

* ECF given for correct number line.

Ans: (a) $x < 3$ [2] A1

(X)

14. The diagram shows two semicircles with the same centre O . Measurements are in metres.

Find, in terms of π ,

- (a) the perimeter of the shaded region,
 (b) the area of the shaded region.

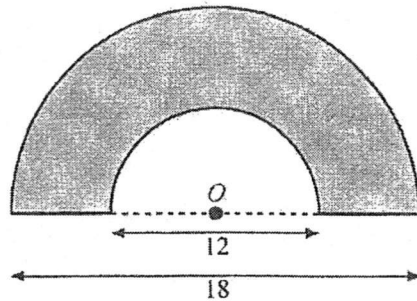

(a) Circumference of big semicircle

$$= \pi(9)$$

$$= 9\pi.$$

Circumference of small semicircle \swarrow either step can
 \nearrow get [M1].

$$= \pi(6)$$

$$= 6\pi.$$

$$\therefore \text{Perimeter} = 9\pi + 6\pi + 3 + 3$$

$$= 15\pi + 6.$$

(b) Area of big semicircle

$$= \frac{1}{2} \times \pi \times (9)^2$$

$$= 40.5\pi.$$

either step can get [M1] Area of small semicircle

$$= \frac{1}{2} \times \pi \times (6)^2$$

$$= 18\pi.$$

Ans: (a) $\frac{(15\pi + 6)}{\quad}$ m [2] A1

(b) $\frac{22.5\pi}{\quad}$ m² [2] A1

$$\therefore \text{Shaded area} = 40.5\pi - 18\pi$$

$$= 22.5\pi.$$

15. Tasnim earns \$85 on selling 80 tins of biscuits. If Tasnim bought 100 tins of biscuits for \$425, calculate

- (a) the cost of one tin of biscuits that Tasnim paid,
- (b) the profits of one tin of biscuits as a percentage of its cost.

(a) $100 \text{ tins} = \$425.$

$$\begin{aligned} 1 \text{ tin} &= \$425 \div 100 \\ &= \$4.25. \end{aligned}$$

(b) $80 \text{ tins} = \$85.$

$$\begin{aligned} 1 \text{ tin} &= \$85 \div 80 \quad [M1]. \\ &= \$1.0625. \end{aligned}$$

$$\begin{aligned} \frac{\text{earning}}{\text{cost}} \times 100\% &= \frac{1.0625}{4.25} \times 100\% \quad [M1]. \\ &= 25\%. \end{aligned}$$

Ans: (a) \$ 4.25. [1] A1

(b) 25. % [3] A1

TION B (50 Marks)

1. Ms Lim has 200 g of red plasticine, 380 g of grey plasticine and 420 g of yellow plasticine. She divided the plasticine into small balls of equal mass for her Art lesson.

Find

- (a) the largest possible mass of one small ball of plasticine,
 (b) the number of plasticine balls she obtained for each colour.

$$(a) \quad 200 = 2^3 \times 5^2$$

$$380 = 2^2 \times 5 \times 19.$$

$$420 = 2^2 \times 3 \times 5 \times 7$$

} [M1]

$$\begin{aligned} \text{HCF} &= 2^2 \times 5 \quad [M1] \\ &= 20. \end{aligned}$$

$$(b) \quad \begin{aligned} \text{Red} &= 200 \div 20 \\ &= 10. \end{aligned}$$

$$\begin{aligned} \text{Grey} &= 380 \div 20 \\ &= 19. \end{aligned}$$

$$\begin{aligned} \text{Yellow} &= 420 \div 20 \\ &= 21 \end{aligned}$$

Ans: (a) 20 g [3] A1

(b) 10 red balls [1] A1

19 grey balls [1] A1

21 yellow balls [1] A1

(6)

2. (a) Construct $\triangle ABC$ such that $AB = 5.5$ cm, $BC = 10$ cm and $AC = 5.5$ cm. [2] B2
 (b) Construct the perpendicular bisector of AC . [1] B1
 (c) Construct the angle bisector of $\angle CAB$. [1] B1

* labels and arcs have to be present.

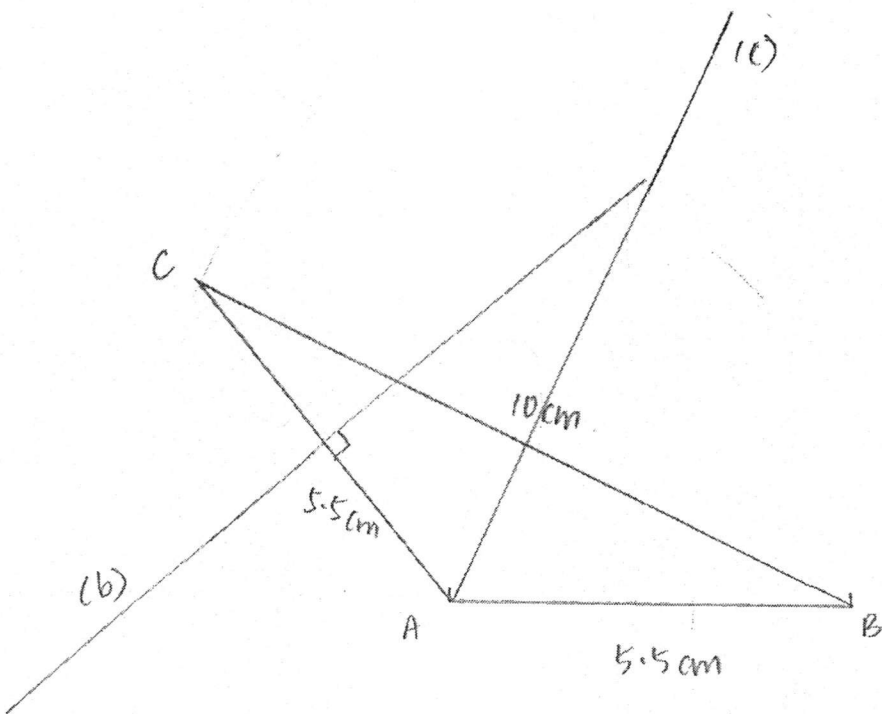

(4)

3. (a) The marks scored by a class of 20 students in a Mathematics test are as follows:

49 ✓ 46 ✓ 69 ✓ 61 ✓ 49 ✓
 50 ✓ 45 ✓ 62 ✓ 57 ✓ 69 ✓
 68 60 49 ✓ 59 57 ✓
 68 45 ✓ 55 ✓ 46 ✓ 50 ✓

Copy and complete the frequency table below.

[2] B2

Marks (x)	Tally	Frequency
$45 \leq x < 50$		7.
$50 \leq x < 55$		2.
$55 \leq x < 60$		4.
$60 \leq x < 65$		3.
$65 \leq x < 70$		4.

* Deduct one mark for every error.

- (b) Mei Xuan conducted a survey among a group of students who travel to school either by bus or by car. She displayed the data collected with a pictogram shown below.

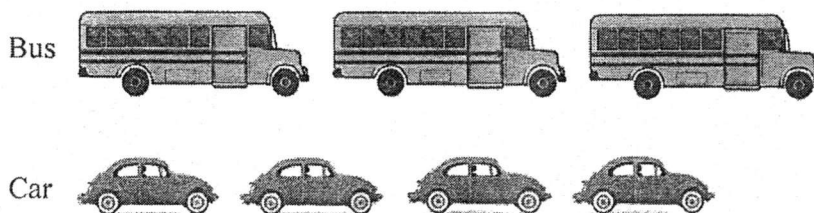

What is a possible misinterpretation of the above data and how would you modify the above pictogram to avoid misinterpretation?

It seems like there are more students taking bus. [B1]
 Ans: I will make the bus and car to be of the same size [B1]

[2]

4. Mave drove for a distance of 135 km at a speed of x km/h and Charmaine drove for a distance of 120 km at a speed 10 km/h slower than Mave. Given that the **time taken** by the both of them are the **same**, find the speed each of them drove at.

$$\text{Time taken by Mave} = \frac{135}{x}$$

$$\text{Time taken by Charmaine} = \frac{120}{x-10}$$

} [M1]

$$\frac{135}{x} = \frac{120}{x-10} \quad [M1]$$

$$\frac{135(x-10)}{x(x-10)} = \frac{120x}{x(x-10)}$$

either step can get [M1].

$$135(x-10) = 120x$$

$$135x - 1350 = 120x$$

$$135x - 120x = 1350$$

$$15x = 1350$$

$$x = 90 \quad [A1]$$

$$x - 10 = 90 - 10$$

$$= 80 \quad [A1]$$

Ans: Mave: 90 km/h

Charmaine: 80 km/h [5]

5. The diagram below shows the first three of a sequence of dot patterns.

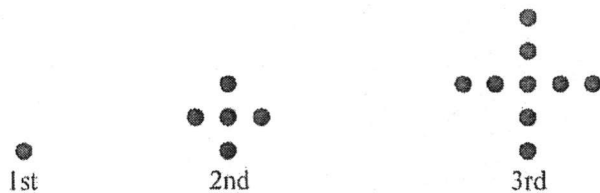

- (a) The information from the sequence of dots is tabulated below.
Complete the table. [1] B1

Pattern	Formula	Number of dots
1	1	1
2	4 + 1	5
3	4 + 4 + 1	9
4	4 + 4 + 4 + 1	13

- (b) Write down a formula, T_n to calculate the number of dots in the n th pattern.
 (c) Hence, find the number of dots in the 25th pattern.
 (d) Find the value of m if there are 501 dots in the m th pattern.

(b) $T_2 = 4 \times 1 + 1$
 $T_3 = 4 \times 2 + 1$
 $T_4 = 4 \times 3 + 1$
 $T_n = 4 \times (n-1) + 1$ [M1]
 $= 4n - 4 + 1$
 $= 4n - 3.$

(d) $T_m = 4(m) - 3.$
 $501 = 4m - 3.$ [M1]
 $4m = 501 + 3$
 $= 504$
 $m = 126.$

(c) $T_{25} = 4(25) - 3$
 $= 97.$

Ans: (b) $T_n = \underline{4n - 3}.$ [2] A1/B2

(c) $\underline{97}$ dots [1] A1

(d) $m = \underline{126}$ [2] A1

6. (a) Find the values of a , b , c and d in the figure below.
 (b) What type of angle is c° ?

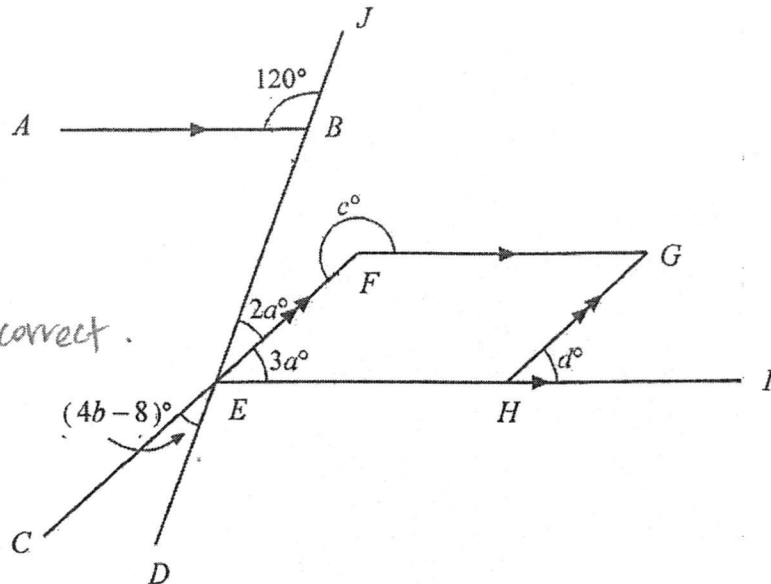

* M1 and A1 awarded when reasonings are correct.

(a) $\angle ABE = 180^\circ - 120^\circ$ (adj \angle s on str. line) [M1] $d^\circ = 3a^\circ$ (corr \angle s, $EF \parallel HG$)
 $= 60^\circ$ $= 3(12)^\circ$
 $= 36^\circ$

$2a^\circ + 3a^\circ = 60^\circ$ (alt \angle s, $AB \parallel EI$)

$5a^\circ = 60^\circ$

$a = 12$

Ans: (a) $a = \underline{12}$ [2] A1

$4b - 8 = 2a$ (vert opp \angle s) [M1]

$b = \underline{8}$ [2] A1

$4b - 8 = 2(12)$
 $= 24$

$c = \underline{216}$ [2] A1

$4b = 24 + 8$
 $= 32$

$d = \underline{36}$ [1] A1

$b = 8$

(b) Reflex angle [1] B1

$\angle EFG = 180^\circ - 3a^\circ$ (int \angle s, $EH \parallel FG$) [M1]

$= 180^\circ - 3(12)^\circ$

$= 144^\circ$

$c^\circ = 360^\circ - 144^\circ$ (\angle s at a point)
 $= 216^\circ$

7. A solid prism whose cross section is a trapezium is moulded into a solid cylinder of radius 10 cm. All dimensions given in the diagram are in centimetres.

- (a) Find the height of the cylinder, giving your answer correct to 3 significant figures.
- (b) Find the total surface area of the cylinder, giving your answer correct to the nearest whole number.

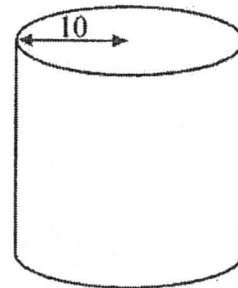
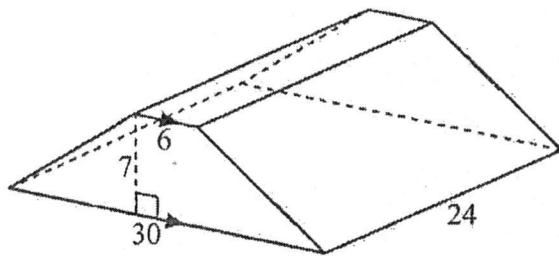

$$\begin{aligned} \text{(a) Area of trapezium} &= \frac{1}{2}(a+b)(h) \\ &= \frac{1}{2}(6+30)(7) \quad [\text{M1}] \\ &= 126 \text{ cm}^2 \end{aligned}$$

$$\begin{aligned} \text{Vol of prism} &= \text{BA} \times \text{Height} \\ &= 126 \times 24 \quad [\text{M1}] \\ &= 3024 \text{ cm}^3 \end{aligned}$$

$$\begin{aligned} \text{Area of circle} &= \pi(10)^2 \\ &= 314.16 \text{ cm}^2 \end{aligned}$$

$$\text{Vol of cylinder} = \text{BA} \times \text{Height}$$

$$3024 = 314.16 \times H \quad [\text{M1}]$$

$$\begin{aligned} H &= 9.6257 \\ &= 9.63 \text{ cm (3sf)} \end{aligned}$$

$$\begin{aligned} \text{(b) Perimeter of base} &= 2\pi(10) \\ &= 62.832 \end{aligned}$$

$$\begin{aligned} \text{SA} &= (62.832 \times 9.6257) + 2(314.16) \quad [\text{M1}] \\ &= 1233.12 \\ &= 1233 \text{ cm}^2 \end{aligned}$$

Ans: (a) 9.63 cm [4] A1

(b) 1233 cm² [3] A1

*Ecf for height.

(7)

8. The line graph below shows the change in body temperature of a patient from 8 am to 11 pm. The temperatures are taken every 3 hours. The normal temperature of a person is approximately 37°C .

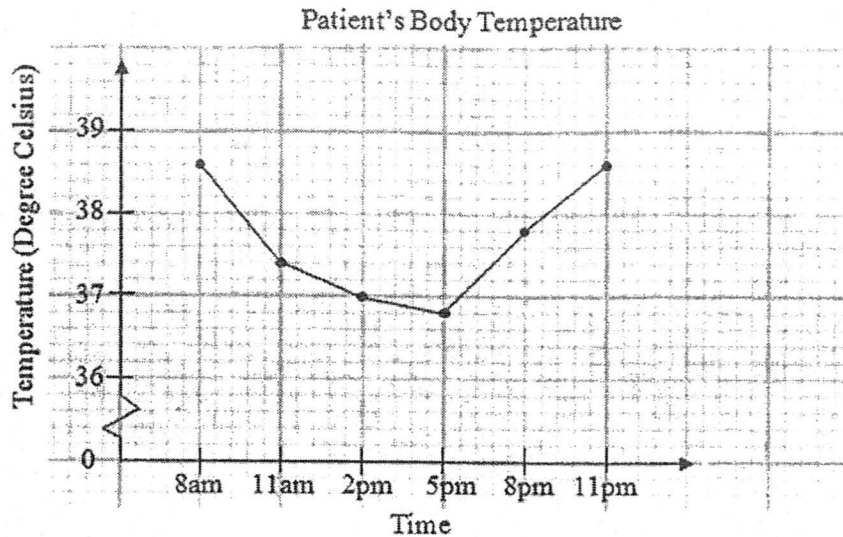

- (a) State the time taken (in hours) for his temperature to decline till it reaches normal temperature.
- (b) State a possible reason for the drop in the patient's temperature.

Ans: He has taken medicine [1] B1

- (d) Find the percentage increase in temperature from 5 pm to 8 pm.
- (e) Do you think the patient has recovered by 11 pm? Explain your answer.

Ans: NO. His temperature went up to 38.6°C . [2]

(d) Percentage Increase = $\frac{37.8 - 36.8}{36.8} \times 100\%$ [M1]

= $\frac{1}{36.8} \times 100\%$

= 2.72% (3sf).

Ans: (a) 6 hours [1] B1

(d) 2.72 % [2] A1

-----END OF PAPER-----

SETTER: Ms Chow CW