

Visit

FreeTestPaper.com

for more papers

INDEX NUMBER

--	--	--	--

**Anglo - Chinese School
(Independent)**



FINAL EXAMINATION 2016

**YEAR ONE EXPRESS
MATHEMATICS
PAPER 1**

Tuesday

11 OCTOBER 2016

1 hour

Candidates answer on the Question Paper.
No additional materials are required.

READ THESE INSTRUCTIONS FIRST

Write your index number on all the work you hand in.
Write in dark blue or black pen in the spaces provided on the Question Paper.
You may use a pencil for any diagrams or graphs.
Do not use staples, paper clips, highlighters, glue or correction fluid.

Answer **all** questions.
The number of marks is given in brackets [] at the end of each question or part question.
If working is needed for any question, it must be shown in the space below that question.
Omission of essential working will result in loss of marks.
The total of the marks for this paper is 40

NEITHER ELECTRONIC CALCULATORS NOR MATHEMATICAL TABLES MAY BE USED IN THIS PAPER.



For Examiner's Use

This question paper consists of 10 printed pages.

[Turn over

Answer **all** the questions

1 Simplify $9c - [7d - 2(4c - d)]$.

Answer _____ [2]

2 Evaluate $3 - \frac{2}{3} \div \left(-\frac{1}{2}\right)^2 \times \left(\frac{4}{5}\right)$.

Answer _____ [2]

- 3 Solve the inequality $-7y \leq -50 + 3y$.

Answer _____ [2]

- 4 The numbers 660 and 72, when written as the product of their prime factors, are
 $660 = 2^2 \times 3 \times 5 \times 11$,
 $72 = 2^3 \times 3^2$.

- (a) Find the HCF and LCM of 660 and 72, giving your answer as a product of prime factors.

Answer: (a) HCF = _____ [1]

LCM = _____ [1]

- (b) Hence, find the smallest number m that must be multiplied to 72 such that the product is a multiple of 660.

Answer (b) _____ [1]

[Turn over

- 5 (i) If eight students can assemble 76 toy cars in 2 hours, how many toy cars can ten students assemble in the same period of time?

Answer (i) _____ [1]

- (ii) Simplify $0.6 \text{ hour} : \frac{1}{3} \text{ hour} : 48 \text{ minutes}$.

Answer (ii) _____ [2]

-
- 6 (a) Factorize $ac - ab$ completely.

Answer (a) _____ [1]

- (b) Hence, find the value of $6300 - 63 \times 99$.

Answer (b) _____ [2]

- 7 In the diagram, AC is parallel to DF , $\angle AGD = 85^\circ$ and $\angle GAB = 72^\circ$.

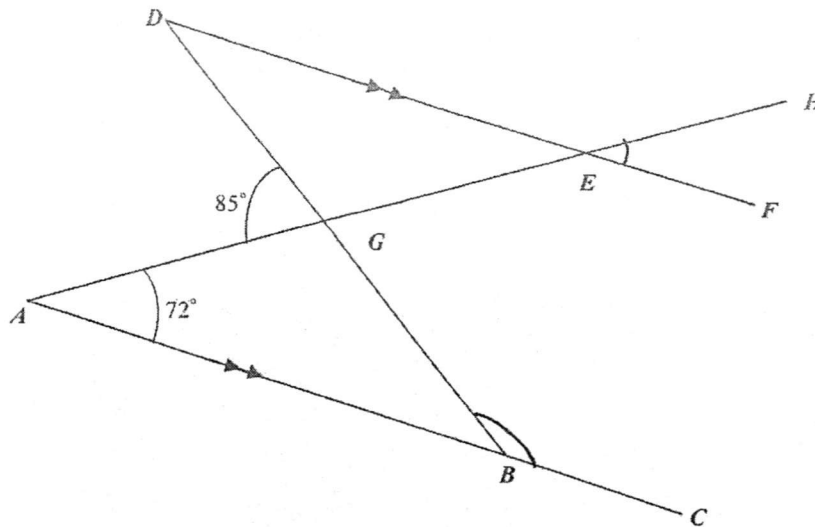

Find, stating your reasons clearly,

- (a) $\angle HEF$,

Answer (a) _____ [1]

- (b) $\angle GBC$.

Answer (b) _____ [2]

[Turn over

8 Evaluate $\frac{-\frac{1}{2} + 5}{1 - \frac{1}{\frac{1}{4} - \frac{2}{3}}}$.

Answer _____ [3]

- 9 (i) The co-ordinates of two points on a straight line graph are (0, 1) and (-2, 7). Find the equation of the straight line graph,

Answer (i) _____ [2]

- (ii) A square has the same perimeter as the circumference of a circle. If the area of the square is 484 cm^2 , what is the radius of the circle? (Take $\pi = \frac{22}{7}$)

Answer (ii) _____ [3]

[Turn over

10 (i) Solve $1.6(p-2)+1.2p=2.4$

Answer (i) _____ [2]

(ii) Express $\frac{2(2-k)}{3} - \frac{1}{4} + \frac{k-1}{2}$ as a single fraction in its simplest form.

Answer (ii) _____ [3]

- 11 (i) A man borrows \$3 500 from a bank that charges simple interest at the rate of 4% per annum. Find the total amount of money he has to pay to the bank at the end of 15 months.

Answer i) _____ [2]

- (ii) A digital TV set was sold at \$920 after a 20% discount.

- (a) Find the original price of the digital TV set.

Answer (ii)(a) _____ [1]

- (b) During a clearance sale, each digital TV set was sold at a 30% discount followed by another 5% on the discounted price. What was the selling price of each digital TV set during the clearance sale?

Answer (ii)(b) _____ [2]

[Turn over

- 12 (i) Construct a quadrilateral $ABCD$ where $AB = 7$ cm, $BC = 8$ cm, $\angle ABC = 80^\circ$, $\angle BCD = 60^\circ$ and $CD = 6$ cm. [2]
- (ii) Construct a perpendicular bisector of the line AB . [1]
- (iii) This perpendicular bisector meets the line CD at point X . Find the length of BX . [1]

END OF PAPER 1

Anglo - Chinese School

(Independent)



FINAL EXAMINATION 2016

YEAR ONE EXPRESS

MATHEMATICS

PAPER 2

Tuesday

11 October 2016

1 hour

Additional Materials:

Answer Paper (5 sheets)

READ THESE INSTRUCTIONS FIRST

Write your index number on every page of your answer script.

Write in dark blue or black pen.

You may use a pencil for any diagrams or graphs.

Do not use staples, paper clips, highlighters, glue or correction fluid.

Answer **all** questions.

If working is needed for any question, it must be shown with the answer.

Omission of essential working will result in loss of marks.

You are expected to use a scientific calculator to evaluate explicit numerical expressions.

If the degree of accuracy is not specified in the question, and if the answer is not exact, give the answer to three significant figures. Give answers in degrees to one decimal place.

For π , use either your calculator value or 3.142, unless the question requires the answer in terms of π .

At the end of the examination, fasten all your work together securely.

The number of marks is given in brackets [] at the end of each question or part question.

The total number of marks for this paper is 40.



This question paper consists of 4 printed pages.

[Turn over

Answer all the questions.

- 1 The table below shows part of Singapore Power Services bill.

Billing Period 06 Jul 2016 – 06 Aug 2016			
Breakdown of Current Charges	Usage	Rate	Total
Electricity Services	p kWh	\$0.1927	\$ q
Gas Services by City Gas Pte Ltd	15 kWh	\$0.1603	} \$3.23
	5 kWh	\$0.1660	
Subtotal			\$47.94

Find the value of

- (i) q , [1]
- (ii) p , leaving your answer correct to whole number. [2]
- 2 (a) Evaluate $\frac{(-2.65)^3 + 1.789}{0.987 - (-1.654)}$, leaving your answer correct to 3 significant figures. [1]
- (b) Identical cubic blocks are to be placed in an empty box.
- (i) If the dimension of the box is 42 cm by 18 cm by 12 cm, find the greatest length of each cube if the box is to be completely filled. [2]
- (ii) Hence, find the minimum number of cubes. [1]
- 3 (a) Mr Lim is a household appliances salesman who gets a basic salary of \$2 000 per month. For every electrical appliances he sold, he earned a 8% commission. For the month of June, he sold some electrical appliances which amount to \$12 800. What was his salary for June? [1]
- (b) John exchanged S\$4 000 for British Pounds when he went to London. At that time, the exchange rate was £1 = S\$1.77.
- (i) Calculate the amount of pounds he received, correct to the nearest whole number. [1]
- He spent £1 847 in London. When he returned to Singapore, he decided to exchange his remaining pounds back to Singapore dollars.
- (ii) Given that the exchange rate was S\$1 = £0.575, calculate the amount of Singapore dollars he received, correct to the nearest whole number. [2]

- 4 The diagram below shows a line graph for the number of dengue fever cases over the past 7 weeks.

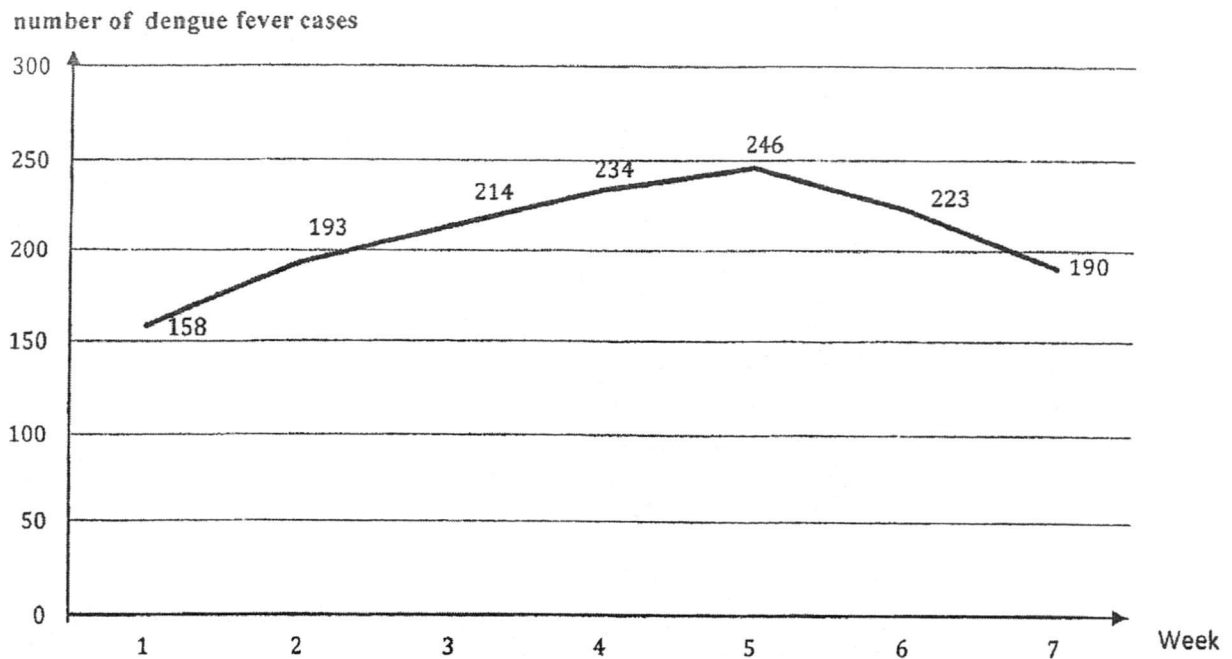

- (a) Find the average number of dengue fever cases, giving your answer correct to the nearest whole number, reported for the 7 weeks. [2]
- (b) Find the percentage increase of the number of dengue fever cases between week 2 and week 5, giving your answer correct to 3 significant figures. [2]
- 5 The first five numbers in a sequence are $-2, 1, 4, 7$ and 10 .
- (a) Find the next two terms. [1]
- (b) Find the n^{th} term of this sequence. [2]
- (c) Find the 55^{th} term of this sequence. [1]
- (d) Is it possible to have the number 359 in the sequence? Support your answer with detailed workings. [2]
- 6 (a) Solve the equation $\frac{2}{3}(x-3) - \frac{5}{4}(1-3x) = \frac{1}{2}(3x-4)$. [3]
- (b) Factorise $\frac{x(p-3)}{3} + 6(3-p)$. [2]

- 7 A door stopper was made by removing a right-angled triangular block from a rectangular block of wood of dimension 12 cm by 4 cm by 6 cm.

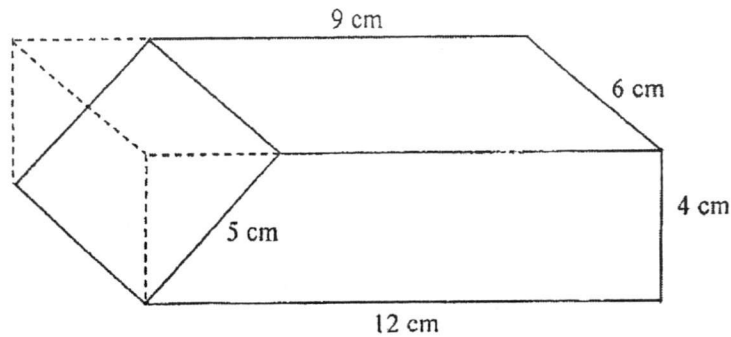

- (a) Calculate the volume of the door stopper. [3]
- (b) Calculate the total surface area of the door stopper. [3]
- 8 (a) Given that each interior angle of a regular n -sided polygon is 78° more than each exterior angle of a regular pentagon, form an equation in n and solve it. [4]
- (b) Edward drove at 70 km/h from Town X to Town Y . The distance between Town X and Y is 119 km.
- (i) Find the time he took to reach his destination. [1]
- When he drove back, he decided to increase his speed by x km/h.
- (ii) Write down an expression, in terms of x , for the time he took for his return journey. [1]
- He planned to spend at most 1 hour and 20 mins for his return journey.
- (iii) Form an inequality in x and find the minimum integer value of x . [2]

..... End of Paper 2

INDEX NUMBER

--	--	--	--

**Anglo - Chinese School
(Independent)**



FINAL EXAMINATION 2016

**YEAR ONE EXPRESS
MATHEMATICS
PAPER 1**

Tuesday

11 OCTOBER 2016

1 hour

Candidates answer on the Question Paper.
No additional materials are required.

READ THESE INSTRUCTIONS FIRST

Write your index number on all the work you hand in.
Write in dark blue or black pen in the spaces provided on the Question Paper.
You may use a pencil for any diagrams or graphs.
Do not use staples, paper clips, highlighters, glue or correction fluid.

Answer all questions.

The number of marks is given in brackets [] at the end of each question or part question.

If working is needed for any question, it must be shown in the space below that question.

Omission of essential working will result in loss of marks.

The total of the marks for this paper is 40

NEITHER ELECTRONIC CALCULATORS NOR MATHEMATICAL TABLES MAY BE USED IN THIS PAPER.



For Examiner's Use

--

This question paper consists of 10 printed pages.

[Turn over

Answer all the questions

1 Simplify $9c - [7d - 2(4c - d)]$.

$$\begin{aligned} &= 9c - [7d - 8c + 2d] \\ &= 9c - [9d - 8c] \\ &= 9c - 9d + 8c \\ &= \underline{17c - 9d} \end{aligned}$$

Answer 17c - 9d [2]

2 Evaluate $3 - \frac{2}{3} \div \left(-\frac{1}{2}\right)^2 \times \left(\frac{4}{5}\right)$.

$$\begin{aligned} &3 - \frac{2}{3} \div \left(-\frac{1}{2}\right)^2 \times \left(\frac{4}{5}\right) \\ &= \frac{3}{1} - \frac{2}{3} \div \frac{1}{4} \times \frac{4}{5} \\ &= \frac{3}{1} - \frac{2}{3} \times \frac{4}{1} \times \frac{4}{5} \\ &= \frac{3}{1} - \frac{8}{3} \times \frac{4}{5} \\ &= \frac{3}{1} - \frac{32}{15} \\ &= \frac{45}{15} - \frac{32}{15} \\ &= \underline{\frac{13}{15}} \end{aligned}$$

Answer $\frac{13}{15}$ [2]

- 3 Solve the inequality $-7y \leq -50 + 3y$.

$$\begin{aligned} -7y &\leq -50 + 3y \\ -7y - 3y &\leq -50 \\ -10y &\leq -50 \\ 10y &\geq 50 \\ y &\geq 5 \end{aligned}$$

Answer $y \geq 5$ [2]

- 4 The numbers 660 and 72, when written as the product of their prime factors, are

$$660 = 2^2 \times 3 \times 5 \times 11,$$

$$72 = 2^3 \times 3^2.$$

- (a) Find the HCF and LCM of 660 and 72, giving your answer as a product of prime factors.

$$660 = 2^2 \times 3 \times 5 \times 11$$

$$72 = 2^3 \times 3^2$$

HCF \rightarrow lowest power per factor (both numbers 660 & 72 must have a factor)

LCM \rightarrow highest power per factor.

$$\text{HCF} \rightarrow 2^2 \times 3 = \underline{12} \#$$

$$\text{LCM} \rightarrow 2^3 \times 3^2 \times 5 \times 11 = \underline{3960} \#$$

Answer: (a) HCF = 12 [1]

LCM = 3960 [1]

- (b) Hence, find the smallest number m that must be multiplied to 72 such that the product is a multiple of 660.

$$\begin{array}{r} 0055 \\ 72 \overline{) 3960} \\ \underline{-0} \\ 39 \\ \underline{-0} \\ 390 \\ \underline{-360} \\ 0360 \\ \underline{-0360} \\ 0000 \end{array}$$

LCM of 72 and 660 $\rightarrow 3960$

$$m = 3960 \div 72 = \underline{55} \#$$

Answer (b) 55 [1]

[Turn over

- 5 (i) If eight students can assemble 76 toy cars in 2 hours, how many toy cars can ten students assemble in the same period of time?

$$\frac{\text{no. of students}}{8} \quad \frac{\text{no. of toy cars}}{76} \quad \frac{\text{time}}{2\text{h}}$$

$$2 \text{ students (in 2 hours)} \longrightarrow 76 \div 4 = 19$$

$$10 \text{ students (in 2 hours)} = 19 \times 5 = \underline{95} \#$$

Answer (i) 95 toy cars [1]

- (ii) Simplify 0.6 hour : $\frac{1}{3}$ hour : 48 minutes.

$$0.6 \text{ hour} = 0.6 \times 60 \text{ mins} = 36 \text{ mins}$$

$$\frac{1}{3} \text{ hour} = \frac{1}{3} \times 60 \text{ mins} = 20 \text{ mins}$$

$$36 \text{ mins} : 20 \text{ mins} : 48 \text{ mins}$$

$$18 \text{ mins} : 10 \text{ mins} : 24 \text{ mins}$$

$$9 \text{ mins} : 5 \text{ mins} : 12 \text{ mins}$$

$$\underline{9 : 5 : 12} \#$$

Answer (ii) 9 : 5 : 12 [2]

- 6 (a) Factorize $ac - ab$ completely.

$$\begin{array}{l|l} a & ac, ab \\ \hline & c, b \end{array}$$

$$\therefore ac - ab \text{ (factorised)} \rightarrow a(c-b) \text{ Answer (a) } \underline{a(c-b)} \quad [1]$$

- (b) Hence, find the value of $6300 - 63 \times 99$.

$$6300 - 63 \times 99$$

$$6300 = 63 \times 100$$

$$\text{Hence, } 63 \times 100 - 63 \times 99$$

$$= 63 \times 1$$

$$= \underline{63} \#$$

Answer (b) 63 [2]

- 7 In the diagram, AC is parallel to DF , $\angle AGD = 85^\circ$ and $\angle GAB = 72^\circ$.

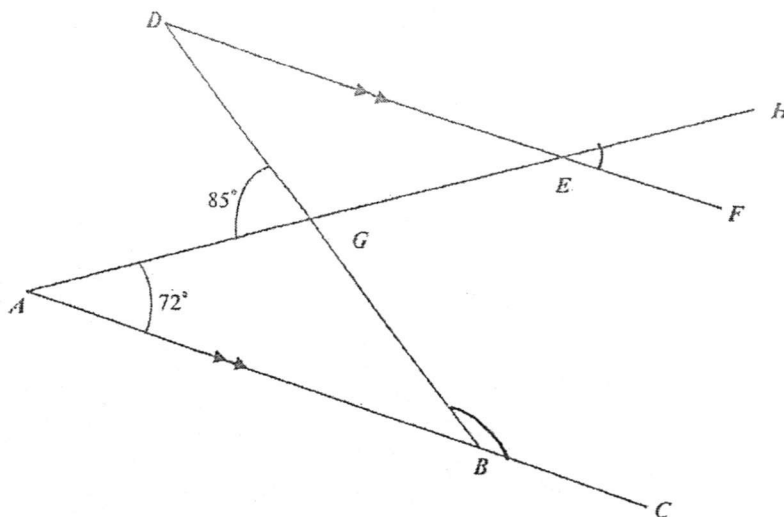

Find, stating your reasons clearly,

- (a) $\angle HEF$,
 $\angle BAG = \angle GED = \angle HEF$ (alternate angles and vertically opposite angles)
 $\therefore \angle BAG = 72^\circ$
 $\angle HEF = 72^\circ$

Answer (a) 72° [1]

- (b) $\angle GBC$.

$$\begin{aligned} \angle AGB &\rightarrow 180^\circ - 85^\circ = \underline{95^\circ} \text{ (angles on a straight line)} \\ \angle GBA &\rightarrow 180^\circ - 95^\circ - 72^\circ = \underline{13^\circ} \text{ (angles of a triangle)} \\ \angle GBC &\rightarrow 180^\circ - 13^\circ = \underline{167^\circ} \text{ (angles on a straight line)} \end{aligned}$$

Answer (b) 167° [2]

[Turn over

8 Evaluate $\frac{-\frac{1}{2}+5}{1-\frac{1}{\frac{1-\frac{2}{4}-\frac{2}{3}}{1}}}$

$$= \frac{-\frac{1}{2} + \frac{5}{1}}{1 - \frac{1}{\frac{3}{12} - \frac{8}{12}}}$$

$$= \frac{-\frac{1}{2} + \frac{10}{2}}{1 - \frac{1}{-\frac{5}{12}}}$$

$$= \frac{\frac{9}{2}}{1 - \frac{12}{-5}}$$

$$= \frac{\frac{9}{2}}{1 - \frac{12}{-5}}$$

$$= \frac{\frac{9}{2}}{1 - (-\frac{12}{5})}$$

$$= \frac{\frac{9}{2}}{\frac{5}{5} + \frac{12}{5}}$$

(CONTINUATION ...)

$$= \frac{\frac{9}{2}}{\frac{17}{5}}$$

$$= \frac{45}{10}$$

$$= \frac{34}{10}$$

$$= \frac{45}{34}$$

$$= \frac{11}{34} \#$$

Answer $\frac{11}{34}$ [3]

- 9 (i) The co-ordinates of two points on a straight line graph are (0, 1) and (-2, 7). Find the equation of the straight line graph,

$$\begin{aligned} \text{Gradient of line} &= \frac{y_1 - y_2}{x_1 - x_2} \\ &= \frac{1 - 7}{0 - (-2)} \\ &= \frac{-6}{2} \\ &= -\frac{6}{2} \\ &= -\frac{3}{1} \\ &= -3 \end{aligned}$$

Taking point (-2, 7)

$$7 = -3x(-2) + c$$

$$(y = m \times x + c)$$

$c \rightarrow y$ intercept

$$7 = 6 + c$$

$$7 - 6 = c$$

$$1 = c$$

$$\therefore \text{equation of graph} \rightarrow y = -3x + 1 \#$$

Answer (i) $y = -3x + 1$ [2]

- (ii) A square has the same perimeter as the circumference of a circle. If the area of the square is 484 cm^2 , what is the radius of the circle? (Take $\pi = \frac{22}{7}$)

$$\text{Length of square} = \sqrt{484 \text{ cm}^2} = 22 \text{ cm}$$

$$\text{Circumference of circle} = \frac{22}{7} \times \text{diameter} \rightarrow 22 \text{ cm} \times 4 = 88 \text{ cm}$$

$$\frac{22}{7} \times \text{diameter} = 88 \text{ cm}$$

$$\text{diameter} = \frac{88}{1} \div \frac{22}{7}$$

$$\text{diameter} = \frac{88}{1} \times \frac{7}{22}$$

$$\text{diameter} = \frac{616}{22}$$

$$\text{diameter} = 28 \text{ cm}$$

$$\text{radius} \rightarrow 28 \text{ cm} \div 2$$

$$= 14 \text{ cm} \#$$

Answer (ii) 14 cm [3]

[Turn over

10 (i) Solve $1.6(p-2)+1.2p=2.4$

$$1.6(p-2) + 1.2p = 2.4$$

$$1.6p - 3.2 + 1.2p = 2.4$$

$$2.8p - 3.2 = 2.4$$

$$2.8p = 2.4 + 3.2$$

$$2.8p = 5.6$$

$$p = 2$$

Answer (i) $p = 2$ [2]

(ii) Express $\frac{2(2-k)}{3} - \frac{1}{4} + \frac{k-1}{2}$ as a single fraction in its simplest form.

$$\frac{2(2-k)}{3} - \frac{1}{4} + \frac{k-1}{2}$$

$$= \frac{4-2k}{3} - \frac{1}{4} + \frac{k-1}{2}$$

$$= \frac{16-8k-3+(6k-6)}{12}$$

$$= \frac{16-3-6-8k+6k}{12}$$

$$= \frac{7-2k}{12}$$

Answer (ii) $\frac{7-2k}{12}$ [3]

- 11 (i) A man borrows \$3 500 from a bank that charges simple interest at the rate of 4% per annum. Find the total amount of money he has to pay to the bank at the end of 15 months.

$$\begin{aligned} \text{per annum} &= 12 \text{ months} \\ \text{rate} &= 4\% \\ 15 \text{ months} &= 1\frac{1}{4} \text{ years} \\ &= \$140 \times 1\frac{1}{4} \\ &= \$140 + \$35 \\ &= \$175 \end{aligned}$$

$$\begin{aligned} \text{Simple interest paid} &= \text{principal} \times \text{rate} \times \text{time (years)} \\ &= \$3500 \times 4\% \times 1\frac{1}{4} \\ \text{interest} + \text{amount borrowed} &= \$3500 + \$175 \\ &= \underline{\underline{\$3675}} \end{aligned}$$

Answer i) \$ 3675 [2]

- (ii) A digital TV set was sold at \$920 after a 20% discount.

- (a) Find the original price of the digital TV set.

$$\begin{aligned} 100\% - 20\% &= 80\% \\ 80\% &= \$920 \\ 20\% &= \$920 \div 4 = \$230 \\ \text{Original price} &= \$230 \times 5 = \$1150 \end{aligned}$$

Answer (ii)(a) \$ 1150 [1]

- (b) During a clearance sale, each digital TV set was sold at a 30% discount followed by another 5% on the discounted price. What was the selling price of each digital TV set during the clearance sale?

$$\begin{aligned} 100\% - 30\% &= 70\% \\ \text{(Final) discounted price (\%)} &= 70\% - 5\% \text{ of } 70\% \\ 5\% \text{ of } 70\% &= 70\% \div 20 = 3.5\% \\ \text{Final discounted price (\%)} &= 70\% - 3.5\% = 66.5\% \\ \text{Discounted price of digital TV} &= 66.5\% \times \$1150 \\ &= \$764.75 \end{aligned}$$

Answer (ii)(b) \$ 764.75 [2]

[Turn over

- 12 (i) Construct a quadrilateral $ABCD$ where $AB = 7\text{ cm}$, $BC = 8\text{ cm}$, $\angle ABC = 80^\circ$, $\angle BCD = 60^\circ$ and $CD = 6\text{ cm}$. [2]
- (ii) Construct a perpendicular bisector of the line AB . [1]
- (iii) This perpendicular bisector meets the line CD at point X . Find the length of BX . [1]

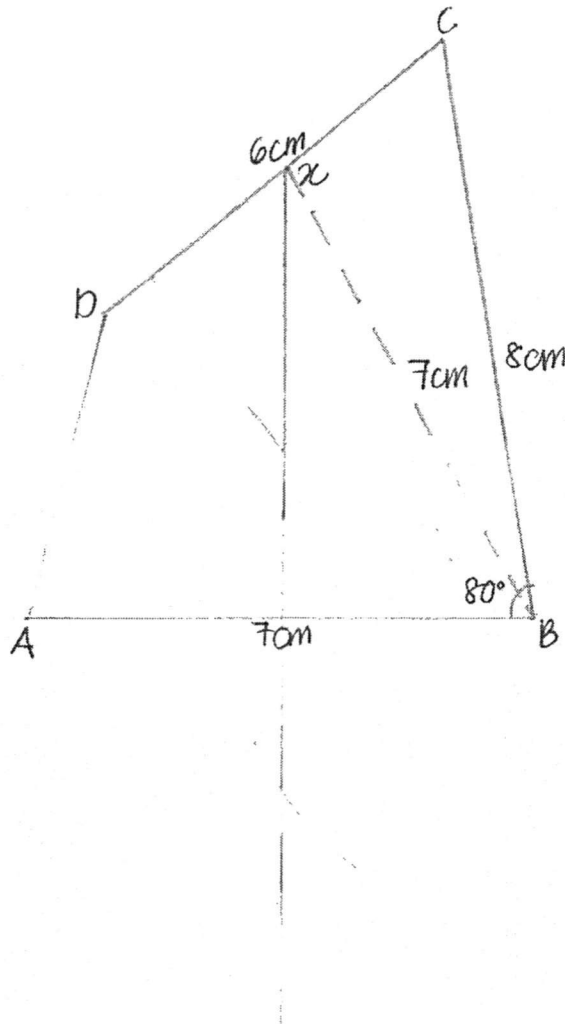

(iii) $BX = 7\text{ cm}$ (shown)

END OF PAPER 1

Anglo - Chinese School

(Independent)



FINAL EXAMINATION 2016

YEAR ONE EXPRESS

MATHEMATICS

PAPER 2

Tuesday

11 October 2016

1 hour

Additional Materials:

Answer Paper (5 sheets)

READ THESE INSTRUCTIONS FIRST

Write your index number on every page of your answer script.

Write in dark blue or black pen.

You may use a pencil for any diagrams or graphs.

Do not use staples, paper clips, highlighters, glue or correction fluid.

Answer all questions.

If working is needed for any question, it must be shown with the answer.

Omission of essential working will result in loss of marks.

You are expected to use a scientific calculator to evaluate explicit numerical expressions.

If the degree of accuracy is not specified in the question, and if the answer is not exact, give the answer to three significant figures. Give answers in degrees to one decimal place.

For π , use either your calculator value or 3.142, unless the question requires the answer in terms of π .

At the end of the examination, fasten all your work together securely.

The number of marks is given in brackets [] at the end of each question or part question.

The total number of marks for this paper is 40.



This question paper consists of 4 printed pages.

[Turn over

Answer all the questions.

1 The table below shows part of Singapore Power Services bill.

Billing Period 06 Jul 2016 – 06 Aug 2016			
Breakdown of Current Charges	Usage	Rate	Total
Electricity Services	p kWh	\$0.1927	\$ q
Gas Services by City Gas Pte Ltd	15 kWh	\$0.1603	} \$3.23
	5 kWh	\$0.1660	
Subtotal			\$47.94

Find the value of

- (i) q , [1]
- (ii) p , leaving your answer correct to whole number. [2]
- 2 (a) Evaluate $\frac{(-2.65)^3 + 1.789}{0.987 - (-1.654)}$, leaving your answer correct to 3 significant figures. [1]
- (b) Identical cubic blocks are to be placed in an empty box.
- (i) If the dimension of the box is 42 cm by 18 cm by 12 cm, find the greatest length of each cube if the box is to be completely filled. [2]
- (ii) Hence, find the minimum number of cubes. [1]
- 3 (a) Mr Lim is a household appliances salesman who gets a basic salary of \$2 000 per month. For every electrical appliances he sold, he earned a 8% commission. For the month of June, he sold some electrical appliances which amount to \$12 800. What was his salary for June? [1]
- (b) John exchanged S\$4 000 for British Pounds when he went to London. At that time, the exchange rate was £1 = S\$1.77.
- (i) Calculate the amount of pounds he received, correct to the nearest whole number. [1]
- He spent £1 847 in London. When he returned to Singapore, he decided to exchange his remaining pounds back to Singapore dollars.
- (ii) Given that the exchange rate was S\$1 = £0.575, calculate the amount of Singapore dollars he received, correct to the nearest whole number. [2]

- 4 The diagram below shows a line graph for the number of dengue fever cases over the past 7 weeks.

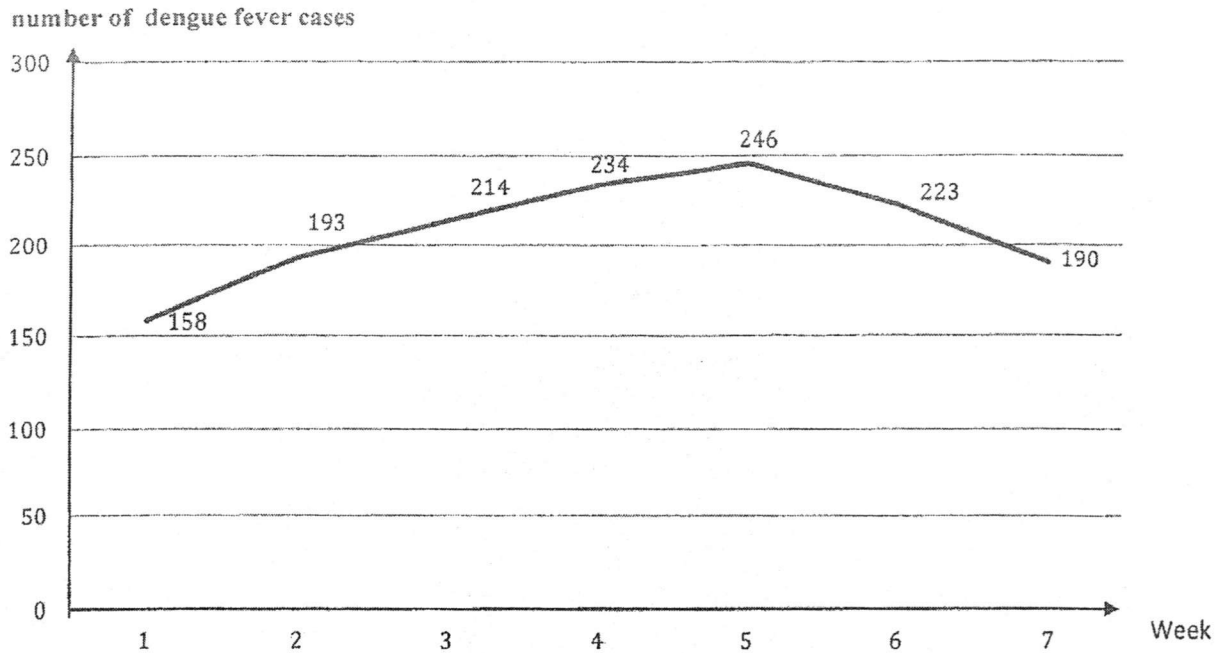

- (a) Find the average number of dengue fever cases, giving your answer correct to the nearest whole number, reported for the 7 weeks. [2]
- (b) Find the percentage increase of the number of dengue fever cases between week 2 and week 5, giving your answer correct to 3 significant figures. [2]

- 5 The first five numbers in a sequence are -2 , 1 , 4 , 7 and 10 .

- (a) Find the next two terms. [1]
- (b) Find the n^{th} term of this sequence. [2]
- (c) Find the 55^{th} term of this sequence. [1]
- (d) Is it possible to have the number 359 in the sequence? Support your answer with detailed workings. [2]

6 (a) Solve the equation $\frac{2}{3}(x-3) - \frac{5}{4}(1-3x) = \frac{1}{2}(3x-4)$. [3]

(b) Factorise $\frac{x(p-3)}{3} + 6(3-p)$. [2]

$$\frac{x(p-3)}{3} + \frac{6(3-p)}{3}$$

- 7 A door stopper was made by removing a right-angled triangular block from a rectangular block of wood of dimension 12 cm by 4 cm by 6 cm.

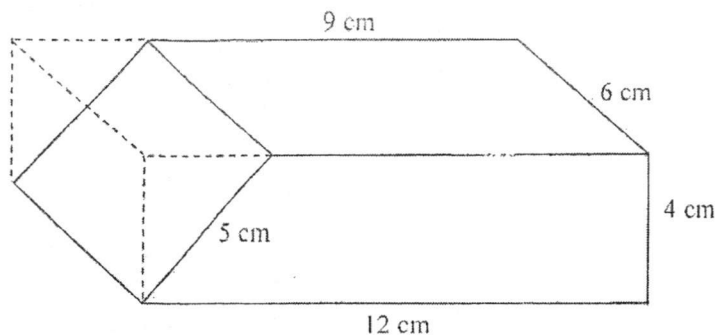

- (a) Calculate the volume of the door stopper. [3]
- (b) Calculate the total surface area of the door stopper. [3]
- 8 (a) Given that each interior angle of a regular n -sided polygon is 78° more than each exterior angle of a regular pentagon, form an equation in n and solve it. [4]
- (b) Edward drove at 70 km/h from Town X to Town Y . The distance between Town X and Y is 119 km.
- (i) Find the time he took to reach his destination. [1]
- When he drove back, he decided to increase his speed by x km/h.
- (ii) Write down an expression, in terms of x , for the time he took for his return journey. [1]
- He planned to spend at most 1 hour and 20 mins for his return journey.
- (iii) Form an inequality in x and find the minimum integer value of x . [2]

..... End of Paper 2

Subject:

No.

Date:

2016 ACS(I) FINAL EXAMINATION, YEAR 1 EXPRESS, MATHEMATICS PAPER 2

$$1(i) q = \$47.94 - \$3.23 = \$44.71$$

$$q = \$44.71$$

$$1(ii) \$44.71 \div 0.1927 = 232 \text{ (to the nearest whole no.)}$$

$$p = 232$$

$$p \text{ is } \underline{232} \#$$

$$2(a) \frac{(-2.05)^3 \div 1.789}{0.987 - (-1.054)} = -3.94 \text{ (to 3 s.f.)}$$

2(b)(i)	2	42, 18, 12
	3	21, 9, 6
		7, 3, 2

$$\text{HCF} = 2 \times 3$$

$$= 6$$

Hence, the greatest length of each cube if the box is filled is 6cm #

$$2(b) \text{ Number of cubes that can fit in } \Rightarrow 42\text{cm} \div 6\text{cm} = 7 \text{ cubes}$$

$$\text{Number of cubes that can fit in width } \Rightarrow 18\text{cm} \div 6\text{cm} = 3 \text{ cubes}$$

$$\text{Number of cubes on first level } \Rightarrow 7 \times 3 = 21 \text{ cubes}$$

$$\text{Number of cubes on height } \Rightarrow 12\text{cm} \div 6\text{cm} = 2 \text{ cubes}$$

$$\text{Total number of cubes that can fit in } \Rightarrow 21 \times 2 = \underline{42 \text{ cubes}} \#$$

$$3(a) 8\% \text{ of } \$12800 = \frac{8}{100} \times \$12800 = \$1024$$

$$\text{Salary for June} = \$1024 + \$2000$$

$$= \underline{\$3024} \#$$

$$3(b) \text{ i. amount of pounds received} = \$4000 \div \$1.77$$

$$= 2260 \text{ pounds (to the nearest whole no.)}$$

$$(b) \text{ ii. } 2260 \text{ pounds} - 1847 \text{ pounds} = 413 \text{ pounds}$$

$$413 \text{ pounds} \div 0.575 \text{ pounds} = 718 \text{ (to the nearest whole no.)}$$

He received 718 Singapore dollars.

$$4(a) \text{ Total cases reported} \rightarrow 158 + 193 + 214 + 234 + 246 + 223 + 190$$

$$= 1458$$

$$\text{Average per week} = 1458 \div 7$$

$$= 208 \text{ (to the nearest whole no.)}$$

$$4(b) \text{ Week 2} = 193$$

$$\text{Week 5} = 246$$

$$\text{Difference} = 246 - 193$$

$$= 53$$

$$\therefore \text{Percentage increase from Week 2 to Week 5} = \frac{53}{193} \times 100\%$$

$$= 27.461\% \text{ (to 3 s.f.)}$$

$$5(a) \text{ 13 and 16}$$

$$5(b) \text{ number of intervals between terms} = T_n - 1$$

$$\therefore -2 + [(T_n - 1) \times 3]$$

$$= -2 + 3T_n - 3$$

$$n^{\text{th}} \text{ term of sequence} = -2 + 3n - 3$$

$$= -2 - 3 + 3n$$

$$= 3n - 5 \quad \#$$

$$5(c) \text{ } 55 - 1 = 54$$

$$-2 + 54 \times 3 = 100 \quad \#$$

Subject:

No:

Date:

5(d) number of intervals between terms = $T_n - 1$ Hence, formula for sequence = -2 (1st term) + $[(T_n - 1) \times 3]$
intervals

$$= -2 + [(T_n - 1) \times 3]$$

$$= -2 + 3T_n - 3$$

$$359 = -2 + 3T_n - 3$$

$$359 + 2 + 3 = 3T_n$$

$$364 = 3T_n$$

$$121\frac{1}{3} = T_n$$

Term number is not whole. Therefore, 359 is not in the number sequence.

$$6(a) \quad \frac{2}{3}(x-3) - \frac{5}{4}(1-3x) = \frac{1}{2}(3x-4)$$

$$\frac{2}{3}x - 2 - \left(\frac{5}{4} - \frac{3}{4}x\right) = 1.5x - 2$$

$$\frac{15}{4}x + \frac{2}{3}x - 2 - 1\frac{1}{4} = 1.5x - 2$$

$$\frac{45+8}{12}x - 3\frac{1}{4} = 1.5x - 2$$

$$\frac{53}{12}x - 3\frac{1}{4} = 1.5x - 2$$

$$\left(4\frac{5}{12}\right)x - 3\frac{1}{4} = 1.5x - 2$$

$$4\frac{5}{12}x - 1.5x = 3\frac{1}{4} - 2$$

$$\frac{53}{12}x - \frac{3}{2}x = 1\frac{1}{4}$$

$$\frac{53}{12}x - \frac{18}{12}x = 1\frac{1}{4}$$

$$\frac{35}{12}x = 1\frac{1}{4}$$

$$\frac{1}{12}x = \frac{1}{28}$$

$$x = \frac{3}{7} \neq$$

$$6(b) \quad \frac{x(p-3)}{3} + 6(3-p)$$

$$= \frac{x(p-3)}{3} + \frac{6(3-p)}{1}$$

$$= \frac{x(p-3)}{3} + \frac{18-6p}{1}$$

$$= \frac{x(p-3)}{3} + \frac{54-18p}{3}$$

HCF of 54 and 18 $\rightarrow 3^2 \times 2 = 18$

3	54, 18
3	18, 6
2	6, 2
	3, 1

$$= \frac{x(p-3) + 18(3-p)}{3}$$

$$= \frac{x(p-3) + 18(3-p)}{3}$$

$$= \frac{x(p-3) - 18(p-3)}{3}$$

$$= (x-18)(p-3) \div 3$$

7(a) Volume of figure (including cut out part) = $6\text{cm} \times 4\text{cm} \times 12\text{cm}$
 $= 288\text{cm}^3$

Area of cut out part = $\frac{1}{2} \times 4\text{cm} \times (12\text{cm} - 9\text{cm})$
 $= 36\text{cm}^2$

Volume of doorstopper = $288\text{cm}^3 - 36\text{cm}^3$
 $= 252\text{cm}^3$

7(b) $5\text{cm} \times 6\text{cm} = 30\text{cm}^2$ (slanted area)

$9\text{cm} \times 6\text{cm} = 54\text{cm}^2$ (topside area)

$12\text{cm} \times 6\text{cm} = 72\text{cm}^2$ (bottom side area)

2 trapezium area sides = $4\text{cm} \times (12\text{cm} + 9\text{cm}) = 84\text{cm}^2$

Back side area = $6\text{cm} \times 4\text{cm} = 24\text{cm}^2$

Total surface area = $30\text{cm}^2 + 54\text{cm}^2 + 72\text{cm}^2 + 84\text{cm}^2 + 24\text{cm}^2$
 $= 264\text{cm}^2$

Subject:

No:

Date:

$$8(a) \text{ sum of interior angle} = (n-2) \times 180^\circ$$

$$\text{pentagon sum of interior angle} = (5-2) \times 180^\circ$$

$$= 540^\circ$$

$$\text{interior angle of pentagon} = 540^\circ \div 5$$

$$= 108^\circ$$

$$\text{exterior angle of pentagon} = 180^\circ - 108^\circ$$

$$= 72^\circ$$

$$\text{interior angle of } n\text{-sided polygon} = 72^\circ + 78^\circ$$

$$= 150^\circ$$

$$\text{interior angle of polygon} = \frac{(n-2) \times 180^\circ}{n}$$

$$= \frac{180n^\circ - 360^\circ}{n}$$

$$\frac{150^\circ}{1} = \frac{180n^\circ - 360^\circ}{n}$$

$$150n^\circ = 180n^\circ - 360^\circ$$

$$150n^\circ - 180n^\circ = -360^\circ$$

$$-30n^\circ = -360^\circ$$

$$-n^\circ = -12$$

$$n = 12 \quad \#$$

$$8(b) \text{ i) } 119 \text{ km} \div 70 \text{ km/h} = 1.7 \text{ h}$$

$$= 1 \text{ h } 42 \text{ mins}$$

$$\text{ii) } 119 \text{ km} \div (70 \text{ km} + x \text{ km/h}) = \text{total time taken}$$

$$\therefore \text{Time taken} = 119 \text{ km} \div (70 \text{ km} + x \text{ km/h}) \quad \#$$

$$\text{iii) } 119 \text{ km} \div (70 \text{ km} + x \text{ km/h}) \leq 1 \text{ hour } 20 \text{ mins}$$

$$x \geq 19.25$$

$$\text{minimum integer value of } x = 20 \quad \#$$

