

Visit

FreeTestPaper.com

for more papers



CANDIDATE NAME

CLASS

--	--	--

INDEX NUMBER

--	--	--

MATHEMATICS

4048

Secondary 1 Express

6 October 2016

Setter : Ms Pang Hui Chin

2 hours

Vetter : Mr Bennett Lim

Moderator: Mrs Sabrina Phang

Additional Materials: Nil

READ THESE INSTRUCTIONS FIRST

Write your name, register number and class on all the work you hand in.

Write in dark blue or black pen on both sides of the paper.

You may use an HB pencil for any diagrams or graphs.

Do not use staples, paper clips, glue or correction fluid.

Answer **all** questions in the question booklet.

If working is needed for any question it must be shown with the answer.

Omission of essential working will result in loss of marks.

The use of an approved scientific calculator is expected, where appropriate.

If the degree of accuracy is not specified in the question, and if the answer is not exact, give the answer to three significant figures. Give answers in degrees to one decimal place.

For π , use either your calculator value unless the question requires the answer in terms of π .

At the end of the examination, fasten all your work securely together.

The number of marks is given in brackets [] at the end of each question or part question.

The total number of marks for this paper is **80**.

Errors	Qn No.	Errors	Qn No.
Accuracy		Graphs	
Brackets		Geometry	
Fractions		Diagram	
Units		Others	

For Examiner's Use
80

Parent's/Guardian's Signature:

Section A (40 marks)

Answer **all** the questions in this section.

- 1 (a) Solve $-24 > 3x$.

Answer (a) [1]

- (b) Hence, state the largest integer that satisfies the inequality.

Answer (b) [1]

- 2 Given that $p:q = 5:4$ and $q:r = 3:7$, find $p:r$.

Answer : [2]

- 3 Express, correct to 3 significant figures,

- (a) 0.02496,

Answer (a) [1]

- (b) 32047.

Answer (b) [1]

- 4 From the following set of numbers

$$\frac{22}{7}, 1, 0, \sqrt{5}, -3, -\frac{2}{9}, \pi, 4.\dot{7}, 13,$$

write down

- (a) all the prime numbers,

Answer (a) [1]

- (b) all the irrational numbers,

Answer (b) [1]

- (c) all the whole numbers.

Answer (c) [1]

- 5 In a computer game, players gain points by capturing the game's characters which appear at various time intervals.

Character *A* appears every 28 minutes, character *B* appears every 48 minutes and character *C* appears every 120 minutes.

Ryan started playing the game at 8 am on Monday and all three characters appeared together. When will all three characters next appear together again?

Answer [3]

[Turn over

6 Alex bought a laptop in May. During an IT fair in August, he noticed that the price of the same laptop dropped by 16% to \$2016.

(a) Calculate the original price of the laptop.

Answer (a) \$ [1]

(b) The salesman at the fair told Alex that the price, \$2016, would be increased by 18% after the event. Alex thinks that the new price would be more than his original purchase price.

Do you think Alex is correct? Explain your answer with calculations.

.....
.....
..... [2]

7 Derek started running at an average speed of 15 km/h for 20 minutes. He took a rest of 10 minutes before running another 10 km in 50 minutes.

Calculate Derek's average speed for his entire journey.

Answer km/h [3]

8 Solve $\frac{3x-7}{3} - \frac{2x+3}{6} = -2$.

Answer $x = \dots\dots\dots$ [3]

[Turn over

- 9 The latest computer costs \$2490. George purchased it on hire purchase according to the following terms for the price:

A deposit of 30% and the remaining to be paid in monthly instalments over 2 years at a simple interest rate of 3.5% per annum.

- (a) Find the amount that George has to pay every month.

- (b) Find the total amount that George has to pay for the computer. *Answer* [2]

Answer \$ [1]

- 10 Meredith and her family travelled to Rio de Janeiro in Brazil to watch the 2016 Summer Olympic Games. The rate of exchange between Brazilian Real and Singapore dollars (S\$) is S\$1 = 2.37 Real.
- (a) The family exchanged S\$7650 and spent 8240 Real.
Calculate the remaining amount of money, in Real.

Answer (a) Real [2]

- (b) Meredith travelled to the United States of America without her family after the games ended.
She exchanged 6000 Real to US dollars (US\$). The rate of exchange between US\$ and Real is US\$1 = 3.26 Real.
Calculate the amount of money, in US\$, that Meredith has.

Answer (b) US\$ [1]

- 11 The graph shows the amount of money a company spent on training programmes for its employees in the first 4 months of 2016.

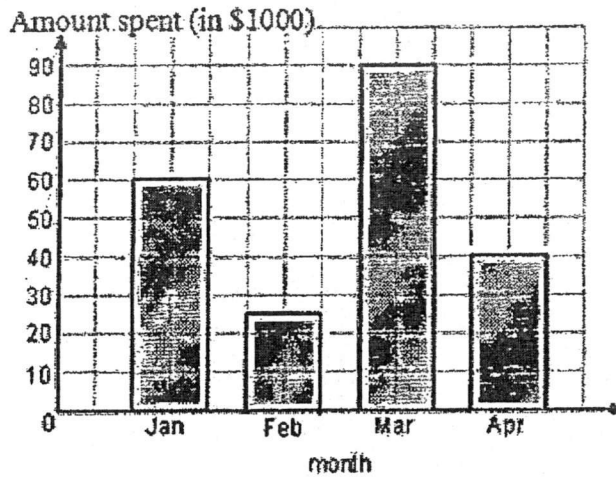

- (a) Calculate the amount of money spent on training programmes in the four months.

Answer (a) \$ [1]

- (b) Calculate the percentage decrease in the amount spent in training programmes from January to February.

Answer (b)% [1]

- (c) If the information is illustrated on a pie chart, find the angle of the sector for April, giving your answer correct to one decimal place.

Answer (c)° [2]

12 (a) Factorise $8x^2y^3 - 4xy^5$ completely.

Answer (a) [1]

(b) Factorise $3a(2a - b) + 5(b - 2a)$.

Answer (b) [1]

(c) Expand and simplify $3[-22x - 2x(15 - 18y)]$.

Answer (c) [2]

[Turn over

- 13 The diagram shows part of a regular polygon $ABCDE\dots$ and a regular pentagon $DEFGH$. It is given that $\angle BAC = 20^\circ$.

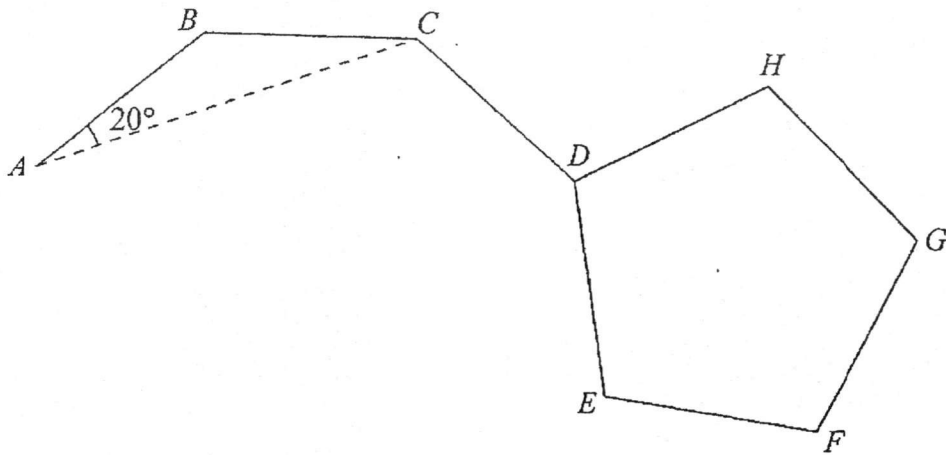

Calculate

- (a) the exterior angle of the polygon $ABCDE\dots$, stating your reasons clearly,

Answer (a) $^\circ$ [2]

- (b) the number of sides of the polygon $ABCDE\dots$, stating your reasons clearly,

Answer (b) [1]

- (c) $\angle CDH$.

Answer (c) $^\circ$ [2]

Section B (40 marks)

Answer all the questions in this section.

- 14 In the diagram, WX is parallel to YZ and WS is a straight line that intersects YZ at T .

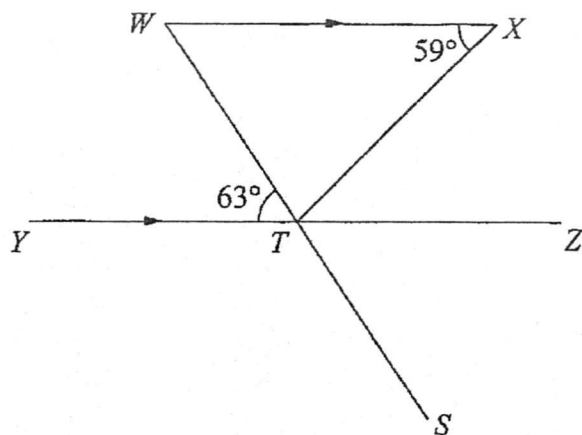

Given that $\angle WXT = 59^\circ$ and $\angle WTY = 63^\circ$, find $\angle XTS$. State your reasons clearly. [3]

- 15 $ABCD$ is a parallelogram such that $AB = (8x - 11)$ cm and $AD = (2x - 1)$ cm.
 PQR is a triangle such that $PQ = (6x - 3)$ cm, $QR = 2x$ cm and $PR = (4x + 3)$ cm.

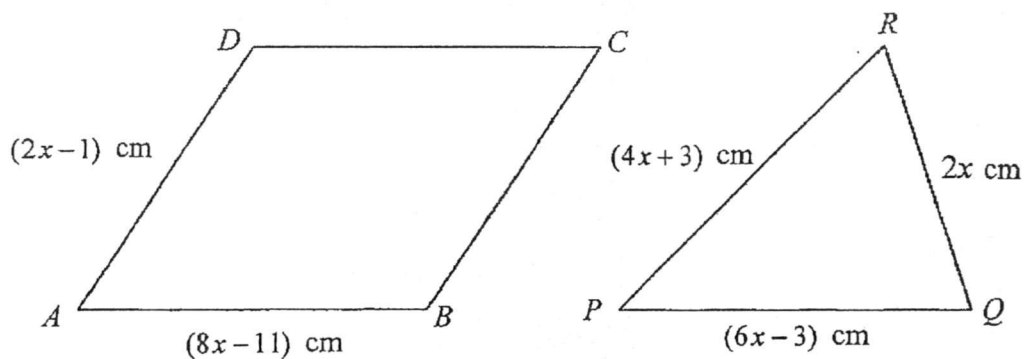

The perimeter of the parallelogram is equal to the perimeter of the triangle.

- (a) By forming an equation in x , show that $x = 3$. [2]
- (b) Given that the perpendicular from D to AB is $(3x - 5)$ cm, find the area of the parallelogram $ABCD$. [2]

- 16 In the diagram, $ABCD$ is a rhombus found in a kite $BCDE$. The diagonals CE and BD intersect each other at M .

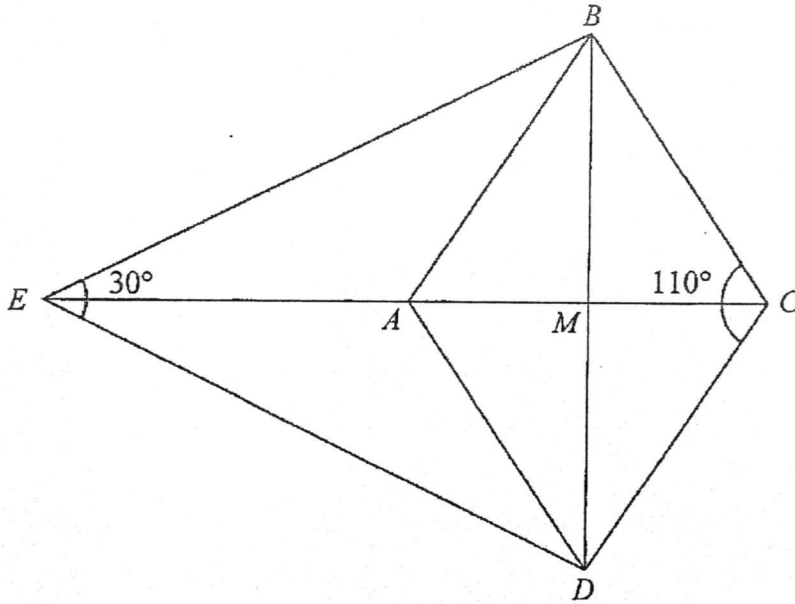

Given that $\angle BCD = 110^\circ$ and $\angle BED = 30^\circ$, stating your reasons clearly, find

- | | |
|--------------------|-----|
| (a) $\angle BAD$, | [1] |
| (b) $\angle BME$, | [1] |
| (c) $\angle ABE$. | [3] |

17 Isabelle made a series of diagram using dots and lines. The first three figures are as shown.

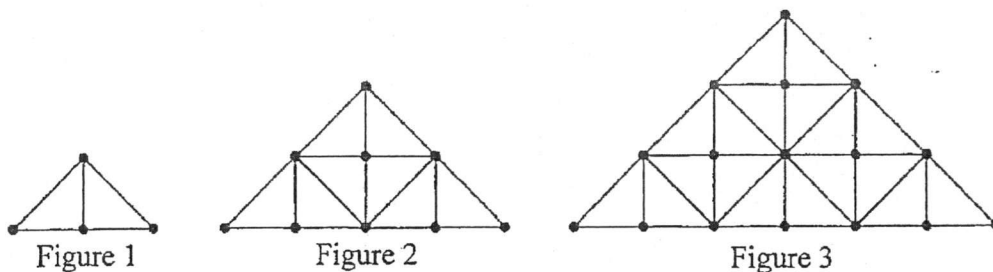

- (a) Draw Figure 4. [1]
- (b) The number of dots and the number of the smallest right-angled triangles formed to make each of the figures are shown in the table below. Complete the table below for the row of Figure 4. [1]

Figure	Number of Dots	Number of Smallest Right-Angled Triangles
1	4	2
2	9	8
3	16	18
4		

- (c) (i) Form an expression in n , for the number of dots for Figure n . [1]
- (ii) Hence, find the number of dots for Figure 37. [1]
- (d) Form an expression in n , for the number of the smallest right-angled triangles formed for Figure n . [1]

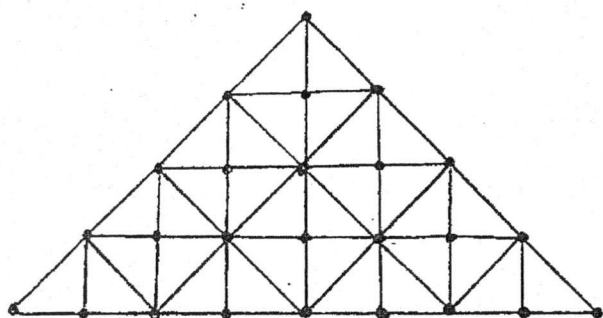

- 18 Construct a quadrilateral $PQRS$ such that $PQ = 10.5$ cm, $QR = 5$ cm, $PS = 8$ cm, $SR = 5.3$ cm and $\angle PQR = 70^\circ$. [2]
- (a) Construct the perpendicular bisector of QR . [1]
- (b) The point X lies on the perpendicular bisector of QR and is equidistant from RS and PS . By constructing a suitable line, find and label the point X . [2]
- (c) Hence, measure and state the value of $\angle RSX$. [1]

- 19 The diagram below shows a cage for a pet hamster that comprises a trapezium-base prism $ABCDEFGH$ with AB parallel to DC and an open cylindrical tunnel. $AB = 43$ cm, $BC = 24$ cm, $CD = 50$ cm, $AD = 25$ cm and $AE = 20$ cm. $\angle ABC = 90^\circ$ and $\angle EFG = 90^\circ$.

The cylindrical tunnel is 35 cm long.

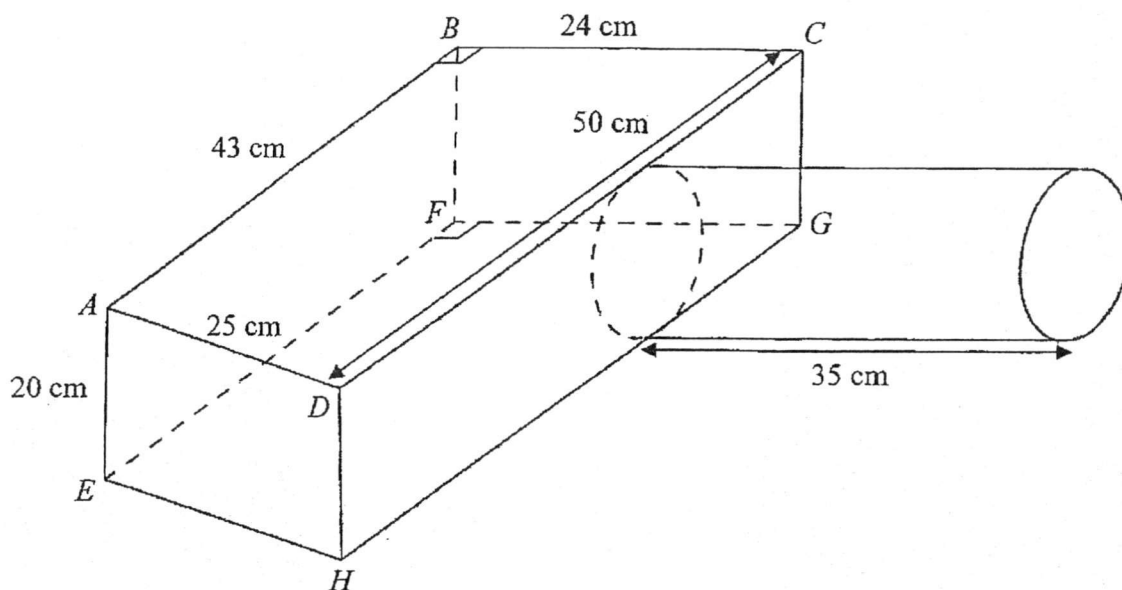

Take $\pi = \frac{22}{7}$ in your calculations.

- (a) Given that the curved surface area of the cylindrical tunnel is 2200 cm², show that the radius of the cylindrical tunnel is approximately 10 cm. [1]

Hence, calculate

- (b) the total volume of the cage, in l , [3]
 (c) the total surface area of the cage, in m², [4]

Write your answer for the whole of question 19 on the next page.

Write your answer for the whole of question 19 on this page.

20 Answer the whole of this question on a sheet of graph paper.

Two companies are recruiting students to sell a new energy drink, at \$4 per bottle, at the Food Fair during the December school holidays.

Drinks Paradise

Calling out to all students!
Earn \$7 / hour and a
commission of 10% on your
total sales made!

Call us!

Yummy Palace

Are you an 'N'/'O'/'A'
level graduate looking for a
part-time job?
Earn \$10 / hour.

Join us now!

Christina is committed to working 8 hours a day.

The tables below show Christina's possible income for one day, \$ y , when she sells x bottles of energy drinks if she works for the respective companies.

Drinks Paradise:

Number of bottles of energy drinks, x bottles	0	80	120
Income, \$ y	56	p	104

Yummy Palace:

Number of bottles of energy drinks, x bottles	0	80	120
Income, \$ y	80	80	80

- (a) Show that $p = 88$. [1]
- (b) (i) Using a scale of 2 cm to represent 20 bottles on the horizontal axis and 2 cm to represent \$10 on the vertical axis, draw the graph of \$ y against x bottles for Drinks Paradise. [3]
- (ii) Similarly, on the same axes, draw the graph for Yummy Palace. [1]
- (c) State the equation of the line for Yummy Palace. [1]
- (d) Find
- (i) the gradient of the line, [1]
- (ii) the y -intercept of the line. [1]
- (e) Using both the graphs, determine the minimum number of bottles of energy drinks that Christina needs to sell so that Drinks Paradise would be paying her more than Yummy Palace. [1]



XINMIN SECONDARY SCHOOL

新民中学

SEKOLAH MENENGAH XINMIN
End-of-Year Examination 2016

CANDIDATE NAME

Marking Scheme

CLASS

--	--	--

INDEX NUMBER

--	--

MATHEMATICS

4048

Secondary 1 Express

6 October 2016

Setter : Ms Pang Hui Chin

2 hours

Vetter : Mr Bennett Lim

Moderator: Mrs Sabrina Phang

Additional Materials: Nil

READ THESE INSTRUCTIONS FIRST

Write your name, register number and class on all the work you hand in.
Write in dark blue or black pen on both sides of the paper.
You may use an HB pencil for any diagrams or graphs.
Do not use staples, paper clips, glue or correction fluid.

Answer **all** questions in the question booklet.

If working is needed for any question it must be shown with the answer.

Omission of essential working will result in loss of marks.

The use of an approved scientific calculator is expected, where appropriate.

If the degree of accuracy is not specified in the question, and if the answer is not exact, give the answer to three significant figures. Give answers in degrees to one decimal place.

For π , use either your calculator value unless the question requires the answer in terms of π .

At the end of the examination, fasten all your work securely together.

The number of marks is given in brackets [] at the end of each question or part question.

The total number of marks for this paper is **80**.

Errors	Qn No.	Errors	Qn No.
Accuracy		Graphs	
Brackets		Geometry	
Fractions		Diagram	
Units		Others	

For Examiner's Use

Parent's/Guardian's Signature:

Section A (40 marks)

Answer all the questions in this section.

- 1 (a) Solve $-24 > 3x$.

$$-24 > 3x$$

$$\frac{-24}{3} > x$$

$$-8 > x$$

Answer (a) $-8 > x$ or $x < -8$. ^{either B1} [1]

- (b) Hence, state the largest integer that satisfies the inequality.

Answer (b) -9 — B1 [1]

- 2 Given that $p:q=5:4$ and $q:r=3:7$, find $p:r$.

$$p:q = 5:4 \\ = \underline{15:12}$$

$$q:r = 3:7 \\ = \underline{12:28} \text{ — M1 for both}$$

$$\therefore p:r = 15:28$$

Answer 15 28 — A1 [2]

- 3 Express, correct to 3 significant figures,

(a) 0.02496,

Answer (a) 0.0250 — B1 [1]

(b) 32047.

Answer (b) 32000 — B1 [1]

- 4 From the following set of numbers

$$\frac{22}{7}, 1, 0, \sqrt{5}, -3, -\frac{2}{9}, \pi, 4.\dot{7}, 13,$$

write down

- (a) all the prime numbers,

Answer (a) 13 -B1 [1]

- (b) all the irrational numbers,

Answer (b) $\sqrt{5}, \pi$ -B1 [1]

- (c) all the whole numbers.

Answer (c) 0, 1, 13 -B1 [1]

- 5 In a computer game, players gain points by capturing the game's characters which appear at various time intervals.

Character A appears every 28 minutes, character B appears every 48 minutes and character C appears every 120 minutes.

Ryan started playing the game at 8 am on Monday and all three characters appeared together. When will all three characters next appear together again?

$$\left. \begin{aligned} 28 &= 2^2 \times 7 \\ 48 &= 2^4 \times 3 \\ 120 &= 2^3 \times 3 \times 5 \end{aligned} \right\} M1$$

$$LCM = 2^4 \times 3 \times 5 \times 7 \rightarrow M1$$

$$= 1680 \text{ minutes}$$

$$= 28h$$

$$\therefore 8 \text{ am, Monday} + 28h = 12 \text{ pm, Tuesday}$$

2	28	48	120
2	14	24	60
2	7	12	30
3	7	6	15
	7	2	5

Answer 12pm, Tuesday -A1 [3]

[Turn over

- 6 Alex bought a laptop in May. During an IT fair in August, he noticed that the price of the same laptop dropped by 16% to \$2016.

(a) Calculate the original price of the laptop.

$$\begin{aligned} \text{original price} &= \frac{100}{84} \times \$2016 & \text{or} & \frac{\$2016}{84\%} \times 100\% \\ &= \$2400 & & = \$2400 \end{aligned}$$

Answer (a) \$ 2400 — A1 [1]

- (b) The salesman at the fair told Alex that the price, \$2016, would be increased by 18% after the event. Alex thinks that the new price would be more than his original purchase price.

Do you think Alex is correct? Explain your answer with calculations.

$$\frac{118}{100} \times \$2016 = \$2378.88 \text{ — M1}$$

No, Alex is wrong as the new price is \$2378.88, which is
lesser than \$2400. — A1

[2]

- 7 Derek started running at an average speed of 15 km/h for 20 minutes. He took a rest of 10 minutes before running another 10 km in 50 minutes. Calculate Derek's average speed for his entire journey.

$$\begin{aligned} \text{total distance} &= \left(15 \times \frac{20}{60}\right) + 10 \text{ — M1} \\ &= 5 + 10 \\ &= 15 \text{ km.} \end{aligned}$$

$$\begin{aligned} \text{total time} &= 20 + 10 + 50 \\ &= 80 \text{ min} \\ &= 1\frac{1}{3} \text{ h.} \end{aligned}$$

$$\begin{aligned} \therefore \text{average speed} &= \frac{15}{1\frac{1}{3}} \text{ — M1} \\ &= 11.25 \text{ km/h} \end{aligned}$$

Answer 11.25 or $11\frac{1}{4}$ — A1 km/h [3]

8 Solve $\frac{3x-7}{3} - \frac{2x+3}{6} = -2.$

$$\frac{3x-7}{3} - \frac{2x+3}{6} = -2.$$

$$\frac{2(3x-7) - (2x+3)}{6} = -2. \quad \text{--- M1: common denominator}$$

$$\frac{6x - 14 - 2x - 3}{6} = -2.$$

$$4x - 17 = -12 \quad \text{--- M1: simplifying}$$

$$4x = -12 + 17$$

$$= 5$$

$$x = \frac{5}{4}$$

$$= 1\frac{1}{4}.$$

Alternatively,

$$2(3x-7) - (2x+3) = -12 \quad \text{--- M1: 'remaining' denominator}$$

$$6x - 14 - 2x - 3 = -12$$

$$4x - 17 = -12 \quad \text{--- M1: simplifying}$$

$$4x = 5$$

$$x = 1\frac{1}{4}.$$

Answer $x = \dots\dots\dots 1\frac{1}{4} \text{ --- A1} \quad [3]$

[Turn over

- 9 The latest computer costs \$2490. George purchased it on hire purchase according to the following terms for the price:

A deposit of 30% and the remaining to be paid in monthly instalments over 2 years at a simple interest rate of 3.5% per annum.

- (a) Find the amount that George has to pay every month.

$$\begin{aligned} \text{amount remaining} &= \frac{70}{100} \times \$2490 \\ &= \$1743. \end{aligned}$$

$$\begin{aligned} \text{interest amount} &= \frac{3.5}{100} \times \$1743 \times 2 \text{ --- B1} \\ &= \$122.01. \end{aligned}$$

Alternatively,

$$\begin{aligned} \text{interest amount} &= \frac{70}{100} \times \$2490 \times \frac{3.5}{100} \times 2 \text{ --- B1} \\ &= \$122.01. \end{aligned}$$

$$\begin{aligned} \text{monthly instalment} &= (\$1743 + \$122.01) \div 24 \\ &= \$77.71 \text{ (2d.p.)} \end{aligned}$$

Answer \$ 77.71 --- A1 [2]

- (b) Find the total amount that George has to pay for the computer.

$$\begin{aligned} \text{total amount} &= \$2490 + \$122.01 \\ &= \$2612.01 \end{aligned}$$

Alternatively,

$$\begin{aligned} \text{total amount} &= \left(\frac{70}{100} \times \$2490 \times \frac{3.5}{100} \times 2 \right) + \$2490 \\ &= \$2612.01. \end{aligned}$$

Answer \$ 2612.01 --- A1 [1]

10 Meredith and her family travelled to Rio de Janeiro in Brazil to watch the 2016 Summer Olympic Games. The rate of exchange between Brazilian Real and Singapore dollars (S\$) is S\$1 = 2.37 Real.

- (a) The family exchanged S\$7650 and spent 8240 Real.
Calculate the remaining amount of money, in Real.

$$\begin{aligned} \text{amount of money left} &= \text{S\$7650} - 8240 \text{ Real} \\ &= (7650 \times 2.37) \text{ Real} - 8240 \text{ Real} \quad \text{--- M1} \\ &= 9890.50 \text{ Real.} \end{aligned}$$

Answer (a) $9890.50 - \text{A1}$ Real [2]

- (b) Meredith travelled to the United States of America without her family after the games ended.
She exchanged 6000 Real to US dollars (US\$). The rate of exchange between US\$ and Real is US\$1 = 3.26 Real.
Calculate the amount of money, in US\$, that Meredith has.

$$\begin{aligned} \text{amount of money} &= \frac{6000}{3.26} \\ &\approx \text{US\$ } 1840.49 \text{ (2dp)} \end{aligned}$$

Answer (b) US\$ $1840.49 - \text{A1}$ [1]

- 11 The graph shows the amount of money a company spent on training programmes for its employees in the first 4 months of 2016.

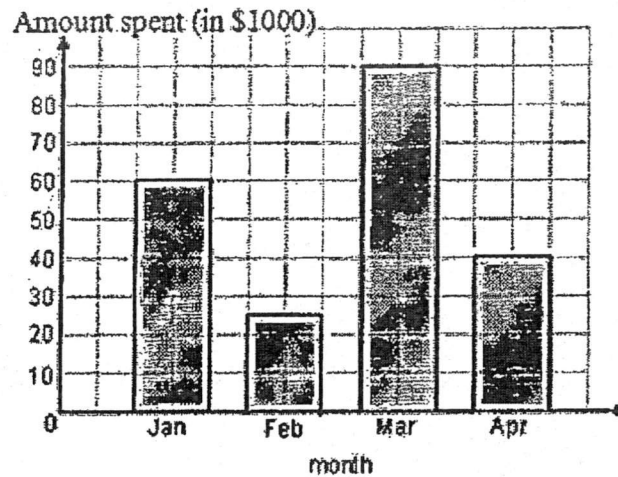

- (a) Calculate the amount of money spent on training programmes in the four months.

$$60000 + 25000 + 90000 + 40000 = 215000$$

Answer (a) \$ 215 000 - B1 [1]

- (b) Calculate the percentage decrease in the amount spent in training programmes from January to February.

$$\begin{aligned} \% \text{ decrease} &= \frac{60000 - 25000}{60000} \times 100\% \\ &= 58\frac{1}{3}\% \end{aligned}$$

Answer (b) 58 $\frac{1}{3}$ - B1 % [1]

- (c) If the information is illustrated on a pie chart, find the angle of the sector for April, giving your answer correct to one decimal place.

$$\begin{aligned} \angle \text{ for April} &= \frac{40000}{215000} \times 360^\circ \text{ --- M1} \\ &= 67.0^\circ \text{ (1dp)} \end{aligned}$$

Answer (c) 67.0 - A1 ° [2]

- 12 (a) Factorise $8x^2y^3 - 4xy^5$ completely.

$$\begin{aligned} & 8x^2y^3 - 4xy^5 \\ &= 4xy^3(2x - y^2) \end{aligned}$$

Answer (a) $4xy^3(2x - y^2) - B1$ [1]

- (b) Factorise $3a(2a - b) + 5(b - 2a)$.

$$\begin{aligned} & 3a(2a - b) + 5(b - 2a) \\ &= 3a(2a - b) - 5(2a - b) \\ &= (2a - b)(3a - 5) \end{aligned}$$

Answer (b) $(2a - b)(3a - 5) - B1$ [1]

- (c) Expand and simplify $3[-22x - 2x(15 - 18y)]$.

$$\begin{aligned} & 3[-22x - 2x(15 - 18y)] \\ &= 3[-22x - 30x + 36xy] \text{ --- M1: expansion} \\ &= 3(-52x + 36xy) \\ &= -156x + 108xy \end{aligned}$$

Answer (c) $-156x + 108xy - A1$ [2]

[Turn over

- 13 The diagram shows part of a regular polygon $ABCDE\dots$ and a regular pentagon $DEFGH$. It is given that $\angle BAC = 20^\circ$.

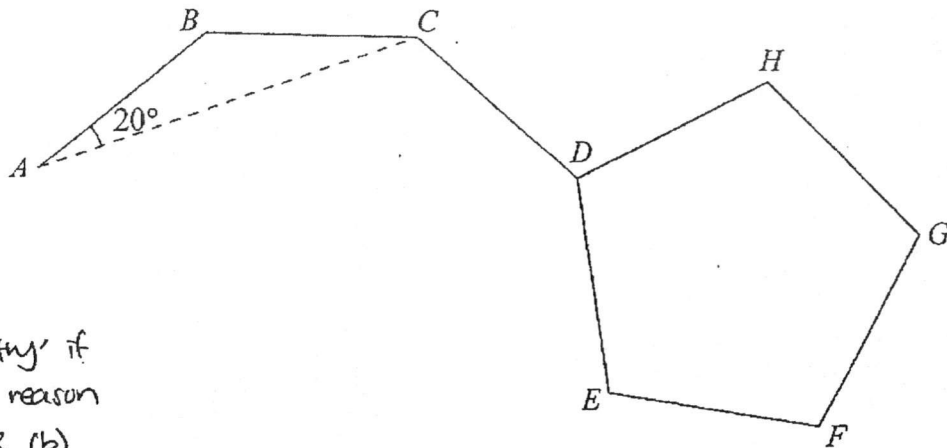

*penalise 'geometry' if missing/wrong reason given for (a) & (b)

Calculate

- (a) the exterior angle of the polygon $ABCDE\dots$, stating your reasons clearly,

$$\begin{aligned} \angle BCA &= 20^\circ \text{ (base } \angle\text{s of isos. } \triangle) \text{ - M1} \\ \text{ext. } \angle &= 20^\circ + 20^\circ \\ &= 40^\circ \text{ (ext. } \angle \text{ of } \triangle) \end{aligned}$$

Alternatively,

$$\begin{aligned} \angle BCA &= 20^\circ \text{ (base } \angle\text{s of isos. } \triangle) \text{ - M1} \\ \angle ABC &= 180^\circ - 20^\circ - 20^\circ \\ &= 140^\circ \text{ (} \angle \text{ sum of } \triangle) \\ \text{ext. } \angle &= 180^\circ - 140^\circ = 40^\circ \text{ (adj. } \angle\text{s on a str. line)} \end{aligned}$$

Answer (a) 40 - A1 [2]

- (b) the number of sides of the polygon $ABCDE\dots$, stating your reasons clearly,

$$\begin{aligned} \text{no. of sides} &= \frac{360^\circ}{4} \\ &= 9 \text{ sides.} \end{aligned}$$

Alternatively,

$$\begin{aligned} \text{int. } \angle &= \frac{(n-2) \times 180^\circ}{n} \\ 140^\circ \times n &= 180^\circ \times n - 360^\circ \\ 40^\circ \times n &= 360^\circ \\ n &= 9 \end{aligned}$$

Answer (b) 9 - A1 [1]

- (c) $\angle CDH$.

$$\begin{aligned} \angle HDE &= \frac{(5-2) \times 180^\circ}{5} \\ &= 108^\circ \text{ - M1} \end{aligned}$$

$$\angle CDE = 140^\circ$$

$$\begin{aligned} \therefore \angle CDH &= 360^\circ - 108^\circ - 140^\circ \\ &= 112^\circ \text{ (} \angle\text{s at a pt.)} \end{aligned}$$

Alternatively,

$$\begin{aligned} \text{ext. } \angle \text{ of pentagon} &= \frac{360^\circ}{5} \\ &= 72^\circ \text{ - M1} \end{aligned}$$

$$\begin{aligned} \angle CDH &= 40^\circ + 72^\circ \\ &= 112^\circ \end{aligned}$$

Answer (c) 112 - A1 [2]

Section B (40 marks)

Answer all the questions in this section.

- 14 In the diagram, WX is parallel to YZ and WS is a straight line that intersects YZ at T .

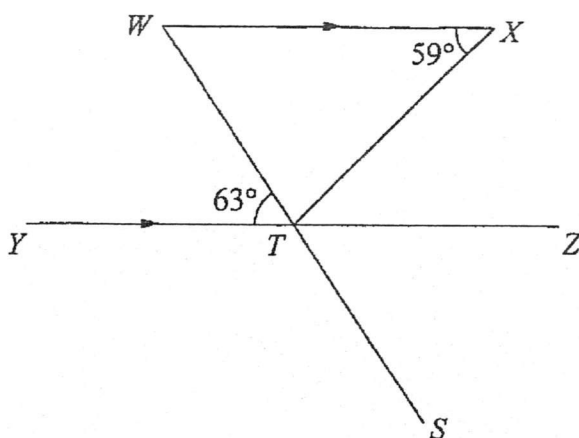

*penalise 'geometry' if
wrong/missing reason.

Given that $\angle WXT = 59^\circ$ and $\angle WTY = 63^\circ$, find $\angle XTS$. State your reasons clearly. [3]

$$\angle XTZ = 59^\circ \text{ (alt. } \angle\text{s, // lines) — M1}$$

$$\angle STZ = 63^\circ \text{ (vert. opp. } \angle\text{s) — M1}$$

$$\angle XTS = 59^\circ + 63^\circ$$

$$= 122^\circ \text{ — A1}$$

Alternatively,

$$\angle XTZ = 59^\circ \text{ (alt. } \angle\text{s, // lines) — M1}$$

$$\angle WTX = 180^\circ - 59^\circ - 63^\circ$$

$$= 58^\circ \text{ (adj. } \angle\text{s on a str. line) } \left. \vphantom{\begin{matrix} \angle WTX \\ \angle STZ \end{matrix}} \right\} \text{M1}$$

$$\angle STZ = 180^\circ - 59^\circ - 58^\circ$$

$$= 63^\circ \text{ (adj. } \angle\text{s on a str. line)}$$

$$\therefore \angle XTS = 63^\circ + 59^\circ$$

$$= 122^\circ \text{ — A1}$$

- 15 $ABCD$ is a parallelogram such that $AB = (8x - 11)$ cm and $AD = (2x - 1)$ cm.
 PQR is a triangle such that $PQ = (6x - 3)$ cm, $QR = 2x$ cm and $PR = (4x + 3)$ cm.

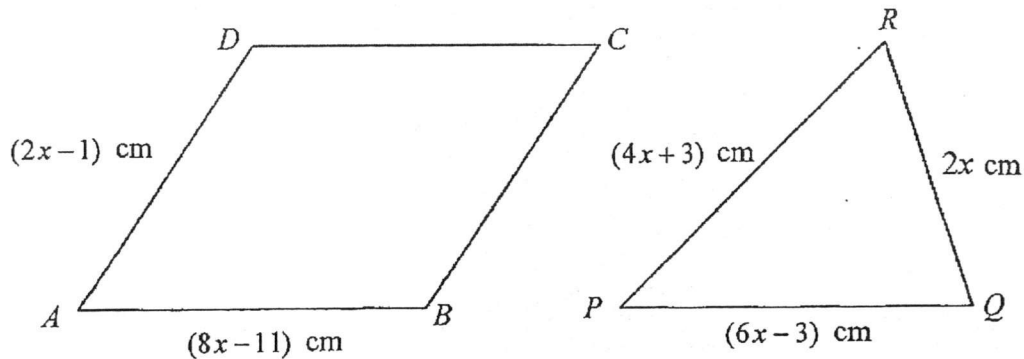

The perimeter of the parallelogram is equal to the perimeter of the triangle.

- (a) By forming an equation in x , show that $x = 3$. [2]
 (b) Given that the perpendicular from D to AB is $(3x - 5)$ cm, find the area of the parallelogram $ABCD$. [2]

$$(a) \quad 2[2x - 1 + 8x - 11] = (4x + 3) + (6x - 3) + 2x \quad \text{--- M1: form equation.}$$

$$2(10x - 12) = 12x$$

$$20x - 24 = 12x$$

$$20x - 12x = 24$$

$$8x = 24$$

$$x = 3 \text{ (shown). --- A1}$$

$$(b) \text{ area of parallelogram} = (8x - 11) \times (3x - 5)$$

$$= [8(3) - 11] \times [3(3) - 5] \quad \text{--- M1: substitution}$$

$$= 13 \times 4$$

$$= 52 \text{ cm}^2 \text{ --- A1}$$

- 16 In the diagram, $ABCD$ is a rhombus found in a kite $BCDE$. The diagonals CE and BD intersect each other at M .

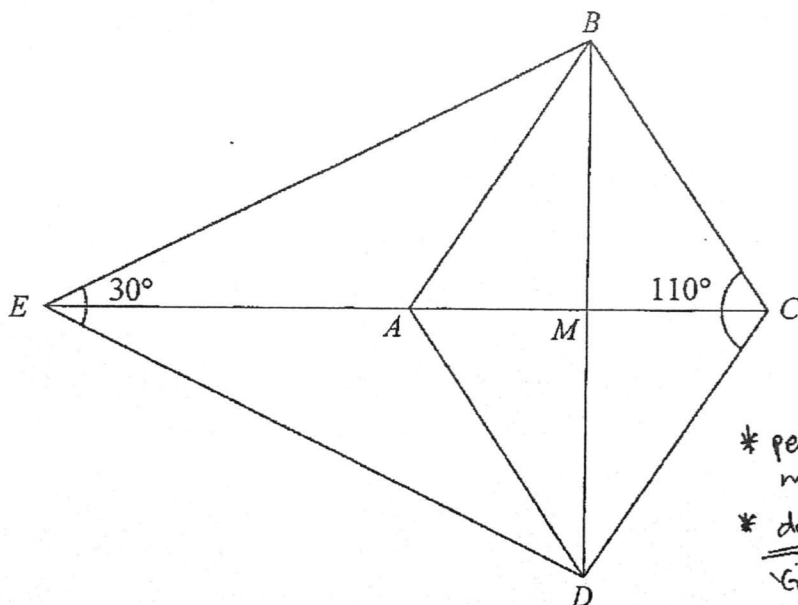

* penalise under 'Geometry' if wrong/missing reasons.
* do not penalise under 'Geometry' if underlined one are wrong/missing.

Given that $\angle BCD = 110^\circ$ and $\angle BED = 30^\circ$, stating your reasons clearly, find

- (a) $\angle BAD$, [1]
(b) $\angle BME$, [1]
(c) $\angle ABE$. [3]

(a) $\angle BAD = 110^\circ$ (opp. \angle s of rhombus) — B1

Alternatively,

$$\begin{aligned} \angle ABC &= 180^\circ - 110^\circ \\ &= 70^\circ \text{ (int. \angle s, // lines)} \\ \angle BAD &= 180^\circ - 70^\circ \\ &\quad - 110^\circ \text{ (int. \angle s, // lines)} \end{aligned} \quad \left. \vphantom{\begin{aligned} \angle ABC \\ \angle BAD \end{aligned}} \right\} \text{B1}$$

(b) $\angle BME = 90^\circ$ (diagonals of kite/rhombus) — B1

(c) $\angle BEA = 30^\circ \div 2$
 $= 15^\circ$ (bisected \angle) — M1

$\angle MBE = 180^\circ - 90^\circ - 15^\circ$
 $= 75^\circ$ (\angle sum of Δ)

$\angle ABM = \frac{180^\circ - 110^\circ}{2}$
 $= 35^\circ$ (base \angle s of (isos. Δ)) — M1

$\angle ABE = 75^\circ - 35^\circ$
 $= 40^\circ$ — A1

Alternatively,

$\angle CBE = \frac{360^\circ - 30^\circ - 110^\circ}{2}$
 $= 110^\circ$ (\angle sum of quad.) — M1

$\angle ABC = 180^\circ - 110^\circ$
 $= 70^\circ$ (int. \angle s, // lines) — M1

$\angle ABE = 110^\circ - 70^\circ$
 $= 40^\circ$ — A1

17 Isabelle made a series of diagram using dots and lines. The first three figures are as shown.

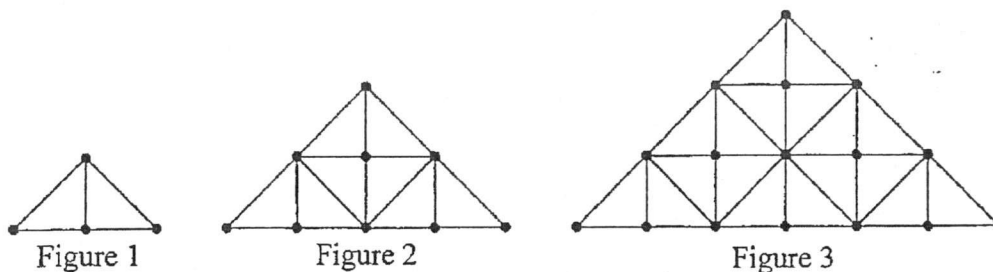

- (a) Draw Figure 4. [1]
- (b) The number of dots and the number of the smallest right-angled triangles formed to make each of the figures are shown in the table below. Complete the table below for the row of Figure 4. [1]

Figure	Number of Dots	Number of Smallest Right-Angled Triangles
1	4	2
2	9	8
3	16	18
4	25	32

- (c) (i) Form an expression in n , for the number of dots for Figure n . [1]
- (ii) Hence, find the number of dots for Figure 37. [1]
- (d) Form an expression in n , for the number of the smallest right-angled triangles formed for Figure n . [1]

(a)

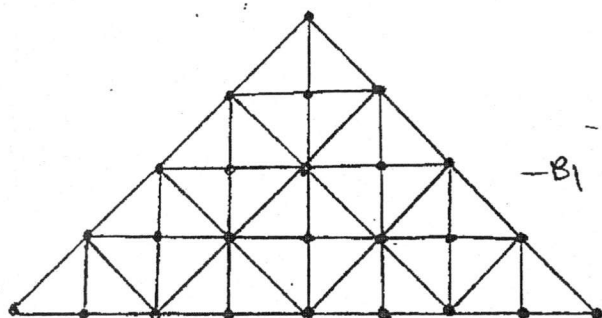

(c)(i) no. of dots = $(n+1)^2$ — B1
 (ii) no. of dots = $(37+1)^2$
 = 1444 — B1 (allow ecf)

(d) no. of smallest right-angled Δ
 = $2n^2$ — B1

- 18 Construct a quadrilateral $PQRS$ such that $PQ = 10.5$ cm, $QR = 5$ cm, $PS = 8$ cm, $SR = 5.3$ cm and $\angle PQR = 70^\circ$. [2]
- (a) Construct the perpendicular bisector of QR . [1]
- (b) The point X lies on the perpendicular bisector of QR and is equidistant from RS and PS . By constructing a suitable line, find and label the point X . [2]
- (c) Hence, measure and state the value of $\angle RSX$. [1]

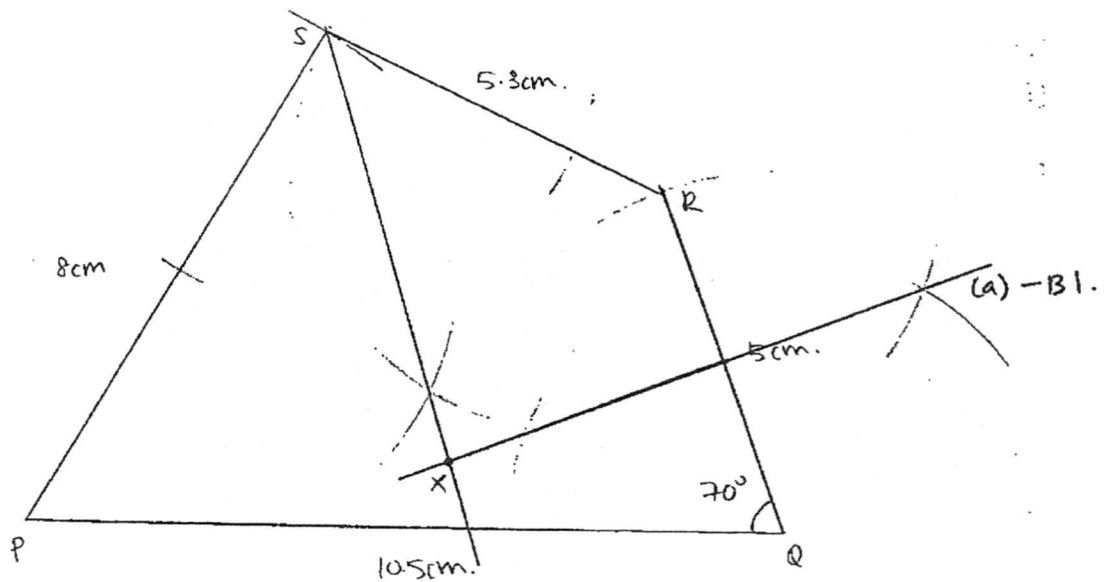

- (b) B1 - drawing angle bisector of $\angle PSR$.
B1 - locating X and labelling.

- (c) $\angle RSX = 48^\circ \pm 0.1^\circ$ - B1

- 19 The diagram below shows a cage for a pet hamster that comprises a trapezium-base prism $ABCDEFGH$ with AB parallel to DC and an open cylindrical tunnel. $AB = 43$ cm, $BC = 24$ cm, $CD = 50$ cm, $AD = 25$ cm and $AE = 20$ cm. $\angle ABC = 90^\circ$ and $\angle EFG = 90^\circ$. The cylindrical tunnel is 35 cm long.

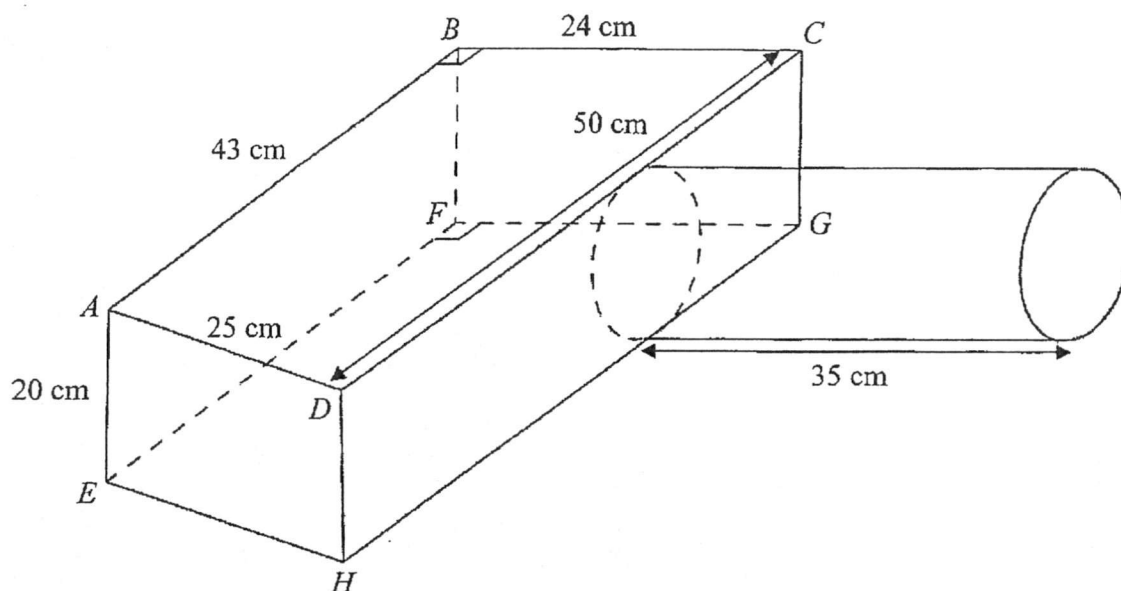

Take $\pi = \frac{22}{7}$ in your calculations.

- (a) Given that the curved surface area of the cylindrical tunnel is 2200 cm^2 , show that the radius of the cylindrical tunnel is approximately 10 cm. [1]
- Hence, calculate
- (b) the total volume of the cage, in l , [3]
- (c) the total surface area of the cage, in m^2 , [4]

Write your answer for the whole of question 19 on the next page.

Write your answer for the whole of question 19 on this page.

(a) Let the radius be r cm,

$$\text{curved surface area} = 2\pi r (35)$$

$$2200 = 2 \left(\frac{22}{7}\right) r (35)$$

$$r = \frac{2200}{2 \left(\frac{22}{7}\right) (35)} \left. \vphantom{r} \right\} \text{A1}$$

$$= 10 \text{ cm.}$$

(b) total volume

$$= \left[\frac{1}{2} \times (50 + 43) \times 24 \right] \times 20 + \left[\left(\frac{22}{7}\right) (10)^2 (35) \right] - \text{M1} + \text{M1}$$

$$= 22320 + 11000$$

$$= 33320 \text{ cm}^3$$

$$= 33.32 \text{ l.} - \text{A1}$$

(c) total surface area

$$= \left\{ \left[\frac{1}{2} \times (50 + 43) \times 24 \right] \times 2 + (43 \times 20) + (50 \times 20) + (24 \times 20) + (25 \times 20) \right\} - \text{prism S.A.} \rightarrow \text{M1}$$

$$+ 2 \left(\frac{22}{7}\right) (10) (35) - \left(\frac{22}{7}\right) (10)^2 \left. \vphantom{+} \right\} \rightarrow \text{cylinder S.A.} \rightarrow \text{M1.}$$

$$= 5072 + 1885 \frac{5}{7}$$

$$= 6957 \frac{5}{7} \text{ cm}^2. - \text{M1}$$

$$1 \text{ cm} = \frac{1}{100} \text{ m}$$

$$1 \text{ cm}^2 = \left(\frac{1}{100}\right)^2 \text{ m}^2$$

$$= 0.0001 \text{ m}^2.$$

$$\therefore \text{total surface area} = 6957 \frac{5}{7} \times 0.0001$$

$$= \frac{3044}{4375} \text{ m}^2 \text{ or } \underline{0.696 \text{ m}^2} \text{ (3 sf.)} - \text{either A1}$$

20 Answer the whole of this question on a sheet of graph paper.

Two companies are recruiting students to sell a new energy drink, at \$4 per bottle, at the Food Fair during the December school holidays.

Drinks Paradise

Calling out to all students!
Earn \$7 / hour and a
commission of 10% on your
total sales made!

Call us!

Yummy Palace

Are you an 'N'/'O'/'A'
level graduate looking for a
part-time job?
Earn \$10 / hour.

Join us now!

Christina is committed to working 8 hours a day.

The tables below show Christina's possible income for one day, \$ y , when she sells x bottles of energy drinks if she works for the respective companies.

Drinks Paradise:

Number of bottles of energy drinks, x bottles	0	80	120
Income, \$ y	56	p	104

Yummy Palace:

Number of bottles of energy drinks, x bottles	0	80	120
Income, \$ y	80	80	80

- (a) Show that $p = 88$. [1]
- (b) (i) Using a scale of 2 cm to represent 20 bottles on the horizontal axis and 2 cm to represent \$10 on the vertical axis, draw the graph of \$ y against x bottles for Drinks Paradise. [3]
- (ii) Similarly, on the same axes, draw the graph for Yummy Palace. [1]
- (c) State the equation of the line for Yummy Palace. [1]
- (d) Find [1]
- (i) the gradient of the line, [1]
- (ii) the y -intercept of the line. [1]
- (e) Using both the graphs, determine the minimum number of bottles of energy drinks that Christina needs to sell so that Drinks Paradise would be paying her more than Yummy Palace. [1]

(b)(i) scale & axis — B1
plotted points — B1
line & label — B1

(b)(ii) line with label — B1

Name _____ Index No. _____

Subject _____ Class _____ Date _____

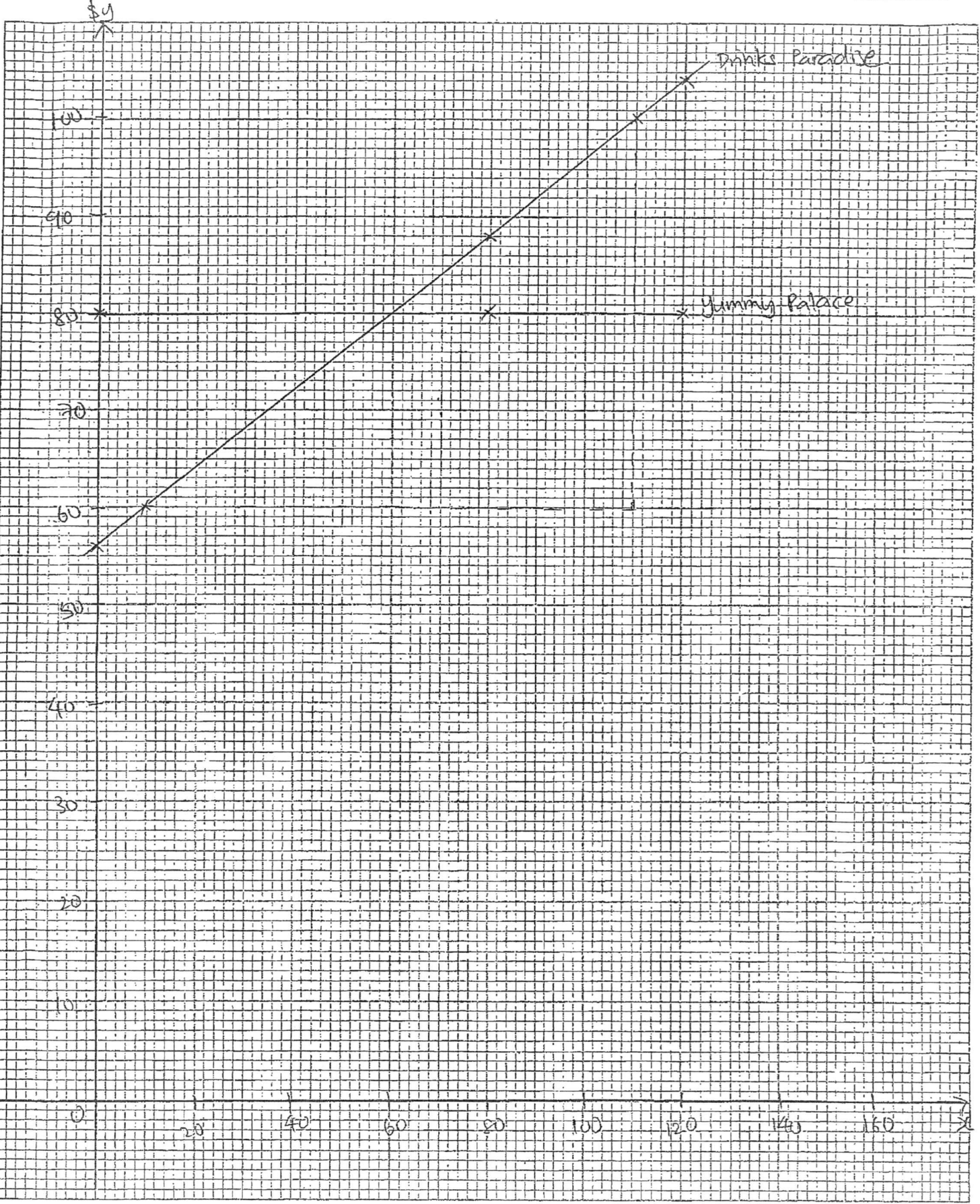

$$(a) \quad p = \$7 \times 8 + \frac{10}{100} \times 80 \times \$4 \quad \left. \vphantom{p} \right\} \text{B1.}$$
$$= 88. \quad (\text{shown}).$$

$$(c) \quad y = 80 \quad \text{--- B1}$$

$$(d) \quad (i) \quad \text{gradient} = \frac{40}{100}$$
$$= 0.4 \quad \text{or} \quad \frac{2}{5}. \quad \text{--- A1}$$

$$(ii) \quad y\text{-intercept} = 56. \quad \text{--- B1}$$

$$(e) \quad 60 \text{ bottles.} \quad \text{--- B1}$$

Note: Students can achieve answer by using graph or by using values in table to calculate. Award marks for either cases.