

Visit

FREETESTPAPER.com

for more papers



Website: [freetestpaper.com](http://www.freetestpaper.com)



[Facebook.com/freetestpaper](https://www.facebook.com/freetestpaper)



[Twitter.com/freetestpaper](https://www.twitter.com/freetestpaper)

Class	Index Number	Name
-------	--------------	------

BUKIT MERAH SECONDARY SCHOOL



END OF YEAR EXAMINATION 2017 SECONDARY 1 EXPRESS

MATHEMATICS

Paper 1

4048/01

5 October 2017

1 hour 15 minutes

Candidates answer on the Question Paper.
No additional material is required.

READ THESE INSTRUCTIONS FIRST

Write your name, class and index number on all the work you hand in.

Write in dark blue or black pen on both sides of the paper.

You may use a pencil for any diagram or graphs.

Do not use staples, paper clips, highlighters, glue or correction fluid.

Answer **all** questions.

If working is needed for any question it must be shown with the answer.

Omission of essential working will result in loss of marks.

Calculators should be used where appropriate.

If the degree of accuracy is not specified in the question, and if the answer is not exact, give the answer to three significant figures. Give the answers in degrees to one decimal place.

For π , use either your calculator value or 3.142, unless the question requires the answer in terms of π .

At the end of the examination, fasten all your work securely together.

The number of marks is given in brackets [] at the end of each question or part question.

The total number of marks for this paper is 50.

Calculator Model:

For Examiner's Use	
Part A (Algebra Component)	
Part B	
Total	

This document consists of **12** printed pages, including this cover page.
Setter: Yvonne Lee

[Turn over

Part A – Answer all questions**1 Simplify**

(a) $(a) \times (3b) - a,$

(b) $x - 2(y - 2x),$

(c) $\frac{4z}{3} - \frac{3(2 - 5z)}{4}.$

Answer (a) [1]

(b) [2]

(c) [2]

2 Factorise

(a) $3p^2q - 12pq + 6pq^2$,

(b) $(v+w) - v(w+v)$.

Answer (a) [1]

(b) [1]

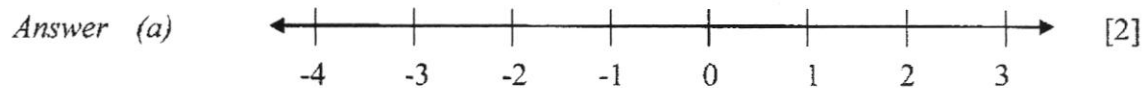
3 (a) Solve the inequality $-4x > 8$ and illustrate your solution on the number line below.(b) Hence, write down the largest integer value of x which satisfies $-4x > 8$.Answer (b) $x =$ [1]

4 Solve

(a) $2(3c-1)-3(2+c)=0$

(b) $\frac{f+2}{5}+1=\frac{f+1}{2}$

Answer (a) $c = \dots\dots\dots$ [2]

(b) $f = \dots\dots\dots$ [3]

 Part B – Answer **all** questions

- 5 (a) Express 0.28 as a fraction in its simplest form.

Answer (a) [1]

- (b) Evaluate $\sqrt{\frac{13.6 - 1.48^2}{\pi}}$, correct your answer to

(i) 2 significant figures,

(ii) 3 decimal places.

Answer (b) (i) [1]

(ii) [1]

-
- 6 Without using a calculator, evaluate $\left(1\frac{1}{2}\right)^2 \div \frac{3}{7} + \left(-\frac{2}{3}\right)$. Show your workings clearly.

Answer [3]

7 When written as a product of their prime factors,

$$p = 2^3 \times 3^9,$$

$$q = 2 \times 3^2 \times 5,$$

$$r = 2^2 \times 3 \times 7.$$

Find

- (a) the value of the cube root of p ,
- (b) the LCM of p , q and r , giving your answer as the product of its prime factors,
- (c) the greatest number that will divide p , q and r exactly.

Answer (a) [1]

(b) LCM = [1]

(c) [1]

8 (a) Apple juice, peach juice and lemonade were used to make a fruit punch in the ratio 5:3:7 respectively. Ali used 2.8 litres of lemonade.

(i) How much apple juice did he use?

Answer (a) (i) l [1]

(ii) How much fruit punch did he make altogether?

Answer (a) (ii) l [1]

(b) Baba makes a fruit punch using mango juice, orange juice and lemonade.

The ratio of mango juice : orange juice is 2:3.

The ratio of orange juice : lemonade is 4:3.

Find the ratio of mango juice : orange juice : lemonade.

Answer (b) : : [1]

- 9 (a) Express 3 centimetres as a percentage of 6 metres.

Answer (a) % [1]

- (b) Express 24 m/s into km/h.

Answer (b) km/h [1]

- 10 In the diagram, $ABCD$ is a trapezium in which $AD = 13$ cm, $AB = 10$ cm, $BC = 20$ cm and $\angle DAB = 90^\circ$. E and F are points on AD and AB respectively such that $AE = 6$ cm and $AF = 8$ cm. Find the area of the shaded region $EFBC$.

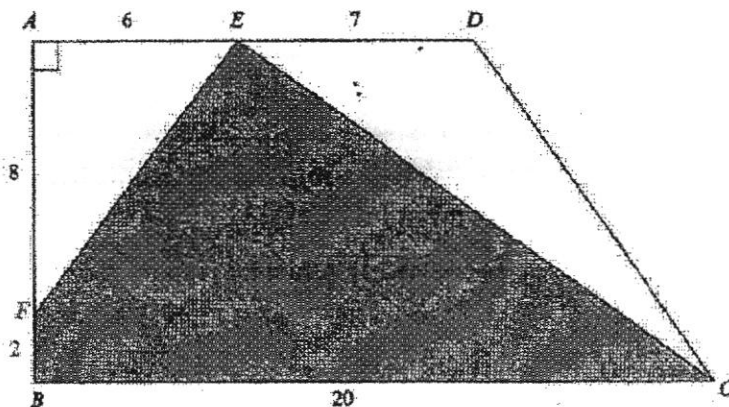

Answer cm^2 [3]

11 Mrs Lee bought 2 books during a sale.

BOOK SALE!



BUY ONE AND GET THE NEXT ONE AT A DISCOUNT OF 30%

\$18 each (inclusive of 7% GST)

Calculate

- (a) the total amount she paid for both books,
- (b) the total amount of GST.

Answer (a) \$ [2]
(b) \$ [2]

12 Given the following sequence,

$$\frac{1}{6} + \frac{1}{3} = \frac{1}{2}$$

$$\frac{1}{12} + \frac{1}{4} = \frac{1}{3}$$

$$\frac{1}{20} + \frac{1}{5} = \frac{1}{4}$$

$$\frac{1}{30} + \frac{1}{6} = \frac{1}{5}$$

⋮

$$\frac{1}{p} + \frac{1}{12} = \frac{1}{11}$$

find

- (a) the 5th line of sequence,
 (b) the value of p ,
 (c) the value of $\frac{1}{98} - \frac{1}{99}$, showing your workings clearly.

Answer (a) [1]

(b) $p =$ [1]

(c) [2]

- 13 In the diagram, UTR is a straight line and TQR is an isosceles triangle such that $QT = QR$. Given that $PQ \parallel RS$, $\angle UTQ = 155^\circ$ and $\angle PQT = 90^\circ$, find

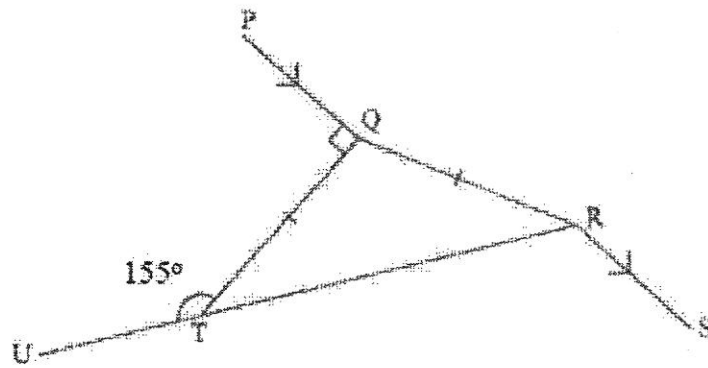

- (a) $\angle TQR$,
 (b) $\angle TRS$.

Answer (a) $\angle TQR = \dots\dots\dots^\circ$ [2]

(b) $\angle TRS = \dots\dots\dots^\circ$ [2]

- 14 (a) Complete the following table for the equation $y = 4 - \frac{1}{2}x$.

x	0	4	8
y			

[2]

- (b) Draw the graph of $y = 4 - \frac{1}{2}x$ for $0 \leq x \leq 8$ on the grid provided below.

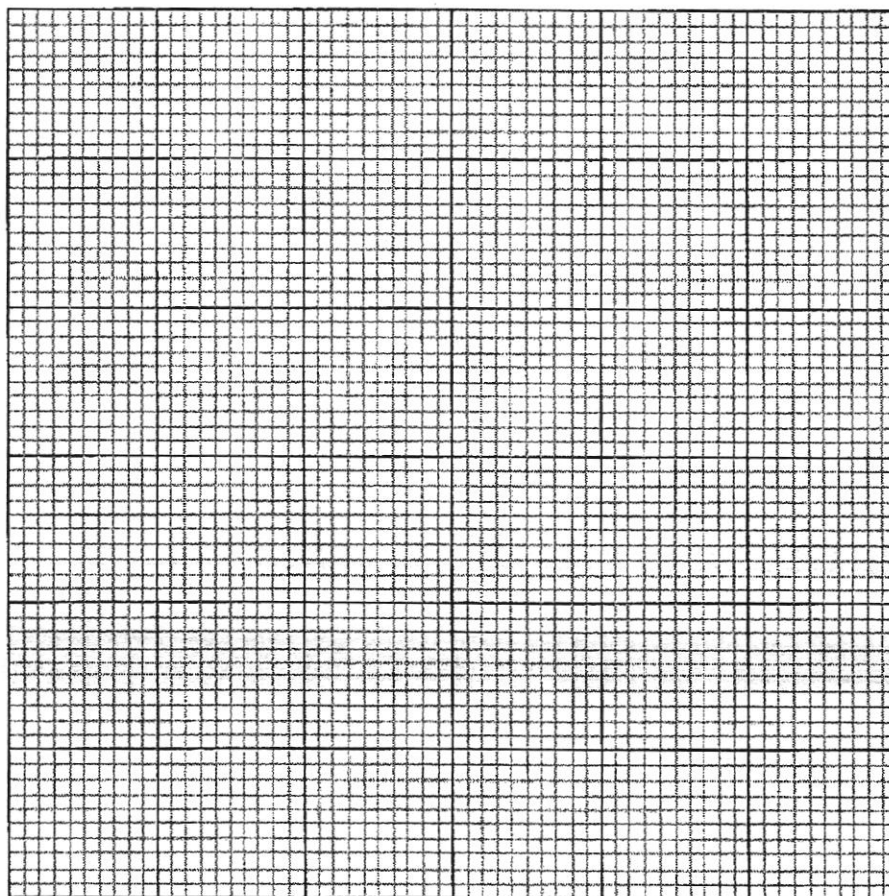

[2]

- (c) Draw a straight line $y = 3$ on the same grid. [1]
- (d) Write down the coordinates of the point of intersection of the two lines.

Answer (d) (..... ,) [1]

End of paper

Class	Index Number	Name
-------	--------------	------

BUKIT MERAH SECONDARY SCHOOL



END OF YEAR EXAMINATION 2017 SECONDARY 1 EXPRESS

MATHEMATICS

Paper 2

4048/02

10 October 2017

1 hour 30 minutes

Additional Materials: Writing paper (5 sheets)
Cover Page (1 sheet)

READ THESE INSTRUCTIONS FIRST

Write your name, class and index number on all the work you hand in.

Write in dark blue or black pen on both sides of the paper.

You may use a pencil for any diagram or graphs.

Do not use staples, paper clips, highlighters, glue or correction fluid.

Answer **all** questions.

If working is needed for any question it must be shown with the answer.

Omission of essential working will result in loss of marks.

Calculators should be used where appropriate.

If the degree of accuracy is not specified in the question, and if the answer is not exact, give the answer to three significant figures. Give the answers in degrees to one decimal place.

For π , use either your calculator value or 3.142, unless the question requires the answer in terms of π .

At the end of the examination, fasten all your work securely together.

The number of marks is given in brackets [] at the end of each question or part question.

The total number of marks for this paper is 60.

For Examiner's Use	
Part A (Algebra Component)	
Part B	
Total	

Calculator Model:

This document consists of **7** printed pages, including this cover page.

Setter: Yvonne Lee

[Turn over

Part A – Answer all questions

1 (a) Solve $\frac{x+3}{4} - \frac{2x-4}{5} = 1$. [3]

(b) If $a=3$, $b=-2$ and $c=5$, evaluate

(i) $a-4(b-2c)$, [1]

(ii) $ac^2 - b^3$. [1]

(c) Soil costs x cents per kilogram.

Peter paid y dollars for some soil.

Find an expression, in terms of x and y , for the number of kilograms of soil that Peter bought.

[2]

2 (a) Find the interior angle of a regular 15-sided polygon. [2]

(b) An n -sided polygon has 2 interior angles measuring 100° each and the remaining interior angles are q° each.

Find an expression for q in terms of n .

[2]

- 3 In a sewing kit, there are blue, green and red buttons. $\frac{1}{5}$ of the buttons are blue and $\frac{4}{7}$ of the remainder are green. The rest are red buttons.

Find

- (a) the fraction of red buttons in the sewing kit, [2]
(b) the ratio of blue buttons to green buttons to red buttons, [1]
(c) the total number of buttons if there are 80 green buttons in the sewing kit. [2]
- 4 (a) The cash price of a new car is \$90 500.

David buys the car under the hire purchase scheme as shown below.

Hire Purchase Scheme

- a deposit of 20% of cash price
- simple interest of 2% per year over 3 years
- repayment to be made monthly

Calculate

- (i) the total amount of interest payable, [3]
(ii) the monthly instalment paid by David. [2]
- (b) A bag costs 1 850 000 Korean Won (KRW). The conversion rate between Singapore dollars and Korean Won is $\text{SGD1} = \text{KRW}815.79$.

Calculate the price of the bag in Singapore dollars. [2]

5 A cylindrical block of metal has radius 10 cm and height 30 cm.

- (a) Calculate its volume, leaving your answer in terms of π . [1]

The block of metal is then melted and recast into 6 similar rods of height 15 cm.

- (b) Show that the radius of the base area of one such rod is 5.77 cm, correct to 3 significant figures. [2]

The diagram shows the cross-sectional view of a box holding the 6 rods. The box is in the shape of a cuboid and the rods just fit into the box.

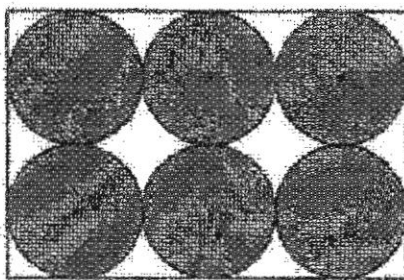

- (c) Calculate the volume of empty space in the box. [3]

6 (a)

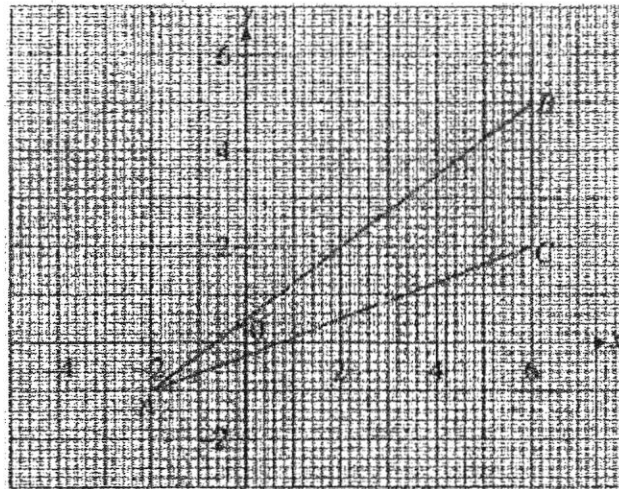

- (i) Calculate the gradient of AB . [1]
- (ii) Write down the equation of BC . [1]
- (iii) Find the area of $\triangle ABC$. [2]

(b) The equation of a function is $y = -\frac{1}{3}x + 2$. Find

- (i) the value of y when $x = \frac{3}{4}$, [1]
- (ii) the value of x when $y = -1$. [2]
- Hence, explain why $(7, -1)$ does not lie on the line. [2]

7 (a) Calculate the total surface area of the prism below. [3]

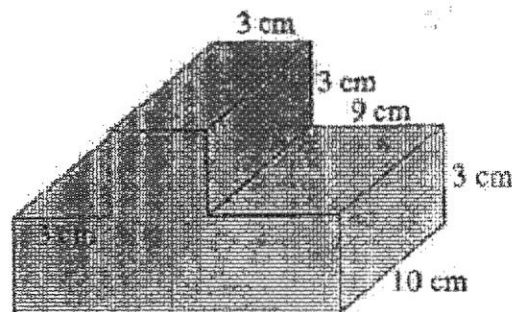

- (b) Mr Lee took 30 mins to drive from Jurong to Changi at an average speed of 72 km/h. He took the same route (but in the opposite direction) at an average speed of 5 km/h faster for his return trip. Find his average speed for the round trip correct to the nearest km/h. [4]

- 8 The pie chart shows how a box of sweets was shared among Alex, Bryan and Clement.

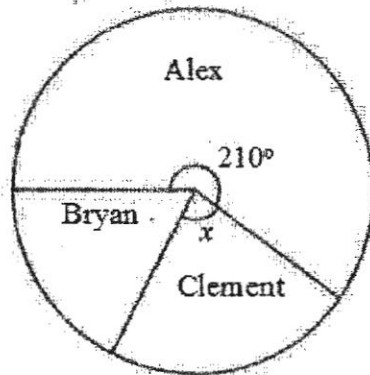

- (a) Find the fraction of the sweets that Alex received. [1]
 (b) If Clement received 22.5% of the sweets, find x . [1]
 (c) If Bryan received 345 sweets, how many sweets were there in the box? [2]
- 9 In the diagram, the shape is made up of trapezium $ABFG$, rectangle $BCEF$ and semicircle CDE .

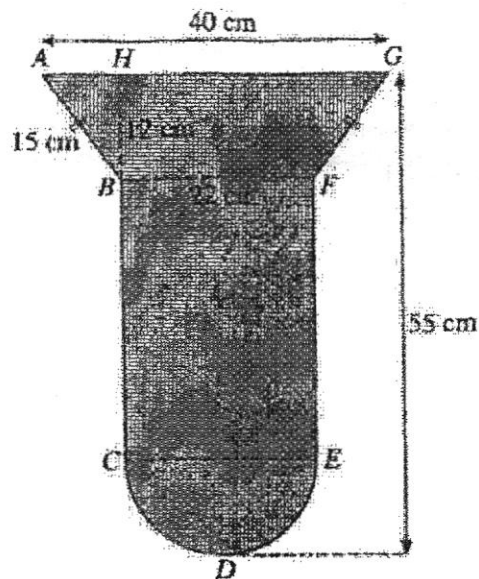

Find

- (a) its perimeter, [3]
 (b) its area. [4]

- 10 Mrs Lee would like to dine at the Big Signboard Thai Restaurant. Below shows the pricing of the food items she would like to order. There is a service charge of 10% and GST of 7% but no service charge is imposed for takeout.

Big Signboard Thai Restaurant	
Pineapple rice	\$13.50
Green papaya salad	\$7.90
Green curry	\$10.90
Thai fish cake	\$6.70
Chendol	\$4.30

- (a) How much more must Mrs Lee pay if she were to dine in instead of takeout? [4]
- (b) If Mrs Lee has only \$50, suggest on which is a better option for her. Support your answer with relevant workings. [2]

End of paper

BMSS 1Exp End-Of-Year Examination 2017
(Mathematics P1) – Marking Scheme

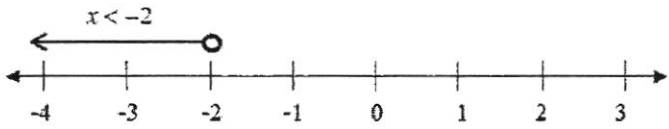
Qn	Solution	Marks	Remarks	
1	a	$3ab - a$	B1	
	b	$x - 2y + 4x$ $= 5x - 2y$	M1 A1	
	c	$\frac{4z}{3} - \frac{3(2-5z)}{4}$ $= \frac{16z - 9(2-5z)}{12}$ $= \frac{16z - 18 + 45z}{12}$ $= \frac{61z - 18}{12}$	M1 A1	common denominator
2	a	$3pq(p - 4 + 2q)$	B1	
	b	$(v+w)(1-v)$	B1	
3	a	 A number line from -4 to 3 with tick marks at every integer. An open circle is drawn at -2, and an arrow points to the left from this circle, labeled 'x < -2'.	B1, B1	B1 for correct inequality B1 for correct illustration on number line
	b	$x = -3$	B1	
4	a	$2(3c-1) - 3(2+c) = 0$ $6c - 2 - 6 - 3c = 0$ $c = 2\frac{2}{3}$ or $\frac{8}{3}$	M1 A1	correct expansion
	b	$\frac{f+2}{5} + 1 = \frac{f+1}{2}$ $\frac{f+7}{5} = \frac{f+1}{2}$ $2(f+7) = 5(f+1)$ $2f+14 = 5f+5$ $f = 3$	M1 M1 A1	fraction=fraction cross-multiply
5	a	$\frac{7}{25}$	B1	
	bi	1.9 (2 s.f.)	B1	
	bii	1.906 (3 decimal places)	B1	

6	$\left(1\frac{1}{2}\right)^2 \div \frac{3}{7} + \left(-\frac{2}{3}\right)$ $= \frac{9}{4} \div \frac{3}{7} - \frac{2}{3}$ $= \frac{9}{4} \times \frac{7}{3} - \frac{2}{3}$ $= \frac{21}{4} - \frac{2}{3}$ $= \frac{63-8}{12}$ $= 4\frac{7}{12} \text{ or } \frac{55}{12}$	M1 M1 A1	removing the brackets \div to \times
7	<p>a $\sqrt[3]{p} = 2 \times 3^3$ $= 54$</p> <p>b $\text{LCM} = 2^3 \times 3^9 \times 5 \times 7$</p> <p>c $\text{HCF} = 2 \times 3$ $= 6$</p>	B1 B1 B1	
8	<p>ai 7 parts \rightarrow 2.8l 1 part \rightarrow 0.4l 5 parts \rightarrow 2l</p> <p>aii 15 parts \rightarrow 6l</p> <p>b mango : orange 2 : 3 8 : 12 orange : lemonade 4 : 3 12 : 9 \therefore mango : orange : lemonade = 8 : 12 : 9</p>	B1 B1 B1	
9	<p>a $\frac{3}{600} \times 100\% = 0.5\%$</p> <p>b 24 m \rightarrow 1 s 1440 m \rightarrow 60 s 86400 m \rightarrow 1 h 86.4 km \rightarrow 1 h \therefore 86.4 km/h or $86\frac{2}{5}$ km/h</p>	B1 B1	

10		<p>Divide shaded diagram into 2 parts by drawing a line perpendicular to BC through E.</p> <p>area of shaded trapezium $= \frac{1}{2}(2+10)6 = 36 \text{ cm}^2$</p> <p>area of shaded triangle $= \frac{1}{2} \times 14 \times 10 = 70 \text{ cm}^2$</p> <p>area of shaded region $EFBC = 36 + 70$ $= 106 \text{ cm}^2$</p>	<p>M1</p> <p>M1</p> <p>A1</p>	<p>accept alternative method:</p> <p>area of trapezium $ABCD = 165 \text{ cm}^2$ [M1]</p> <p>area of $\triangle AEF = 24 \text{ cm}^2$</p> <p>area of $\triangle EDC = 35 \text{ cm}^2$ [M1]</p> <p>area of shaded region $EFBC = 165 - 24 - 35 = 106 \text{ cm}^2$ [A1]</p>
11	a	<p>total amount paid $= \frac{70}{100} \times 18 + 18$ $= \\$30.60$</p>	<p>M1</p> <p>A1</p>	
	b	<p>$\text{GST} = \frac{7}{107} \times 30.60$ $= \\$2$</p>	<p>M1</p> <p>A1</p>	
12	a	<p>$\frac{1}{42} + \frac{1}{7} = \frac{1}{6}$</p>	<p>A1</p>	
	b	<p>$p = 132$</p>	<p>A1</p>	
	c	<p>$\frac{1}{99 \times 98} + \frac{1}{99} = \frac{1}{98}$</p> <p>$\frac{1}{98} - \frac{1}{99} = \frac{1}{99 \times 98}$</p> <p>$= \frac{1}{9702}$</p>	<p>M1</p> <p>A1</p>	
13	a	<p>$\angle QTR = 180^\circ - 155^\circ$ (adj \angles on a str. line) $= 25^\circ$</p> <p>$\angle QRT = \angle QTR = 25^\circ$ (base \angles of isos. tri)</p> <p>$\angle TQR + 25^\circ + 25^\circ = 180^\circ$ (\angle sum of tri) $\angle TQR = 130^\circ$</p>	<p>M1</p> <p>A1</p>	
	b	<p>$\angle PQR + 90^\circ + 130^\circ = 360^\circ$ (\angles at a pt) $\angle PQR = 140^\circ$</p> <p>$\angle QRS = \angle PQR = 140^\circ$ (alt \angles, $PQ \parallel RS$)</p> <p>$\angle TRS = 140^\circ - 25^\circ$ $= 115^\circ$</p>	<p>M1</p> <p>A1</p>	

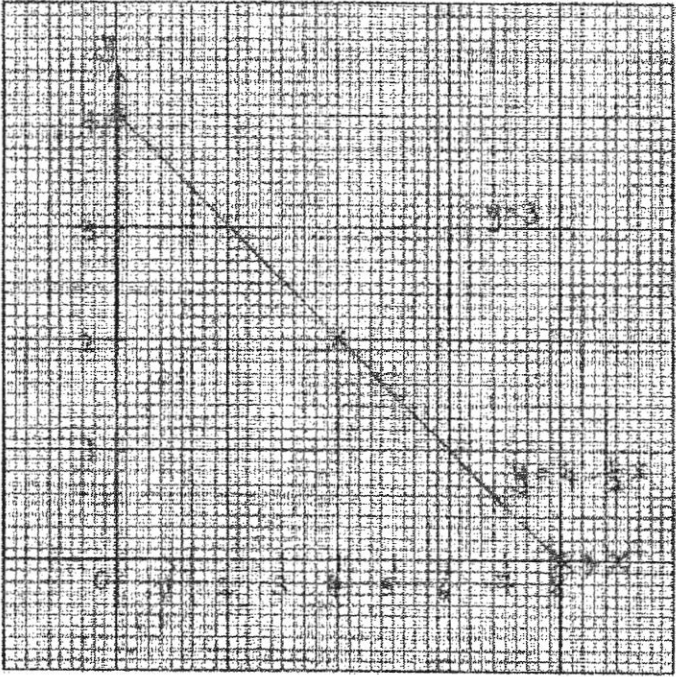
14	a	<table border="1" style="margin-left: auto; margin-right: auto;"> <tr> <td style="text-align: center;">x</td> <td style="text-align: center;">0</td> <td style="text-align: center;">4</td> <td style="text-align: center;">8</td> </tr> <tr> <td style="text-align: center;">y</td> <td style="text-align: center;">4</td> <td style="text-align: center;">2</td> <td style="text-align: center;">0</td> </tr> </table>	x	0	4	8	y	4	2	0	B2	minus 1m for every wrong / missing answer
	x	0	4	8								
	y	4	2	0								
	b		B2	minus 1m for each error type - incorrect range of x , plotting error, inappropriate scale, missing axes and missing eqn of line								
c	Refer to b	B1										
d	(2, 3)	B1										

BMSS 1Exp End-Of-Year Examination 2017
(Mathematics P2) – Marking Scheme

Qn	Solution	Marks	Remarks	
1	a	$\frac{x+3}{4} - \frac{2x-4}{5} = 1$ $\frac{5(x+3) - 4(2x-4)}{20} = 1$ $\frac{-3x+31}{20} = 1$ $-3x+31 = 20$ $x = 3\frac{2}{3} \text{ or } \frac{11}{3}$	M1 M1 A1	LHS into a single fraction cross-multiply
	bi	$3 - 4[-2 - 2(5)] = 51$	A1	
	bii	$3(5)^2 - (-2)^3 = 83$	A1	
	c	$\$y = 100y \text{ cents}$ $x \text{ cents} \rightarrow 1 \text{ kg}$ $1 \text{ cent} \rightarrow \left(\frac{1}{x}\right) \text{ kg}$ $100y \text{ cents} \rightarrow \left(\frac{100y}{x}\right) \text{ kg}$	M1 A1	
2	a	$\text{interior angle} = \frac{(15-2) \times 180^\circ}{15}$ $= 156^\circ$	M1 A1	
	b	$(n-2) \times q + 100 + 100 = (n-2) \times 180$ $(n-2)q + 200 = 180n - 360$ $q = \frac{180n - 560}{n-2}$	M1 A1	
3	a	$\text{fraction of green buttons} = \frac{4}{7} \times \frac{4}{5}$ $= \frac{16}{35}$ $\text{fraction of red buttons} = 1 - \frac{1}{5} - \frac{16}{35}$ $= \frac{12}{35}$	M1 A1	
	b	$\frac{1}{5} : \frac{16}{35} : \frac{12}{35} = 7 : 16 : 12$	A1	
	c	$16 \text{ parts} \rightarrow 80$ $1 \text{ part} \rightarrow 5$ $35 \text{ parts} \rightarrow 175$	M1 A1	
4	ai	amount borrowed = $\frac{80}{100} \times 90500$		

		$= \$72400$	M1	
		total interest = $72400 \times \frac{2}{100} \times 3$ $= \$4344$	M1 A1	
	aii	total amount payable = $72400 + 4344$ $= \$76744$ monthly instalment = $\frac{76744}{36}$ $= \$2131.78$	M1 A1	
	b	price in SGD = $\frac{1850000}{815.79}$ $= \$2267.74$	M1 A1	
5	a	volume = $\pi(10^2)(30)$ $= 3000\pi \text{ cm}^3$	B1	
	b	$6 \times \pi r^2(15) = 3000\pi$ $r = 5.7735 \text{ cm}$ rej. -5.7735 $= 5.77$ (shown)	M1 A1	
	c	length = $5.7735 \times 6 = 34.641 \text{ cm}$ breadth = $5.7735 \times 4 = 23.094 \text{ cm}$ empty space (cross sectional) $= (34.641)(23.094) - 6[\pi(5.7735)^2]$ $= 171.681 \text{ cm}^2$ empty space in box = 171.681×15 $= 2575.220$ $= 2580 \text{ cm}^3$ (3 s.f.)	M1 M1 A1	correct dimension of box accept alternative method: vol. of box $= 34.641 \times 23.094$ $\times 15$ $= 11999.99 \text{ cm}^3$ [M1] empty space $= 11999.99$ $- 3000\pi$ $= 2580 \text{ cm}^3$ [A1]
6	ai	gradient = $\frac{3}{4}$	B1	
	aii	$x = 6$	B1	
	a iii	area = $\frac{1}{2} \times 3 \times 8$ $= 12 \text{ units}^2$	M1 A1	
	bi	$y = -\frac{1}{3}\left(\frac{3}{4}\right) + 2 = 1\frac{3}{4}$	B1	

	bii	$-1 = -\frac{1}{3}x + 2$ $x = 9$ <p>when $y = -1$, $x = 9$ and not 7.</p>	B1 B1	
7	a	<p>base area = $15 \times 3 + 3 \times 3$ = 54 cm^2</p> <p>perimeter of base = $3 + 3 + 3 + 3 + 9 + 3 + 15 + 3$ = 42 cm</p> <p>area of lateral faces = 42×10 = 420 cm^2</p> <p>S.A. = $420 + 2 \times 54$ = 528 cm^2</p>	M1 M1 A1	
	b	<p>distance from Jurong to Changi = $72 \times \frac{1}{2}$ = 36 km</p> <p>time taken for return trip = $\frac{36}{77}$</p> <p>average speed for the round trip = $\frac{36 + 36}{\frac{1}{2} + \frac{36}{77}}$ = 74.416 km/h = 74 km/h (nearest km/h)</p>	M1 M1 M1 A1	
8	a	$\frac{210}{360} = \frac{7}{12}$	B1	
	b	$x = \frac{22.5}{100} \times 360$ = 81°	B1	
	c	<p>fraction of sweets Bryan received = $\frac{360 - 210 - 81}{360}$ = $\frac{23}{120}$</p> <p>no. of sweets in a box = $\frac{120}{23} \times 345$ = 1800</p>	M1 A1	
9	a	$BC = FE = 55 - 12 - 11$ = 32 cm	M1	

		$\text{length of arc CE} = \frac{1}{2} \times 2\pi(11)$ $= 34.558 \text{ cm}$	M1	
		$\text{perimeter} = 40 + 15 + 32 + 34.558 + 32 + 15$ $= 169 \text{ cm (3 s.f.)}$	A1	
	b	$\text{area of trapezium} = \frac{1}{2}(40 + 22)(12) = 372 \text{ cm}^2$	M1	
		$\text{area of rectangle} = 22 \times 32 = 704 \text{ cm}^2$	M1	
		$\text{area of semicircle} = \frac{1}{2} \times \pi(11)^2 = 190.07 \text{ cm}^2$	M1	
		$\text{area} = 372 + 704 + 190.07 = 1270 \text{ cm}^2 \text{ (3 s.f.)}$	A1	
10	a	<u>Dine in</u> $\text{cost of food} = 13.50 + 7.90 + 10.90 + 6.70 + 4.30$ $= \$43.30$	M1	
		$\text{cost of food including service charge} = 1.1 \times 43.30$ $= \$47.63$		
		$\text{cost of food including service charge and GST}$ $= 1.07 \times 47.63$ $= \$50.96$	M1	
		<u>Takeout</u> $\text{cost of food including GST} = 1.07 \times 43.30$ $= \$46.33$	M1	
		$\text{amount} = 50.96 - 46.33$ $= \$4.63$	A1	
	b	<p>Since $\\$50 - \\$50.96 = -\\$0.96$, Mrs Lee does not have enough money to dine in with the purchase of the food items. I would suggest that she takeout her purchase.</p>	M1	
			A1	