

*Visit*

**FREETESTPAPER.com**

*for more papers*



Website: [freetestpaper.com](http://www.freetestpaper.com)



[Facebook.com/freetestpaper](https://www.facebook.com/freetestpaper)



[Twitter.com/freetestpaper](https://www.twitter.com/freetestpaper)

CANDIDATE NAME	( )	CLASS	
-------------------	-----	-------	--



**Anglo-Chinese School  
(Barker Road)**

**END-OF-YEAR EXAMINATION 2021**

**SECONDARY ONE  
EXPRESS**

**MATHEMATICS  
PAPER 1**

**1 HOUR 15 MINUTES**

Candidates answer on the Question Paper.

**READ THESE INSTRUCTIONS FIRST**

Write your index number and name on all the work you hand in.  
Write in dark blue or black pen.  
You may use an HB pencil for any diagrams or graphs.  
Do not use staples, paper clips, glue or correction fluid.

Answer **all** questions.

If working is needed for any question it must be shown with the answer.

Omission of essential working will result in loss of marks.

The use of an approved scientific calculator is expected, where appropriate.

If the degree of accuracy is not specified in the question, and if the answer is not exact, give your answer to three significant figures. Give answers in degrees to one decimal place.

For  $\pi$ , use either your calculator value or 3.142, unless the question requires the answer in terms of  $\pi$ .

At the end of the examinations, fasten your work securely together.  
The number of marks is given in brackets [ ] at the end of each question or part question.  
The total of the marks for this paper is 50.

For Examiner's Use

Answer **all** the questions.

1 (a) Calculate  $\frac{\sqrt[3]{3.41}}{18.5 - 2.81^2}$ .

Write down the first 5 digits on your calculator display.

Answer \_\_\_\_\_ [1]

(b) Write your answer to part (a) correct to 3 decimal places.

Answer \_\_\_\_\_ [1]

2 By rounding each number to 1 significant figure, estimate the value of

$$\frac{62.89 \times 8.93}{3.12}$$

You must show your working.

Answer \_\_\_\_\_ [2]

3 Simplify  $4y - (13y - 5x)$ .

Answer \_\_\_\_\_ [2]

4 Factorise completely  $7a - 21ay$ .

Answer \_\_\_\_\_ [2]

5 Write these numbers in order of size, starting with the smallest.

$$\frac{3}{5} \quad 0.75\% \quad \frac{\sqrt{3}}{2} \quad \frac{\pi}{4} \quad 0.57$$

Answer \_\_\_\_\_, \_\_\_\_\_, \_\_\_\_\_, \_\_\_\_\_, \_\_\_\_\_ [2]  
 smallest largest

6 1 5  $\pi$   $\frac{22}{7}$  2

List down

(a) all the prime numbers,

Answer \_\_\_\_\_ [1]

(b) all the rational numbers.

Answer \_\_\_\_\_ [1]

7 In the diagram,  $AB = 5$  cm,  $BC = 7$  cm,  $BE = 4$  cm.

$BE$  is perpendicular to  $AD$  and  $BF$  is perpendicular to  $DC$ .

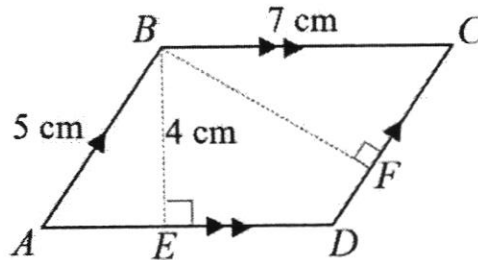

Find  $BF$ .

Answer \_\_\_\_\_ cm [2]

- 8 Express  $\frac{5x}{3} - \frac{2x+y}{4}$  as a single fraction in its simplest form.

*Answer* \_\_\_\_\_ [3]

---

- 9 The price of a house at the end of 2019 was 9% **higher** than at the end of 2018.  
The price of the house at the end of 2020 was 9% **lower** than at the end of 2019.

Jim says that the price of the house at the end of 2020 will be the same as that in 2018.  
Is he correct? Show your working to support your answer

*Answer*

[3]

- 10 (a) Convert 72 km/h to m/s.

Answer \_\_\_\_\_ m/s [2]

- (b) 50 g of meat costs  $x$  dollars.  
Find an expression, in dollars, for the cost of  $y$  kg of meat.

Answer \$ \_\_\_\_\_ [2]

- 11 Amy and Ben each have a savings account.  
The ratio of Amy's savings : Ben's savings = 7 : 9

They each spend \$50 from their savings.

The new ratio of Amy's savings : Ben's savings = 3 : 4

Find how much money they have in total at the beginning.

Answer \$ \_\_\_\_\_ [4]

- 12 The figure below shows a large square  $ABCD$  and a small square in the centre. There are 4 semi-circles and 4 quadrants each with a radius of 7 cm.

Find the area of the shaded part as a percentage of the unshaded part.

(Use  $\pi = \frac{22}{7}$ )

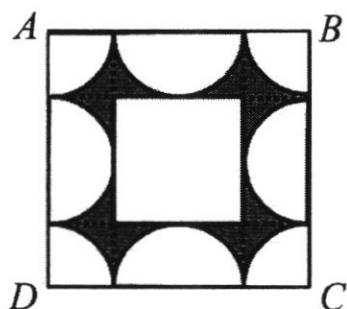

Answer \_\_\_\_\_ % [4]

13 (a)  $r = -q^2 \left( \frac{1}{4} - p \right)$ .

Find the value of  $r$  when  $q = -2$  and  $p = 3$ .

Answer \_\_\_\_\_ [1]

- (b) I am thinking of a number  $n$ .  
32 divided by the sum of  $n$  and 3 gives me 8.  
What is the number?

Answer \_\_\_\_\_ [3]

- 14 (a) Construct quadrilateral  $ABCD$  such that  $BC = 7$  cm,  $AD = 6$  cm, angle  $ABC = 80^\circ$  and angle  $BAD = 100^\circ$ .  
 $AB$  has already been drawn below.

*Answer*



[2]

- (b) Measure and write down the length of the diagonal  $BD$ .

*Answer* \_\_\_\_\_ cm [1]

- (c) Measure and write down the size of angle  $ADC$ .

*Answer* \_\_\_\_\_  $^\circ$  [1]

15

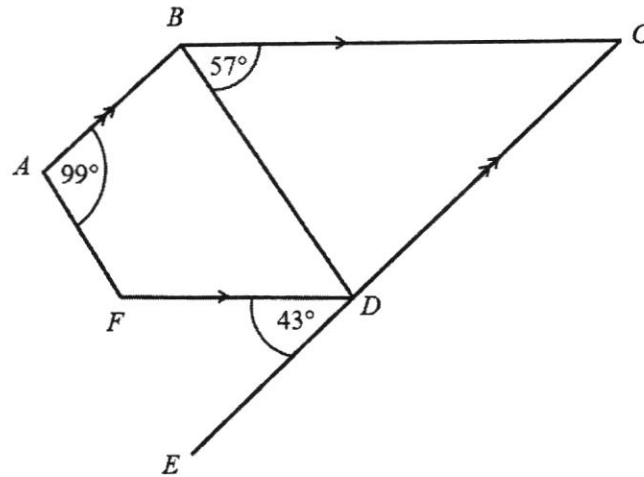

In the diagram,  $AB$  is parallel to  $EDC$  and  $BC$  is parallel to  $FD$ .  
 Angle  $CBD = 57^\circ$ , angle  $EDF = 43^\circ$  and angle  $FAB = 99^\circ$ .

- (a) Complete these statements by calculating the size of each angle.  
 Give a reason for each statement.

Statement	Reason
Angle $BCD =$ _____ $^\circ$	_____ [1]
Angle $BDF =$ _____ $^\circ$	_____ [1]

- (b) Calculate angle  $AFD$ .

Answer \_\_\_\_\_  $^\circ$  [2]

- (c) John says that  $AF$  is parallel to  $BD$ . Do you agree or disagree?  
 You must show your calculations.

Answer

\_\_\_\_\_ because \_\_\_\_\_ [1]  
 \_\_\_\_\_

16

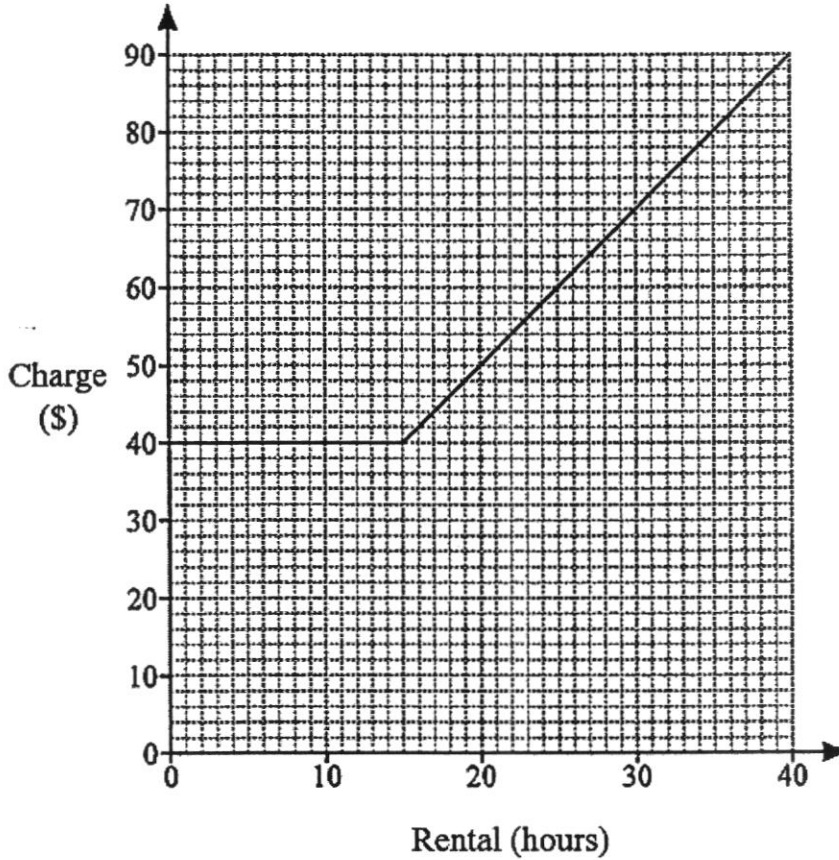

The graph shows the charge imposed by a company for the rental of an electric bike. The charge depends on the number of hours of rental.

- (a) How much does the company charge for rental of an electric bike for 35 hours?

Answer \$ \_\_\_\_\_ [1]

- (b) Complete these sentences.

The company charges a fixed cost of \$ \_\_\_\_\_ for rental of an electric bike up to \_\_\_\_\_ hours.

Each additional hour costs \$ \_\_\_\_\_. [2]

- (c) Another company charges a rate of \$4 per hour, without any fixed cost. Draw on the same grid the graph representing this company's charging model. [1]

- (d) Complete the sentence.

Both companies charge the same amount to rent an electric bike for \_\_\_\_\_ hours. [1]

CANDIDATE NAME	( )	CLASS	
-------------------	-----	-------	--



**Anglo-Chinese School  
(Barker Road)**

**END-OF-YEAR EXAMINATION 2021**

**SECONDARY ONE  
EXPRESS**

**MATHEMATICS  
PAPER 2**

**1 HOUR 15 MINUTES**

Candidates answer on the Question Paper.

**READ THESE INSTRUCTIONS FIRST**

Write your index number and name on all the work you hand in.

Write in dark blue or black pen.

You may use an HB pencil for any diagrams or graphs.

Do not use staples, paper clips, glue or correction fluid.

Answer **all** questions.

If working is needed for any question it must be shown with the answer.

Omission of essential working will result in loss of marks.

The use of an approved scientific calculator is expected, where appropriate.

If the degree of accuracy is not specified in the question, and if the answer is not exact, give your answer to three significant figures. Give answers in degrees to one decimal place.

For  $\pi$ , use either your calculator value or 3.142, unless the question requires the answer in terms of  $\pi$ .

At the end of the examinations, fasten your work securely together.

The number of marks is given in brackets [ ] at the end of each question or part question.

The total of the marks for this paper is 50.

For Examiner's Use

Answer **all** the questions.

1 Expressed as a product of its prime factors,  $156 = 2^2 \times 3 \times 13$ .

(a) Express 90 as a product of its prime factors.

Answer \_\_\_\_\_ [1]

(b) Find the lowest common multiple of 90 and 156.

Answer \_\_\_\_\_ [1]

(c) The number  $\frac{156}{k}$  is a perfect square. Find  $k$ .

Answer  $k =$  \_\_\_\_\_ [1]

(d) The highest common factor of 156 and  $x$  is 26.  
 $x$  is between 100 and 200.  
 Find the smallest possible value of  $x$ .

Answer  $x =$  \_\_\_\_\_ [2]

- 2 The variables  $x$  and  $y$  are connected by the equation  $y + 2x = 4$ .  
The table shows some corresponding values of  $x$  and  $y$ .

$x$	-1	1	3
$y$	6	$p$	-2

- (a) Find the value of  $p$ .

Answer  $p =$  \_\_\_\_\_ [1]

- (b) On the axes below, draw the graph of  $y + 2x = 4$  for values of  $x$  from  $-1$  to  $3$ .

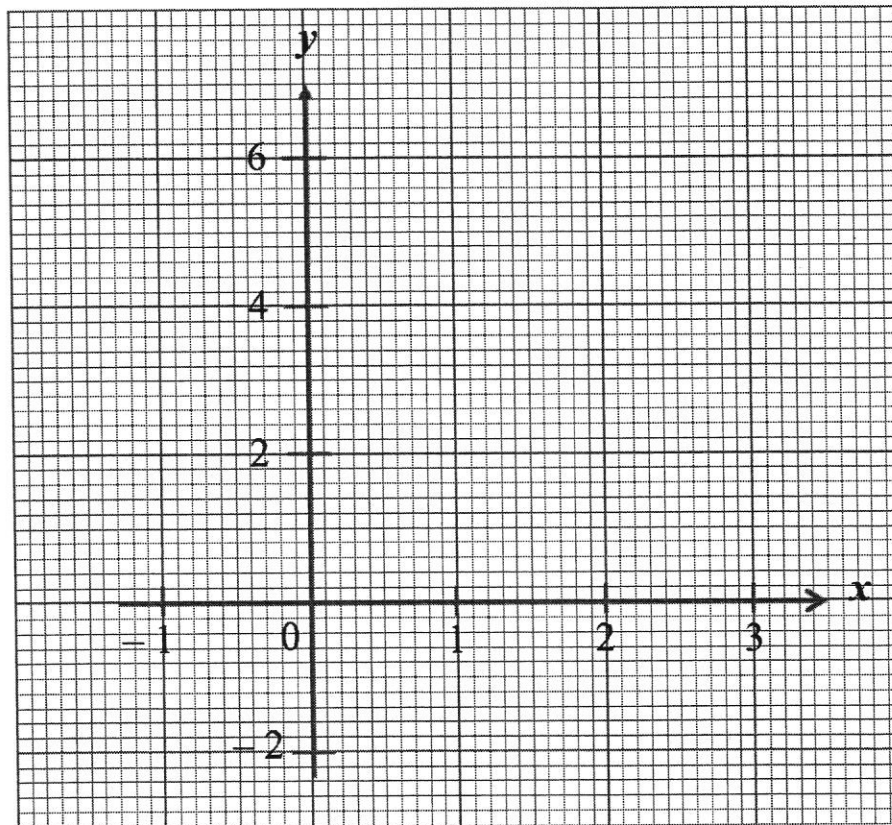

[2]

- (c) From your graph,  
(i) write down the coordinates of the point where the line meets the  $x$ -axis,

Answer ( \_\_\_\_\_ , \_\_\_\_\_ ) [1]

- (ii) find the value of  $x$  when  $y = -1$ .

Answer  $x =$  \_\_\_\_\_ [1]

3 The diagram below shows a series of patterns made using shaded and unshaded circles.

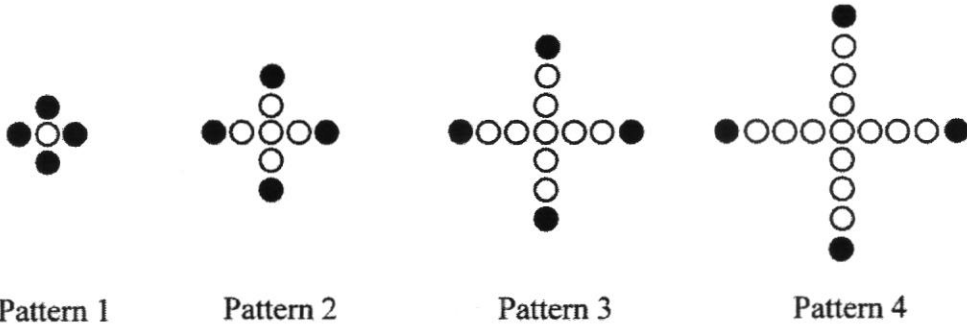

(a) Complete the table.

Pattern	Number of circles	Number of unshaded circles
1	$1 + 4 = 5$	1
2	$1 + 4 + 4 = 9$	5
3	$1 + 4 + 4 + 4 = 13$	9
4	$1 + 4 + 4 + 4 + 4 = 17$	13
5		

[1]

(b) Write down an expression, in terms of  $n$ , for the number of circles in Pattern  $n$ .

Answer \_\_\_\_\_ [1]

(c) Explain why the number of circles in the sequence is always odd.

Answer \_\_\_\_\_  
 \_\_\_\_\_  
 \_\_\_\_\_

[1]

(d) Would there be a pattern where there are 178 unshaded circles?  
 Show your working clearly.

Answer \_\_\_\_\_ [2]

- 4  $JABCD$  shows part of a regular ten-sided polygon.  
 $O$  is the centre of the polygon.

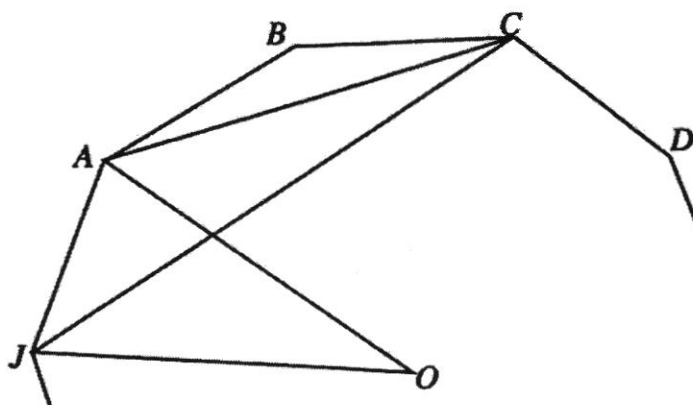

- (a) Find  
 (i) angle  $ABC$ ,

Answer \_\_\_\_\_ ° [2]

- (ii) angle  $AOJ$ ,

Answer \_\_\_\_\_ ° [1]

- (iii) angle  $CAJ$ .

Answer \_\_\_\_\_ ° [2]

- 5 The figure shows a solid prism with a uniform cross-section  $ABCD$  in the shape of a trapezium.

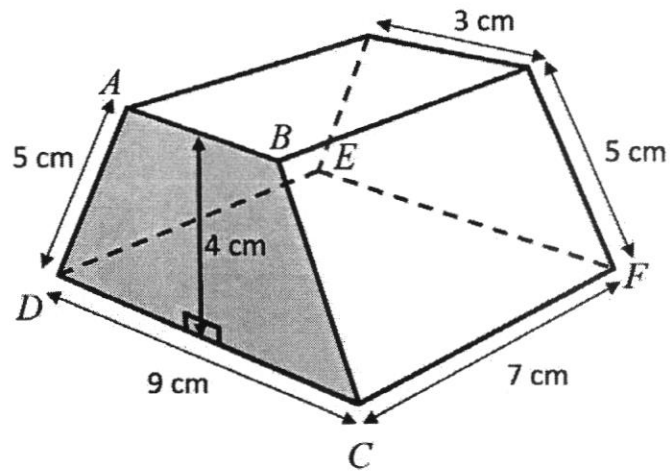

- (a) Show that the area of the cross-section  $ABCD$  is  $24 \text{ cm}^2$ .

*Answer*

[1]

- (b) Calculate the volume of the prism.

*Answer* \_\_\_\_\_  $\text{cm}^3$  [1]

(c) Calculate the total surface area of the prism.

Answer \_\_\_\_\_  $\text{cm}^2$  [3]

- 6 Two trains,  $A$  and  $B$ , left their respective stations and travelled at a constant speed in opposite directions, on parallel tracks.

Train  $A$  travelled at  $70$  km/h while Train  $B$  travelled at  $85$  km/h.

At a certain point in time, both trains pass each other at Junction  $X$ .

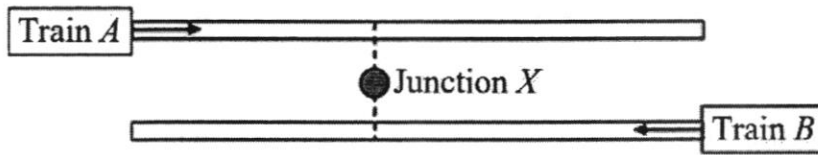

- (a) Train  $A$  had travelled  $x$  km when it reached Junction  $X$ . Write down, in terms of  $x$ , the time taken for Train  $A$  to travel from its station to Junction  $X$ .

Answer \_\_\_\_\_ hours [1]

- (b) Train  $B$  had travelled  $45$  km more than Train  $A$  when it reached Junction  $X$ . Write down, in terms of  $x$ , the time taken for Train  $B$  to travel from its station to Junction  $X$ .

Answer \_\_\_\_\_ hours [1]

- (c) Hence or otherwise, form an equation in  $x$  and solve it.

Answer

[3]

- (d) Find the distance between the two stations.

Answer \_\_\_\_\_ km [1]

- 7 (a) The following table shows various foreign exchange rates, against the Singapore Dollar (SGD).

Code	Currency	Unit	SGD
USD	US Dollar	1	1.3409
AUD	Australian Dollar	1	0.9848
JPY	Japanese Yen	100	1.2175
HKD	Hong Kong Dollar	100	17.1850

For example,

1 US Dollar = 1.3409 Singapore Dollars (SGD) and

100 Japanese Yen = 1.2175 Singapore Dollars.

- (i) Jenny bought a handbag in Hong Kong for HKD 350.  
Calculate the cost in SGD.

Answer SGD \_\_\_\_\_ [2]

- (ii) A tourist from Australia bought a bag for SGD \$294.35.  
The amount paid included a commission of 1.5% because the tourist paid in AUD.

What was the price of the bag in AUD, excluding the commission, correct to the nearest dollar?

Answer AUD \_\_\_\_\_ [2]

- (b) Jim puts a certain amount of money into a savings account paying simple interest of 2% per annum.  
At the end of 2 years, the total amount of money in his account is \$3120.

Find the amount of money that Jim put into the account.

*Answer* \$ \_\_\_\_\_ [2]

8

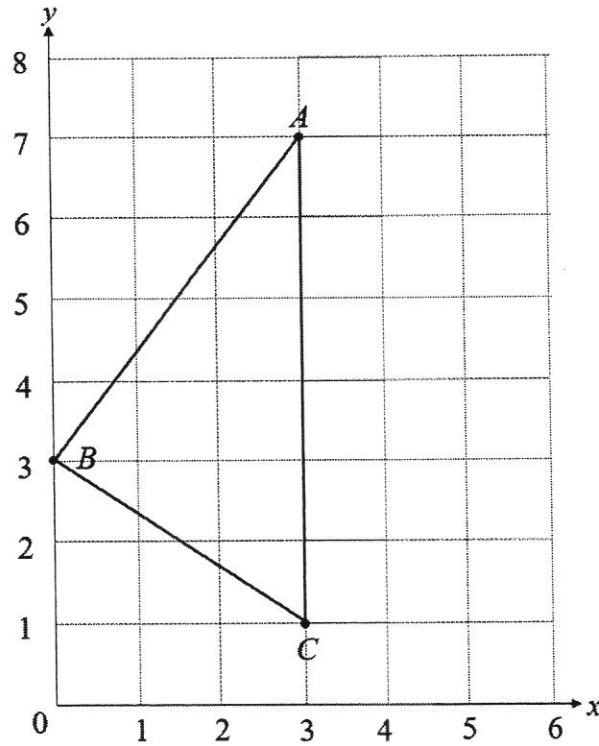

The diagram shows a triangle  $ABC$ .

$A$ ,  $B$  and  $C$  are the points  $(3, 7)$ ,  $(0, 3)$  and  $(3, 1)$  respectively.

- (a) The quadrilateral  $ABCD$  is symmetrical about the line  $AC$ .
- (i) Write down the coordinates of point  $D$ .

Answer ( \_\_\_\_\_ , \_\_\_\_\_ ) [1]

- (ii) Find the area of the quadrilateral  $ABCD$ .

Answer \_\_\_\_\_ unit<sup>2</sup> [2]

(iii) What is the special name given to this quadrilateral?

*Answer* \_\_\_\_\_ [1]

(b) (i) Find the gradient of the line  $AB$ .

*Answer* \_\_\_\_\_ [1]

(ii) Write down the equation of the line  $AB$ .

*Answer* \_\_\_\_\_ [2]

- 9 Jeremy owns a car of engine capacity of 1599 cc.  
He drives on average about 11 000 km per year in his car.  
His car travels 11 km on every litre of petrol.

The cost of petrol can be estimated based on the following:

<u>Engine Capacity (cc)</u>	<u>Cost of petrol per litre</u>
< 1000	\$2.47
$1000 \leq \text{cc} < 1600$	\$2.49
$\geq 1600$	\$2.58

- (a) Calculate the amount that Jeremy pays for petrol in a year.

Answer \$ \_\_\_\_\_ [2]

- (b) In addition to petrol, Jeremy estimates that he will have to pay for the following extra costs **each year**:

• Car Insurance	\$1650 (Before NCD*)
• Electronic Road Pricing (ERP)	\$920
• Servicing and other maintenance + Road Tax	\$2000
• Parking	\$2640

\*NCD: No-claim discount. Jeremy enjoys a 40% discount on car insurance because he has not made any claim.

Jeremy estimates that, if he did not have a car, he would incur **all** of the following **monthly** travel costs from taking public transport.

• MRT	\$50
• Bus	\$55
• Taxis	\$375

Would it be cheaper for Jeremy to use other transport instead of his car?  
Show working to support your answer.

[4]



Anglo-Chinese School  
(Barker Road)

Marking Scheme  
Secondary 1 Express  
Mathematics Paper 1  
End of Examination 2021

1	(a)	0.1419			
	(b)	0.142			
2		$\frac{60 \times 9}{3}$ 180			
3		$5x - 9y$			
4		$7a(1 - 3y)$			
5		$0.75\%$ , $0.57$ , $\frac{3}{5}$ , $\frac{\pi}{4}$ , $\frac{\sqrt{3}}{2}$			
6	(a)	2, 5			
	(b)	1, 2, 5, $\frac{22}{7}$			
7		Area = $7 \times 4 = 28 \text{ cm}^2$ $BF = \frac{28}{5} = 5.6 \text{ cm}$			
8					

9		<p>Let <math>x</math> be the price in 2018            Price in 2019 = <math>1.09x</math>            Price in 2020 = <math>0.91(1.09)x = 0.9919x</math>            Jim is wrong.</p>			
10	(a)	$\frac{72 \times 1000}{60 \times 60}$ $= 20 \text{ m/s}$			
	(b)	<p>50 g = 0.05 kg            0.05 kg costs \$<math>x</math>.  <math>y</math> kg costs \$ <math>\frac{yx}{0.05}</math>            = \$<math>20xy</math></p>			
11		<p>Original      7:9            New ratio    3:4                              6:8</p> <p>Since both have spent one part/unit from original,  <math>\Rightarrow</math> 1 part/unit = \$50            Total = <math>7+9 = 16</math> units            Total amount at beginning = <math>16 \times \\$50 = \\$800</math></p>			
12		<p>Area of WXYZ = <math>28 \times 28 = 784 \text{ cm}^2</math>            Area of small square = <math>14 \times 14 = 196 \text{ cm}^2</math>            (4 quarter circles and 4 semi-circles form 3 circles)            Area of the circles = <math>3 \times \frac{22}{7} \times 7 \times 7 = 462 \text{ cm}^2</math></p> <p>Area of the shaded part = <math>784 - 196 - 462 = 126 \text{ cm}^2</math>            Percentage of shaded part to unshaded part  <math>= \frac{126}{784 - 126} \times 100\%</math>  <math>= 19\frac{7}{47}\%</math></p>			
13	(a)	11			
	(b)	<p>Let the number be <math>n</math>.  <math display="block">\frac{32}{n+3} = 8</math> <math display="block">32 = 8n + 24</math> <math display="block">n = 1</math></p>			



Anglo-Chinese School  
(Barker Road)

Marking Scheme  
Secondary 1 Express  
Mathematics Paper 1  
End of Examination 2021

14		<p>Construction (refer behind)</p> <p><math>90^\circ \pm 3^\circ</math> <math>9.6 \text{ cm} \pm 0.2 \text{ cm}</math></p>		
15	(a)	<p>Angle <math>BCD = 43^\circ</math> (corresponding angles, <math>BC \parallel FD</math>) Angle <math>BDF = 57^\circ</math> (alternate angles, <math>BC \parallel FD</math>) Or Angle <math>BDC = (180 - 43 - 57) = 80^\circ</math> Angle <math>BDF = (180 - 80 - 43) = 57^\circ</math> (adjacent angles on a straight line)</p> <p>(b) angle <math>ABD = 180 - (43 + 57) = 80^\circ</math> angle <math>AFD = 360 - 99 - 57 - 80 = 124^\circ</math></p> <p>(b) Disagree <b>because</b> angle <math>FAB +</math> angle <math>ABD</math> is not equal to <math>180^\circ</math> (converse, interior opposite angles)</p>		
16	(a)	<p>\$80</p> <p>(b) \$40, 15 hours \$2</p> <p>(c)</p> <p>(d) 10 hours</p>		

Marking Scheme  
Secondary 1 Express  
Mathematics Paper 2  
End-of-Year Examination 2021

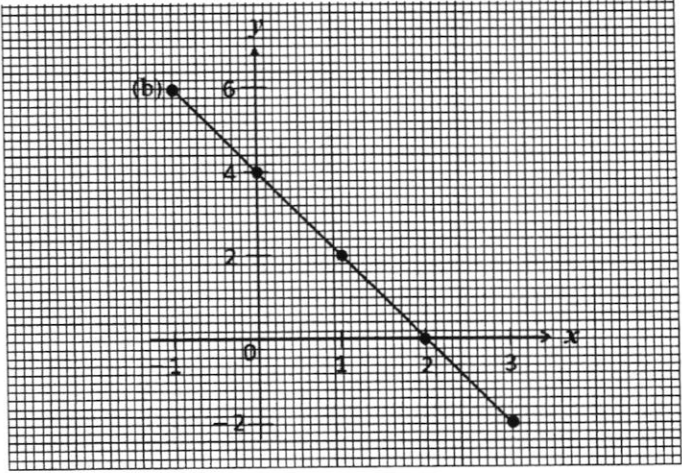
1	(a)	$90 = 2 \times 3^2 \times 5$ $156 = 2^2 \times 3 \times 13$			
	(b)	LCM = 2340			
	(c)	$\frac{2^2 \times 3 \times 13}{3 \times 13} = 2^2$ $k = 3 \times 13 = 39$			
	(d)	$156 = 2^2 \times 3 \times 13$ $26 = 2 \times 13$ $x = 2 \times 13 \times 5 = 130$			
2	(a)	2			
	(b)				
	(c)	(2, 0)			
	(d)	$x = 2.5$			



Anglo-Chinese School  
(Barker Road)

Marking Scheme  
Secondary 1 Express  
Mathematics Paper 2  
End-of-Year Examination 2021

3	(a)	Number of circles: $1 + 4 + 4 + 4 + 4 + 4 = 21$ Number of unshaded circles: 17			
	(b)	$1 + 4n$			
	(c)	For any value of $n$ , $4n$ will always be even. Adding and even number to 1 will always give an odd number. Hence the number of circles in the sequence will always be odd.			
	(d)	$(1 + 4n) - 4 = 178$ $4n = 181$ $n = 45.25$ No, there will not be a pattern.			
4	(a)	$\frac{(10-2) \times 180}{10}$ $144^\circ$			
	(b)	$\frac{360}{10} = 36^\circ$			
	(c)	angle $BAC = \frac{180-144}{2} = 18^\circ$ angle $CAJ = 144 - 18 = 126^\circ$			
5	(a)	$\frac{1}{2}(3+9)(4) = 24 \text{ cm}^2$			
	(b)	$24 \times 7 = 168$			
	(c)	$5 \times 7 \times 2 = 70 \text{ cm}^2$ $(3 \times 7) + (9 \times 7) = 84 \text{ cm}^2$ Total surface area = $(24 \times 2) + 84 + 70 = 202 \text{ cm}^2$ <u>Or</u> $(3 + 5 + 9 + 5) \times 7 = 154 \text{ cm}^2$ $24 \times 2 = 48 \text{ cm}^2$ Total surface area = $154 + 48 = 202 \text{ cm}^2$			

Marking Scheme  
Secondary 1 Express  
Mathematics Paper 2  
End-of-Year Examination 2021

6	(a)	(i)	$\frac{x}{70}$									
	(b)	(ii)	$\frac{x+45}{85}$									
	(c)		$\frac{x}{70} = \frac{x+45}{85}$ $85x = 70x + 3150$ $15x = 3150$ $x = 210$									
	(d)		Total distance travelled = $210 + (210 + 45) = 465$ km									
7	(a)	(i)	$\text{HKD } 1 = \frac{1}{100} \times 17.1850 = \text{SGD } 0.171850$ $\text{HKD } 350 = \text{SGD } (350 \times 0.171850) = \text{SGD } 60.15$									
		(ii)	<table style="width: 100%; border-collapse: collapse;"> <tr> <td style="width: 50%; vertical-align: top;"> <p><u>Method 1</u> Cost of bag in SGD = <math>294.35 \times \frac{100}{101.5}</math></p> <p>= SGD 290</p> <p>Cost in AUD = <math>290 \div 0.9848 = 294.48</math></p> <p>= 294</p> </td> <td style="width: 5%; text-align: center; vertical-align: middle;">M1</td> <td style="width: 45%; vertical-align: top;"> <p><u>Method 2</u></p> <p>Total amount paid in AUD = <math>294.35 \div 0.9848</math></p> <p>= 298.89</p> <p>Cost in AUD = <math>298.89 \times \frac{100}{101.5}</math></p> <p>= 294.47</p> </td> </tr> <tr> <td></td> <td style="text-align: center;">A1</td> <td>= 294</td> </tr> </table>	<p><u>Method 1</u> Cost of bag in SGD = <math>294.35 \times \frac{100}{101.5}</math></p> <p>= SGD 290</p> <p>Cost in AUD = <math>290 \div 0.9848 = 294.48</math></p> <p>= 294</p>	M1	<p><u>Method 2</u></p> <p>Total amount paid in AUD = <math>294.35 \div 0.9848</math></p> <p>= 298.89</p> <p>Cost in AUD = <math>298.89 \times \frac{100}{101.5}</math></p> <p>= 294.47</p>		A1	= 294			
<p><u>Method 1</u> Cost of bag in SGD = <math>294.35 \times \frac{100}{101.5}</math></p> <p>= SGD 290</p> <p>Cost in AUD = <math>290 \div 0.9848 = 294.48</math></p> <p>= 294</p>	M1	<p><u>Method 2</u></p> <p>Total amount paid in AUD = <math>294.35 \div 0.9848</math></p> <p>= 298.89</p> <p>Cost in AUD = <math>298.89 \times \frac{100}{101.5}</math></p> <p>= 294.47</p>										
	A1	= 294										
	(b)		$3120 = P + \frac{P(2)(2)}{100}$ $312000 = 100P + 4P$ $P = 312000 \div 104 = \$3000$									



Anglo-Chinese School  
(Barker Road)

Marking Scheme  
Secondary 1 Express  
Mathematics Paper 2  
End-of-Year Examination 2021

8	(a)	(i)	(6, 3)			
		(ii)	$\left(\frac{1}{2} \times 6 \times 3\right) = 9$ $9 \times 2 = 18$			
		(iii)	Kite			
	(b)	(i)	Gradient = $\frac{4}{3}$			
		(ii)	$y = \frac{4}{3}x + 3$			
9	(a)					
	(b)					