

Visit

FREETESTPAPER.com

for more papers



Website: [freetestpaper.com](http://www.freetestpaper.com)



[Facebook.com/freetestpaper](https://www.facebook.com/freetestpaper)



[Twitter.com/freetestpaper](https://www.twitter.com/freetestpaper)

Register No.	Class

Name : _____



BENDEMEER SECONDARY SCHOOL
2021 END OF YEAR EXAMINATION
SECONDARY 1 EXPRESS
Mathematics Paper 1

DATE : 08 October 2021
DURATION : 1 hour 15 mins
TOTAL : 50 Marks

READ THESE INSTRUCTIONS FIRST

Write your name, class and register number on all the work you hand in.
 Write in dark blue or black pen on both sides of the paper.
 You may use a 2B pencil for any diagrams or graphs.
 Do not use staples, paper clips, highlighters, glue or correction fluid/tape.
 Calculators are allowed for this paper.

Answer **all** questions.
 Write your answers in the spaces provided on the question paper.
 All the diagrams in this paper are **not** drawn to scale.
 If working is needed for any question, it must be shown with the answer.
 Omission of essential working will result in loss of marks.
 The use of an approved scientific calculator is expected, where appropriate.
 If the degree of accuracy is not specified in the question, and if the answer is not exact, give the answer to three significant figures. Give answers in degrees to one decimal place.
 For π , use either your calculator value or 3.142, unless the question requires the answer in terms of π .
 At the end of the examination, fasten all your work securely together.
 The number of marks is given in brackets [] at the end of each question or part question.

FOR EXAMINER'S USE
50

This document consists of **13** printed pages including this cover page.

[Turn over

Answer **all** the questions.

1. (a) Which of the following numbers are irrational
 $1.\dot{3}$, -1.5 , π , $\sqrt{2}$, -4

Answer : (a) [1]

- (b) Arrange the numbers above in **ascending** order.

Answer : (b) [1]

2. (a) Express $43\frac{2}{3}\%$ as a decimal.

Answer : (a) [1]

- (b) Given that $\frac{m}{4} = \frac{2n}{3}$, find the ratio $m : n$.

Answer : (b) [2]

3. (a) Expand and simplify the following expression

$$3c(2d - 5) - 5(c + 3)$$

Answer : (a) [2]

- (b) Factorise completely

$$\pi r^2 + 2\pi r h + \pi r l$$

Answer : (b) [1]

4. (a) Write the algebraic expression for “The sum of x and y divided by 2 times of x ”.
Give your expression in fraction form.

Answer : (a) [1]

- (b) Evaluate $\frac{\pi - 2x}{\sqrt[3]{5y^2}}$ when $x = -5$ and $y = 4$.

Answer : (b) [2]

5. (a) Express the following as a fraction in its simplest form.

$$2 + \frac{1}{4}(12x - 8)$$

Answer : (a) [2]

- (b) Solve the following equation,

$$\frac{5x}{3} - \frac{2x-3}{2} = -1$$

Answer : (b) $x =$ [3]

6. Each of the term in this sequence is found by adding the same number to the previous term.

19, a , 33, 40,

- (a) Find the value of a ,

Answer : (a) $a = \dots\dots\dots$ [1]

- (b) Find an expression, in terms of n , for the n^{th} term of the sequence,

Answer : (b) $\dots\dots\dots$ [1]

- (c) Determine if 117 is a term of this sequence.
Justify your answer with working. [2]

Answer (c):

7. (a) $\sqrt{5\frac{1}{16}}$ can be expressed as the rational number $\frac{p}{q}$ where p and q are positive integers. Find the values of p and q .

Answer : (a) $p = \dots\dots\dots$ $q = \dots\dots\dots$ [1]

- (b) The number of people in a theatre is given as 500, correct to the nearest hundred. Write down the minimum number of people that could be in the theatre at this time.

Answer : (b) $\dots\dots\dots$ [1]

8. The ratio of the amount of money that Jenny has to that of Lucy is 1 : 2 and the ratio of the amount of money that Lucy has to that of Ivy is 5 : 3.

Given that the total sum of money of the three ladies is \$63x, how much money does Ivy have in terms of x ?

Answer : \$ $\dots\dots\dots$ [3]

9. (a) (i) Express 168 as the product of prime factors.

Answer : (a) (i) [1]

- (ii) Find the smallest integer, k , such that $168k$ is a perfect square.

Answer : (a) (ii) $k =$ [1]

- (b) Given that $324 = 2^2 \times 3^4$, find the largest integer which is a factor of 168 and 324.

Answer : (b) [1]

10. A closed cylinder with base radius 5 cm has a volume of $300\pi \text{ cm}^3$.

Find

(a) the height of the cylinder,

Answer : (a) cm. [1]

(b) the total surface area of the cylinder.

Answer : (b) cm^2 [2]

11. In the figure below, $ED \parallel BC$, $DC \parallel FABG$, $\angle EDC = 116^\circ$ and $\angle EAF = 44^\circ$.

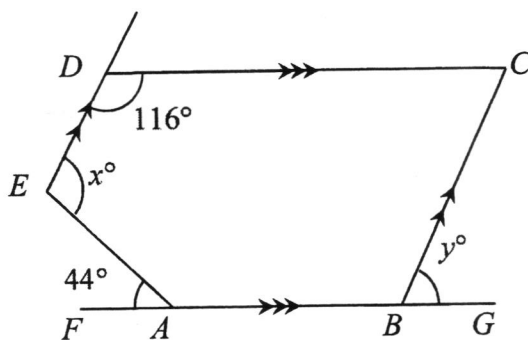

Stating **reasons** clearly, calculate

- (a) $\angle x$,

Answer : (a) [3]

- (b) $\angle y$.

Answer : (b) [1]

12. The diagram shows a regular pentagon, $ABCDE$ and three of the sides, GE , ED and DF , of a second regular polygon.
 Given that angle $CDF = 96^\circ$,

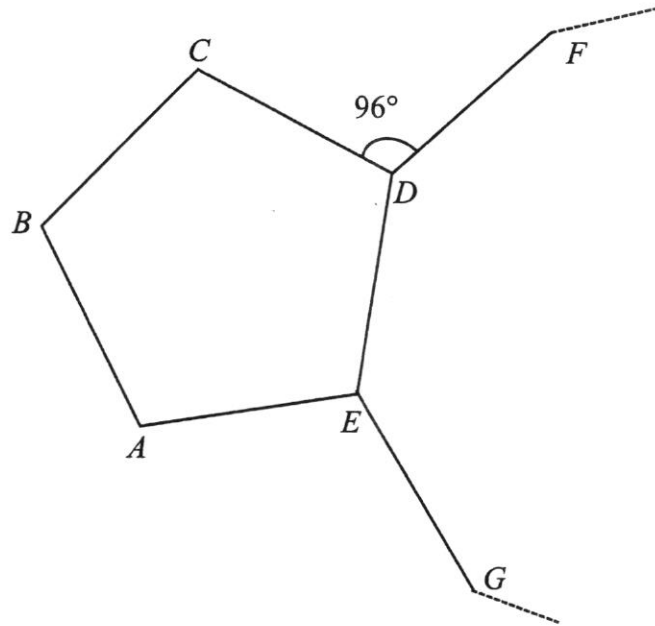

- (a) Find
 (i) $\angle CDE$,

Answer : (a) (i) $^\circ$ [2]

- (ii) $\angle EDF$,

Answer : (a) (ii) $^\circ$ [1]

- (b) Hence, find the number of sides in the second regular polygon.

Answer : (b) [2]

13. (a) An airplane leaves Country A at 09 00 local time.
The distance between Country A to Country B is 5407.5 km.
The average speed of the airplane is 721 km/h.
The airplane arrives in Country B at 15 00 local time.

Find the time difference between Country A and Country B , stating whether the time in Country B is ahead or behind the time in Country A .
Show your working clearly.

Answer : (a) [3]

- (b) A car travels at 72 km/h.
Convert the speed to metres per second.

Answer : (b) [2]

14. The graph below shows two straight lines L_1 and L_2 .

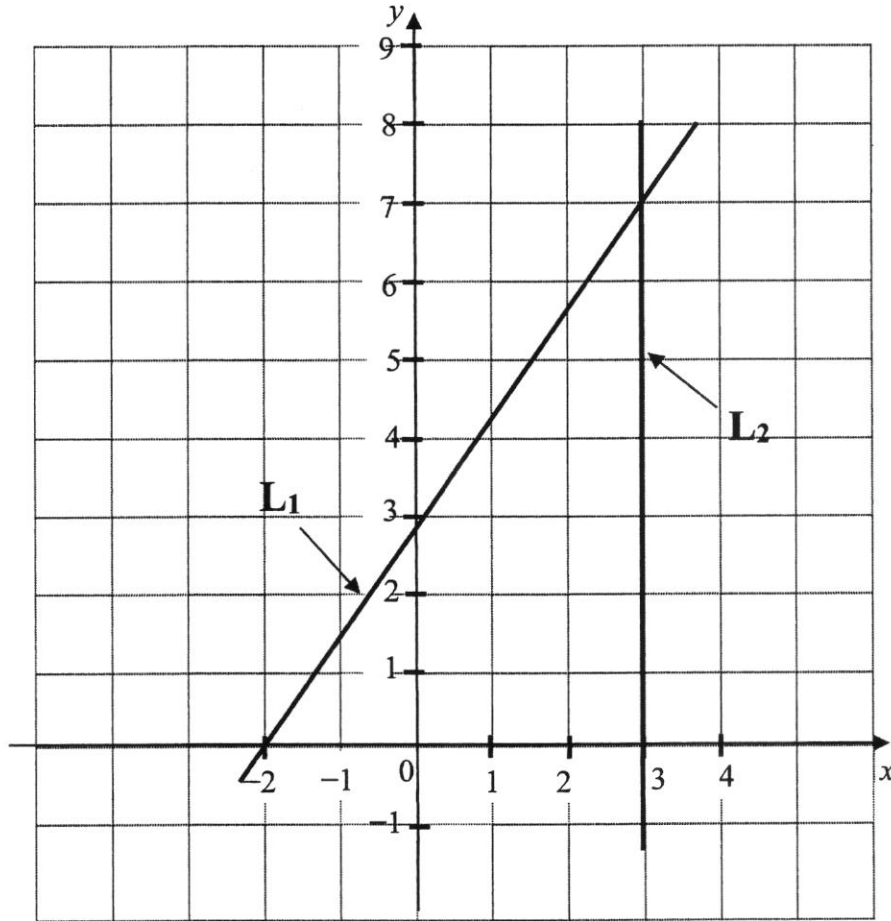

(a) Write down the equation of L_2 .

Answer : (a) [1]

(b) Calculate the area enclosed by the line L_1 , the line L_2 and the x -axis

Answer : (b)square units [2]

- (c) (i) If the gradient for the line L_1 increases, describe how the new straight line differs from the original straight line.

Answer : (i)
.....
..... [1]

- (ii) Jane wants to draw a new line with the same gradient as line L_1 , She claimed that the new line and L_1 will meet at the origin. Explain whether you agree or disagree with her.

Answer : (ii)
.....
..... [1]

End of Paper 1

Register No.	Class

Name : _____



BENDEMEER SECONDARY SCHOOL
2021 END OF YEAR EXAMINATION
SECONDARY 1 EXPRESS
Mathematics Paper 2

DATE : 11 October 2021
DURATION : 1 hour 15 minutes
TOTAL : 50 Marks

READ THESE INSTRUCTIONS FIRST

Write your name, class and register number on all the work you hand in.
 Write in dark blue or black pen on both sides of the paper.
 You may use a 2B pencil for any diagrams or graphs.
 Do not use staples, paper clips, highlighters, glue or correction fluid/tape.

Answer **all** questions.

Write your answers in the spaces provided on the question paper.

All the diagrams in this paper are **not** drawn to scale.

If working is needed for any question, it must be shown with the answer.

Omission of essential working will result in loss of marks.

The use of an approved scientific calculator is expected, where appropriate.

If the degree of accuracy is not specified in the question, and if the answer is not exact, give the answer to three significant figures. Give answers in degrees to one decimal place.

For π , use either your calculator value or 3.142, unless the question requires the answer in terms of π .

At the end of the examination, fasten all your work securely together.

The number of marks is given in brackets [] at the end of each question or part question.

FOR EXAMINER'S USE
50

This document consists of **11** printed pages including this cover page.

[Turn over

Answer **all** the questions.

1. (a) Solve the following equation

$$x - [3 - 2(5x - 0.5)] = 18$$

Answer: (a) [2]

- (b) Simplify $\frac{8p+16}{4} \times \frac{1}{2}$

Answer: (b) [2]

- (c) Factorise $3a(3 + b) + 5(ab + a)$

Answer: (c) [2]

2. (a) Mr Koh borrows \$30 000 from a bank on 1st January 2021 to renovate his house. The bank charges simple interest at a rate of 2.6% per annum. Calculate the amount of interest he has to pay at the end of December 2025.

Answer: (a) \$ [2]

- (b) Mr Koh decides to travel from Singapore to Taiwan for a holiday. The following shows the exchange rate in Singapore and Taiwan:

Exchange rate in Singapore	Exchange rate in Taiwan
1 Singapore Dollar = 20.516 Taiwan dollars	100 Taiwan Dollars = 4.874 Singapore dollars

Mr Koh wants to exchange 1000 Singapore dollars to Taiwan dollars. Determine how much more Taiwan dollars he will receive by changing his money in Taiwan. Give your answer to the nearest cents.

Answer: (b) Taiwan dollars [3]

3. In the diagram, $ABCD$ is a parallelogram with $\angle DAB = 72^\circ$.
 DCE , HCF and BCG are straight lines.
 $\angle GCF = 22^\circ$, $\angle DCH = y^\circ$ and $\angle AHC = z^\circ$

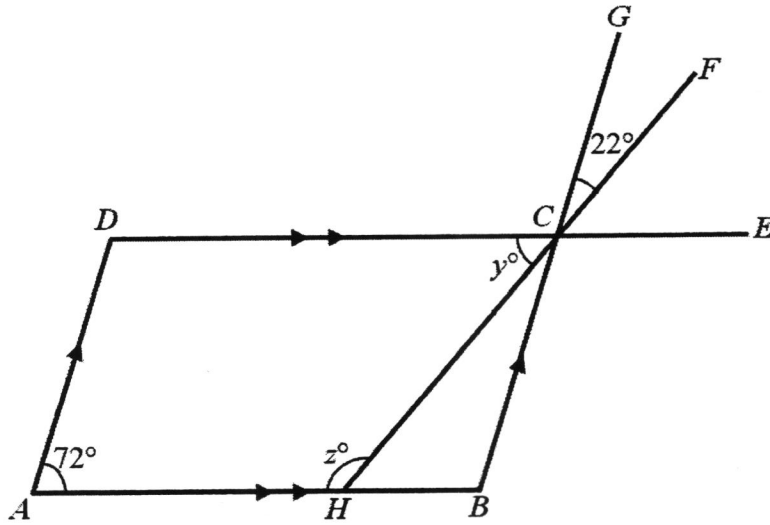

Find, giving reasons for your workings,

- (i) y ,

Answer: (i) $^\circ$ [2]

- (ii) z .

Answer: (ii) $^\circ$ [2]

4. The figure below shows a parallelogram $PQRS$ and two identical semi-circles with radius 2 cm.
 Given that QU is perpendicular to PS , $QU = 8x$ cm, $PQ = (4x - 2)$ cm and $PS = 6$ cm.

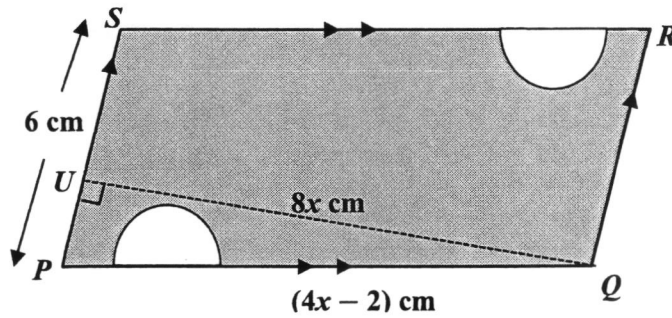

- (i) Find and simplify the area of the parallelogram $PQRS$ in terms of x ,

Answer: (i)..... cm^2 [2]

- (ii) Calculate the total area of the two semi-circles and leave your answer in terms of π ,

Answer: (ii) cm^2 [1]

- (iii) Hence, find the area of the shaded region in terms of x and π .

Answer: (iii) cm^2 [1]

5. The table below shows some values of x and the corresponding values of y .

x	-4	0	4
y	14	6	-2

- (a) Using a scale of 2 cm to 1 unit, draw a horizontal x -axis from -4 to 4 and a scale of 1 cm to 1 unit, draw a vertical y -axis from -2 to 14 on the grid on page 7.

On the same axes, plot the points given in the above table and join them with a straight line. [3]

- (b) Use your graph in (a) to find
(i) the gradient of the line,

Answer: (b)(i) [1]

- (ii) y -intercept,

Answer: (b)(ii) [1]

- (iii) the equation of the line in the form of $y = mx + c$.

Answer: (b)(iii) [1]

- (c) The points $(-1.5, p)$ and $(q, 1)$ lie on the graph in (a).
From your graph, find the value of

- (i) p ,

Answer: (c)(i) $p =$ [1]

- (ii) q .

Answer: (c)(ii) $q =$ [1]

Answer for part (a)

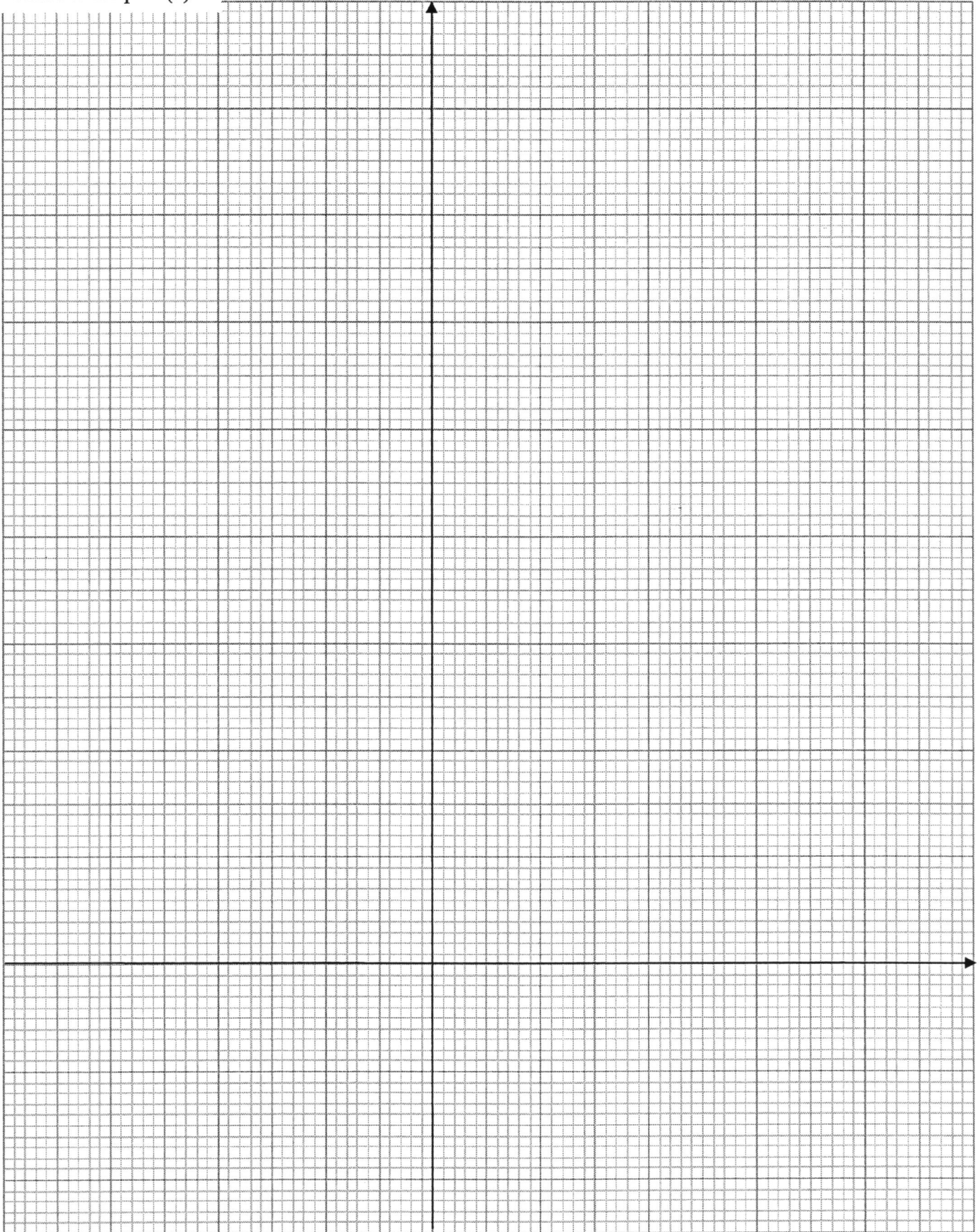

6. Mrs Yap and Mrs Chin estimate that they will take 5 hours and 6 hours respectively to finish marking the same pile of books individually.

If they mark the same pile of books together, the estimated time taken is x hours.

- (a) (i) What fraction of the pile of books can Mrs Yap finish marking in 1 hour?

Answer: (a)(i) [1]

- (ii) What fraction of the pile of books can Mrs Chin finish marking in 1 hour?

Answer: (a)(ii) [1]

- (iii) What fraction of the same pile of books can both of them finish marking in 1 hour if they mark together?

Answer: (a)(iii) [1]

- (b) Hence, form an equation in terms of x and solve for the unknown.

Answer: (b) h [2]

7. The following figure shows the cross section view of a swimming pool. The swimming pool is **100 m long and 40 m wide**. The bottom of the pool slopes uniformly throughout the length of the pool. It is 1.75 m deep at the shallow end and 3 m deep at the deep end. The depth of water at the shallow end is 1 m.

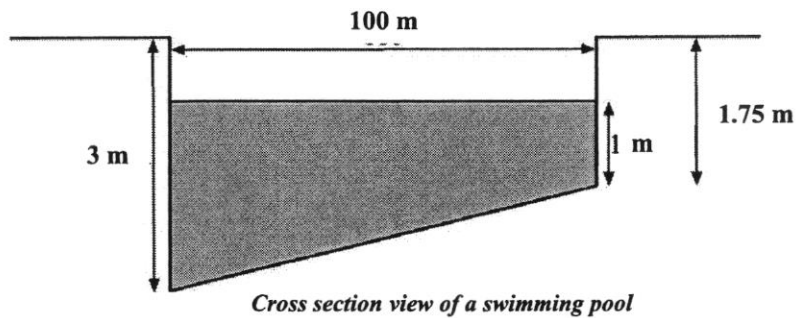

- (a) Find the volume of water in the pool to the nearest cubic metre.

Answer: (a) m^3 [3]

- (b) How much more water must be poured into the pool to fill it completely?

Answer: (b) m^3 [2]

- (c) It takes 30 seconds to drain 10 m^3 of water. Find the total time, in hours and minutes, needed to drain a fully filled pool.

Answer: (c) h mins [3]

8. In June 2021, prices of durians in Singapore dropped significantly as the hot weather conditions in Malaysia helped in harvesting of more durians. More durians were then imported in Singapore.

Prices of durians were at \$30 per kilogram in May 2021, but it dropped to \$24 per kilogram in June 2021.

- (a) Calculate the percentage drop in price per kilogram from May to June 2021.

Answer: (a) % [2]

- (b) Durian vendor Mr Lim imported 1000 kg of durians from Malaysia each day.

Assuming that all 1000 kg of durians were sold each day, calculate

- (i) the difference in earnings per day after the drop in prices,

Answer: (b)(i) \$ [2]

- (ii) the cost price per kilogram of durians given that Mr Lim still made a profit of \$3880 daily after the drop in prices.

Answer: (b)(ii) \$ [2]

(c) In July 2021, due to the increase in the community cases of COVID-19 in Singapore, Heightened Alert was implemented to tighten the community measures and the daily sales of Mr Lim's stall was affected.

In order to help to sell all his 1000 kg of the imported durians, Mr Lim decided to carry out the following promotion:

**For every 5 kg sold at \$24 per kilogram,
customer will get 1kg worth of durians
FREE!**



Determine if Mr Lim will make a loss or a profit daily if he sold 1000 kg of durians with all his customers maximising the deal and calculate the daily profit or loss with this promotion.

Answer: (c) Mr Lim will make a daily **loss / profit** (*Circle if there is a loss or profit*)

of \$ [4]

End of Paper

2021 1E Paper 1 Marking Scheme

1(a)	$\pi, \sqrt{2}$	A1
1(b)	$-4, -1.5, 1.\dot{3}, \sqrt{2}, \pi$	A1
2(a)	0.433 (3 sf)	A1
2b)	$\frac{m}{4} = \frac{2n}{3}$ $\frac{m}{n} = \frac{8}{3}$ $m : n = 8 : 3$	M1 A1
3(a)	$3c(2d - 5) - 5(c + 3)$ $= 6cd - 15c - 5c - 15$ $= 6cd - 20c - 15$	M1 A1
3(b)	$\pi r^2 + 2\pi r h + \pi r l$ $= (\pi r)(r + 2h + l)$	A1
4(a)	$\frac{x + y}{2x}$	A1
4(b)	when $x = -5$ and $y = 4$, $\frac{\pi - 2x}{\sqrt[3]{5y^2}} = \frac{\pi - 2(-5)}{\sqrt[3]{5(4)^2}}$ $= 3.05$	M1 A1
5(a)	$2 + \frac{1}{4}(12x - 8)$ $= 2 + 3x - 2$ $= 3x$	M1 A1
5(b)	$\frac{5x}{3} - \frac{2x - 3}{2} = -1$ $\frac{10x}{6} - \frac{6x - 9}{6} = -1$ $\frac{10x - 6x + 9}{6} = -1$ $4x + 9 = -6$ $x = \frac{-15}{4}$ $x = -3.75 \text{ or } -3\frac{3}{4}$	M1 M1 A1

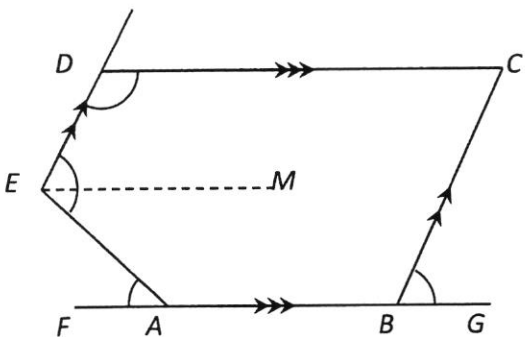
6(a)	26	A1
6(b)	$7n + 12$	A1
6(c)	$7n + 12 = 117$ $n = (117 - 12) \div 7$ $= 15$ Since n is an integer, it is a term in the sequence	M1 A1
7(a)	$p = 9, q = 4$	A1
7(b)	450	A1
8	Jenny : Lucy: Ivy $1 : 2$ <hr style="width: 10%; margin-left: 0;"/> $5 : 3$ $5 : 10 : 6$ 21 units ----- \$63x 6 units ----- $\$ \frac{6}{21} \times 63x = \$18x$ Ivy has \$18x	M1 M1 A1
9(a)(i)	$168 = 2^3 \times 3 \times 7$	A1
9(a)(ii)	$k = 42$	A1
9(b)	HCF = 12	A1
10 (a)	Height = $\frac{300\pi}{\pi(5^2)} = 12$ cm	A1
10(b)	Total surface area = $2\pi(5)(12) + 2\pi(5^2)$ $= 534$ cm ² (3sf)	M1 A1
11(a)	 <p> $\angle AEM = \angle EAF = 44^\circ$ (Alternate Angles, DC parallel to AG) $\angle DEM = 180^\circ - 116^\circ$ (Interior Angle, $DC \parallel EM$) $= 64^\circ$ $\angle x = 64^\circ + 44^\circ$ $= 108^\circ$ </p>	M1 M1 A1
11(b)	$\angle y = 64^\circ$ (Corresponding Angles, $ED \parallel BC$)	A1

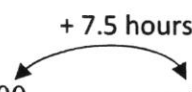
12(a)(i)	$\angle CDE = \frac{(5-2) \times 180^\circ}{5}$ $= 108^\circ$	M1 A1
12(a)(ii)	$\angle EDF = 360^\circ - 108^\circ - 96^\circ$ $= 156^\circ$	A1
12(b)	Ext angle of the second polygon = 24° Number of sides = $\frac{360}{24} = 15$	M1 A1
13(a)	$\text{Time taken} = \frac{5407.5}{721}$ $= 7.5 \text{ hrs}$ <p> Arrival time at country A 09 00 = 16 30 Arrival time at country B = 15 00 Country B is behind by 1.5 hours </p> 	M1 M1 A1
13(b)	$72 \text{ km/h} = \frac{72 \text{ km}}{1 \text{ h}}$ $= \frac{72 \times 1000 \text{ m}}{1 \times 3600 \text{ s}}$ $= 20 \text{ m/s}$	M1 A1
14(a)	$x = 3$	A1
14(b)	$\text{Area} = \frac{1}{2} \times 5 \times 7$ $= 17.5 \text{ units}$	M1 A1
14(c)(i)	The new straight line will be steeper than the original line.	A1
14(c)(ii)	Disagree. Because if the two line have the same gradient, then the two lines are parallel to each other so they will not meet each other. Or: Disagree. Because the original line L_1 does not pass through the origin so it will never meet the new line at the origin.	A1

2021 1E Paper 2 Marking Scheme

1(a)	$x - [3 - 2(5x - 0.5)] = 18$ $x - [3 - 10x + 1] = 18$ $x - [4 - 10x] = 18$ $x - 4 + 10x = 18$ $11x = 18 + 4$ $x = 2$	M1 A1
1(b)	$\frac{8p + 16}{4} \times \frac{1}{2}$ $= \frac{8p+16}{8}$ $= p + 2$	M1 A1
1(c)	$3a(3 + b) + 5(ab + a)$ $= 9a + 3ab + 5ab + 5a$ $= 14a + 8ab$ $= (2a)(7 + 4b)$	M1 A1
2(a)	<p>Total amount of interest paid = $\left[\frac{2.6}{100} \times 30\,000\right] \times 5$</p> <p style="text-align: center;">= \$3900</p>	M1 A1
2(b)	<p>In Singapore</p> <p>1 Singapore Dollar ----- 20.516 Taiwan Dollars 1000 Singapore Dollars ----- 1000 x 20.516 = 20516 Taiwan Dollars</p> <p>In Taiwan,</p> <p>4.874 Singapore Dollars ----- 100 Taiwan Dollars 1000 Singapore Dollars ----- $\frac{1000}{4.874} \times 100$ = 20517.03 Taiwan Dollars</p> <p>Extra Taiwan Dollars he receives in Taiwan = 20517.03 – 20516 = 1.03 Taiwan Dollars</p>	M1 M1 A1

3(i)	$\angle HCB = 22^\circ$ (vert. opp. \angle s) $\angle DCB = 72^\circ$ (opp. \angle s of //gram) or (Property of //gram) $y = 72^\circ - 22^\circ$ $= 50^\circ$	Reasoning: M1 Answer: A1	
3(ii)	$z = 180 - 50$ (int. \angle s, DE//AB) $= 130^\circ$	Reasoning: M1 Answer: A1	
4(i)	Area of Parallelogram = $(6)(8x)$ $= 48x \text{ cm}^2$		M1 A1
4(ii)	Area of 2 semi-circles = $\pi(2)^2 = 4\pi \text{ cm}^2$		A1
4(iii)	Area of shaded region = $48x - 4\pi \text{ cm}^2$		A1
5(a)	See attached graph Scale for each axis : M2 Points and Join up the points to get the straight line: M1		
5(b)(i)	Gradient = -2		A1
5(b)(ii)	y-intercept = 6		A1
5(b)(iii)	$y = -2x + 6$		A1
5(c)(i)	$p = 9$		A1
5(c)(ii)	$q = 2.5$		A1
6(ai)	$\frac{1}{5}$		A1
6(aii)	$\frac{1}{6}$		A1
6(aiii)	$\frac{1}{x}$ or $\frac{11}{30}$		A1
6(b)	$\frac{1}{5} + \frac{1}{6} = \frac{1}{x}$ $\frac{6}{30} + \frac{5}{30} = \frac{1}{x}$ $\frac{11}{30} = \frac{1}{x}$ $x = 2\frac{8}{11}$ hour	Or $\frac{11}{30} = \frac{1}{x}$ $x = 2\frac{8}{11}$	M1 A1

7(a)	$\text{Height} = 1.75 - 1 = 0.75 \text{ m}$ $\text{Vol of water} = \frac{1}{2} \left((1+3) - 0.75 \right) \times 100 \times 40$ $= 162.5 \times 40$ $= 6500 \text{ m}^3$	M1 M1 A1
7(b)	$\text{Volume of water to be poured} = 100 \times 40 \times 0.75$ $= 4000 \times 0.75$ $= 3000 \text{ m}^3$	M1 A1
7(c)	$\text{Total volume of fully filled pool} = 3000 + 6500$ $= 9500 \text{ m}^3$ $\text{Time taken to drain fully filled pool} = \frac{9500}{10} \times 60$ $= 28500 \text{ seconds}$ $= 7 \text{ h } 55 \text{ min}$	M1 M1 A1

8(a)	Percentage fall in price $= \frac{30-24}{30} \times 100\%$ $= 20\%$	M1 A1
8(b)(i)	Difference in price per kg $= \$30 - \$24 = \$6$ Difference in earning $= 1000 \times \$6$ $= \$6000$	M1 A1
8(b)(ii)	Profit per kg of durians $= 3880 \div 1000 = \$3.88$ Cost Price per kg $= \text{Selling price per kg} - \text{profit per kg}$ $= \$24 - \3.88 $= \$20.12$	M1 A1
7(c)	<p>6 kg ----- $\\$5 \times 24 = \\120 Only 166 customers ($166 \times 6 \text{ kg} = 996\text{kg}$) can get 6kg by maximizing the deal. There will be another 4kg that do not enjoy the promotion.</p> <p>So, 996kg ----- $(996/6) \times 120 = \\$19920$ The other 4 kg without promotion $= \\$24 \times 4 = \\96 Total selling price with promotion $= \\$19920 + \\$96 = \\$20016$</p> <p>Total cost $= 1000 \times 20.12 = \\$20120$</p> <p>Total daily loss $= 20016 - 20120 = \\$104$</p> <p>Also accept:</p> <p>Total Selling Price of 5 kg of durians $= 5 \times 24$ $= \\$120$ A customer will get 6 kg of durians for \$120</p> <p>Selling price per kg with the promotion $= 120 \div 6$ $= \\$20$</p> <p>Cost price per kg $= \\$20.12$ So the loss per kg $= 20.12 - 20$ $= \\$0.12$</p> <p>Total daily loss $= 1000 \times 0.12 = \\$120$ He will make a daily loss of \$120</p>	M1 M1 M1 A1 M1 M1 A1

Also accept: 6 kg ----- $\$5 \times 24 = \120 1000kg ----- $(1000/6) \times 120 = \$20000$ Total selling price with promotion = \$20000	M1 M1
Total cost = $1000 \times 20.12 = \$20120$	M1
Total daily loss = $20120 - 20000 = \$120$	A1