

Visit

FREETESTPAPER.com

for more papers



Website: [freetestpaper.com](http://www.freetestpaper.com)



[Facebook.com/freetestpaper](https://www.facebook.com/freetestpaper)



[Twitter.com/freetestpaper](https://www.twitter.com/freetestpaper)



PRESBYTERIAN HIGH SCHOOL
2021 END-OF-YEAR EXAMINATION
SECONDARY ONE EXPRESS
MATHEMATICS (4052)

Name: _____ () Class: 1 _____

Duration: 2 hours 30 minutes

Date: 6 Oct 2021

DO NOT OPEN THIS QUESTION PAPER UNTIL YOU ARE TOLD TO DO SO.

INSTRUCTIONS TO CANDIDATES:

This paper consists of Section A and Section B.

Write your name, index number and class on the cover pages of **Section A** and **Section B**.

Write in dark blue or black ink pen. You may use a soft pencil for any diagrams or graphs.

Do not use staples, paper clips, highlighters, glue or correction fluid.

Answer **all** questions.

Write your answers on the spaces provided below the questions.

Omission of essential working will result in loss of marks.
 Calculators should be used where appropriate.

INFORMATION FOR CANDIDATES:

If the degree of accuracy is not specified in the question, and if the answer is not exact, give the answer to three significant figures.

For π , use either your calculator value or 3.142, unless the question requires the answer in terms of π .

You are reminded of the need for clear presentation in your answers.

The number of marks is given in brackets [] at the end of each question or part question.

The total number of marks for **Section A** and **Section B** is **50** each.

Setter: Mr Wong Shao Mun
 Vetter: Mdm Chung Bee Chee

For Examiner's Use	
Section A	50

This paper consists of **12** printed pages (including this cover page) and **0** blank pages.

Section A (50 marks)
Answer ALL questions.

- 1 The table below gives information on the number of applications received for two primary schools.

Complete the table.

School	Number of applications	Number of vacancies	Ratio of applications to vacancies
Delta Primary	45	15	3 : 1
Echo Primary	28	7	

[1]

- 2 (a) Express 0.021 38 correct to 2 significant figures.

Answer [1]

- (b) The number of students in a school hall is given as 200, correct to the nearest hundred.

Write down the maximum number of students that could be in the school hall at that time.

Answer [1]

- 3 $y = 3x + 2$ $y = 3x - 2$ $y = -3x + 2$ $y = -3x - 2$

The diagrams below show sketches of two of these lines.

Write the correct equation below each diagram.

Answer

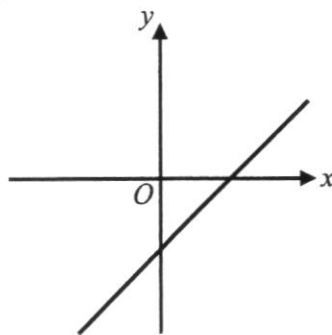

.....

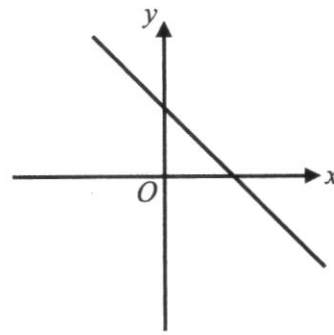

.....

[2]

- 4 Find the square root of $3^2 \times 5^4$ without using a calculator. **Show your steps clearly.**

Answer [2]

5

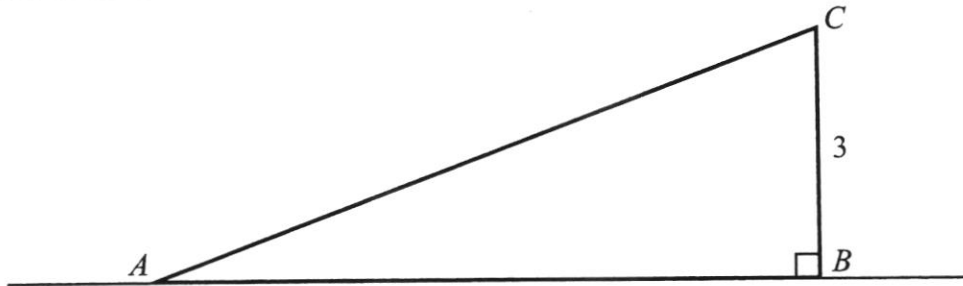

A slide in the shape of the triangle ABC lies on the ground.

$BC = 3$ m.

The area of triangle ABC is 7.8 m².

Find AB .

Answer m [2]

6 It is given that $D = b^2 - 4ac$.

Find the value of

(a) D when $b = -3$, $a = 1$ and $c = -2$.

Answer $D = \dots\dots\dots$ [1]

(b) c when $D = 3$, $b = 7$ and $a = 5$.

Answer $c = \dots\dots\dots$ [2]

7 Consider these four numbers,

$$-0.\dot{3}$$

$$\frac{\pi}{2}$$

$$-2\sqrt{2}$$

$$\frac{7}{2}$$

(a) write down the irrational number(s),

Answer $\dots\dots\dots$ [1]

(b) represent the four numbers on the below number line.

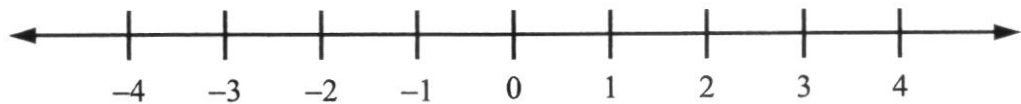

[2]

- 8 (a) Factorise $3de + 9d^2$ completely.

Answer [1]

- (b) Simplify $2 \times m \times v + mv + 1$.

Answer [2]

- 9 $ABCD$ is a quadrilateral.

$BC = 7$ cm, $\angle ABC = 110^\circ$, $AD = 9$ cm and $\angle BAD = 75^\circ$.

AB is drawn below.

Answer (a)



- (a) With the help of a pair of compasses, protractor and ruler, construct the quadrilateral $ABCD$. [2]

- (b) Measure length CD .

Answer cm [1]

- 10 (a) Express the following as a single fraction in its simplest form.

$$\frac{x+1}{4} - \frac{1-2x}{3}$$

Answer [2]

- (b) Solve $5y - 13 = 3y + 8$.

Answer $y =$ [2]

- 11 (a) A ceiling has an area of $120\,000\text{ cm}^2$.
Convert $120\,000\text{ cm}^2$ to m^2 .

Answer m^2 [2]

- (b) 1 litre of paint covers 16 m^2 .
Calculate the amount of paint needed to paint 11.2 m^2 .

Answer l [2]

12

Not to scale

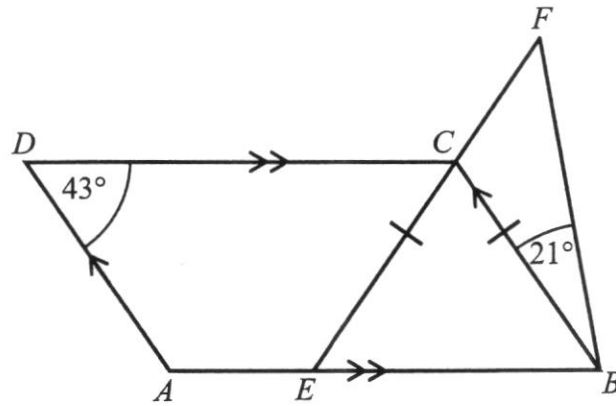

ABCD is a parallelogram.
ECF and *BF* are straight lines.
 $CE = CB$, $\angle ADC = 43^\circ$ and $\angle CBF = 21^\circ$.
E is a point on *AB*.

Stating your reasons clearly, find $\angle EFB$.

Answer $\angle EFB = \dots\dots\dots^\circ$ [4]

- 13 Straight lines AB and DE are drawn on the grid.

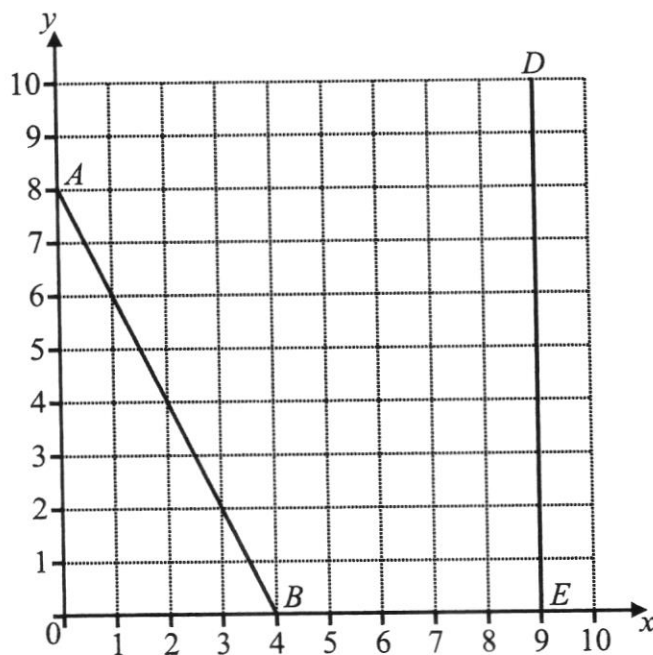

- (a) Find the gradient of the line AB .

Answer [1]

- (b) Write down the equation of the line AB .

Answer [1]

- (c) Point C lies in the middle of line AB .
Write down the coordinates of point C .

Answer (..... ,) [1]

- (d) Write down the equation of the line DE .

Answer [1]

[Turn over

- 14 The diagram shows a circle, centre O .
 AD is the diameter of the circle.
 The area of the circle is $9.9225\pi \text{ cm}^2$.
 $ABCD$ is a rectangle.
 E is a point on BC such that it touches the circle.

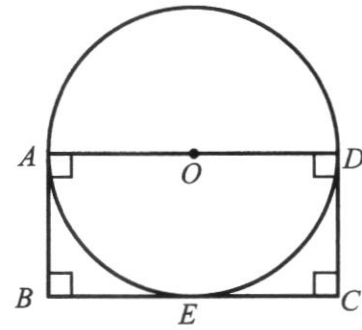

- (a) Show that the radius of the circle is 3.15 cm.

[2]

- (b) Calculate the perimeter of $ABCD$.

Answer cm [2]

- 15 The following table of values is for a straight line $y = -5x + 4$.

x	-1	0	3
y	p	4	-11

- (a) Find the value of p .

Answer $p =$ [1]

- (b) On the grid on the next page, draw the graph of $y = -5x + 4$ for the range $-1 \leq x \leq 3$.

[2]

- (c) Using your graph, find the value of x when $y = -4.5$.
 Mark your working clearly on the grid.

Answer $x =$ [1]

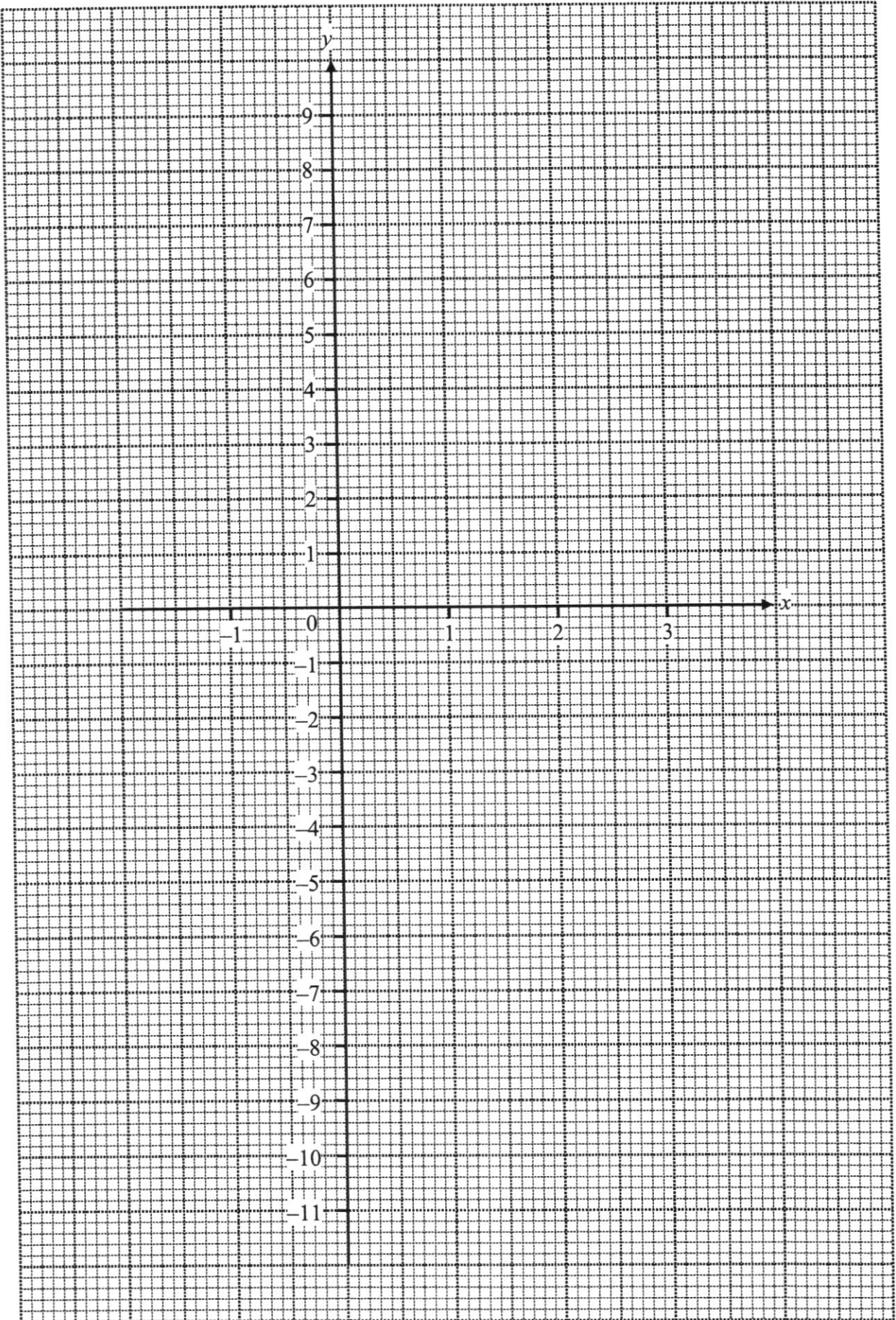

[Turn over

- 16 (a) In the diagram, AB is parallel to DE .
 $\angle ABC = 128^\circ$ and $\angle EDF = 13^\circ$.
 Stating your reasons clearly, find $\angle BCD$.

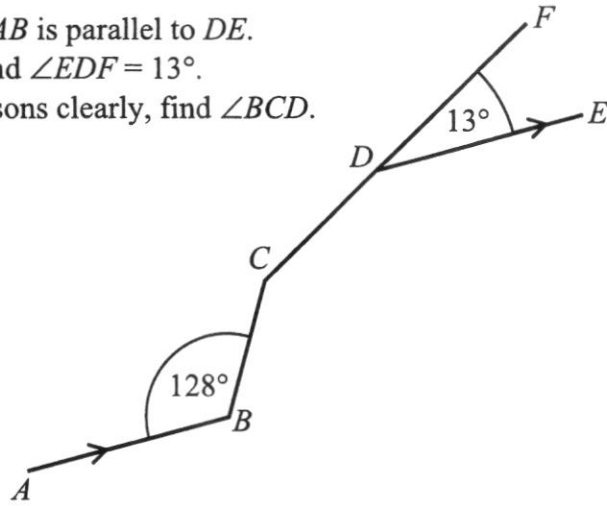

Not to scale

Answer $\angle BCD = \dots\dots\dots^\circ$ [3]

- (b)

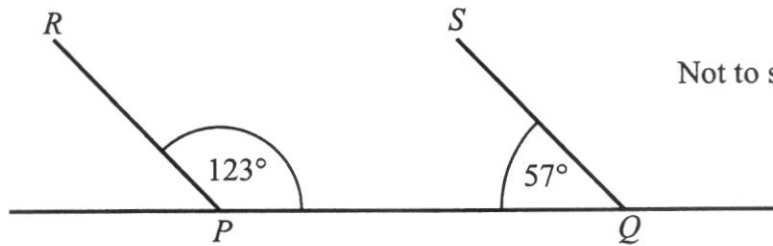

Not to scale

Drone P and drone Q are launched from the ground in the direction of R and S respectively.
 Stating your reasons clearly, explain whether their flight paths will cross one another.

.....
 [2]

END OF SECTION A



PRESBYTERIAN HIGH SCHOOL
2021 END-OF-YEAR EXAMINATION
SECONDARY ONE EXPRESS
MATHEMATICS (4052)

Name: _____ () Class: 1 _____

Section B

<i>For Examiner's Use</i>											
Qn	17	18	19	20	21	22	23	24			<i>Marks Deducted</i>
Marks											

Category	Accuracy	Symbols	Others
Question No.			

Setter: Mr Wong Shao Mun
 Vetter: Mdm Chung Bee Chee

<i>For Examiner's Use</i>	
Section B	50

This paper consists of **12** printed pages (including this cover page) and **0** blank pages.

Section B (50 marks)
Answer ALL questions.

- 17 The pie chart shows the categories of online videos watched by a group of people.

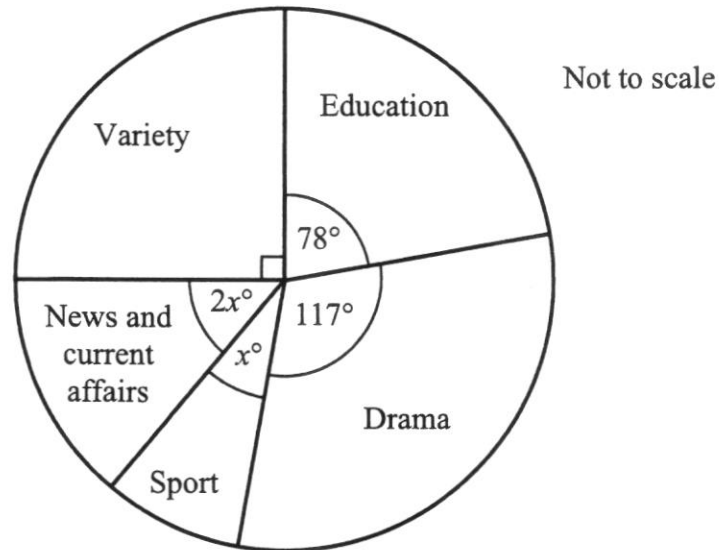

- (a) Calculate the value of x .

Answer $x =$ [2]

- (b) Calculate the percentage of people that watched drama.

Answer% [1]

- (c) If 195 more people watched drama than education, find the total number of people in the group.

Answer people [2]

18

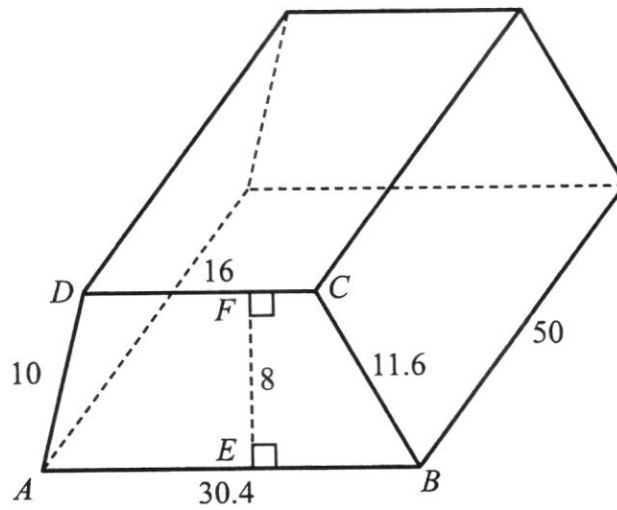

The diagram shows a prism whose cross-section is a trapezium, $ABCD$.
 $AB = 30.4$ cm, $BC = 11.6$ cm, $CD = 16$ cm, $AD = 10$ cm and $EF = 8$ cm.
 The length of the prism is 50 cm.

Calculate the

- (a) volume of the prism,

Answer cm^3 [2]

- (b) surface area of the prism.

Answer cm^2 [3]

- 19 (a) A shirt costs \$18 after a 20% discount. Find its original price.

Answer \$..... [2]

- (b) Chris deposits \$6000 in a savings account at a simple interest rate of 1.2% per annum.

- (i) Calculate the total interest earned in 3 years.

Answer \$..... [2]

- (ii) If he wants to earn a total interest of \$360, how long should the \$6000 be deposited?

Answer years [2]

20 The first three terms in a sequence of numbers, T_1, T_2, T_3, \dots are given below.

$$T_1 = 3 + 4(1) = 7$$

$$T_2 = 3 + 4(2) = 11$$

$$T_3 = 3 + 4(3) = 15$$

(a) (i) Find T_7 .

Answer $T_7 = \dots\dots\dots$ [1]

(ii) Find an expression, in terms of n , for T_n .

Answer $T_n = \dots\dots\dots$ [1]

(iii) Explain why 165 is not a term of this sequence.

Answer

[1]

(b) Solve $\frac{2x-1}{3x+2} = \frac{4}{13}$.

Answer $x = \dots\dots\dots$ [3]

[Turn over

- 21 The bar graph shows the monthly number of customers who visited a shop from June to September.



- (a) Calculate the monthly average of customers who visited the shop.

Answer [2]

- (b) Calculate the percentage increase in the number of customers from August to September.

Answer% [2]

- (c) Another bar graph shows the monthly sales of computers from October to November.

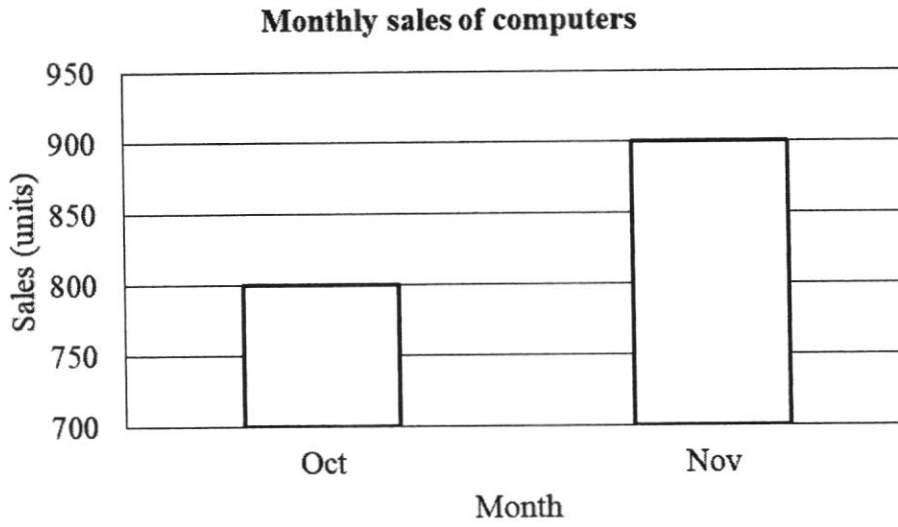

‘The number of computers sold in November is twice the number of computers sold in October.’

Explain why this statement is wrong.

.....

.....

.....

..... [2]

- 22 (a) Convert 72 km/h to m/s.

Answer m/s [2]

- (b) Daphne runs 6 km in 0.5 hour and rests for 0.25 hour.
Calculate the average speed for the whole journey.

Answer km/h [2]

- (c) Three buses leave a bus interchange at regular intervals. Bus *A* leaves every 5 minutes, Bus *B* leaves every 8 minutes and Bus *C* leaves every 34 minutes. All three buses leave the interchange together at 6 am.
When will the three buses next leave together again?

Answer [3]

23 (a)

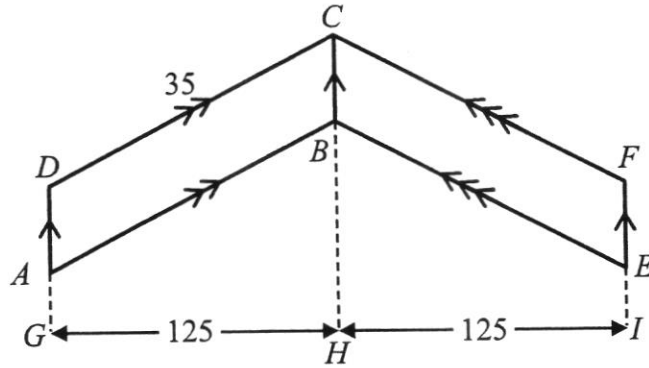

$ABEFCD$ is made up of two identical parallelograms, $ABCD$ and $BEFC$.
 $CD = 35$ cm and $GH = HI = 125$ cm.
 The perimeter of one parallelogram is 110 cm.

Calculate

(i) AD ,

Answer cm [2]

(ii) area of $ABEFCD$.

Answer cm^2 [2]

(b)

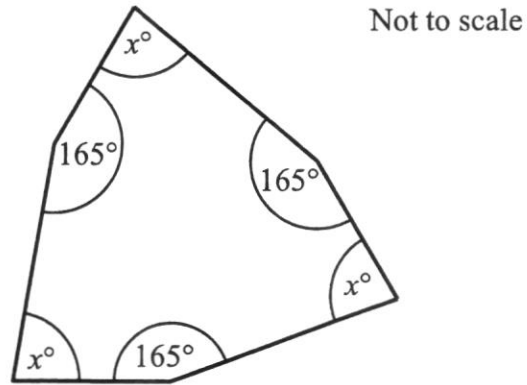

The diagram shows a hexagon.

Find the value of x .

Answer $x =$ [3]

(c) The angles of a quadrilateral are measured and recorded as below.

Measurement	W	X	Y	Z
Interior angle	91°	48°	114°	108°
Exterior angle	89°	132°	67°	72°

Identify which pair of measurement is wrong and explain why.

Measurement is wrong because

..... [1]

24 Below is some information about electricity use.

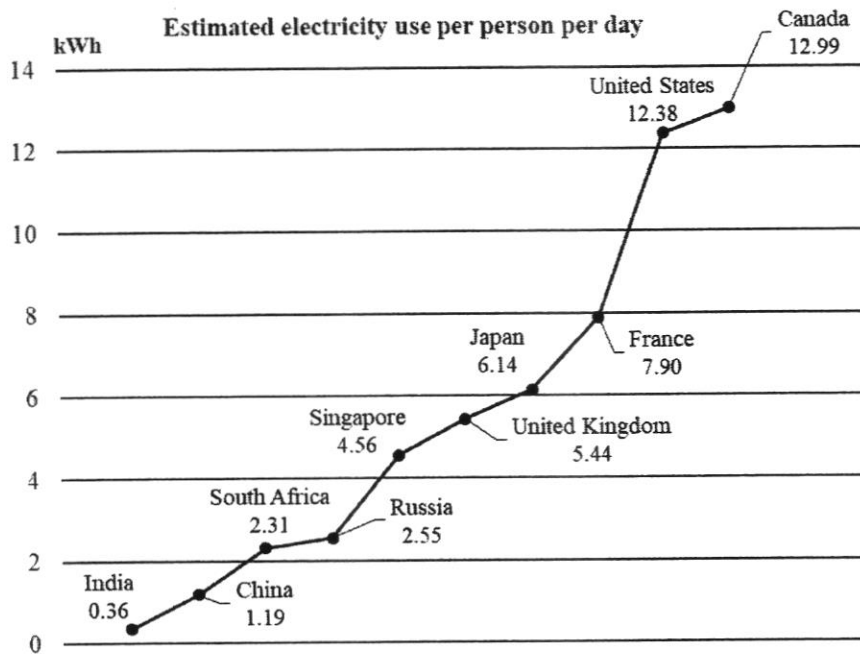

Percentage breakdown of electricity use for appliances in a typical Singapore household

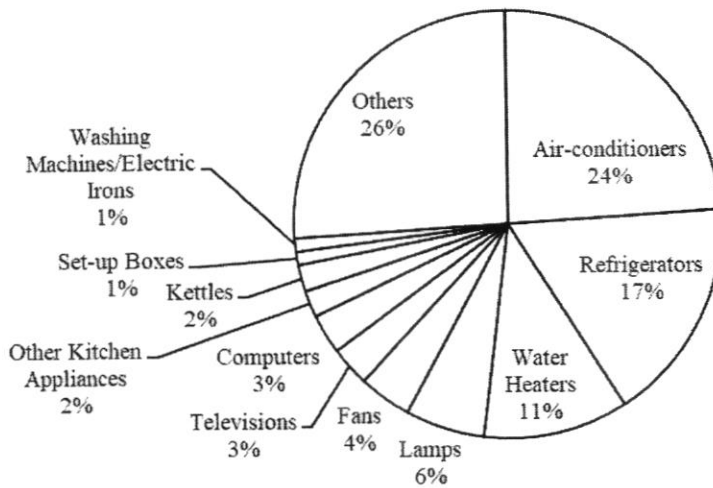

(a) In Singapore, what is the estimated electricity use per person per day for water heaters?

Answer kWh [2]

[Turn over

- (b) (i) Find the total electricity use per day for a typical Singapore household of 4 people.

Answer kWh [2]

- (ii) There are 4 people in the Tan family.
The percentage of electricity they use for air-conditioners is the same as the percentage for a typical Singapore household.
The Tan family uses an average of 19 kWh of electricity per day.

Mr Tan claims that if each person in the family reduces their air-conditioning use time from 8 hours to 6 hours, the family can get their total electricity use to below that of a typical Singapore household of 4 people.

Is Mr Tan correct?
Explain your answer.

Answer

[3]

END OF SECTION B



PRESBYTERIAN HIGH SCHOOL
2021 END-OF-YEAR EXAMINATION
SECONDARY ONE EXPRESS
MATHEMATICS (4052)

Name: _____ () Class: 1 _____

Duration: 2 hours 30 minutes

Date: 6 Oct 2021

DO NOT OPEN THIS QUESTION PAPER UNTIL YOU ARE TOLD TO DO SO.

INSTRUCTIONS TO CANDIDATES:

This paper consists of Section A and Section B.

Write your name, index number and class on the cover pages of **Section A** and **Section B**.

Write in dark blue or black ink pen. You may use a soft pencil for any diagrams or graphs.

Do not use staples, paper clips, highlighters, glue or correction fluid.

Answer **all** questions.

Write your answers on the spaces provided below the questions.

Omission of essential working will result in loss of marks.

Calculators should be used where appropriate.

INFORMATION FOR CANDIDATES:

If the degree of accuracy is not specified in the question, and if the answer is not exact, give the answer to three significant figures.

For π , use either your calculator value or 3.142, unless the question requires the answer in terms of π .

You are reminded of the need for clear presentation in your answers.

The number of marks is given in brackets [] at the end of each question or part question.

The total number of marks for **Section A** and **Section B** is **50** each.

Setter: Mr Wong Shao Mun
 Vetter: Mdm Chung Bee Chee

For Examiner's Use	
Section A	50

This paper consists of **12** printed pages (including this cover page) and **0** blank pages.

Section A (50 marks)
Answer ALL questions.

- 1** The table below gives information on the number of applications received for two primary schools.
AO2

Complete the table.

School	Number of applications	Number of vacancies	Ratio of applications to vacancies
Delta Primary	45	15	3 : 1
Echo Primary	28	7	4 : 1 B1

[1]

- 2** (a) Express 0.021 38 correct to 2 significant figures.
AO1

Answer 0.021 **B1** [1]

- (b) The number of students in a school hall is given as 200, correct to the nearest hundred.
AO2

Write down the maximum number of students that could be in the school hall at that time.

Answer 249 **B1** [1]

3
AO2

$y = 3x + 2$	$y = 3x - 2$	$y = -3x + 2$	$y = -3x - 2$
--------------	--------------	---------------	---------------

The diagrams below show sketches of two of these lines.

Write the correct equation below each diagram.

Answer

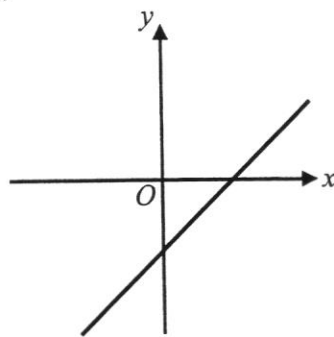

$y = 3x - 2$ **B1**
.....

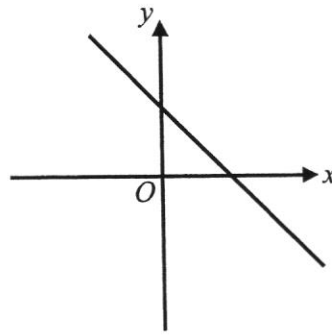

$y = -3x + 2$ **B1**
.....

[2]

4 Find the square root of $3^2 \times 5^4$ without using a calculator. Show your steps clearly.
AO1

Method 1:

$$3^2 \times 5^4 = (3 \times 5^2) \times (3 \times 5^2) \quad \text{M1: Factors correctly grouped into 2 groups.}$$

$$\sqrt{3^2 \times 5^4} = 3 \times 5^2 \quad \text{If above not seen, award M1 here if see this.}$$

$$\sqrt{3^2 \times 5^4} = 75$$

Method 2:

$$3^2 \times 5^4 = (3 \times 5^2)^2 \quad \text{M1: Factors correctly grouped into 2 groups.}$$

$$\sqrt{3^2 \times 5^4} = 3 \times 5^2 \quad \text{If above not seen, award M1 here if see this.}$$

$$\sqrt{3^2 \times 5^4} = 75$$

Answer 75 A1 [2]

5
AO2

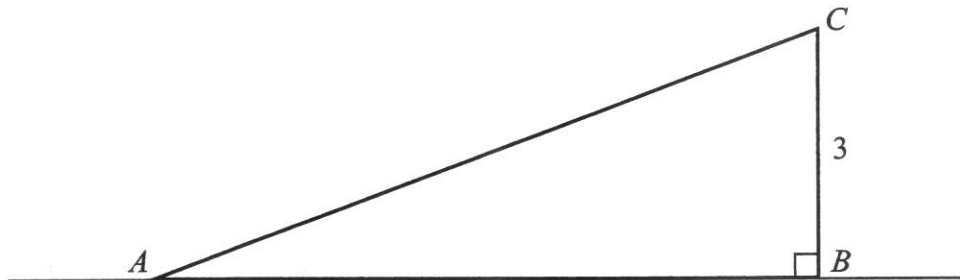

A slide in the shape of the triangle ABC lies on the ground.

$BC = 3$ m.

The area of triangle ABC is 7.8 m².

Find AB .

$$\frac{1}{2} \times AB \times 3 = 7.8 \quad \text{M1: Form equation.}$$

$$1.5AB = 7.8$$

$$\frac{1.5AB}{1.5} = \frac{7.8}{1.5}$$

$$AB = 5.2 \text{ m}$$

Answer 5.2 A1 m [2]

6 It is given that $D = b^2 - 4ac$.

Find the value of

(a) D when $b = -3$, $a = 1$ and $c = -2$.
AO1

$$\begin{aligned} D &= b^2 - 4ac \\ D &= (-3)^2 - 4(1)(-2) \\ D &= 17 \end{aligned}$$

Answer $D = \dots\dots\dots 17$ B1 [1]

(b) c when $D = 3$, $b = 7$ and $a = 5$.
AO1

$$\begin{aligned} D &= b^2 - 4ac \\ 3 &= (7)^2 - 4(5)c \quad \text{M1: Seen correct substitution.} \\ 3 &= 49 - 20c \\ 3 - 49 &= -20c \\ -46 &= -20c \\ \frac{-46}{-20} &= \frac{-20c}{-20} \\ 2.3 &= c \\ c &= 2.3 \end{aligned}$$

2.3 A1
Accept $2\frac{3}{10}$.
Answer $c = \dots\dots\dots$ [2]

7 Consider these four numbers,

$$-0.\dot{3} \qquad \frac{\pi}{2} \qquad -2\sqrt{2} \qquad \frac{7}{2}$$

(a) write down the irrational number(s),
AO1

$\frac{\pi}{2}, -2\sqrt{2}$ B1
Answer $\dots\dots\dots$ [1]

(b) represent the four numbers on the below number line.
AO1 B1 mark for every 2 correct answers. B1 mark for all 4 correct dots but above number line.
Each correct answer comprises of a B1 mark for all 4 correct dots but no label above dot.
solid dot and label.

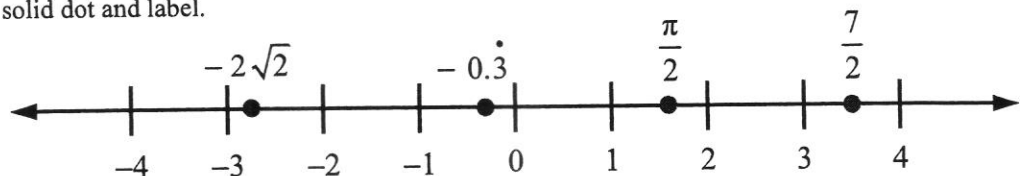

[2]

8 (a) Factorise $3de + 9d^2$ completely.

AO1

Answer $3d(e + 3d)$ **B1** [1]

(b) Simplify $2 \times m \times v + mv + 1$.

AO1

$$\begin{aligned} & 2 \times m \times v + mv + 1 \\ & = 2mv + mv + 1 \quad \mathbf{M1: \text{Seen } 2mv.} \\ & = 3mv + 1 \end{aligned}$$

Answer $3mv + 1$ **A1** [2]

9 $ABCD$ is a quadrilateral.

$BC = 7$ cm, $\angle ABC = 110^\circ$, $AD = 9$ cm and $\angle BAD = 75^\circ$.

AB is drawn below.

Answer (a)

Q9(a) B1 for length BC .

B1 for length AD .

Deduct one mark:

- if length CD is not drawn,
- for any missing arc or
- if vertex C or D is not labelled.
- if no overshoot for AD or BC .

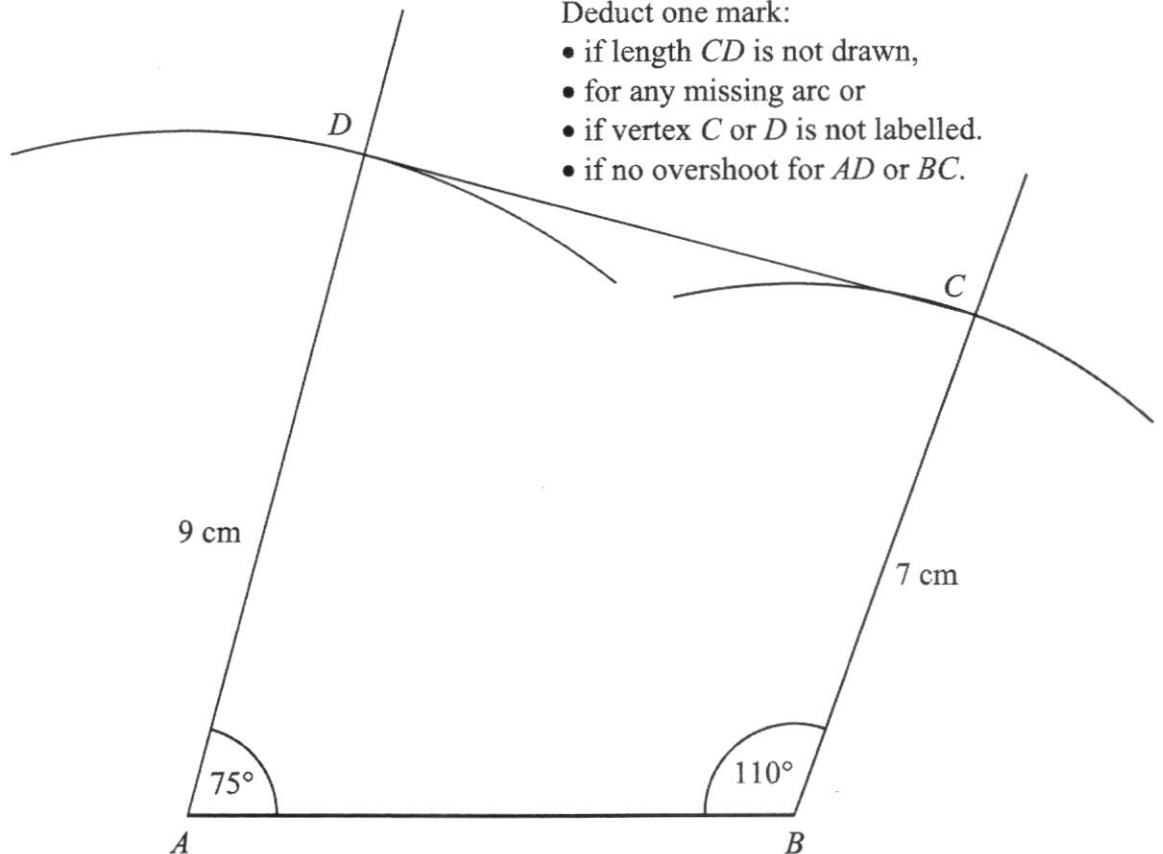

(a) With the help of a pair of compasses, protractor and ruler, construct the quadrilateral $ABCD$. [2]

AO1

(b)

AO1

Measure length CD . Note: General Office's printing machine in 2021 enlarged AB from 8 cm to 8.1 cm, thus CD is (8.4 ± 0.1) cm. If not, CD should have been (8.3 ± 0.1) cm.

Answer $8.4 \pm 0.1 = 8.3$ to 8.5 **B1** cm [1]

- 10 (a) Express the following as a single fraction in its simplest form.
AO1

$$\frac{x+1}{4} - \frac{1-2x}{3}$$

$$\begin{aligned} & \frac{x+1}{4} - \frac{1-2x}{3} \\ = & \frac{x+1}{4} \times \frac{3}{3} - \frac{1-2x}{3} \times \frac{4}{4} \quad \mathbf{M1:} \text{ Find common denominator.} \\ = & \frac{3(x+1) - 4(1-2x)}{12} \\ = & \frac{3x+3-4+8x}{12} \\ = & \frac{11x-1}{12} \end{aligned}$$

Answer $\frac{11x-1}{12}$ A1 [2]

- (b) Solve $5y - 13 = 3y + 8$.
AO1

$$\begin{aligned} 5y - 13 &= 3y + 8 \\ 5y - 3y &= 8 + 13 \quad \mathbf{M1:} \text{ Terms correctly collected on each side of equation.} \\ 2y &= 21 \\ \frac{2y}{2} &= \frac{21}{2} \\ y &= 10.5 \end{aligned}$$

10.5 A1
Accept $10\frac{1}{2}$.
Answer $y =$ [2]

- 11 (a)** A ceiling has an area of 120 000 cm².
AO1 Convert 120 000 cm² to m².

Method 1:

$$100 \text{ cm} \times 100 \text{ cm} = 1 \text{ m} \times 1 \text{ m}$$

$$10\,000 \text{ cm}^2 = 1 \text{ m}^2 \quad \mathbf{M1}$$

$$\frac{10\,000 \text{ cm}^2}{10\,000} = \frac{1 \text{ m}^2}{10\,000}$$

$$1 \text{ cm}^2 = \frac{1}{10\,000} \text{ m}^2$$

$$120\,000 \times 1 \text{ cm}^2 = 120\,000 \times \frac{1}{10\,000} \text{ m}^2$$

$$120\,000 \text{ cm}^2 = 12 \text{ m}^2$$

Method 2:

$$120\,000 \text{ cm}^2 = 120\,000 \times 1 \text{ cm} \times 1 \text{ cm}$$

$$120\,000 \text{ cm}^2 = 120\,000 \times \frac{1}{100} \text{ m} \times \frac{1}{100} \text{ m} \quad \mathbf{M1}$$

$$120\,000 \text{ cm}^2 = 12 \text{ m}^2$$

Method 3:

$$1 \text{ cm} \times 1 \text{ cm} = \frac{1}{100} \text{ m} \times \frac{1}{100} \text{ m}$$

$$1 \text{ cm}^2 = \frac{1}{10\,000} \text{ m}^2 \quad \mathbf{M1}$$

$$120\,000 \times 1 \text{ cm}^2 = 120\,000 \times \frac{1}{10\,000} \text{ m}^2$$

$$120\,000 \text{ cm}^2 = 12 \text{ m}^2$$

Answer 12 A1 m² [2]

- (b)** 1 litre of paint covers 16 m².
AO2 Calculate the amount of paint needed to paint 11.2 m².

Amount of paint needed

$$= \frac{11.2}{16} \quad \mathbf{M1}$$

$$= 0.7 \text{ l}$$

Answer 0.7 A1 l [2]

12
AO2

Not to scale

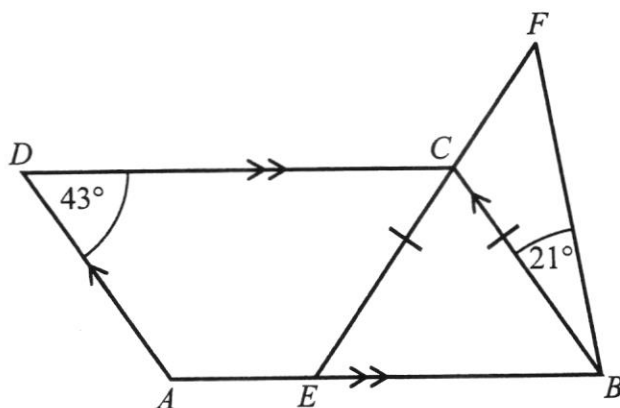

$ABCD$ is a parallelogram.
 ECF and BF are straight lines.
 $CE = CB$, $\angle ADC = 43^\circ$ and $\angle CBF = 21^\circ$.
 E is a point on AB .

Stating your reasons clearly, find $\angle EFB$.

$\angle EBC = 43^\circ$ (opp. \angle s of //gram) **M1**: Seen geometrical reason.

$\angle CEB = 43^\circ$ (base \angle s of isos. Δ) **M1**: Seen geometrical reason.

$\angle EFB = 180^\circ - 43^\circ - 43^\circ - 21^\circ$ (\angle sum of Δ) **M1**: Seen geometrical reason.

$\angle EFB = 73^\circ$

Deduct 1 mark for any missing/wrong geometrical reason from above three.

Deduct 1 mark for two or more non-standard geometrical reason from above three.

Answer $\angle EFB = 73$ **A1** $^\circ$ [4]

- 13 Straight lines AB and DE are drawn on the grid.

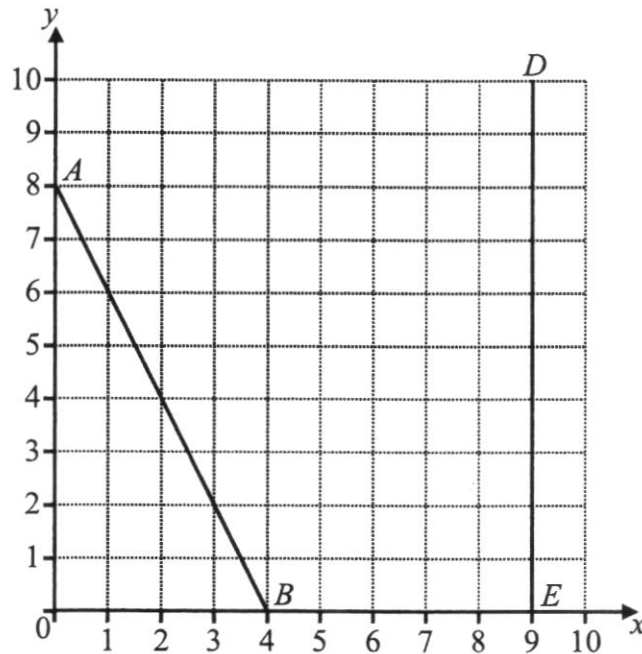

- (a) Find the gradient of the line AB .
AO2

$$\begin{aligned} & \text{Gradient} \\ &= \frac{\text{Vertical change}}{\text{Horizontal change}} \\ &= \frac{-8}{4} \\ &= -2 \end{aligned}$$

Answer -2 B1 [1]

- (b) Write down the equation of the line AB .
AO2

Answer $y = -2x + 8$ B1 [1]

- (c) Point C lies in the middle of line AB .
AO2 Write down the coordinates of point C .

Answer (..... 2 , 4) B1 [1]

- (d) Write down the equation of the line DE .
AO1

Answer $x = 9$ B1 [1]

- 14 The diagram shows a circle, centre O .
 AD is the diameter of the circle.
 The area of the circle is $9.9225\pi \text{ cm}^2$.
 $ABCD$ is a rectangle.
 E is a point on BC such that it touches the circle.

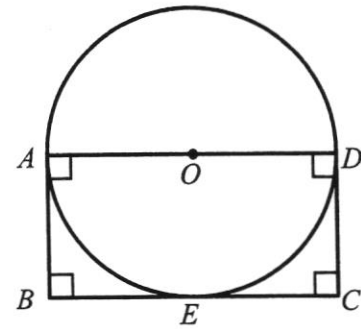

- (a) Show that the radius of the circle is 3.15 cm.
AO1

$$\begin{aligned} \pi r^2 &= 9.9225\pi \quad \mathbf{M1} \\ \frac{\pi r^2}{\pi} &= \frac{9.9225\pi}{\pi} \\ r^2 &= 9.9225 \\ r &= \sqrt{\quad} \\ r &= 3.15 \text{ cm (shown)} \quad \mathbf{A1} \end{aligned}$$

[2]

- (b) Calculate the perimeter of $ABCD$.
AO2

$$\begin{aligned} \text{Length of } ABCD &= 6(3.15) \quad \mathbf{M1} \\ &= 18.9 \text{ cm} \end{aligned}$$

Answer 18.9 **A1** cm [2]

- 15 The following table of values is for a straight line $y = -5x + 4$.

x	-1	0	3
y	p	4	-11

- (a) Find the value of p .
AO1

$$\begin{aligned} \text{When } x &= -1, \\ p &= -5x + 4 \\ p &= -5(-1) + 4 \\ p &= 9 \end{aligned}$$

Answer $p =$ 9 **B1** [1]

- (b) On the grid on the next page, draw the graph of $y = -5x + 4$ for the range $-1 \leq x \leq 3$.
AO1 [2]

- (c) Using your graph, find the value of x when $y = -4.5$.
AO1 Mark your working clearly on the grid. **B1:** Seen dotted line working and answer labelled on grid.

Answer $x =$ $1.7 \pm 0.05 = 1.65$ to 1.75 [1]

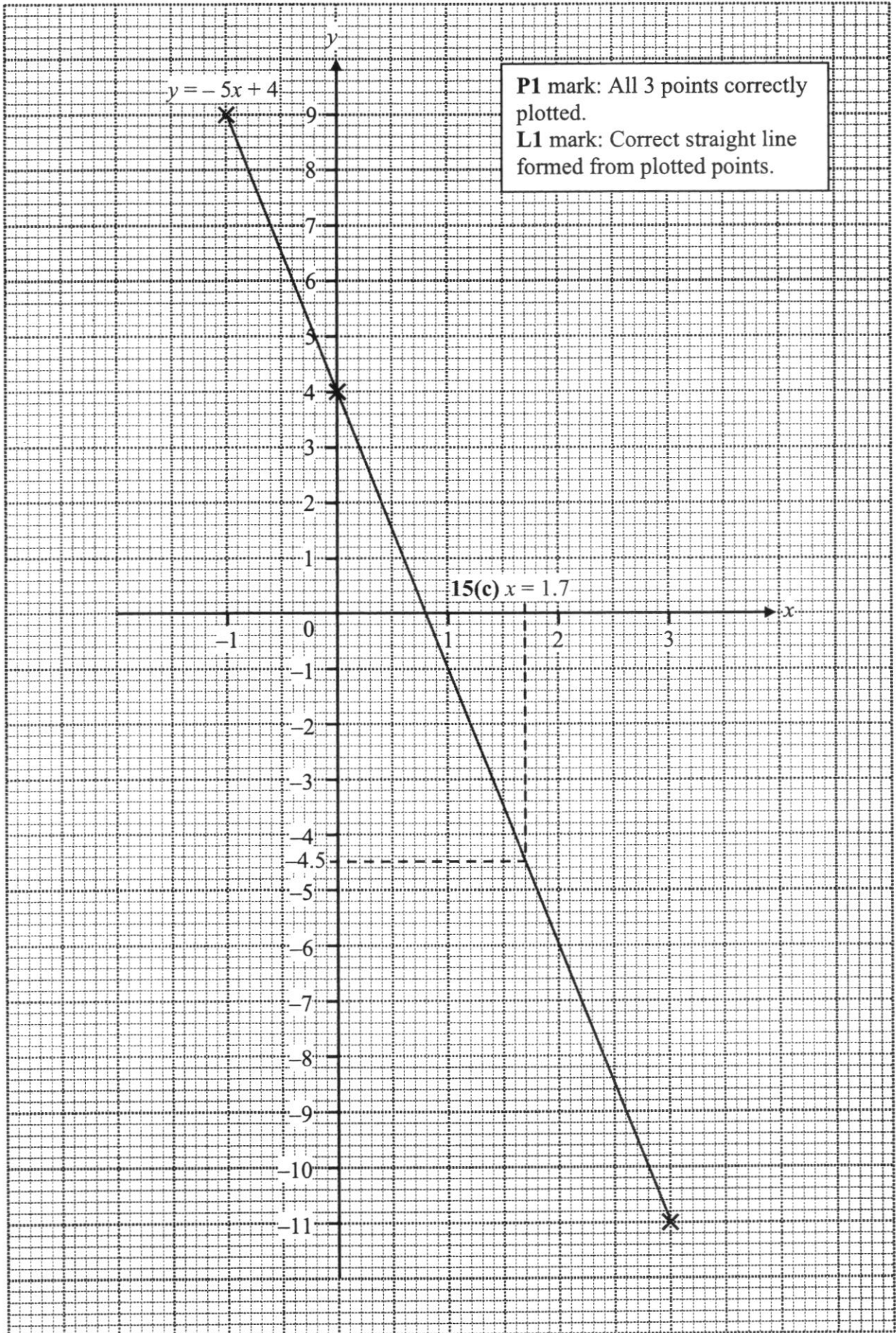

[Turn over

- 16 (a) In the diagram, AB is parallel to DE .
 AO2 $\angle ABC = 128^\circ$ and $\angle EDF = 13^\circ$.
 Stating your reasons clearly, find $\angle BCD$.

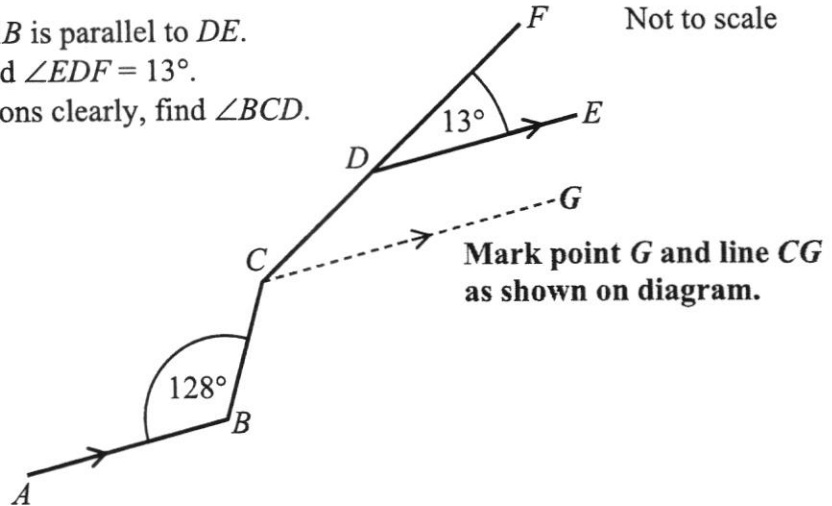

$\angle BCG = 128^\circ$ (alt. \angle s, $AB \parallel CG$) M1: Seen geometrical reason.

$\angle FCG = 13^\circ$ (corr. \angle s, $DE \parallel CG$) M1: Seen geometrical reason.

$\angle BCD = 128^\circ + 13^\circ$

$\angle BCD = 141^\circ$

Deduct 1 mark for any missing/wrong geometrical reason.

Answer $\angle BCD = \dots\dots\dots 141 \text{ A1} \dots\dots\dots^\circ$ [3]

- (b)
 AO3

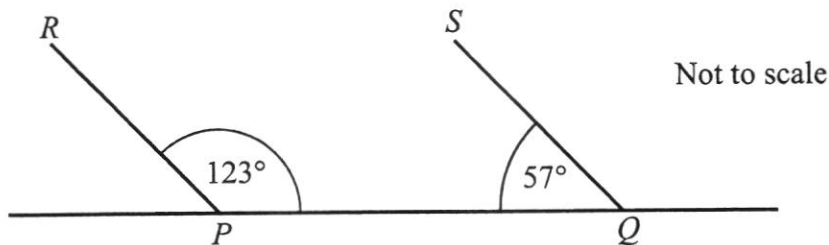

Drone P and drone Q are launched from the ground in the direction of R and S respectively.
 Stating your reasons clearly, explain whether their flight paths will cross one another.

Their flight paths will not cross one another because they are parallel [B1] as
 $\angle QPR + \angle PQS = 123^\circ + 57^\circ = 180^\circ$ (int. \angle s, $PR \parallel QS$). [B1: Seen geometrical reason.]
 [2]

END OF SECTION A



PRESBYTERIAN HIGH SCHOOL
2021 END-OF-YEAR EXAMINATION
SECONDARY ONE EXPRESS
MATHEMATICS (4052)

Name: _____ () Class: 1 _____

Section B

<i>For Examiner's Use</i>													
Qn	17	18	19	20	21	22	23	24					<i>Marks Deducted</i>
Marks													

Category	Accuracy	Symbols	Others
Question No.			

Setter: Mr Wong Shao Mun
 Vetter: Mdm Chung Bee Chee

<i>For Examiner's Use</i>	
Section B	50

This paper consists of **12** printed pages (including this cover page) and **0** blank pages.

Section B (50 marks)
Answer ALL questions.

- 17 The pie chart shows the categories of online videos watched by a group of people.

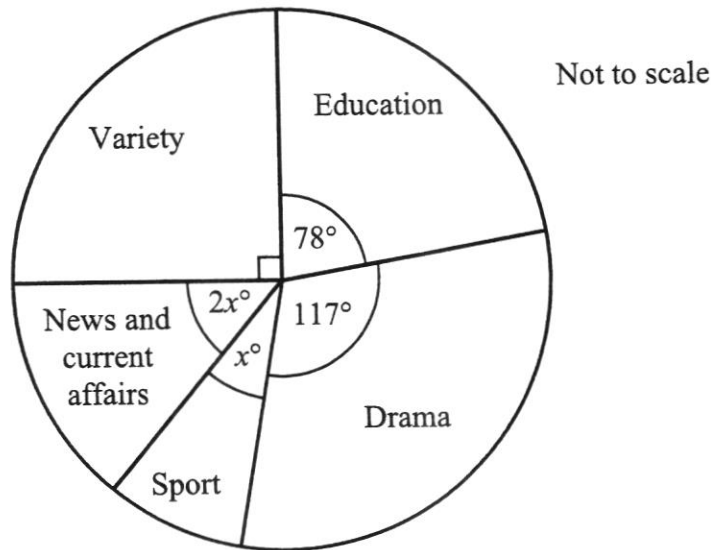

- (a) Calculate the value of x .
AO2 $90^\circ + 2x^\circ + x^\circ + 117^\circ + 78^\circ = 360^\circ$ (\angle s at a pt.) **M1**
 $3x^\circ + 285^\circ = 360^\circ$
 $3x^\circ = 360^\circ - 285^\circ$
 $3x^\circ = 75^\circ$
 $x^\circ = \frac{75^\circ}{3}$
 $x^\circ = 25^\circ$
 $x = 25$ Answer $x = \dots\dots\dots 25$ **A1** [2]

- (b) Calculate the percentage of people that watched drama.
AO1 Percentage of people who watched drama
 $= \frac{117^\circ}{360^\circ} \times 100\%$
 $= 32.5\%$ Answer $\dots\dots\dots 32.5$ **B1** % [1]

- (c) If 195 more people watched drama than education, find the total number of people in the group.
AO2

$$117^\circ - 78^\circ \rightarrow 195 \quad \mathbf{M1}$$

$$39^\circ \rightarrow 195$$

$$1^\circ \rightarrow \frac{195}{39}$$

$$360^\circ \rightarrow 360 \times \frac{195}{39} = 1800$$

Answer $\dots\dots\dots 1800$ **A1** people [2]

18

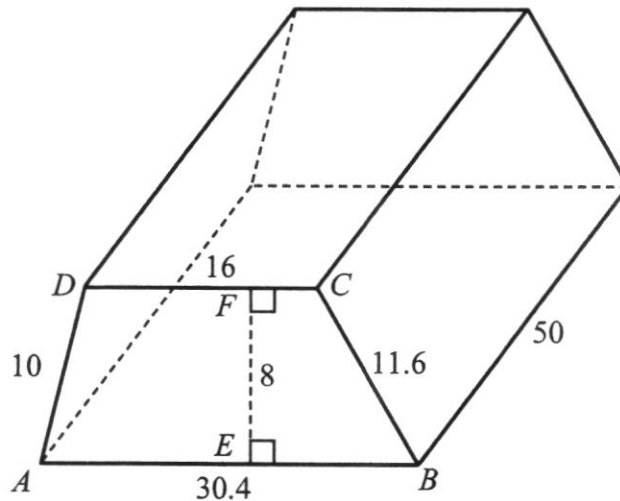

The diagram shows a prism whose cross-section is a trapezium, $ABCD$. $AB = 30.4$ cm, $BC = 11.6$ cm, $CD = 16$ cm, $AD = 10$ cm and $EF = 8$ cm. The length of the prism is 50 cm.

Calculate the

- (a) volume of the prism,
AO1

Method 1:

$$\begin{aligned} &\text{Volume of the prism} \\ &= \frac{1}{2}(16 + 30.4)(8) \times 50 \quad \text{M1: Seen } \frac{1}{2}(16 + 30.4)(8). \\ &= 185.6 \times 50 \\ &= 9280 \text{ cm}^3 \end{aligned}$$

Method 2:

$$\begin{aligned} &\text{Volume of } ABCD \\ &= 30.4 \times 8 - \frac{1}{2}(30.4 - 16)(8) \quad \text{M1} \\ &= 185.6 \text{ cm}^2 \end{aligned}$$

$$\begin{aligned} &\text{Volume of the prism} \\ &= 185.6 \times 50 \\ &= 9280 \text{ cm}^3 \end{aligned}$$

Answer 9280 A1 cm³ [2]

- (b) surface area of the prism.
AO1

$$\begin{aligned} &\text{Surface area of the prism} \\ &= 2 \times \frac{1}{2}(16 + 30.4)(8) \text{ [M1]} + (30.4 + 11.6 + 16 + 10)(50) \text{ [M1]} \\ &= 2 \times 185.6 + 68(50) \\ &= 371.2 + 3400 \\ &= 3771.2 \text{ cm}^2 \end{aligned}$$

Answer 3771.2 A1 cm² [3]

- 19 (a) A shirt costs \$18 after a 20% discount. Find its original price.
AO2

$$\begin{aligned}
 100\% - 20\% &\rightarrow \$18 \quad \text{M1} \\
 80\% &\rightarrow \$18 \\
 1\% &\rightarrow \frac{\$18}{80} \\
 100\% &\rightarrow 100 \times \frac{\$18}{80} = \$22.50 \\
 \therefore \text{Original price of shirt is } &\$22.50.
 \end{aligned}$$

Answer \$..... 22.50 A1 [2]

- (b) Chris deposits \$6000 in a savings account at a simple interest rate of 1.2% per annum.

- (i) Calculate the total interest earned in 3 years.
AO2

Method 1:

$$\begin{aligned}
 \text{Interest earned in 1 year} &= \$6000 \times 1.2\% \quad \text{M1} \\
 &= \$6000 \times \frac{1.2}{100} \\
 &= \$72
 \end{aligned}$$

$$\begin{aligned}
 \text{Interest earned in 3 years} &= \$72 \times 3 \\
 &= \$216
 \end{aligned}$$

Method 2:

$$\begin{aligned}
 \text{Interest earned in 3 years} &= \$6000 \times 1.2\% \times 3 \quad \text{M1} \\
 &= \$6000 \times \frac{1.2}{100} \times 3 \\
 &= \$216
 \end{aligned}$$

Answer \$..... 216 A1 [2]

- (ii) If he wants to earn a total interest of \$360, how long should the \$6000 be deposited?
AO2

$$\begin{aligned}
 &\text{Duration of deposit} \\
 &= \frac{\$360}{\$72/\text{year}} \quad \text{M1} \\
 &= 5 \text{ years}
 \end{aligned}$$

Answer 5 A1 years [2]

- 20 The first three terms in a sequence of numbers, T_1, T_2, T_3, \dots are given below.

$$T_1 = 3 + 4(1) = 7$$

$$T_2 = 3 + 4(2) = 11$$

$$T_3 = 3 + 4(3) = 15$$

- (a) (i) Find T_7 .

AO1

$$T_7 = 3 + 4(7) = 31$$

Answer $T_7 = \dots\dots\dots 31$ B1 [1]

(ii)
AO2

- Find an expression, in terms of n , for T_n .

Answer $T_n = \dots\dots\dots 3 + 4n$ B1 [1]

(iii)
AO3

- Explain why 165 is not a term of this sequence.

Method 1:

$$\begin{aligned} 165 &= 3 + 4n \\ 165 - 3 &= 4n \\ 162 &= 4n \\ 4n &= 162 \\ \frac{4n}{4} &= \frac{162}{4} \\ n &= 40.5 \end{aligned}$$

n represents the position number. Since $n = 40.5$ is not a positive integer, therefore 165 is not a term of this sequence. B1

Answer

Method 2:

$$\begin{aligned} 165 &= 3 + 4n \\ 165 - 3 &= 4n \\ 162 &= 4n \\ 4n &= 162 \end{aligned}$$

n represents the position number. Since 162 is not a multiple of 4 (162 is not divisible by 4), therefore 165 is not a term of this sequence. B1

Method 3:

$$\begin{aligned} T_{40} &= 3 + 4(40) = 163 \\ T_{41} &= 3 + 4(41) = 167 \end{aligned}$$

T_{40} is 163 and T_{41} is 167, therefore 165 is not a term of this sequence. B1

[1]

- (b) AO1 Solve $\frac{2x-1}{3x+2} = \frac{4}{13}$.

$$\frac{2x-1}{3x+2} = \frac{4}{13}$$

$$13(2x-1) = 4(3x+2) \quad \text{M1: Cross-multiply.}$$

$$26x - 13 = 12x + 8$$

$$26x - 12x = 8 + 13 \quad \text{M1: Terms correctly collected on each side of equation.}$$

$$14x = 21$$

$$\frac{14x}{14} = \frac{21}{14}$$

$$x = 1.5$$

1.5 A1

Accept $1\frac{1}{2}$.

Answer $x = \dots\dots\dots$ [3]

[Turn over

- 21 The bar graph shows the monthly number of customers who visited a shop from June to September.

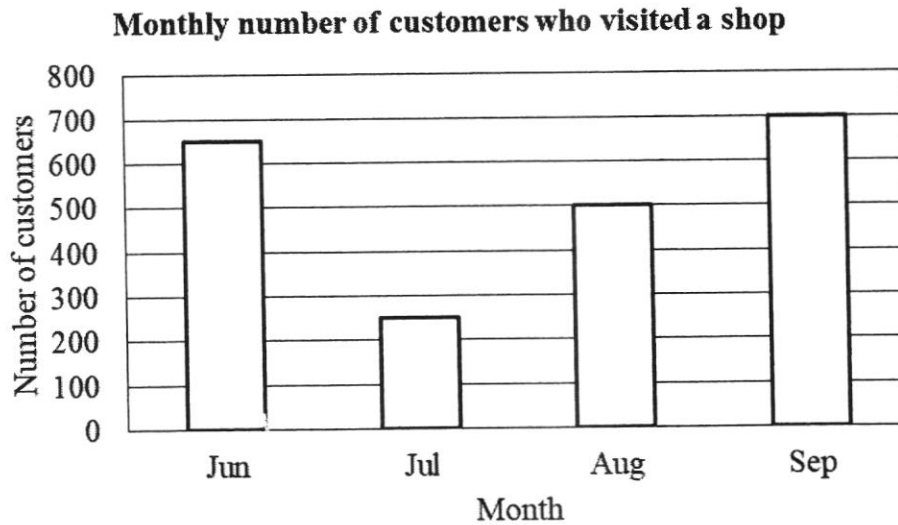

- (a) Calculate the monthly average of customers who visited the shop.
AO2

$$\begin{aligned} \text{Monthly average} &= \frac{650 + 250 + 500 + 700}{4} \quad \text{M1} \\ &= 525 \end{aligned}$$

Answer 525 A1 [2]

- (b) Calculate the percentage increase in the number of customers from August to September.
AO1

$$\begin{aligned} \text{Percentage increase} &= \frac{700 - 500}{500} \times 100\% \quad \text{M1} \\ &= 40\% \end{aligned}$$

Answer 40 A1 % [2]

- (c) Another bar graph shows the monthly sales of computers from October to November.
AO3

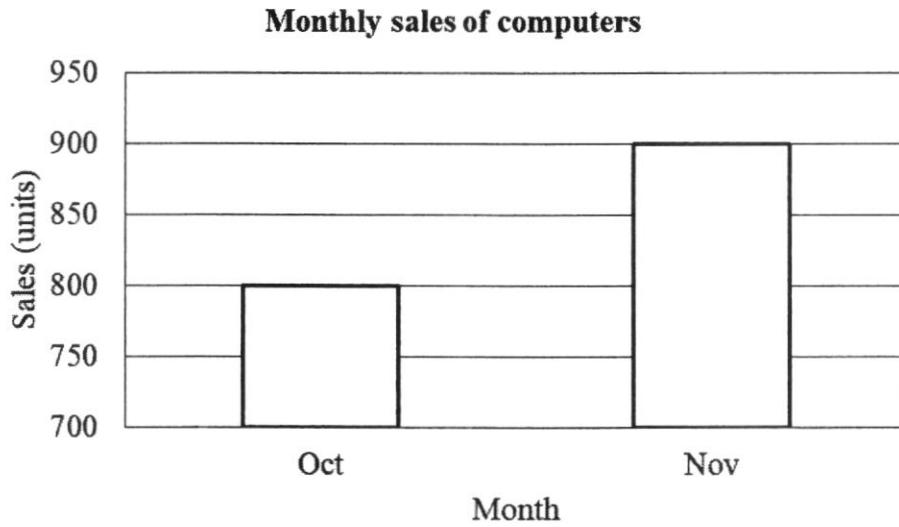

‘The number of computers sold in November is twice the number of computers sold in October.’

Explain why this statement is wrong.

800 computers and 900 computers were sold in October and November

.....
respectively [B1] and 900 computers is not the twice of 800. [B1]

.....
..... [2]

22 (a) Convert 72 km/h to m/s.

AO1

$$\begin{aligned}
 & 72 \text{ km/h} \\
 = & \frac{72 \times 1000 \text{ m}}{60 \times 60 \text{ s}} \quad \text{M1: Correct conversion to m and s.} \\
 = & \frac{72\,000 \text{ m}}{3600 \text{ s}} \\
 = & 20 \text{ m/s}
 \end{aligned}$$

Answer 20 A1 m/s [2]

(b) Daphne runs 6 km in 0.5 hour and rests for 0.25 hour.

AO1

Calculate the average speed for the whole journey.

$$\begin{aligned}
 & \text{Average speed for whole journey} = \frac{6 \text{ km}}{0.75 \text{ h}} \\
 = & \frac{\text{Total distance travelled}}{\text{Total time taken}} = 8 \text{ km/h} \\
 = & \frac{6 \text{ km}}{0.5 \text{ h} + 0.25 \text{ h}} \quad \text{M1}
 \end{aligned}$$

Accept $\frac{6 \text{ km}}{30 \text{ min} + 15 \text{ min}}$.

Answer 8 A1 km/h [2]

(c) Three buses leave a bus interchange at regular intervals. Bus A leaves every 5 minutes, Bus B leaves every 8 minutes and Bus C leaves every 34 minutes. All three buses leave the interchange together at 6 am. When will the three buses next leave together again?

AO2

Method 1:

$$\begin{aligned}
 & 5 = 5 \times 1 \\
 & 8 = 2^3 \\
 & 34 = 2 \times 17 \\
 \hline
 \text{LCM} &= 2^3 \times 5 \times 17 \quad \text{M1} \\
 \text{LCM} &= 680 \text{ min}
 \end{aligned}$$

Method 2:

2	5	8	34
2	5	4	17
2	5	2	17
5	5	1	17
17	1	1	17
	1	1	1

$$\begin{aligned}
 \text{LCM} &= 2^3 \times 5 \times 17 \quad \text{M1} \\
 \text{LCM} &= 680 \text{ min}
 \end{aligned}$$

Method 1:

$$680 \text{ min} = 11 \text{ h } 20 \text{ min} \quad \text{M1}$$

$$\begin{aligned}
 & \text{Time buses next leave together} \\
 &= 6 \text{ am} + 11 \text{ h } 20 \text{ min} \\
 &= 5.20 \text{ pm}
 \end{aligned}$$

Method 2:

$$680 \text{ min} = 11 \text{ h } 20 \text{ min} \quad \text{M1}$$

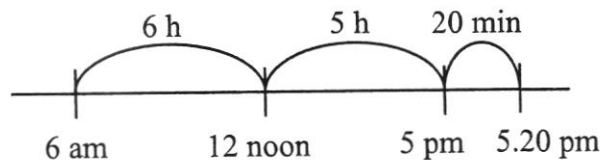

Answer 5.20 pm A1 [3]

23 (a)

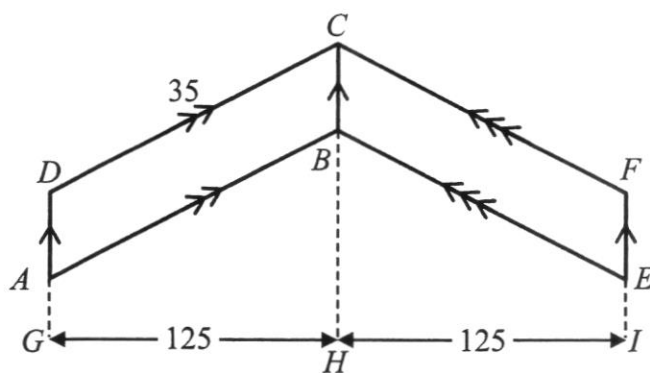

$ABEFCD$ is made up of two identical parallelograms, $ABCD$ and $BEFC$.
 $CD = 35$ cm and $GH = HI = 125$ cm.
 The perimeter of one parallelogram is 110 cm.

Calculate

(i) AD ,

AO2

$$AD + 35 + BC + 35 = 110 \quad \text{M1}$$

$$AD + 35 + AD + 35 = 110$$

$$2AD = 110 - 35 - 35$$

$$2AD = 40$$

$$\frac{2AD}{2} = \frac{40}{2}$$

$$AD = 20 \text{ cm}$$

Answer 20 A1 cm [2]

(ii) area of $ABEFCD$.

AO2

Method 1:

$$\text{Area of } ABEFCD = 20 \times (125 + 125) \quad \text{M1}$$

$$= 5000 \text{ cm}^2$$

Method 2:

$$\text{Area of } ABEFCD = 2 \times 20 \times 125 \quad \text{M1}$$

$$= 5000 \text{ cm}^2$$

Answer 5000 A1 cm² [2]

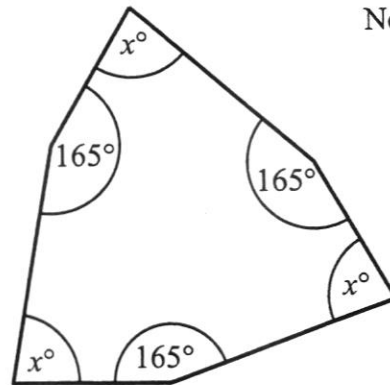
(b)
AO2

Not to scale

The diagram shows a hexagon.

Method 1: Find the value of x .

$$3 \times x^\circ + 3 \times 165^\circ \text{ [M1 for LHS]} = (6 - 2) \times 180^\circ \text{ [M1 for RHS]}$$

$$3x^\circ + 495^\circ = 4 \times 180^\circ$$

$$3x = 720 - 495$$

$$3x = 225$$

$$\frac{3x}{3} = \frac{225}{3}$$

$$x = 75$$

Method 2:

$$\text{Each exterior angle next to } x^\circ = \frac{360^\circ - 3 \times 165^\circ}{3} \text{ M1}$$

$$= \frac{315^\circ}{3}$$

$$= 105^\circ$$

$$x^\circ = 180^\circ - 105^\circ \text{ (adj. } \angle\text{s on a str. line) M1}$$

$$x^\circ = 75^\circ$$

$$x = 75$$

$$\text{Answer } x = \dots\dots\dots 75 \text{ A1} \quad [3]$$

(c)
AO3

The angles of a quadrilateral are measured and recorded as below.

Measurement	W	X	Y	Z
Interior angle	91°	48°	114°	108°
Exterior angle	89°	132°	67°	72°

Identify which pair of measurement is wrong and explain why.

Measurement Y is wrong because**interior angle + exterior angle = $114^\circ + 67^\circ \neq 180^\circ$. B1**

..... [1]

24 Below is some information about electricity use.

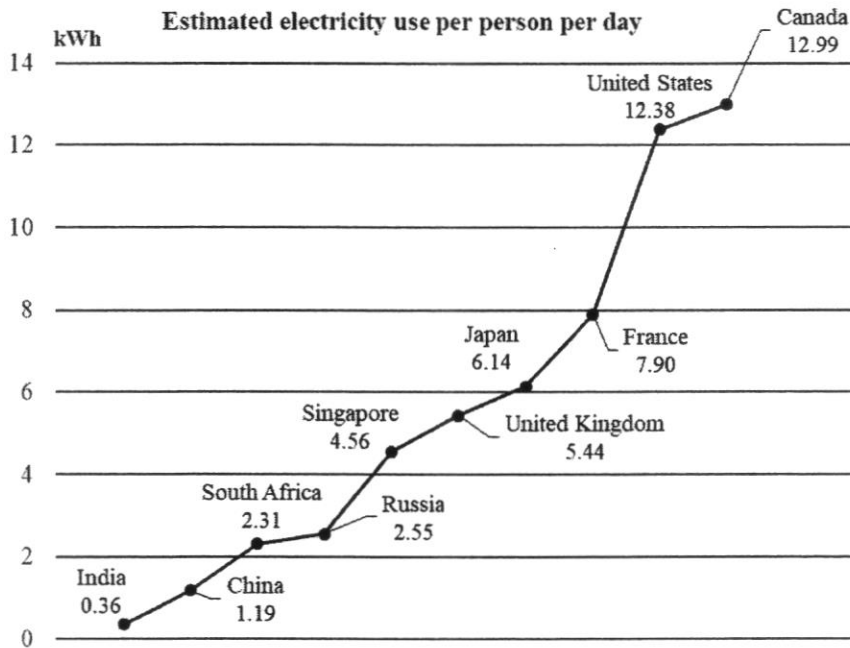

Percentage breakdown of electricity use for appliances in a typical Singapore household

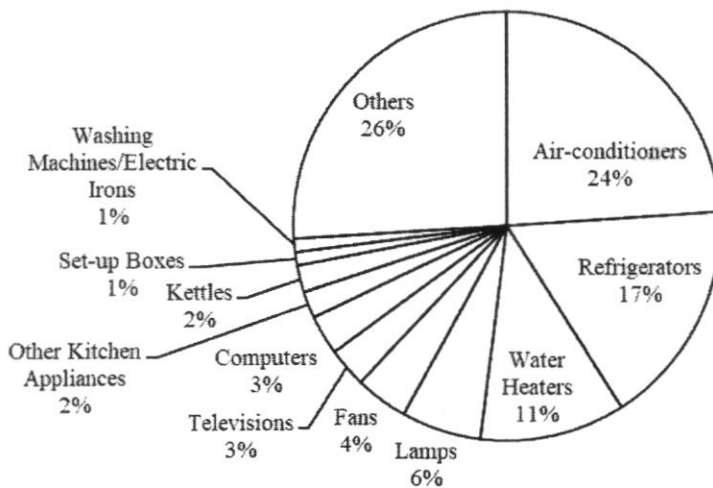

(a) In Singapore, what is the estimated electricity use per person per day for water heaters?
AO2

$$\begin{aligned}
 &\text{Estimated usage per person per year for water heaters} \\
 &= 11\% \times 4.56 \quad \mathbf{M1} \\
 &= \frac{11}{100} \times 4.56 \\
 &= 0.5016 \text{ kWh}
 \end{aligned}$$

0.5016 A1

Reject $\frac{627}{1250}$.

Answer kWh [2]

[Turn over

- (b) (i) Find the total electricity use per day for a typical Singapore household of 4 people.

AO1

$$\begin{aligned} & \text{Total electricity use per day} \\ &= 4 \times 4.56 \text{ M1} \\ &= 18.24 \text{ kWh} \end{aligned}$$

Answer 18.24 A1 kWh [2]

- (ii) There are 4 people in the Tan family.
AO3 The percentage of electricity they use for air-conditioners is the same as the percentage for a typical Singapore household.
The Tan family uses an average of 19 kWh of electricity per day.

Mr Tan claims that if each person in the family reduces their air-conditioning use time from 8 hours to 6 hours, the family can get their total electricity use to below that of a typical Singapore household of 4 people.

Is Mr Tan correct?
Explain your answer.

Answer

$$\begin{aligned} & \text{Usage for Tan family per day for air-conditioners} \\ &= 24\% \times 19 \text{ M1} \\ &= \frac{24}{100} \times 19 \\ &= 4.56 \text{ kWh} \end{aligned}$$

$$\begin{aligned} & \text{Total electricity use for Tan family per day at reduced air-conditioner time} \\ &= 19 - \frac{2}{8} \times 4.56 \text{ M1} \\ &= 19 - 1.14 \\ &= 17.86 \text{ kWh} \end{aligned}$$

Since 17.86 kWh is less than a typical Singapore household's use of 18.24 kWh, Mr Tan is correct. A1

[3]

END OF SECTION B