

*Visit*

**FREETESTPAPER.com**

*for more papers*



Website: [freetestpaper.com](http://www.freetestpaper.com)



[Facebook.com/freetestpaper](https://www.facebook.com/freetestpaper)



[Twitter.com/freetestpaper](https://www.twitter.com/freetestpaper)

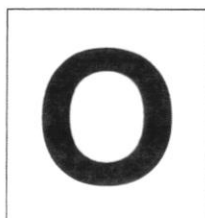

**NORTHBROOKS SECONDARY SCHOOL**  
**End-of-Year Examination 2022**  
**Secondary 1 Express**



CANDIDATE NAME	
-------------------	--

CLASS	
-------	--

REGISTER NUMBER		
--------------------	--	--

---

**MATHEMATICS**

**4052/01**

Paper 1

**3 October 2022**

Candidates answer on the Question Paper.

---

**1 hour 15 minutes**

**READ THESE INSTRUCTIONS FIRST**

Write your name, register number and class on all the work you hand in.  
 Write in dark blue or black pen.  
 You may use an HB pencil for any diagrams or graphs.  
 Do not use staples, paper clips, glue or correction fluid.

Answer **all** the questions.

The number of marks is given in brackets [ ] at the end of each question or part question.

If working is needed for any question it must be shown with the answer.

Omission of essential working will result in loss of marks.

The total of the marks for this paper is 50.

The use of an approved scientific calculator is expected, where appropriate.

If the degree of accuracy is not specified in the question and if the answer is not exact, give the answer to three significant figures. Give answers in degrees to one decimal place.

For  $\pi$ , use either your calculator value or 3.142.

FOR EXAMINER'S USE											
Q1	Q2	Q3	Q4	Q5	Q6	Q7	Q8	Q9	Q10	Q11	50

**DO NOT TURN THE PAGE UNTIL YOU ARE TOLD TO DO SO.**

This document consists of 12 printed pages.

Setter: Mrs Tan QianYu

***Mathematical Formulae***

*Compound interest*

$$\text{Total amount} = P \left( 1 + \frac{r}{100} \right)^n$$

*Mensuration*

$$\text{Curved surface area of a cone} = \pi r l$$

$$\text{Surface area of a sphere} = 4\pi r^2$$

$$\text{Volume of a cone} = \frac{1}{3}\pi r^2 h$$

$$\text{Volume of a sphere} = \frac{4}{3}\pi r^3$$

$$\text{Area of triangle } ABC = \frac{1}{2}ab \sin C$$

Arc length =  $r\theta$ , where  $\theta$  is in radians

$$\text{Sector area} = \frac{1}{2}r^2\theta, \text{ where } \theta \text{ is in radians}$$

*Trigonometry*

$$\frac{a}{\sin A} = \frac{b}{\sin B} = \frac{c}{\sin C}$$

$$a^2 = b^2 + c^2 - 2bc \cos A$$

*Statistics*

$$\text{Mean} = \frac{\sum fx}{\sum f}$$

$$\text{Standard deviation} = \sqrt{\frac{\sum fx^2}{\sum f} - \left(\frac{\sum fx}{\sum f}\right)^2}$$

Answer **all** the questions.

**1** The number of people in a concert is 55 000, correct to the nearest thousand.

**(a)** Write down the maximum number of people that could be in the concert.

*Answer*..... [1]

**(b)** Write down the minimum number of people that could be in the concert.

Answer..... [1]

2 Consider the following numbers.

$$\sqrt{5} \quad , \quad 1 \quad , \quad \sqrt[3]{125} \quad , \quad -0.\dot{5} \quad , \quad \frac{\pi}{2} \quad , \quad \frac{22}{7} \quad , \quad \frac{3}{4}$$

(a) Write down the prime number(s).

Answer ..... [1]

(b) Write down the irrational number(s).

Answer ..... [1]

3 Choose a symbol from the list below to make a correct statement.

<   =   >

(a)  $-5$  \_\_\_\_\_  $4$

Answer ..... [1]

(b)  $\frac{2}{3}$  \_\_\_\_\_  $66\%$

Answer ..... [1]

(c)  $0.\dot{2}\dot{7}$  \_\_\_\_\_  $\frac{3}{11}$

*Answer* ..... [1]

- 4 (a) Express 588 as a product of its prime factors.

*Answer*..... [1]

- (b) Given that  $504 = 2^3 \times 3^2 \times 7$ , find the largest integer which is a factor of both 504 and 588.

*Answer* ..... [1]

(c) Find the smallest positive integer  $m$  such that  $\sqrt[3]{504m}$  is a positive integer.

*Answer*  $m = \dots\dots\dots$  [1]

(d) Find the smallest positive integer  $n$  such that  $504n$  is a multiple of 588.

*Answer*  $n = \dots\dots\dots$  [1]

---

5 (a) Expand and simplify  $2x - [5 - 3(7x - 1)]$ .

*Answer*  $\dots\dots\dots$  [3]

(b) Factorise  $27a^2b - 9a$ .

Answer ..... [2]

- (c) Given that  $3x + y = 2x + 5y$ , find the exact value of  $\frac{x}{2y}$ .

Answer ..... [3]

- 6 Adrian bought 27 cups of drinks.  
Out of these, there were  $x$  cups of milk tea that cost \$2.50 per cup and the rest were coffee which cost \$3.00 per cup.  
He spent a total of \$75.

- (a) Write in terms of  $x$ ,  
(i) the total cost of the milk tea,

Answer \$ ..... [1]

- (ii) the total cost of the coffee.

Answer \$ ..... [1]

- (b) By forming an equation in terms of  $x$ , find the number of cups of milk tea that Adrian bought.

*Answer* ..... [3]

- 7 A shopkeeper's profit in 2021 was \$17 600.  
This was a decrease of 20% from the profit earned in 2020.  
The profit earned in 2020 was an increase of 10% from the profit earned in 2019.

Calculate

- (a) the profit earned in 2020,

*Answer* \$..... [2]

- (b) the profit earned in 2019,

*Answer* \$..... [2]

- (c) the percentage decrease in the profit earned in 2021 as compared to 2019.

*Answer* .....% [2]

- 
- 8** Alvin cycled at a speed of 16 km/h for 1 hour 30 minutes from Town *X* to Town *Y*.  
He then stopped and rested for 45 minutes at Town *Y*.  
After that, he cycled from Town *Y* to Town *X* at 12 km/h.

- (a) Find the distance, in kilometres, between Town *X* and Town *Y*.

*Answer* .....km [1]

- (b) Find the time taken for Alvin to cycle from Town *Y* to Town *X*.

*Answer* .....hours [1]

(c) Find the average speed of his entire journey.

*Answer* .....km/h [3]

---

- 9 The graph shows the line  $2y = x + 4$ . Points  $A$  and  $B$  lie on the line. Point  $A$  lies on the  $x$ -axis and point  $B$  lies on the  $y$ -axis.

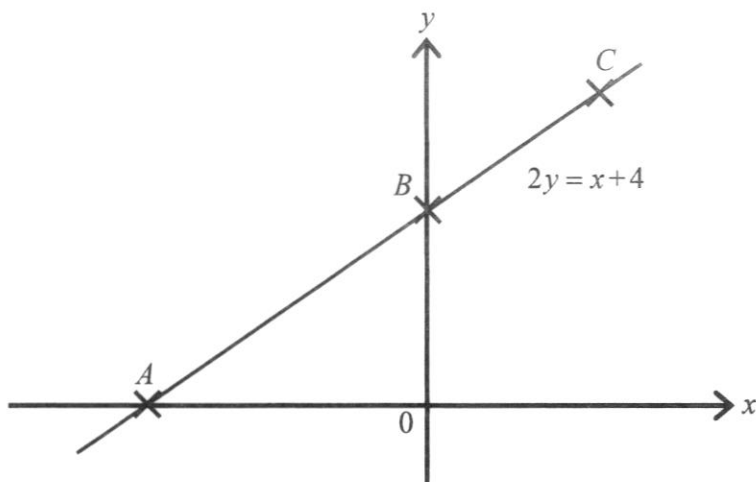

- (a) Write down the coordinates of points  $A$  and  $B$ .

*Answer A* (....., .....) [1]

*B* (....., .....) [1]

- (b) Find the gradient of the line  $2y = x + 4$ .

*Answer*..... [1]

- (c)  $C$  is the point  $(2, k)$ . Point  $C$  lies on the line  $2y = x + 4$ . Find the value of  $k$ .

*Answer*  $k =$ ..... [2]

- 10 The diagram below shows a regular polygon with 6 sides. One exterior angle is shown below.

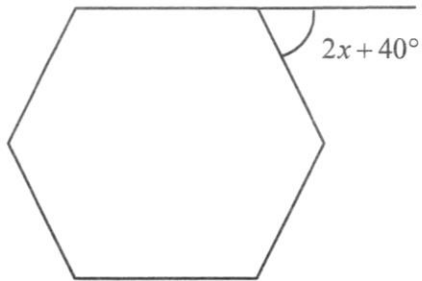

- (a) Find the size of each exterior angle.

*Answer*..... [2]

- (b) Find the value of  $x$ .

*Answer*  $x =$  ..... [2]

- 11 The figure shows a field made up of a semicircle  $ABC$  and a trapezium  $ACDE$ .  $CA = 40$  m,  $ED = 30$  m and the perpendicular height of the trapezium is 25 m.  $AC$  is parallel to  $DE$ .

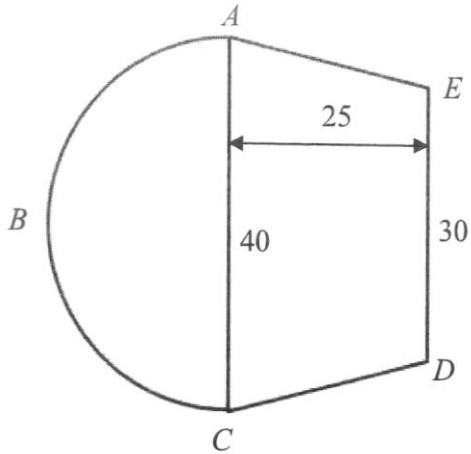

- (a) Calculate the area of the field.

Answer.....m<sup>2</sup> [3]

- (b) If it costs \$2.10 per 1 m<sup>2</sup> of grass, find the cost of planting grass on the whole field.  
Give your answer correct to the nearest dollar.

Answer \$..... [3]

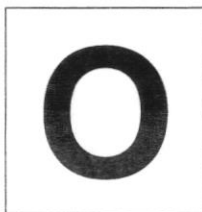

**NORTHBROOKS SECONDARY SCHOOL**  
**End-of-Year Examination 2022**  
**Secondary 1 Express**



CANDIDATE NAME			
CLASS		REGISTER NUMBER	

**MATHEMATICS****4052/02**

Paper 2

**30 September 2022****1 hour 15 minutes**

Candidates answer on the Question Paper.

**READ THESE INSTRUCTIONS FIRST**

Write your name, register number and class on all the work you hand in.

Write in dark blue or black pen.

You may use an HB pencil for any diagrams or graphs.

Do not use staples, paper clips, glue or correction fluid.

Answer **all** the questions.

The number of marks is given in brackets [ ] at the end of each question or part question.

If working is needed for any question it must be shown with the answer.

Omission of essential working will result in loss of marks.

The total of the marks for this paper is 50.

The use of an approved scientific calculator is expected, where appropriate.

If the degree of accuracy is not specified in the question and if the answer is not exact, give the answer to three significant figures. Give answers in degrees to one decimal place.

For  $\pi$ , use either your calculator value or 3.142.

FOR EXAMINER'S USE												
Q1	Q2	Q3	Q4	Q5	Q6	Q7	Q8	Q9	Q10	Q11	Q12	
												<b>50</b>

**DO NOT TURN THE PAGE UNTIL YOU ARE TOLD TO DO SO.**

This document consists of 12 printed pages.

Setter: Mr Adrian Tan

Answer **all** the questions.

1 (a) Calculate  $\sqrt{\frac{-2.56 + 7.01 \times 3.45 - (-3)^2}{200.1^2}}$ .

Write down the first 6 digits shown on your calculator.

*Answer* ..... [1]

(b) Round off your answer to part (a) correct to two significant figures.

*Answer* ..... [1]

2 (a) By rounding each number correct to 1 significant figure, estimate

$$\frac{5.04 \times 19.86}{4.97}$$

*Answer* ..... [1]

(b) **Without using a calculator**, estimate  $\frac{\sqrt{50.4} \times \sqrt{101.5}}{\sqrt{4.1}}$ .

*Answer* ..... [2]

- 3 A van travelled 322 000 m on 35 litres of diesel. The total price of the diesel used was \$43.75.

Calculate

- (a) the price of diesel per litre,

*Answer* \$.....per litre [2]

- (b) the rate of diesel consumption in km per litre.

*Answer* .....km per litre [2]

- 4 If  $k = \sqrt{\frac{2m}{q}} - n$ , find the value of  $k$  when  $n = -3$ ,  $q = -1$  and  $m = -8$ .

*Answer*  $k =$  ..... [2]

5 Express the following expressions as a single fraction.

(a)  $\frac{3x+1}{5} - \frac{x-2}{3}$

*Answer* ..... [2]

(b)  $1 + \frac{2x-4}{3}$

*Answer* ..... [2]

6 Solve the following equations.

(a)  $7k + 11 = 12 - 3k$

*Answer k =* ..... [2]

(b)  $7 - m = \frac{-3m + 4}{5}$

*Answer m =* ..... [3]

7

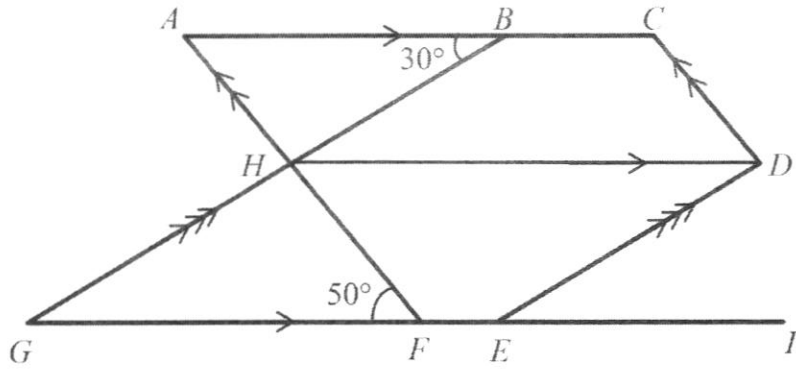

In the figure above,  $AC$  is parallel to  $GI$  and  $HD$ .  
 $AF$  is parallel to  $CD$  and  $BG$  is parallel to  $DE$ .

Stating your reasons clearly, find

(a) angle  $BHF$ ,

Answer Angle  $BHF$  = ..... [2]

(b) angle  $CDE$ .

Answer Angle  $CDE$  = ..... [3]

- 8 The ratio of Lionel's expenditure on food to his expenditure on clothes is 5 : 7.  
The ratio of his expenditure on food to his expenditure on transport is 3 : 2.  
He spends \$132 more on clothes than on transport.

Find Lionel's total expenditure.

*Answer \$..... [3]*

9 The diagram below shows a sequence formed using diamonds.

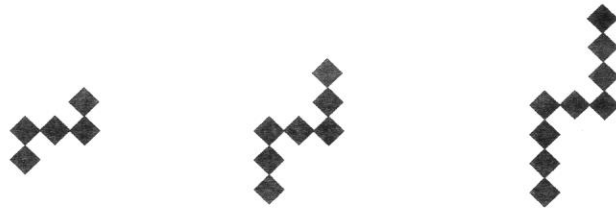

Figure 1

Figure 2

Figure 3

(a) Complete the table below.

Figure number	1	2	3	4	5
Number of diamonds	5	7	9		

[2]

(b) Write down an expression, in terms of  $n$ , for the number of diamonds in Figure  $n$ .

*Answer* ..... [1]

(c) Find the number of diamonds in Figure 80.

*Answer* ..... [1]

(d) Is it possible for a figure to have 100 diamonds? Explain your answer.

*Answer* .....

.....

..... [2]

10  $x$  and  $y$  are related by the equation  $y = 2 - 3x$ .

(a) Complete the table below.

$x$	-1	0	1
$y$		2	

[2]

(b) Draw the graph of  $y$  against  $x$  in the grid below.

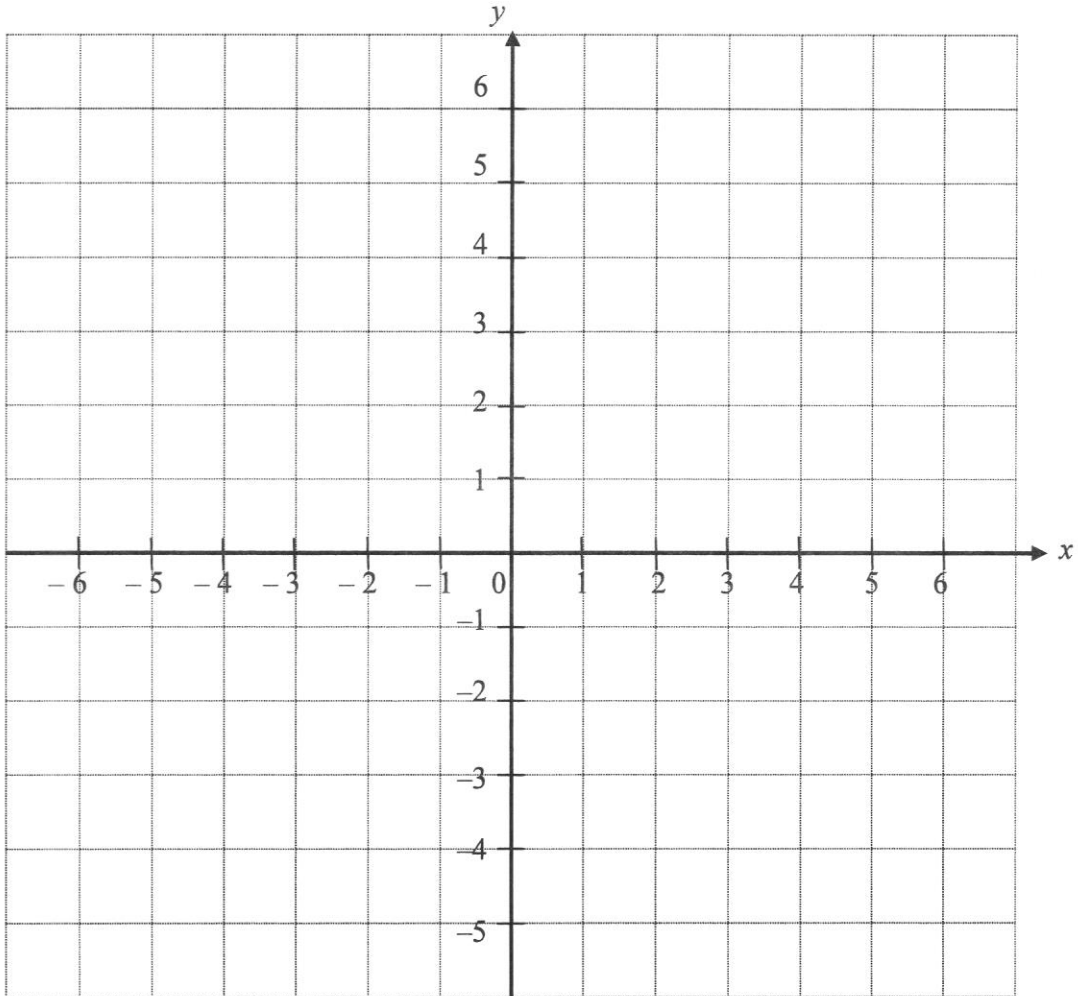

[3]

(c) State the gradient and  $y$ -intercept of the graph  $y = 2 - 3x$ .

Answer gradient = .....

$y$ -intercept = ..... [2]

(d) From the graph, write down the value of  $x$  when  $y = -4$ .

Answer  $x =$  ..... [1]

11  $PQR$  is a triangle. The side  $PQ$  has already been drawn in the space below.

(a) Construct triangle  $PQR$  where  $QR = 10.5$  cm and  $PR = 8$  cm.

[2]

*Answer*



(b) Measure angle  $QPR$ .

*Answer* Angle  $QPR = \dots\dots\dots$  [1]

- 12 A cylindrical container of height 25 cm and radius 8 cm contains water to a depth of 12 cm.

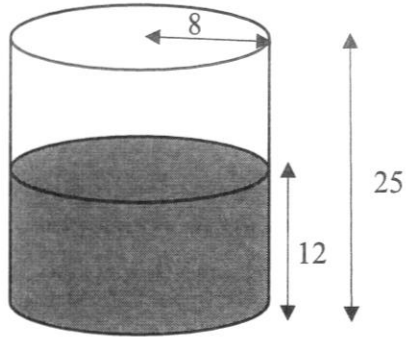

- (a) Calculate the volume of the water.

*Answer* .....  $\text{cm}^3$  [2]

- (b) Solid metal cubes of length 3 cm are fully submerged in the water.

Find the maximum number of metal cubes that can be submerged in the water so that the water will not flow out of the cylindrical container.

*Answer* ..... [3]



1a	55 499	B1
1b	54 500	B1
2a	$\sqrt[3]{125}$	B1
2b	$\frac{\pi}{2}, \sqrt{5}$	B1
3a	<	B1
3b	>	B1
3c	=	B1
4a	$588 = 2^3 \times 3 \times 7^2$	B1
4b	84	B1
4c	147	B1
4d	7	B1
5a	$2x - [5 - 3(7x - 1)]$ $= 2x - [5 - 21x + 3]$ $= 2x - [8 - 21x]$ $= 2x - 8 + 21x$ $= 23x - 8$	M1  M1 A1
5b	$27a^2b - 9a$ $= 9a(3ab - 1)$	B1 for $9a$ B1 for $(3ab - 1)$
5c	$3x + y = 2x + 5y$ $3x - 2x = 5y - y$ $x = 4y$ $\frac{x}{y} = \frac{4}{1}$ $\frac{x}{2y} = \frac{1}{2} \left( \frac{x}{y} \right)$ $\frac{x}{2y} = \frac{1}{2} \left( \frac{4}{1} \right)$ $\frac{x}{2y} = 2$	M1 M1     A1
6ai	$2.5x$	B1
6aii	$3(27 - x)$ or $75 - 2.5x$	B1

6b	$3(27 - x) + 2.5x = 75$ $81 - 3x + 2.5x = 75$ $-0.5x = -6$ $x = 12$	M1 M1  A1
7a	$\text{Profit} = \frac{17600}{80} \times 100$ $= \$22\,000$	M1  A1
7b	$\text{Profit} = \frac{22000}{110} \times 100$ $= \$20\,000$	M1 ecf  A1
7c	$\% \text{ decrease} = \frac{20000 - 17600}{20000} \times 100\%$ $= 12\%$	M1 ecf  A1
8a	Distance = 24 km	B1
8b	Time = 2 hours	B1 ecf
8c	$\text{Average speed} = \frac{48}{1.5 + 0.75 + 2}$ $= 11.3 \text{ km/h (3 s.f.)}$	M2 ecf for total distance and time  A1
9a	A (-4, 0) B (0, 2)	B1 B1
9b	Gradient = $\frac{1}{2}$	B1
9c	$2y = x + 4$ $2(k) = (2) + 4$ $k = 3$	M1 A1
10a	$\frac{360}{6}$ $= 60^\circ$	M1  A1
10b	$2x + 40 = 60$ $2x = 60 - 40$ $x = \frac{20}{2}$ $x = 10$	M1   A1
11a	Area of field	M1 for area of semi circle

## 16

	$= \frac{1}{2} \times \pi \times (20)^2 + \frac{1}{2} \times (30 + 40) \times 25$ $= 1503.318$ $= 1500 \text{ m}^2 \text{ (3s.f.)}$	M1 for area of trapezium  A1
11b	$\text{Total cost} = 1503.318 \times 2.10$ $= \$3156.96$ $= \$3157 \text{ (nearest dollar)}$	M1 for area M1 for cost of grass  A1

**Mathematics 1 Express**  
**Paper 2 Marking Scheme**  
**EOY 2022**  
**Setter: Mr Adrian Tan**

1	(a) 0.01775  (b) 0.018	B1  B1
2(a)	$\frac{5 \times 20}{5}$ $= 20$	B1
2(b)	$\frac{\sqrt{50.4} \times \sqrt{101.5}}{\sqrt{4.1}} = \frac{7 \times 10}{2}$ $= 35$	M1  A1
3(a)	$\frac{\$43.75}{35 \text{ l}}$ $= \$1.25/\text{l}$	M1  A1
3(b)	$\frac{322 \text{ km}}{35 \text{ l}}$ $= 9.2 \text{ km/l}$	M1  A1
4	$k = \sqrt{\frac{2m}{q}} - n$ $= \sqrt{\frac{2(-8)}{-1}} - (-3)$ $= \sqrt{16} + 3$ $= 7$	M1  A1
5(a)	$\frac{3x+1}{5} - \frac{x-2}{3} = \frac{9x+3}{15} - \frac{5x-10}{15}$ $= \frac{9x+3-5x+10}{15}$ $= \frac{4x+13}{15}$	M1  A1
5(b)	$1 + \frac{2x-4}{3} = \frac{3}{3} + \frac{2x-4}{3}$ $= \frac{3+2x-4}{3}$ $= \frac{2x-1}{3}$	M1  A1
6(a)	$7k+11=12-3k$ $10k=1$ $k=\frac{1}{10}$	M1  A1

6(b)	$7 - m = \frac{-3m + 4}{5}$ $35 - 5m = -3m + 4$ $-2m = -31$ $m = \frac{31}{2}$ $m = 15.5$	M1 M1  A1												
7(a)	$\angle BGF = 30^\circ$ (alt. $\angle$ s) $\angle BHF = 30^\circ + 50^\circ$ (ext. $\angle$ of triangle) $= 80^\circ$	M1  A1												
7(b)	$\angle BAF = 50^\circ$ (alt. $\angle$ s, $AB \parallel GF$ ) $\angle CDH = 50^\circ$ (opp. $\angle$ s of parallelogram) $\angle DEI = 30^\circ$ (corr. $\angle$ s, $DE \parallel HG$ ) $\angle EDH = 30^\circ$ (alt. $\angle$ s, $DH \parallel IE$ ) $\angle CDE = 30^\circ + 50^\circ$ $= 80^\circ$	M1  M1  A1												
8	$F : C : T$ $5 : 7$ $3 : 2$ $15 : 21 : 10$  $132 \div 11 = 12$ $12 \times 46 = \$552$	M1  M1 A1												
9(a)	<table border="1" style="width: 100%; text-align: center;"> <thead> <tr> <th>Figure number</th> <th>1</th> <th>2</th> <th>3</th> <th>4</th> <th>5</th> </tr> </thead> <tbody> <tr> <td>Number of diamonds</td> <td>5</td> <td>7</td> <td>9</td> <td>11</td> <td>13</td> </tr> </tbody> </table>	Figure number	1	2	3	4	5	Number of diamonds	5	7	9	11	13	B1, B1
Figure number	1	2	3	4	5									
Number of diamonds	5	7	9	11	13									
9(b)	$2n + 3$	B1												
9(c)	$2(80) + 3 = 163$	B1												
9(d)	$2n + 3 = 100$ $2n = 97$ $n = 48.5$ Since $n$ is not a positive integer, it is impossible to have a figure with 100 diamonds.	M1  A1												
10(a)	<table border="1" style="width: 100%; text-align: center;"> <tbody> <tr> <td><math>x</math></td> <td>-1</td> <td>0</td> <td>1</td> </tr> <tr> <td><math>y</math></td> <td>5</td> <td>2</td> <td>-1</td> </tr> </tbody> </table>	$x$	-1	0	1	$y$	5	2	-1	B1 B1				
$x$	-1	0	1											
$y$	5	2	-1											

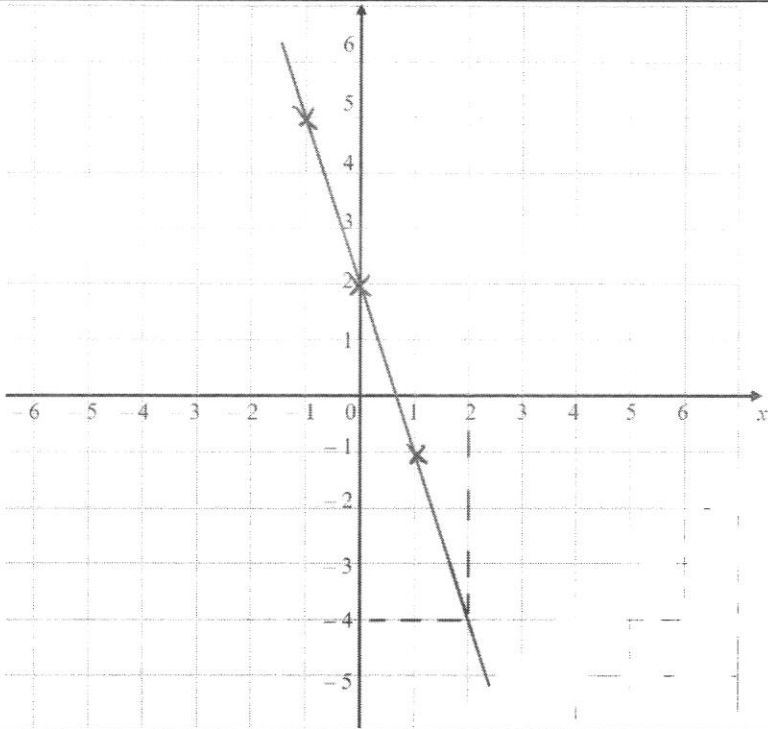
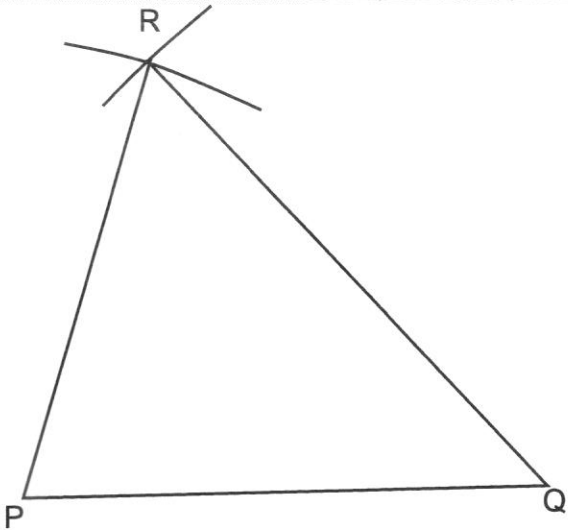
<p>10(b)</p>		<p>B2 (all 3 points plotted correctly)</p> <p>(Award 1 mark if 1 or 2 out of 3 points are plotted correctly)</p> <p>B1 (straight line drawn and must pass through all 3 correct points)</p>
<p>10(c)</p>	<p>Gradient = -3 y-intercept = 2</p>	<p>B1 B1</p>
<p>10(d)</p>	<p>2</p>	<p>B1 (dotted lines drawn in the grid as proof that student uses the graph to solve for x)</p>
<p>11(a)</p>		<p>B1 construction evidence shown with <math>QR = 10.5\text{cm}</math></p> <p>B1 construction evidence shown with <math>PR = 8\text{cm}</math></p>
<p>11(b)</p>	<p><math>73^\circ</math></p>	<p>B1</p>
<p>12(a)</p>	<p>Volume = <math>\pi(8)^2(12)</math>  <math>= 2412.74</math>  <math>\approx 2410 \text{ cm}^3</math></p>	<p>M1 A1</p>
<p>12(b)</p>	<p>Volume of empty space = <math>\pi(8)^2(13)</math>  <math>= 2613.8 \text{ cm}^3</math></p> <p>Volume of 1 cube = <math>3^3 = 27 \text{ cm}^3</math></p>	<p>M1 M1</p>

	$\frac{2613.8}{27} = 96.8$ Maximum number of cubes = 96	A1
--	---	----