

Visit

FREETESTPAPER.com

for more papers



Website: [freetestpaper.com](http://www.freetestpaper.com)



[Facebook.com/freetestpaper](https://www.facebook.com/freetestpaper)



[Twitter.com/freetestpaper](https://www.twitter.com/freetestpaper)

Register
Number

Class

Name:

DUNEARN SECONDARY SCHOOL DUNEARN SECONDARY SCHOOL DUNEARN SECONDARY SCHOOL DUNEARN SECONDARY SCHOOL DUNEARN SECONDARY SCHOOL DUNEARN SECONDARY SCHOOL
 DUNEARN SECONDARY SCHOOL DUNEARN SECONDARY SCHOOL DUNEARN SECONDARY SCHOOL DUNEARN SECONDARY SCHOOL DUNEARN SECONDARY SCHOOL DUNEARN SECONDARY SCHOOL
 DUNEARN SECONDARY SCHOOL DUNEARN SECONDARY SCHOOL DUNEARN SECONDARY SCHOOL DUNEARN SECONDARY SCHOOL DUNEARN SECONDARY SCHOOL DUNEARN SECONDARY SCHOOL
 DUNEARN SECONDARY SCHOOL DUNEARN SECONDARY SCHOOL DUNEARN SECONDARY SCHOOL DUNEARN SECONDARY SCHOOL DUNEARN SECONDARY SCHOOL DUNEARN SECONDARY SCHOOL
 DUNEARN SECONDARY SCHOOL DUNEARN SECONDARY SCHOOL DUNEARN SECONDARY SCHOOL DUNEARN SECONDARY SCHOOL DUNEARN SECONDARY SCHOOL DUNEARN SECONDARY SCHOOL



DUNEARN SECONDARY SCHOOL MID-YEAR EXAMINATION 2017

LOWER SECONDARY SCIENCE

Secondary One Express

3th May 2017 (Wednesday)

0800 – 1000

2 hours

INSTRUCTIONS TO CANDIDATES

Write in dark blue or black pen for your answers.
 You may use a pencil for diagrams or graphs.
 Do not use staples, paper clips, glue or correction fluid.

Answer **ALL** the questions in Section A.
 For each of the question, there are 4 possible answers, **A, B, C** and **D**.
 Choose the **one** you consider correct and shade the answers in the OTAS sheet provided.

Answer **ALL** questions in Section B and C by writing in the spaces provided.
 The number of marks is given in brackets [] at the end of the question or part question.

If needed, take $g = 10 \text{ N/kg}$.

Candidates are reminded that **all** quantitative answers should include appropriate units and rounded off to appropriate significant figures or decimal places.

Candidates are advised to show all their workings in a clear and orderly manner.

Section B Q1	Section B Q2	Section B Q3	Section B Q4	Section B Q5	Section B Q6	Section B Q7	Section B Q8		Section C Q9	Section C Q10	Section C Q11
Parent's Signature: _____ Setter: Miss Sandy Tan and Mr Chen Zhiyong								Section	Marks		
								A	/30		
								B	/40		
								C	/30		
								Penalties			
								Overall Marks	/100		

2

Section A [30 marks]

Answer **all** questions in this section in the OTAS provided.

- 1 How can the abuse and misuse of science and technology be **reduced**?
- A by adopting positive attitudes in science like responsibility and integrity
 - B by using skills and processes to inquire about the objects in the environment
 - C by using the scientific method
 - D by working together in a team
- 2 Which of the following is the correct order of the steps to be carried out for a scientific method of investigation?
- I analysing
 - II experimenting
 - III making a conclusion
 - IV making a hypothesis
 - V observing
- A I, III, II, IV, V
 - B III, IV, II, I, V
 - C V, II, I, III, IV
 - D V, IV, II, I, III
- 3 Joan carried out an experiment to test the hypothesis that plants grow slower when rock music is played to them. She used two young identical plants of the same height and placed one of them with rock music. Both plants were left **untouched** for one week. She then measured the increase in height of both plants at the end of the week.
- Which of the following is the variable to be measured (dependent variable) in this experiment?
- A increase in height of each plant at the end of the week
 - B length of time that the plants were left untouched
 - C presence of rock music
 - D type of plants used

3

- 4 The diagram below shows a safety hazard symbol. The symbol was displayed on a bottle.



Which of the following correctly describes the chemical found in the bottle?

- A explosive
 B flammable
 C harmful
 D oxidising
- 5 Which of the following differences between a luminous and a non-luminous flame is **incorrect**?

	Luminous	Non-luminous
A	easy to see from far	not easy to see from far
B	flame is orange	flame is blue
C	obtained when the air-hole is open	obtained when the air-hole is closed
D	produces a lot of soot	does not produce soot

- 6 Why is the handle of a cooking pan made of plastic?

- A Plastic has a high melting point.
 B Plastic has low electrical conductivity.
 C Plastic is a bad conductor of heat.
 D Plastic is resistant to corrosion.

- 7 A stack of 100 identical sheets of plain A4-sized papers has a thickness of 1.2 cm.



What is the thickness of each sheet of paper?

- A 0.12 mm
 B 1.2 mm
 C 12 mm
 D 120 mm

4

- 8 The diagram below shows a teaspoon and a tablespoon that are made from pure iron.

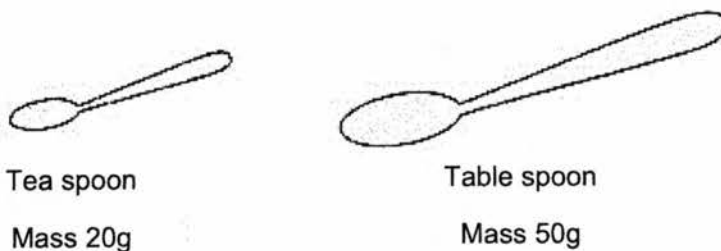

Which of the following statements is correct about the densities of the two types of spoon?

- A Both types of spoon have the same density.
 B The densities of the teaspoon and the tablespoon are 20 g/cm^3 and 50 g/cm^3 respectively.
 C The tablespoon has a higher density than the teaspoon.
 D The teaspoon has a higher density than the tablespoon.
- 9 The diagram below shows a pair of vernier calipers.

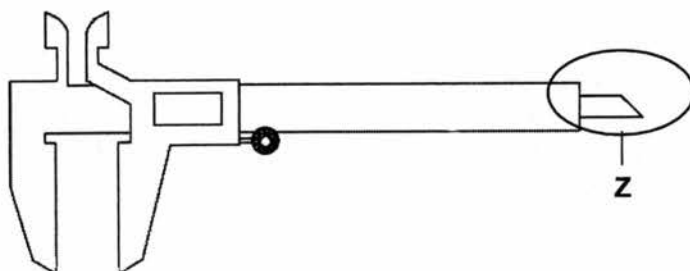

What is a possible use of the part labelled Z?

- A to measure the circumference of a coin
 B to measure the depth of a hole
 C to measure the inner diameter of a tube
 D to measure the thickness of a wire

5

- 10 The diagram below shows the zero error reading on a pair of vernier calipers with closed jaws.

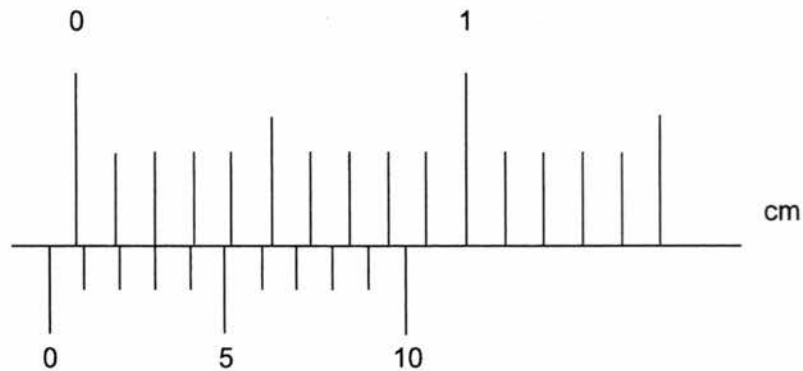

What is the zero error?

- A - 0.07 cm
 B - 0.03 cm
 C + 0.03 cm
 D + 0.07 cm
- 11 The diagrams below show onion cells and human cheek cells examined under a microscope.

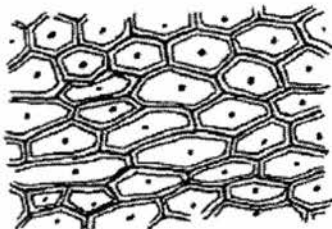

Onion cells

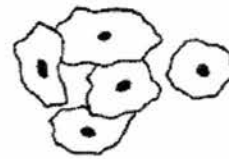

Human cheek cells

Which of the following structures is/are seen in both cells?

- I cell membrane
 II cell wall
 III chloroplast
 IV nucleus
- A I only
 B I and IV only
 C II and III only
 D II and IV only

6

- 12 Which part of the plant cell is responsible for controlling substances entering or leaving the cell?
- A cell membrane
 - B cell wall
 - C chloroplast
 - D vacuole
- 13 Which of the following is an organelle?
- A lung
 - B muscle
 - C nucleus
 - D plant cell
- 14 Which part of the microscope is used to focus and sharpen images?
- A coarse adjustment knob
 - B eyepiece
 - C fine adjustment knob
 - D objectives
- 15 The eyepiece of a microscope has a magnification of 10X. The objective lens has a magnification of 4X.
- What is the total magnification of the microscope?
- A 4X
 - B 10X
 - C 14X
 - D 40X
- 16 Which of the following actions will increase the rate of vibrations of particles in a piece of metal?
- A bending the metal
 - B heating the metal
 - C stretching the metal
 - D stroking the metal with a magnet

- 17 Which of the following statements about matter are **true**?
- I Forces of attraction hold the particles in all solid matter together.
 - II Matter is made up of small discrete particles.
 - III The particles in all matter are the same.
 - IV There are no forces of attraction between gas particles.
- A I and II only
B II and III only
C II and IV only
D I, II and III
- 18 Pollen grains suspended in water appear to move on their own. Which of the following statements correctly explains this observation?
- A The pollen grains collide with dissolved gas particles from the air.
B The pollen grains collide with one another.
C The pollen grains collide with the water particles.
D The water particles move towards an area of low concentration.
- 19 What happens to the particles of an object during freezing?
- A decrease in speed and move closer together
B decrease in speed and move further apart
C increase in speed and move closer together
D increase in speed and move further apart
- 20 Which of the following substances contains particles that move the **fastest** at 28 °C?
- A ice
B oxygen
C petrol
D water
- 21 Gas particles at room temperature are able to move at very high speeds. However, when a bottle of perfume is opened at the end of a large room, it might take several minutes before its smell can be detected at the other end.
- Which of the following explains this phenomenon?
- A Perfume particles move slower than the gas particles in the air.
B Random collisions occur among perfume particles.
C Random collisions occur between perfume particles and gas particles.
D Strong attractive forces exist between perfume particles and gas particles.

22 Which of the following statements about boiling water is **incorrect**?

- A The forces of attraction between water particles become weaker.
- B The spaces between the water particles increase.
- C The water particles changes into a state with no definite volume.
- D The water particles expand.

23 The table below shows the melting points and boiling points of five different substances P, Q, R, and S.

Substance	Melting point / °C	Boiling point / °C
P	95	280
Q	24	74
R	-26	37
S	31	140

Which substance(s) would be a solid at 22 °C but is a liquid at 100 °C?

- A P only
 - B P and Q
 - C P and S
 - D P, Q and R
- 24 Which diagram shows the arrangement of particles inside a balloon filled with a mixture of helium and argon?

◦ helium atom
○ argon atom

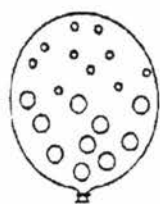

A

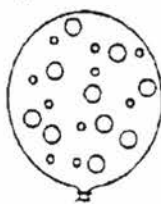

B

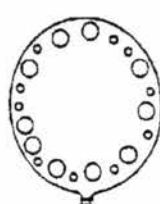

C

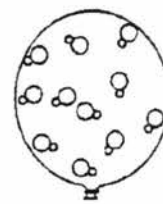

D

25 Which of the following will expand the **least** in volume when its temperature rises by 5 °C?

- A 100 cm³ of hydrogen
- B 100 cm³ of oil
- C 100 cm³ of water
- D 100 cm³ of wood

- 26 A freshly baked cake is placed on a table. Which of the following describes the way the cake loses heat?
- A by conduction only
 B by convection only
 C by conduction and convection
 D by conduction, convection and radiation
- 27 Four spoons of different materials were used to stir an equal amount of boiling water in a pot. Which spoon will heat up **most** quickly?

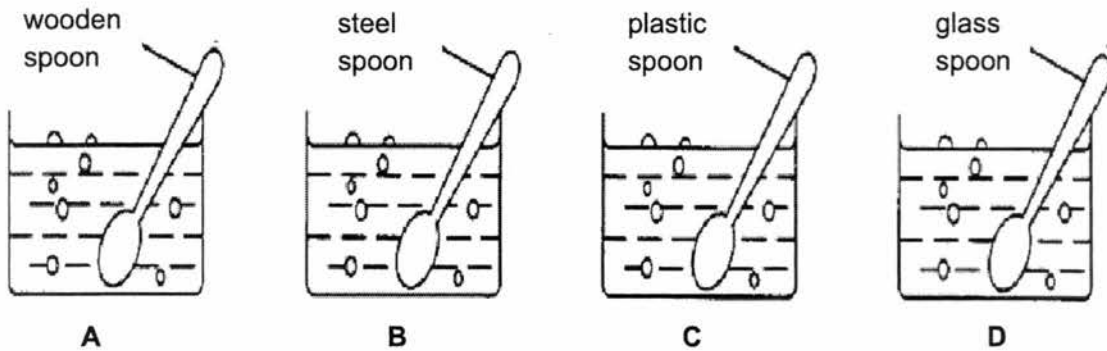

- 28 An experimental setup is shown in the diagram below. The glass rod and the copper rod are of equal lengths. Each pin is attached to a rod with an equal amount of wax.
- Which pin will drop off **last**?

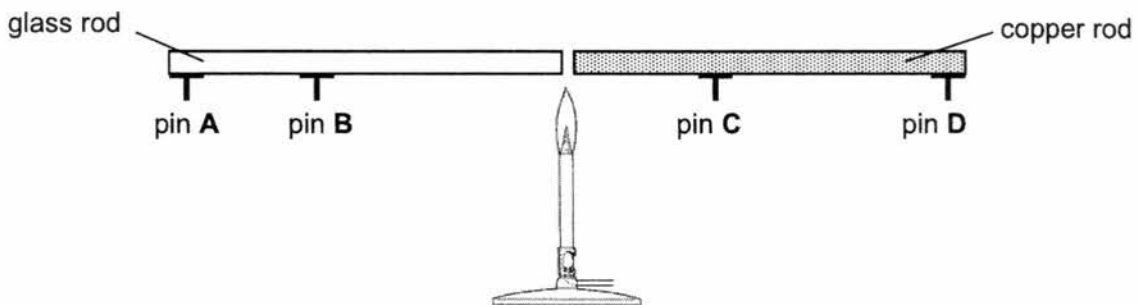

- 29 Which of the following statements about radiation is **incorrect**?
- A Black surfaces are good emitters of radiation.
 B Objects with higher temperature emit radiation at a lower rate.
 C Objects with larger surface area absorb radiation at a higher rate.
 D Radiation can travel through a vacuum.

10

- 30 Which of the following diagrams shows the correct direction of the convection current set up in the box?

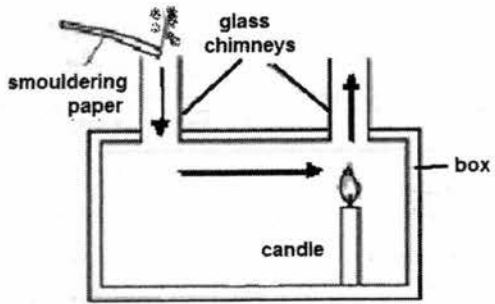

A

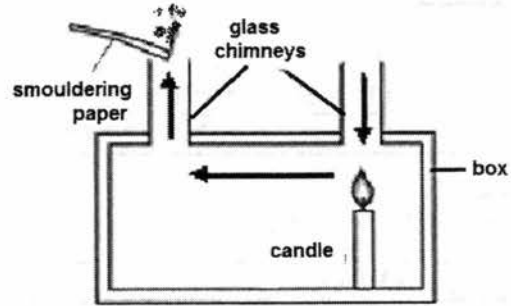

B

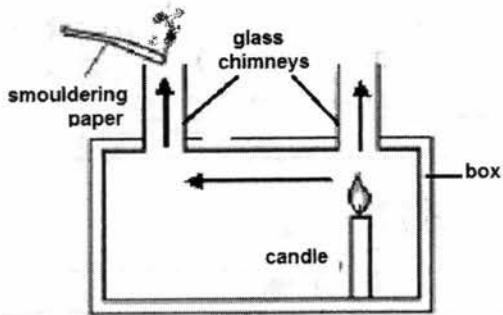

C

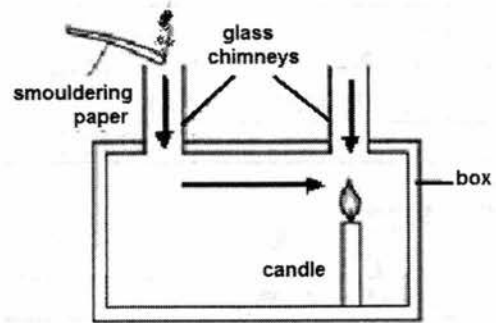

D

Section B [40 marks]

Answer *all* questions in this section in the space provided.

- 1 (a) Fig. 1.1 shows a scene inside a science laboratory.

For Examiner's Use



Fig. 1.1

State two **unsafe** actions shown in the situation above and suggest what should be done instead.

	Unsafe action	What should be done
1.	<p>.....</p> <p>.....</p> <p>.....</p> <p>.....</p> <p>.....</p> <p>.....</p> <p>.....</p>	<p>.....</p> <p>.....</p> <p>.....</p> <p>.....</p> <p>.....</p> <p>.....</p> <p>.....</p>
2.	<p>.....</p> <p>.....</p> <p>.....</p> <p>.....</p> <p>.....</p> <p>.....</p> <p>.....</p>	<p>.....</p> <p>.....</p> <p>.....</p> <p>.....</p> <p>.....</p> <p>.....</p> <p>.....</p>

[4]

- (b) Table 1.1 shows the results from an experiment.

For Examiner's
Use

Table 1.1

Test	Volume of water / cm ³	Number of similar ice cubes	Temperature of water / °C	Time taken for the ice cubes to melt completely / s
A	20	4	30	40
B	20	4	40	30
C	20	4	50	20
D	20	5	60	25

- (i) State the hypothesis of this experiment.

.....
 [1]

- (ii) Which of the test results **cannot** be used for the conclusion? Give a reason.

.....
 [2]

[Total: 7]

2 Fig. 2.1 shows a Bunsen burner.

For Examiner's Use

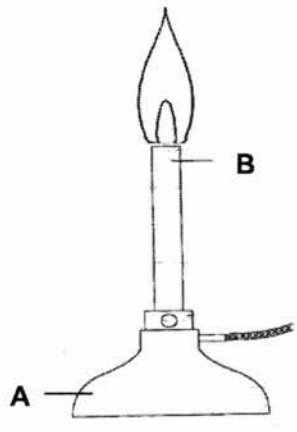

Fig. 2.1

(a) Label parts **A** and **B** of the Bunsen burner.

A: **B:** [2]

(b) State the functions of parts **A** and **B**.

Function of **A:**
.....

Function of **B:**
..... [2]

(c) Label the hottest point of the flame with the letter '**X**' on **Fig. 2.1**.

[1]

(d) Sam needs to boil a beaker of water during an experiment. Draw the scientific diagram and name the lab apparatus which he will use to support the beaker during heating when conducting the experiment.

Drawing of lab apparatus	
Name of lab apparatus drawn

[2]

[Total: 7]

3 (a) Fig. 3.1 shows a \$1 coin.



Fig. 3.1

Samantha decided to use a pair of vernier calipers to measure the diameter of the \$1 coin. The measurements are shown in Fig. 3.2.

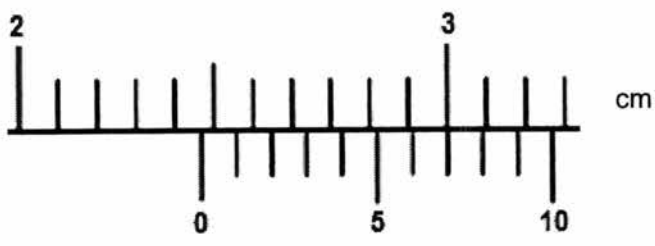

Fig. 3.2

(i) State the diameter of the \$1 coin.

Diameter of the \$1 coin: cm [1]

(ii) Suggest why the pair of vernier calipers is a more suitable measuring instrument than the ruler.

..... [1]

(b) Write down the S.I. units for the following physical quantities.

Physical quantity	S.I. unit
mass	
temperature	

[2]

[Total: 4]

For Examiner's Use

4 Cheryl wanted to find the density of an unknown substance **P**.

- (a) Cheryl used an electronic balance shown in Fig. 4.1 to find the mass of substance **P**. She saw that the reading on the instrument was 0.30 g before putting substance **P** on it.

For Examiner's
Use

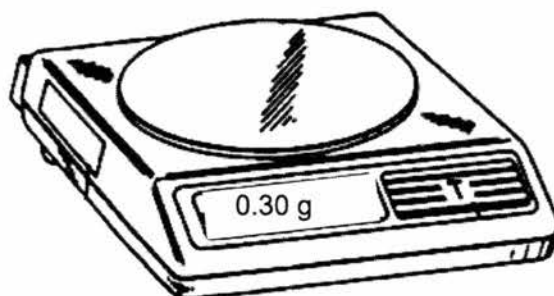

Fig. 4.1

- (i) State the step that Cheryl should take before using the electronic balance.

.....

[1]

- (ii) If Cheryl did not take the step in a(i) and obtained a reading of 137.50 g, what should be the corrected reading for the mass of substance **P**?

.....

[1]

- (b) Cheryl then used a measuring cylinder to find the volume of substance **P**. She filled the measuring cylinder with 30 cm³ of water and saw that the water level rose to the level as shown in Fig. 4.2.

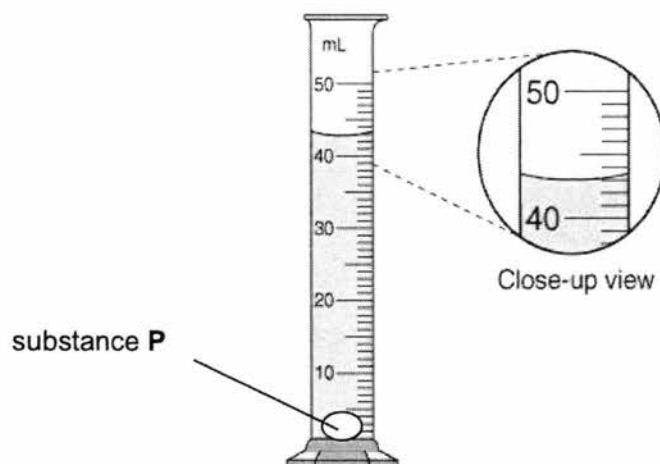

Fig. 4.2

16

What is the volume of substance P?

Volume of substance P = cm³ [1]

For Examiner's Use

(c) Calculate the density of substance P.

Density = g/cm³ [2]

(d) Table 4.1 shows the densities of several common substances.

Table 4.1

Substance	Density (g/cm ³)
Glass	2.50
Aluminum	2.70
Diamond	3.21
Titanium	4.43
Iron	7.87
Copper	8.96
Silver	10.49
Lead	11.36

(i) Using Table 4.1, suggest a possible identity of substance P.
..... [1]

(ii) State how substance P will behave if it is dropped into a bowl of water (density of water = 1 g/cm³).
.....
..... [1]

[Total: 7]

- 5 (a) Describe how the particles of water and oxygen differ in their **movement** and **arrangement** at room temperature and pressure.

For Examiner's Use

	Water	Oxygen
Movement
Arrangement

[4]

- (b) Explain why solids have a definite shape.

.....
.....

[1]

[Total: 5]

6 Fig. 6.1 shows two experimental set-ups, X and Y. The air inside both round-bottomed flasks is initially at 90 °C. An ice bag is placed on top of the round-bottomed flask in set-up X. The set-ups are left alone for 30 minutes.

For Examiner's Use

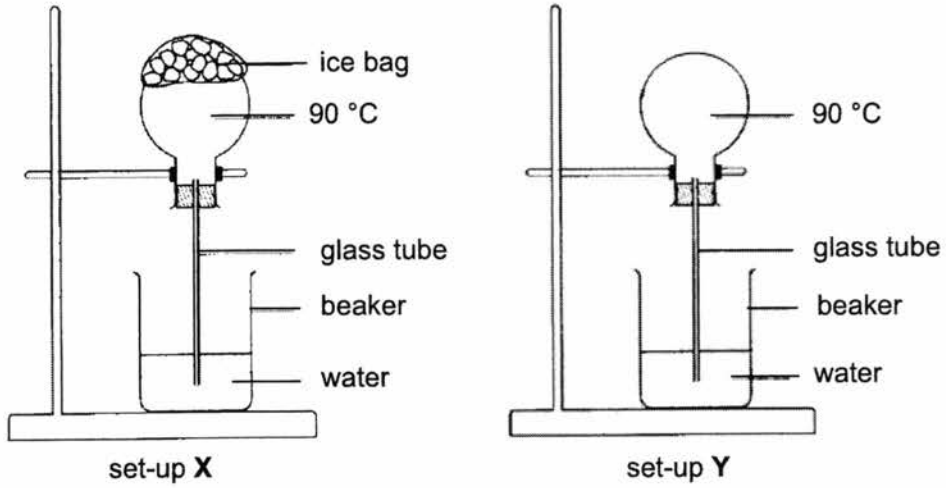

Fig. 6.1

(a) After 30 minutes, which set-up (X or Y) would have a **higher** water level in the glass tube?

Set-up:

[1]

(b) Explain your answer in part (a).

.....

[2]

[Total: 3]

- 7 Fig. 7.1 shows two beakers of water, beaker **A** and beaker **B**. Each beaker contains an ice cube. The ice cube in beaker **A** is wrapped in wire gauze, which keeps it at the bottom of the beaker at all times.

For Examiner's
Use

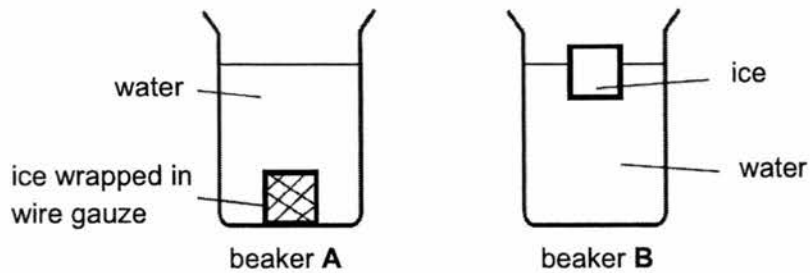

Fig. 7.1

- (a) By which method of heat transfer is the water in the beaker **B** cooled?

..... [1]

- (b) Explain why ice, when placed at the bottom of the beaker **A**, does **not** cool the water as effectively as when it is floating on the water.

.....

 [2]

[Total: 3]

8 Explain the following.

For Examiner's Use

(a)

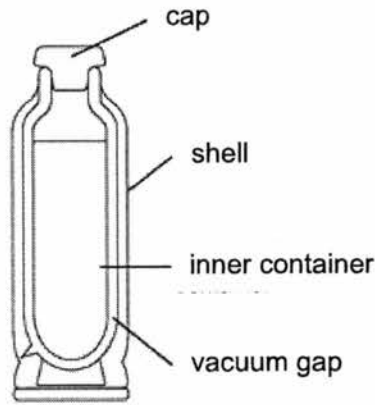

Fig. 8.1

In a vacuum flask, there is a vacuum gap between the inner container of hot water and the other shell as shown in Fig. 8.1.

.....
.....
.....

[2]

(b) A cement floor is cooler to the touch than a carpet floor, even though both are at the same temperature.

.....
.....
.....

[2]

[Total: 4]

Section C [30 marks]

Answer **all** questions in this section in the space provided.

- 9 (a) Fig. 9.1 below shows a cell.

For Examiner's
Use

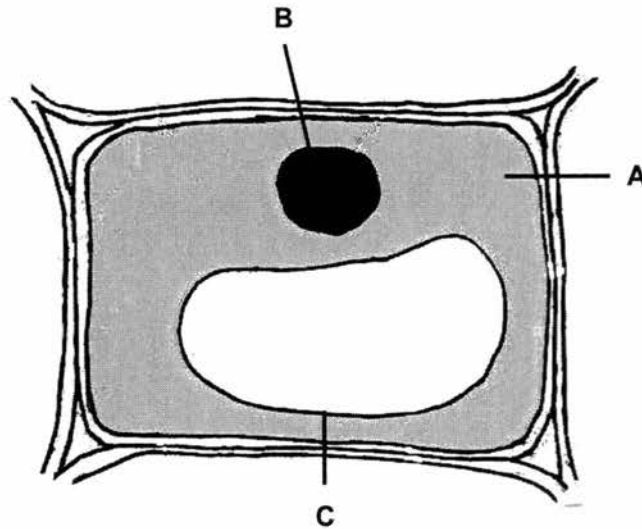

Fig. 9.1

- (i) Name the parts of the cell labelled **A** and **B**.

A: **B:** [2]

- (ii) State the main function of the cell part labelled **C**.

..... [1]

- (iii) Is the cell in **Fig. 9.1** an animal cell or plant cell? Give a reason to explain your answer.

..... [2]

- (b) The amoeba is a unicellular organism which can be found in a pond.

- (i) Explain the term '*unicellular organism*'.

..... [1]

- (ii) Name the instrument which can be used to observe unicellular organisms.

..... [1]

(c) The human body is made up of many specialised cells. In multicellular organisms, these cells carry out division of labour.

For Examiner's Use

(i) Name an advantage of division of labour within an organ.

.....
.....

[1]

(ii) Complete the diagram below to show how cells are organised in a multicellular organism.



[2]

[Total: 10]

- 10 (a) (i) Sketch the arrangement of particles in the following physical states in Fig. 10.1.
 (Use ○ to represent a particle.)

For Examiner's Use

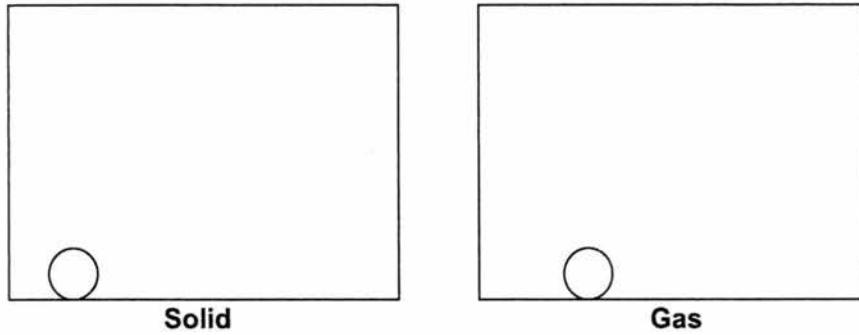

[4]

Fig. 10.1

- (ii) Explain why liquids **cannot** be compressed.

.....

[1]

- (b) Ken took out a small container of ice cream from the freezer.

- (i) Describe the movement of particles in the frozen ice cream.

.....

[1]

- (ii) What happens when the ice cream is left on the table for two hours?

.....

[1]

- (iii) Using the particulate nature of matter, explain what happened in part (b)(ii).

.....

[3]

[Total: 10]

11 Fig. 11.1 shows a solar panel used to heat water. Fig. 11.2 shows the cross-sectional diagram of the copper pipe.

For Examiner's Use

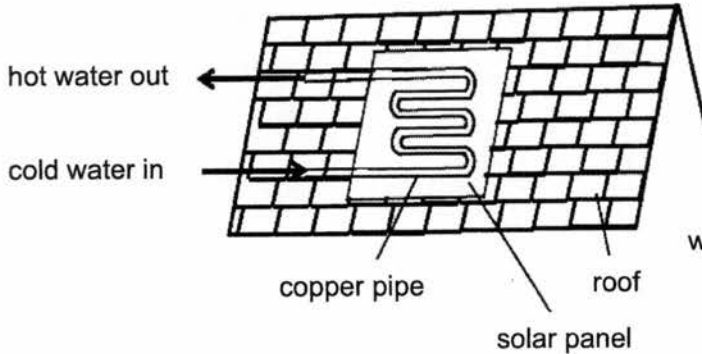

Fig. 11.1

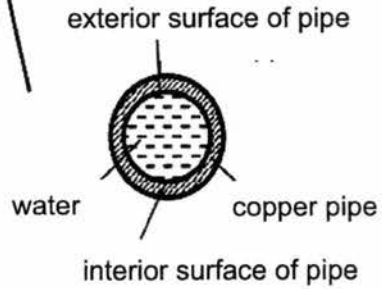

Fig. 11.2

- (a) (i) State the mode of heat transfer from the sun to the exterior surface of the pipe in the solar panel.
 [1]
- (ii) Why are the solar panel and copper pipes painted black?
 [1]
- (b) (i) State the mode of heat transfer from the exterior surface of the copper pipe to the interior surface.
 [1]
- (ii) Using the particulate theory of matter, explain how heat is transferred from the exterior surface of the copper pipe to the interior surface.
 [3]
- (c) Why are there bends in the structure of the copper pipe?
 [2]

25

(d) State one advantage and one disadvantage of using solar panels to heat up water.

For Examiner's Use

Advantage:

..... [1]

Disadvantage:

..... [1]

[Total: 10]

End of Paper

MID-YEAR EXAMINATION 2017
Science Secondary 1 Express
Marking Scheme

Section A: MCQ (30 MARKS)

1	A	11	B	21	C
2	D	12	A	22	D
3	A	13	C	23	C
4	D	14	C	24	B
5	C	15	D	25	D
6	C	16	B	26	D
7	A	17	A	27	B
8	A	18	C	28	A
9	B	19	A	29	B
10	A	20	B	30	A

Section B: Structured Questions (40 MARKS)

Note: Deduct **1 m** from the whole paper if student did not state the correct units/significant figures under penalty.

Question	Answers	Marks	Remarks
1(a)	<p><i>Unsafe practice:</i></p> <ol style="list-style-type: none"> 1. Girl is <u>not paying attention</u> while conducting her experiment / a measuring cylinder with a substance inside is knocked over 2. Boy is pointing the heated test tube towards his classmate / the girl 3. Table top is <u>messy</u>: loose paper may be a fire hazard 4. Safety goggles are not worn 5. Test tubes are not placed in test tube rack 6. Long hair is not tied up <p><i>What should be done instead:</i></p> <ol style="list-style-type: none"> 1. Students should <u>always</u> stay alert or work thoughtfully / purposefully 2. He should point the test tube away from his classmate 3. Table top should be organized neatly / Any loose paper should be kept away 4. Safety goggles should be worn at all times when conducting an heating experiment 5. Test tubes should be <u>placed in a test tube rack</u> for safekeeping 6. Long hair should be tied up when in the lab 	[4]	<p>1 m – 1 correctly filled blank</p> <p>No mark is awarded when apparatus is named wrongly in explanation e.g test tube holder instead of test tube rack.</p>
1(b)	(i) The <u>higher the water temperature</u> , the <u>shorter the time</u> taken for or <u>faster</u> the ice cubes to melt completely	[1]	
	(ii) Test D Number of ice cubes is not the same / not kept constant	[1]	

Marker's comments:

1a) common mistakes - test tubes are to be placed in test tube rack, not test tube holders.

1b)i) Many of them did not suggest higher temperature how it affects the time taken or rate of melting. You cannot simply state the hypothesis as temperature of water affecting the time taken only.

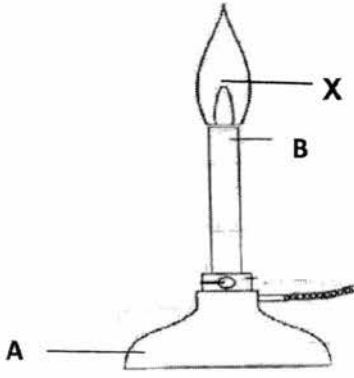
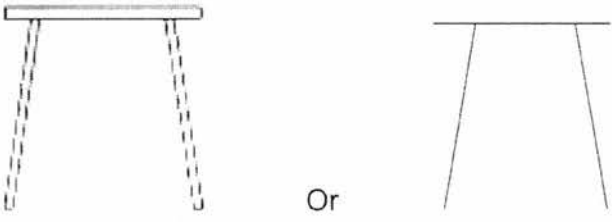
1bii) Most of the students did well.			
2(a)	A: Base B: Barrel	[1] [1]	
2(b)	A: To support the burner so that it will not fall over B: To allow the flame to be at a suitable height for burning	[1] [1]	
2(c)		[1]	
2(d)	 <p style="text-align: center;">Or</p> <p style="text-align: center;">Tripod stand</p>	[1] [1]	Drawing : Clean lines Proportionate size Drawing must be 2D
Marker's comments:			
2a) Some students mixed up the answers to A and B ; Some did not revise the parts of Bunsen burner and gave strange answers.			
2b) A: many of them wrote 'support the burner', some wrote 'hold the burner'. B: Not many have written the expected answer for barrel.			
2c) Some labelled X at below the tip of the inner cone. Some did not label/did not attempt totally.			
2d) some drew 3D, a few used pen to draw; a few drew the complete set up including the beaker and Bunsen flame. A few stated 'tripod' as the name of the apparatus. Some wrote retort stand.			
3(a)	(i)	Diameter of the \$1 coin: 2.47 cm	[1]
	(ii)	Vernier calipers can read up to 0.01 cm or 2	

		<u>decimal places</u> compared to 0.1 cm or 1 decimal place for a ruler. Vernier calipers is <u>more precise</u> in measuring the length.	[1]					
3(b)	Mass: kg Temperature: K		[1] [1]					
Marker's comments:								
3ai) Some could not read the Vernier calipers correctly.								
3aii) Many of them wrote Vernier calipers is more accurate which is not a good answer.								
3b) A few wrote grams or both grams and kilograms as answers. No marks were awarded. A few wrote degree Celsius for temperature.								
4(a)	(i)	Press the zero / tare button to zero or reset the balance	[1]	A Reset				
	(ii)	137.20 g	[1]	To 2 d.p.				
4(b)		13	[1]					
4(c)		Density = Mass / Volume = 137.20 g / 13.0 cm ³ = 10.6 g / cm ³	[1] [1]	Allow ecf To 3 s.f.				
4(d)	(i)	Silver	[1]	Allow ecf				
	(ii)	It will sink	[1]					
Marker's comments:								
4ai) Most of the students did not get the mark. Many of them did not mention about pressing the zero button or state to zero or reset the balance. Students should not state 'ensure' the balance is at 0 g or 'adjust' or 'restart' the balance.								
4aii) A few wrote 137.2 g or wrote answer without the unit. They were penalised for decimal place or unit.								
4b) Many of them did not read the question carefully and wrote 43 as the answer.								
4c) Many of them were penalised for leaving the answers in more than 3 s.f. Many were awarded error carried forward mark due to mistakes in part b.								
4di) and 4dii) Most of the students were awarded the mark.								
5(a)	<table border="1"> <tr> <td><u>Movement (Water)</u> Particles are able to <u>slide</u> <u>past</u> one another</td> <td><u>Movement (Oxygen)</u> Particles <u>move about</u> <u>freely</u> at <u>high speeds</u> in <u>all directions</u></td> </tr> <tr> <td><u>Arrangement (Water)</u> Particles are <u>packed</u> <u>closely</u> together in a</td> <td><u>Arrangement (Oxygen)</u> Particles are <u>far apart</u> from each other in a</td> </tr> </table>		<u>Movement (Water)</u> Particles are able to <u>slide</u> <u>past</u> one another	<u>Movement (Oxygen)</u> Particles <u>move about</u> <u>freely</u> at <u>high speeds</u> in <u>all directions</u>	<u>Arrangement (Water)</u> Particles are <u>packed</u> <u>closely</u> together in a	<u>Arrangement (Oxygen)</u> Particles are <u>far apart</u> from each other in a		1 m – 1 correctly filled blank
<u>Movement (Water)</u> Particles are able to <u>slide</u> <u>past</u> one another	<u>Movement (Oxygen)</u> Particles <u>move about</u> <u>freely</u> at <u>high speeds</u> in <u>all directions</u>							
<u>Arrangement (Water)</u> Particles are <u>packed</u> <u>closely</u> together in a	<u>Arrangement (Oxygen)</u> Particles are <u>far apart</u> from each other in a							

	<u>random arrangement</u>	<u>random arrangement</u>	[4]	
5(b)	Particles in solids are <u>in fixed positions</u> and cannot move around freely		[1]	
Marker's comments:				
5a) For movement: some did not mentioned moving at high speed for oxygen, For arrangement: Many just stated packed closely together for water and further apart for oxygen.				
5b) Some did not mentioned about fixed position and unable to be awarded the mark.				
6(a)	X		[1]	
6(b)	The ice bag will cool the air in the flask of set-up X <u>more than</u> that of set-up Y The cooler air <u>contracts more</u> , <u>more water enters the glass tube</u> to fill up the space, so the water level in set-up X is higher.		[1]	
			[1]	
Marker's comments:				
6a) Some awarded mark, some didn't.				
6b) For those who chosen X in 6a, they were unable to state the expected reasons. Some thought that the flask contracted and did not mentioned about the contraction of air and spaces that allow water to enter. Some wrote about set Y which has expansion of flask or air taking place and hence allow spaces to let water to fill in.				
7(a)	Convection		[1]	
7(b)	The cooled water contracts, becomes denser, and remains at the bottom As such, it is not possible to set up convection current to cool water effectively		[1]	
			[1]	
Marker's comments:				
7a) Some wrote conduction or radiation instead of convection.				
7b) Few students are able to produce the correct answers. Many of them explain about what happened in beaker B which is not required.				
8(a)	The vacuum gap <u>prevents/stops heat loss or heat transfer</u> from the hot water via <u>conduction</u> and <u>convection</u>		[1]	1m for: - only conduction or convection stated - only state reduce heat loss
			[1]	

8(b)	<u>Cement is a better conductor</u> than carpet (or air trapped by the carpet)	[1]	
	The cement floor will <u>conduct heat away from the hand</u> more quickly than a carpet floor	[1]	

Marker's comments:

8a) Most students did not answer this question completely. Some thought air is found inside vacuum. Some did not know that the process such as conduction and convection should be mentioned in the answer.

8b) Some wrote that the cement are poor conductor or good reflector. Most students did not understand heat is conducted away from the hand so that we will feel cool. Most students did not know they need to state the comparison of the two materials.

Section C: Free Response Questions (30 MARKS)

9(a)	(i)	A: cytoplasm B: nucleus	[1] [1]	
	(ii)	C: <u>Store</u> water / food / wastes / other materials needed by the cell	[1]	
	(iii)	Plant cell Presence of cell wall / <u>one central large</u> vacuole	[1] [1]	
9(b)	(i)	An organism with only one / single cell	[1]	
	(ii)	Microscope	[1]	
9(c)	(i)	Function efficiently	[1]	
	(ii)	<pre> graph LR cells[cells] <--> tissues[tissues] tissues <--> organs[organs] organs <--> organ_systems[organ systems] </pre>	[2]	1 m – 1 correctly filled blank

Marker's comments:

9a) Quite ok. Most students identified **B** correctly but not **A**.

9b) Generally well done. Accepted 'contain' instead of 'store'.

9c) Quite well done. Most students managed to identify the cell as plant cell. However, some of them lost marks as they mention "one large" vacuole only. Some of them thought the cell is an animal cell as chloroplasts are absent from the diagram.

9d) (i) Quite ok. Some students wrote that it contains one type of cell. They need to know that containing one type of cell does not mean it contains 1 single cell. One type of cells can be formed by many cells of the same type.

9d) (ii) Generally well done.

9e) (i) Poorly attempted. Some of them thought 'division of labour' is cell division. A

number of them stated the meaning of 'division of labour' instead of giving the advantage.

9e) (ii) Quite ok. Some of them gave muscle instead of organs. They seemed to think that the question is asking for an example of organs or misunderstood that muscle is a general term used for organs.

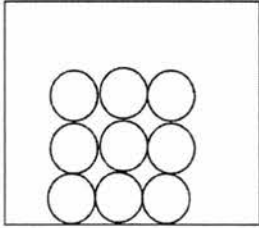
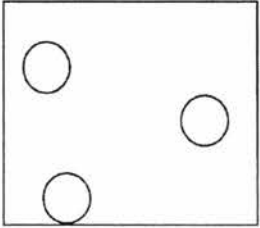
10 (a)	(i)	<p>Solid</p>  <p>Gas</p>  <p>Solid – min 6 circles, regularly arranged in layers, all circles touching. [2]</p> <p>Gas – min 3 circles drawn, spread out across the box and far apart. [2]</p>		For each drawing, deduct 1 m for every mistake.
	(ii)	<p>Particles in liquids are <u>closely packed</u> / have no space to move into [1]</p>		
10 (b)	(i)	<p>Particles are <u>vibrating about their fixed positions</u> [1]</p>		R move
	(ii)	<p>It melts / turn into liquid state [1]</p>		
	(iii)	<p>The solid particles in the ice cream <u>gain heat energy</u> and <u>vibrates more rapidly</u> [1] Heat energy is used to <u>overcome the attractive forces</u> between the solid particles [1] Particles are now further apart and able to <u>move around freely</u>. The solid ice cream melts to its liquid state [1]</p>		

Marker's comments:

10a) (i) Quite ok. Some students drew the solid particles a little too far apart while for the gas particles a little too many and too close together. A number of students were penalised due to difference in the particle size drawn.

10a) (ii) Quite ok. Some students gave answers like definite volume which does not explain why liquids cannot be compressed.

10b) (i) Generally ok. Many students stopped at vibrating and did not mention fixed positions. Their answer is also rejected if they use 'move' instead of 'vibrate'.

10b) (ii) Poorly attempted. Many did not mention that solid particles need to gain heat

energy first before they can vibrate more rapidly. Quite a number did not show the comparison between the speed of vibration of the particles before and after gaining heat energy. Many failed to realise the importance of stating 'move around freely' to explain the change of states from solid to liquid. They stopped at 'particles are now further apart' which also happens during expansion.

11 (a)	(i)	Radiation	[1]	
	(ii)	Black surfaces are good absorbers of radiation	[1]	
11 (b)	(i)	Conduction	[1]	
	(ii)	Heat from the sun causes the particles at the exterior surface to <u>vibrate more rapidly</u> These particles <u>collide with the neighbouring/ surrounding particles</u> until the particles at the interior surface also <u>increases the speed of vibration</u>	[1] [1] [1]	
11 (c)		The bends <u>allow the copper pipe to expand</u> on a hot day <u>without damage/bursting</u> OR The bends <u>increase the surface area exposed</u> for the absorption of <u>radiation</u> from the sun	[1] [1]	
11 (d)		Advantage: Renewable/ sustainable/ reduces electricity costs/ silent /low maintenance/ more environmentally friendly (Any one)	[1]	
		Disadvantage: Expensive/ Intermittent / Require space (Any one)	[1]	

Marker's comments:

- (a) (i) Generally okay. Some students are unable to state the correct mode of heat transfer.
(ii) Most students stated heat instead of radiation. It is accepted this time round.
- (b) (i) Many students are unable to state the correct mode of heat transfer.
(ii) Very poorly done. Most students did not use the particle theory to explain and those who attempted are unable to explain heat transfer by conduction fully.
- (c) Generally okay. A number of students mentioned that the bends prevent the damage of the pipes but never mentioned what is the cause of the damage that can be avoided.
- (d) Generally okay. For advantages, accept: "save electricity/ energy/ money". For

disadvantages, accept "cannot be used at night/ without sunlight/ on rainy day" (intermittent).

End of Marking Scheme