

*Visit*

**FREETESTPAPER.com**

*for more papers*



Website: [freetestpaper.com](http://www.freetestpaper.com)



[Facebook.com/freetestpaper](https://www.facebook.com/freetestpaper)



[Twitter.com/freetestpaper](https://www.twitter.com/freetestpaper)



PASIR RIS CREST SECONDARY SCHOOL  
End of Year Examination  
Secondary One Express

CANDIDATE  
NAME

CLASS

	/	
--	---	--

INDEX  
NUMBER

--	--

## Science (Physics/ Biology)

Paper 1

9 October 2017

Papers 1, 2 and 3: 2 hours

Additional material: Multiple Choice Answer Sheet

### READ THESE INSTRUCTIONS FIRST

Do not open this booklet until you are told to do so.

Do not use staples, paper clips, highlighters, glue or correction fluid.  
Write your name, class and register number on the answer sheet in the spaces provided.

There are **thirty** questions on this paper. Answer all questions. For each question, there are four possible answers **A, B, C** and **D**.  
Choose the one you consider correct and record your choice in **soft pencil** on the separate Answer Sheet.

**Read the instructions on the Answer Sheet very carefully.**

Each correct answer will score one mark. A mark will not be deducted for a wrong answer.  
Any rough working should be done in this booklet.

<b>For Examiner's Use</b>
<b>30</b>
<b>Parent's Signature</b>

- 16 A student wanted to investigate if temperature of the surroundings will affect the increase in length of a certain type of water plant. He set up the experiment as shown below.

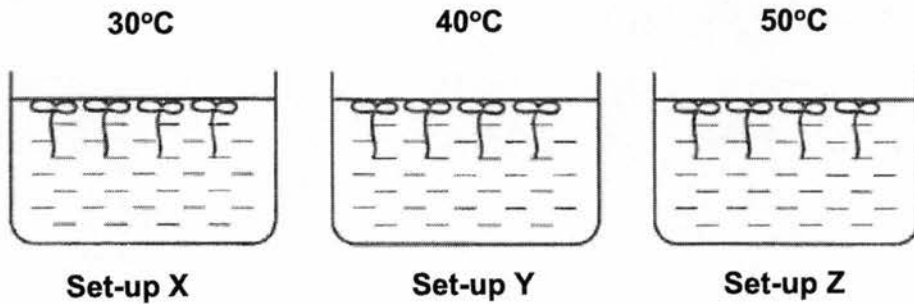

Identify the variable that was changed in the experiment.

- A Type of water plant used.  
 B Number of water plants used  
 C Average temperature of the surroundings  
 D Average increase in the length of the water plants
- 17 The table below shows some characteristics of four types of cells.

Which cells could be a root hair cell?

	Nucleus	Chloroplast
<b>A</b>	Present	Absent
<b>B</b>	Absent	Absent
<b>C</b>	Present	Present
<b>D</b>	Absent	Present

- 18 The diagram shows a plant cell. In which part of the cell is glucose made?

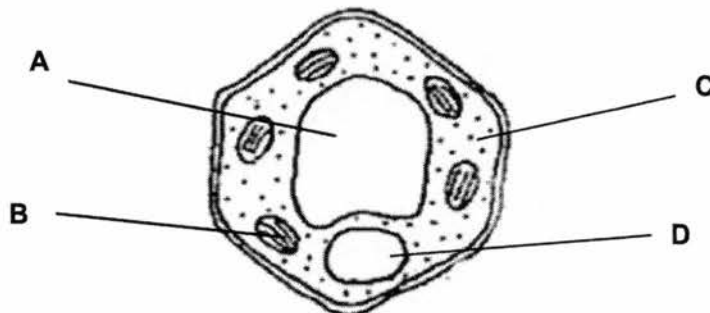

- 19 The diagram shows four possible pathways for the transfer of energy from green plants to Man.

Which pathway shows green plants transferring the **least** energy to Man?

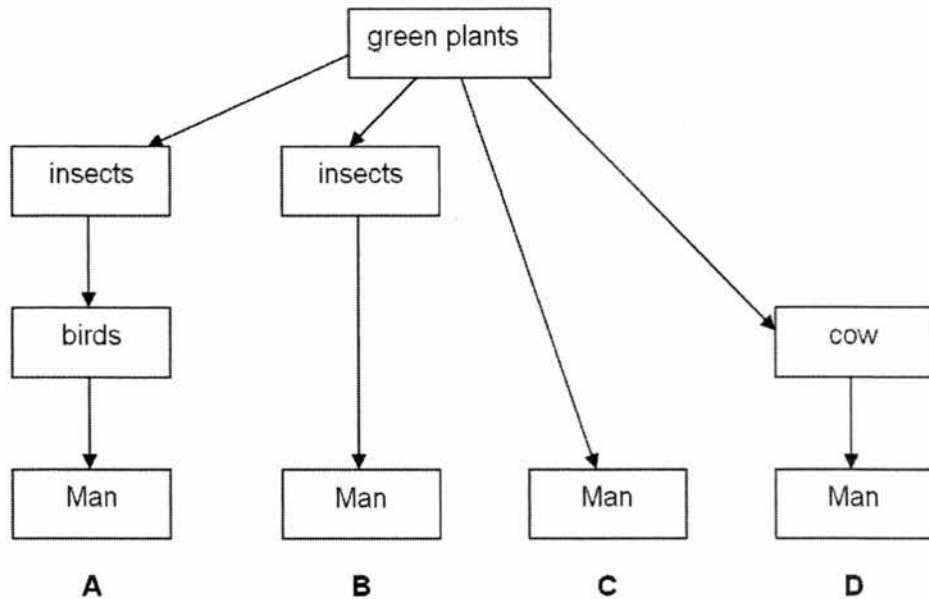

- 20 The diagram below shows a food web in a wetlands ecosystem

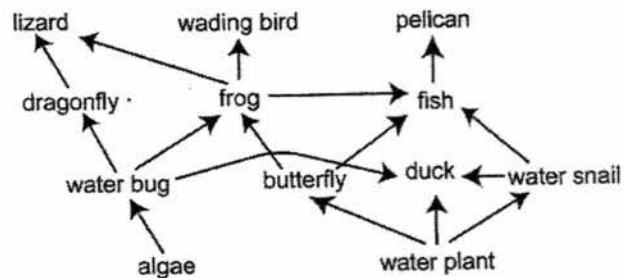

Which of the following organisms is both a primary and a secondary consumer?

- |   |  |
|---|--|
| <p><b>A</b> frog</p> <p><b>C</b> lizard</p> | <p><b>B</b> duck</p> <p><b>D</b> butterfly</p> |
|---|--|
- 21 Which of the following is an example of something we can do to protect and conserve biodiversity?
- A** clear land for development of a shopping centre
  - B** leave the fans in the room on as we are returning later
  - C** buy products made from recycled materials
  - D** treat your family with a meal including shark's fin soup

- 22 A leafy shoot is placed in a blue dye solution.



Which part of the plant becomes stained by the blue dye **first**?

- A Xylem vessels in the leaves.
  - B Xylem vessels in the stem.
  - C Phloem cells in the leaves.
  - D Phloem cells in the stem.
- 23 Which of the features helps plants to make the most food by photosynthesis?

- A broad and flat green leaves
- B broad and flat variegated leaves
- C red coloured leaves
- D spiky green leaves

- 24 Which of the following statements is not true about the human vena cava?

- A It carries blood to the heart muscle.
- B It carries deoxygenated blood.
- C It has a thin muscular wall.
- D It has valves.

- 25 The diagram below shows a section of the human heart.

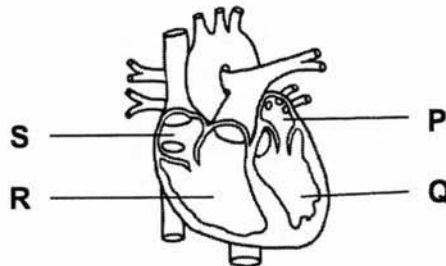

Which chambers contain deoxygenated blood?

- |   |         |   |         |
|---|---------|---|---------|
| A | P and Q | B | Q and R |
| C | P and S | D | R and S |

26 When the right atrium contracts, blood flows from the right atrium into the \_\_\_\_\_.

- A aorta
- B left atrium
- C pulmonary artery
- D right ventricle

27 Which of the following occurs as a result of respiration?

	carbon dioxide produced	oxygen used	water produced
<b>A</b>	yes	no	no
<b>B</b>	yes	yes	yes
<b>C</b>	no	no	yes
<b>D</b>	no	yes	no

28 In which conditions will a plant photosynthesise fastest?

	carbon dioxide concentration / %	temperature / °C
<b>A</b>	0.04	15
<b>B</b>	0.04	25
<b>C</b>	0.01	15
<b>D</b>	0.01	25

29 The diagram shows someone blowing up a balloon.

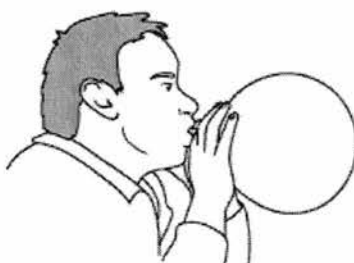

How do the proportions of gases in the air inside the balloon compare with the air outside the balloon?

	carbon dioxide	oxygen	water vapour
<b>A</b>	less	more	more
<b>B</b>	less	more	less
<b>C</b>	more	less	more
<b>D</b>	more	less	less

- 30 A patient in a hospital is suffering from a disease which causes organ **X** to malfunction. Which of the following is a possible problem the patient would face?

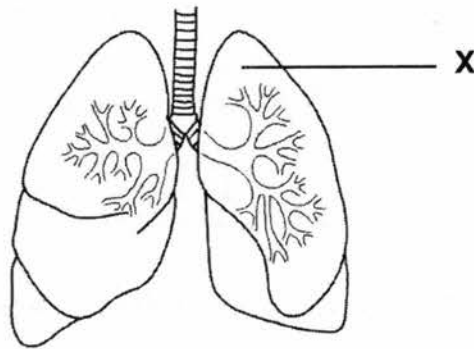

- A** Food will not be digested efficiently
- B** Oxygenated and deoxygenated blood will be mixed
- C** Exchange of gases between the organ and air will become reduced
- D** Unable to pump blood around the body

**End of Paper**



PASIR RIS CREST SECONDARY SCHOOL  
End of Year Examination  
Secondary One Express

CANDIDATE  
NAME

CLASS

	/	
--	---	--

INDEX  
NUMBER

--	--

## Science (Biology)

Paper 3

9 October 2017

Paper 1, 2 and 3: 2 hours

### READ THESE INSTRUCTIONS FIRST

Write your candidate name, class and index number on all the work you hand in.  
Write in dark blue or black pen.  
You may use an 2B pencil for any diagrams or graphs.  
Do not use staples, paper clips, glue or correction fluid.

### Section A (15 marks) and Section B (20 marks)

Answer **all** questions.

Write your answers in the spaces provided on the question paper.

The number of marks is given in brackets [ ] at the end of each question or part question.

<b>For Examiner's Use</b>
<b>35</b>
<b>Parent's Signature</b>

**Section A: Structured Questions (15 marks)**

1. Fig 1.1 shows some human muscle tissue.

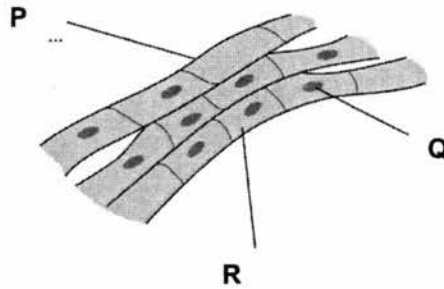
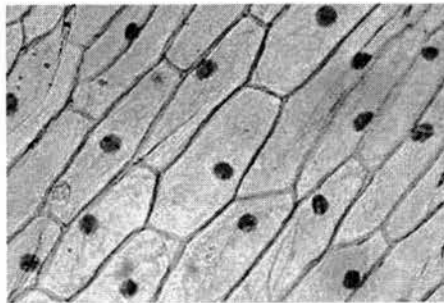

**Fig 1.1**

(a) Name the parts P, Q and R of the muscle cells. [2]

P \_\_\_\_\_  
Q \_\_\_\_\_  
R \_\_\_\_\_

Fig. 1.2 below shows a photomicrograph of onion epidermal cells.



**Fig. 1.2**

(b) With reference to Fig. 1.1 and Fig. 1.2, describe one way in which the muscle cells are different from the onion epidermal cells. [1]

\_\_\_\_\_  
\_\_\_\_\_

(c) Both figures 1.1 and 1.2 shows tissues. Define the term "tissue". [1]

\_\_\_\_\_  
\_\_\_\_\_

[Total : 4 marks]

2. The diagram below shows a food web.

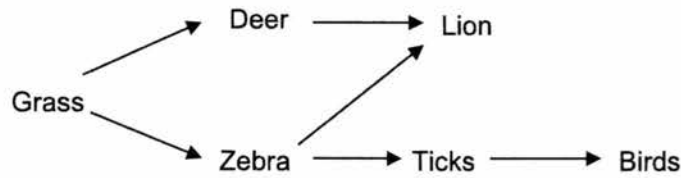

(a) Name the primary consumers in this food web. [1]

---

(b) What is the source of energy for this food web? [1]

---

(c) Suggest, with reasons, what will happen to the zebra population if there is a sudden drought in the habitat. [2]

---

---

---

---

[Total : 4 marks]

3. The diagram below shows a classification chart.

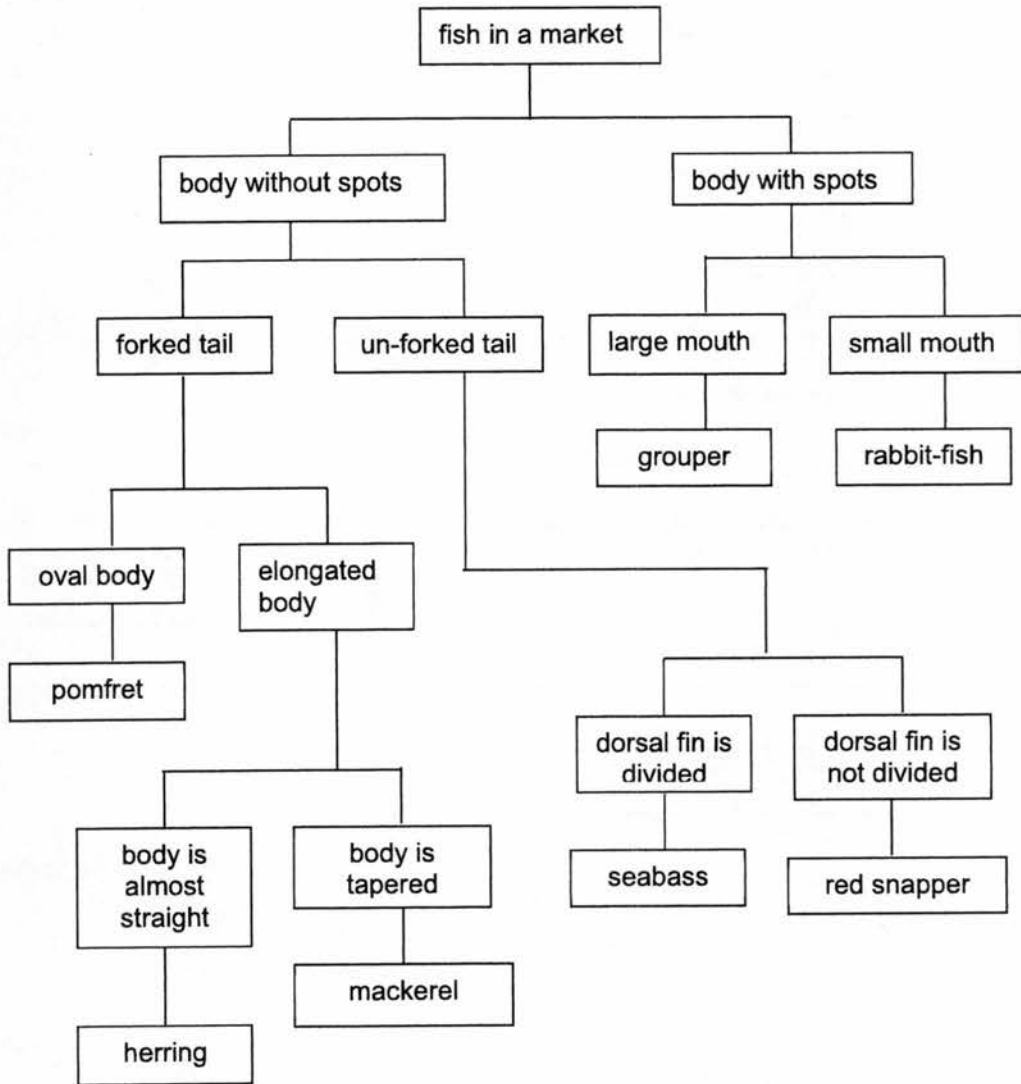

(a) Using the information from the classification chart only, identify two characteristics of a pomfret. [1]

---



---

(b) Identify a feature that can differentiate between a grouper and a mackerel. [1]

---



---

- (c) Is the classification chart shown above considered as a dichotomous key? [1]  
 Explain your answer.

[Total : 3 marks]

4. Fig.4 below shows a section through a part of the stem of a flowering plant.

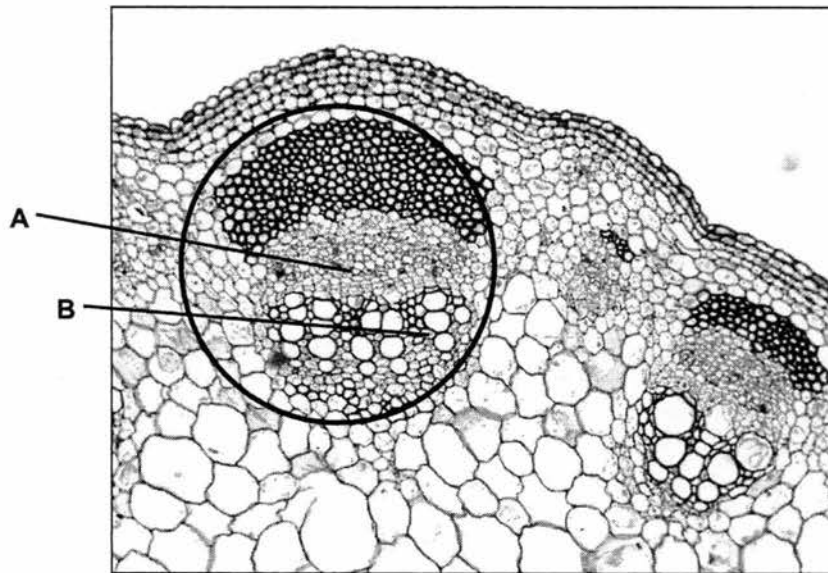

Fig. 4

- (a) Name the structures labeled A and B. [2]

A \_\_\_\_\_

B \_\_\_\_\_

- (b) State the function of each type of cell. [2]

A \_\_\_\_\_

\_\_\_\_\_

B \_\_\_\_\_

\_\_\_\_\_

**Section B: Structured Questions (20 marks)**

5. Fig. 5 shows some red blood cells, as seen through a microscope.

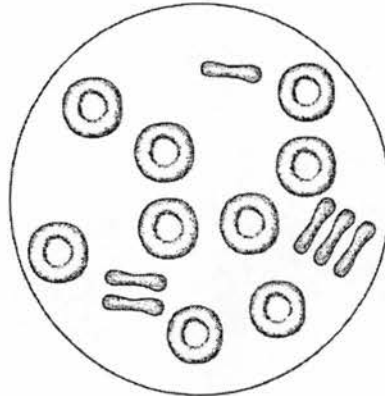

**Fig. 5**

- (a) Name one structure, normally present in cells, that is not present in red blood cells. [1]
- \_\_\_\_\_
- (b) State the main function of the red blood cells. [1]
- \_\_\_\_\_
- \_\_\_\_\_
- (c) Name **one** substance that is carried in the blood by the plasma. [1]
- \_\_\_\_\_
- (d) Complete the table below to identify the components of blood that performs the function stated. [2]

components of blood	function
	helps the blood to clot
	protects the body against infection

[Total : 5 marks]

6. **Fig. 6** shows the cross-sections of three different types of blood vessels **P**, **Q** and **R**.

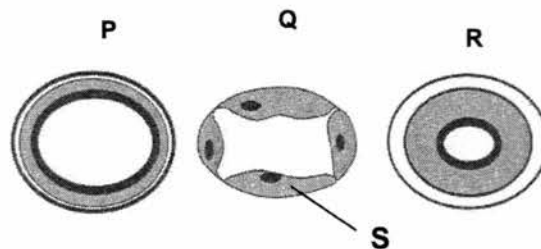

**Fig. 6**

- (a)(i) In which blood vessel **P**, **Q** or **R**, is the blood flow the fastest and at a high pressure? [1]

---

- (ii) Explain how the structure of this blood vessel helps it to withstand the high pressure. [1]

---



---

- (b)(i) Which blood vessel **P**, **Q** or **R**, has valves along it? [1]

---

- (ii) State the important function of the valves mentioned in part (b)(i) above. [1]

---



---

- (c) Explain how the structure of **S** helps the blood vessel **Q** to perform its function. [2]

---



---



---

[Total :6 marks]

7. **Fig. 7** shows a potted plant that was kept in the dark for 48 hours. One of its leaves was then placed in a bottle containing some sodium hydroxide as shown.

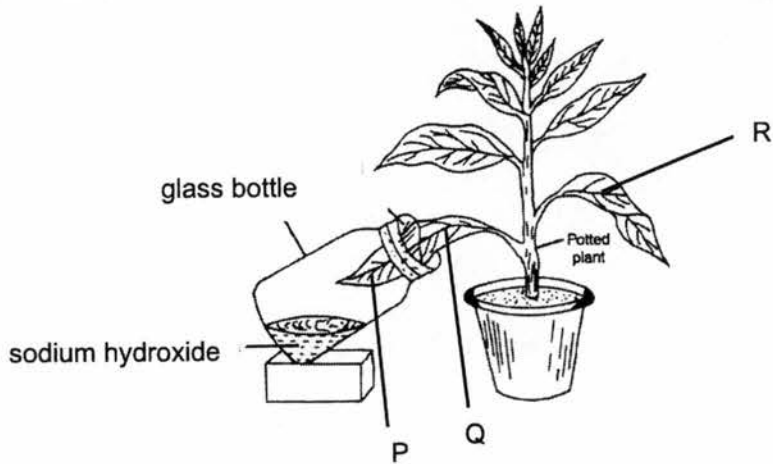

**Fig. 7**

- (a) Write the word equation for photosynthesis. [1]

---

- (b) The plant was then left in bright sunlight for 10 hours. The leaves were then removed and tested for the presence of starch

Complete the table below to predict the results of the starch test for each of the indicated areas and for each part state whether starch is present or absent. [3]

Part of leaf	Results of starch test	Starch present / absent
P		
Q		
R		

- (c) What conclusion can be made from this experiment? [1]

---



---

[Total :5 marks]

8. An experiment was set-up as shown in Fig 8 to investigate what gas is released by green plants in darkness. The set-up was left in a dark room for 8 hours. Limewater turns milky in the presence of carbon dioxide gas.

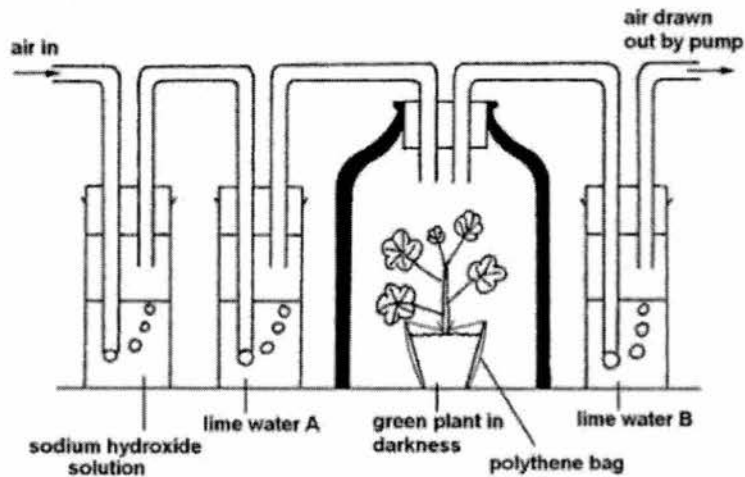

Fig. 8

- (a) At the end of the experiment limewater A remains clear but limewater B turns milky. Suggest a reason why this was observed for each solution. [2]

Limewater A \_\_\_\_\_

\_\_\_\_\_

Limewater B \_\_\_\_\_

\_\_\_\_\_

- (b) Name the process that has occurred in the plant that has brought about the results observed in limewater B. [1]

\_\_\_\_\_

- (c) Name the sugar that is required for this process to take place. [1]

\_\_\_\_\_

End of Paper 3

Paper 1 (15 mcq)

16	C	21	C	26	D
17	A	22	B	27	B
18	B	23	A	28	B
19	A	24	A	29	C
20	B	25	D	30	C

Paper 3

Section A (15 marks)

1(a)	P – cell membrane Q – nucleus R – cytoplasm  3 correct 2m 2 correct 1m 0 / 1 correct – no mark	2m
(b)	Onion epidermal cells have a cell wall but the muscle cells do not have cell walls.	1 m
(c)	A tissue is made up of many cells of the same type performing the same function.	1m
2(a)	Deer zebra	1m Both correct
(b)	sunlight	1m
(c)	-zebra population will decrease -grass will dry up and may not grow well. Thus, the zebra will not have enough food. Some will die due to lack of food	1m 1m
3(a)	Oval body Forked tail Body without spots	1m Any 2 correct
(b)	Body of grouper has spots but body of mackerel has no spots	1m
(c)	Yes It branches into 2 at each point and ends with the identification	1m
4(a)	A – phloem B - xylem	1m 1m
(b)	A – transports manufactured food / sucrose from the leaves to the other parts of the plant B – transports water from the roots to the leaves and other parts of the plant	1m 1m

5(a)	nucleus	1m												
(b)	It transports oxygen from the lungs to the other parts of the body	1m												
(c)	Glucose / amino acids / fats / fatty acids / urea / any relevant	1m												
(d)	- platelets - white blood cells	1m 1m												
6(a)(i)	R	1m												
(ii)	The blood vessel has thick muscular wall to withstand the high pressure of blood flowing through	1m												
(b)(i)	P	1m												
(ii)	Prevents backflow of blood / ensures that blood flows in one direction	1m												
(c)	The wall of the capillary is made up of only a <u>single layer of cells</u> allowing exchange of substances to occur through it / <u>allows substances to pass between the blood and the cells easily</u>	1m												
7	<p style="text-align: center;">sunlight</p> <p style="text-align: center;"> <math>\xrightarrow[\text{chlorophyll}]{\text{carbon dioxide + water}}</math> </p> <p style="text-align: center;">glucose + oxygen</p>													
(b)	<table border="1" style="width: 100%; border-collapse: collapse;"> <thead> <tr> <th style="width: 25%;">Part of leaf</th> <th style="width: 30%;">Results of starch test</th> <th style="width: 25%;">Starch present / absent</th> </tr> </thead> <tbody> <tr> <td style="text-align: center;">P</td> <td style="text-align: center;">Iodine remains brown</td> <td style="text-align: center;">Starch is absent</td> </tr> <tr> <td style="text-align: center;">Q</td> <td style="text-align: center;">Iodine turns blue black</td> <td style="text-align: center;">Starch is present</td> </tr> <tr> <td style="text-align: center;">R</td> <td style="text-align: center;">Iodine turns blue black</td> <td style="text-align: center;">Starch is present</td> </tr> </tbody> </table>	Part of leaf	Results of starch test	Starch present / absent	P	Iodine remains brown	Starch is absent	Q	Iodine turns blue black	Starch is present	R	Iodine turns blue black	Starch is present	3 m - 2 correct 1m
Part of leaf	Results of starch test	Starch present / absent												
P	Iodine remains brown	Starch is absent												
Q	Iodine turns blue black	Starch is present												
R	Iodine turns blue black	Starch is present												
(c)	Carbon dioxide is required for photosynthesis to take place.	1m												
8(a)	A - Sodium hydroxide solution absorbs carbon dioxide from the air in the set up B - carbon dioxide is produced by the plant during the experiment	1m 1m												
(b)	Respiration	1m												
(c)	glucose	1m												



PASIR RIS CREST SECONDARY SCHOOL  
End of Year Examination  
Secondary One Express

CANDIDATE  
NAME

CLASS

	/	
--	---	--

INDEX  
NUMBER

--	--

## SCIENCE (PHY/BIO)

Paper 1 Multiple Choice

9 Oct 2017

Paper 1, Paper 2 and Paper 3 : 2 hours

Additional Materials: Multiple Choice Answer Sheet

### READ THESE INSTRUCTIONS FIRST

Write in soft pencil.

Do not use staples, paper clips, highlighters, glue or correction fluid.

Write your name, class and register number on the answer sheet in the spaces provided.

There are **thirty** questions on this paper. Answer **all** questions. For each question there are four possible answers **A, B, C** and **D**.

Choose the one you consider correct and record your choice in **soft pencil** on the separate answer sheet.

**Read the instructions on the answer sheet very carefully.**

Answers to Paper 1, Paper 2 and Paper 3 must be handed in separately.

Each correct answer will score one mark. A mark will not be deducted for a wrong answer.

Any rough working should be done in this booklet.

For Examiner's Use

30

Parent's Signature

- Which of the following is **not** a S.I. unit?
  - Kilometre
  - Kilogram
  - Ampere
  - Kelvin
- Which of the following has the greatest mass?
  - 1 kg
  - 1000 ng
  - 10 000 mg
  - 10 000 g
- Which of the following lists basic physical quantities only?
  - electric current, time, speed
  - temperature, density, time
  - temperature, mass, amount of substance
  - length, volume, mass
- A student has a can of oil.

Which quantity can be measured using only a measuring cylinder?

- density of oil
  - mass of the oil
  - volume of the oil
  - weight of the oil
- The fuel consumption of a lorry is 12 km/l. How much fuel is needed for the lorry to travel 600 km?
    - 0.02 l
    - 12 l
    - 50 l
    - 7 200 l
  - The diagram below shows the volume of a liquid in a measuring cylinder.

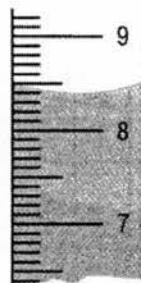

What is the volume of water shown?

- 8.4 cm<sup>3</sup>
  - 8.5 cm<sup>3</sup>
  - 8.8 cm<sup>3</sup>
  - 8.9 cm<sup>3</sup>
- Which of the following best explains the parallax error when measuring an object?
    - It is an error due to the gap between the measuring instrument and the object.
    - It is an error due to the position of the observer's eyes when reading the measurement off a measuring instrument.
    - It is an error due to the mishandling of the instrument by the users when measuring an object.
    - It is an error due to damage to the end of the measuring instrument.

8. A measuring cylinder collects  $160 \text{ cm}^3$  of water in two minutes from a tap. What is the rate of flow of water from the tap?
- A  $0.0125 \text{ cm}^3/\text{s}$       B  $1.3 \text{ cm}^3/\text{s}$       C  $80 \text{ cm}^3/\text{s}$       D  $19\,200 \text{ cm}^3/\text{s}$
9. Jane receives a manuscript which contains 5040 characters. If her rate of typing is 28 characters/s, what is the time taken for her to finish typing the whole manuscript?
- A 180 min      B 80 s      C 0.50 hour      D 3.0 minutes
10. A cook wants to have some food to be cooked by 1.15 p.m. He uses an oven with an automatic timer that can be set to switch on and off at certain times. The oven needs to be switched on for 2 hours 10 minutes.
- At which time does the oven need to switch on?
- A 11.05 a.m.      B 11.25 a.m.      C 3.05 p.m.      D 3.25 p.m.
11. A student is trying to find the density of a stone, but he has mixed up the instruction cards.

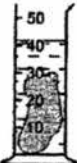
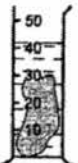
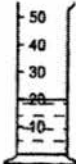
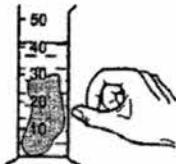
 Find the mass of the stone using a mass balance	 Read the new level of the liquid in the measuring cylinder	 Put the stone into the liquid	Divide the mass of the stone by its volume to find the density
Card 1	Card 2	Card 3	Card 4
 Put some liquid into a measuring cylinder and read the level of the liquid	 Flick the cylinder to get rid of any air bubbles	Subtract the original volume of liquid from the volume of liquid plus the stone	
Card 5	Card 6	Card 7	

What order should the cards be in?

- A  $5 \rightarrow 3 \rightarrow 6 \rightarrow 2 \rightarrow 1 \rightarrow 4 \rightarrow 7$   
 B  $1 \rightarrow 5 \rightarrow 3 \rightarrow 6 \rightarrow 2 \rightarrow 7 \rightarrow 4$   
 C  $5 \rightarrow 6 \rightarrow 3 \rightarrow 2 \rightarrow 1 \rightarrow 7 \rightarrow 4$   
 D  $1 \rightarrow 4 \rightarrow 5 \rightarrow 3 \rightarrow 6 \rightarrow 2 \rightarrow 7$

12. The density of a disc is  $10 \text{ g/cm}^3$ . The disc is cut into two equal parts.

What is the density of one part of the disc?

- A  $5.0 \text{ g/cm}^3$       B  $10 \text{ g/cm}^3$       C  $15 \text{ g/cm}^3$       D  $20 \text{ g/cm}^3$

13. A force acts on a body.

Which list contains only quantities that can be changed by the force?

- A mass, shape, speed  
 B mass, shape, volume  
 C mass, speed, volume  
 D shape, speed, volume

14. When a body moves across a rough surface, a frictional force is produced.

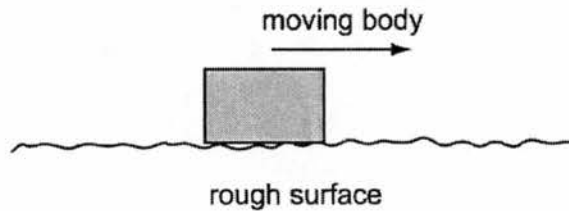

Which statement about this force is **always** true?

- A It acts in the direction of the motion.  
 B It is equal in size to the force producing the motion.  
 C It opposes the motion across the surface.  
 D It makes the body recoil in the opposite direction after stopping it.

15. Diagram 1 shows a piece of foam rubber that contains many pockets of air. Diagram 2 shows the same piece of foam rubber after it has been compressed so that its volume decreases.



diagram 1  
(before compression)

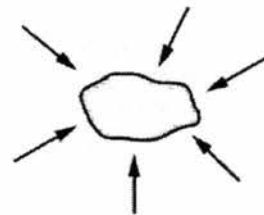

diagram 2  
(after compression)

What happens to the mass and to the weight of the foam rubber when it is compressed?

	mass	weight
A	increases	increases
B	increases	no change
C	no change	increases
D	no change	no change



PASIR RIS CREST SECONDARY SCHOOL  
End of Year Examination  
Secondary One Express

CANDIDATE  
NAME

CLASS

	/	
--	---	--

INDEX  
NUMBER

--	--

## SCIENCE (PHYSICS)

Paper 2 Theory

9 Oct 2017

**Paper 1, Paper 2 and Paper 3: 2 hours**

Candidates answer on the Question Paper.

No Additional Materials are required.

### READ THESE INSTRUCTIONS FIRST

Write your name, class and register number in the spaces above.

Write in dark blue or black pen.

You may use a soft pencil for any diagrams or graphs.

Do not use staples, paper clips, highlighters, glue or correction fluid.

#### Section A

Answer all questions.

#### Section B

Answer all questions.

In calculations, you should show all the steps in your working, giving your answer at each stage.  
Enter the numbers of the Section B questions you have answered on the dotted lines in the grid below.

At the end of the examination hand in your answers to Paper 1, Paper 2 and Paper 3 separately.  
The number of marks is given in the brackets [ ] at the end of each question or part question.

For Examiner's Use	
Section A	
Section B	
TOTAL	
Parent's Signature	



3. A vernier calipers is used to measure the external diameter of a test tube.

With the jaws closed and no test tube, the vernier calipers reading is shown in Fig. 3.1.

With the jaws closed around the test tube, the vernier calipers reading is shown in Fig. 3.2.

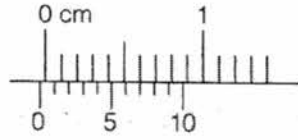

**Fig. 3.1**

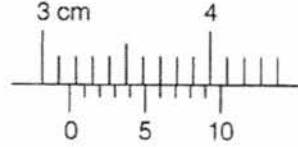

**Fig.3.2**

(a) State the zero error.

zero error = \_\_\_\_\_ [1]

(b) Determine the external diameter of the test tube.

diameter = \_\_\_\_\_ [1]

(c) Explain why it is necessary to take more than one measurement at different positions to obtain an accurate value of the external diameter of the test tube.

\_\_\_\_\_  
 \_\_\_\_\_ [1]

4. Fig. 4.1 shows a parachutist.



Fig. 4.1

- (a) Define *gravitational field strength*.

---

[1]

---

- (b) Draw and label on Fig. 4.1 all forces acting on the parachutist. [2]

- (c) The weight of the parachutist is 800 N on Earth.  
The gravitational field strength on Earth is 10 N/kg and the gravitational field strength on the Moon is 1.6 N/kg.  
Determine the weight of the parachutist on the Moon.

weight = \_\_\_\_\_ [2]

**Section B (20 Marks)**Answer **All** Questions.

5. Fig. 5.1 shows the journey of a car travelling from O to R. Peter drives a car and he takes 9 hours to travel from O to P and 7 hours from Q to R. Peter took a break of 30 minutes and 42 minutes at P and Q respectively.

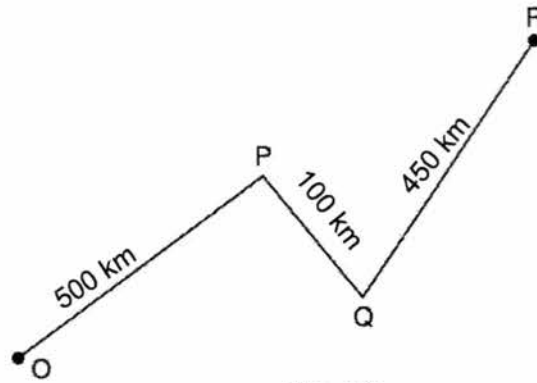
**Fig. 5.1**

- (a) State what is meant by the *average speed*.

---



---

[1]

- (b) Determine the average speed of the car from O to P in km/h.

speed = \_\_\_\_\_ [2]

- (c) The car travel with the same average speed in (b) from P to Q.  
Determine the time taken (in hour) for the car to travel from P to Q.

(d) Determine the total time (in hour) that Peter took a break.

time = \_\_\_\_\_ [1]

(e) Determine the average speed of the car for the whole journey from O to R in km/h.

speed = \_\_\_\_\_ [3]

(f) Convert the average speed of the car in (e) to m/s.

speed = \_\_\_\_\_ [1]

6. A student is investigating volume and density.

The student has a box, as shown in Fig. 6.1 and some dry sand.

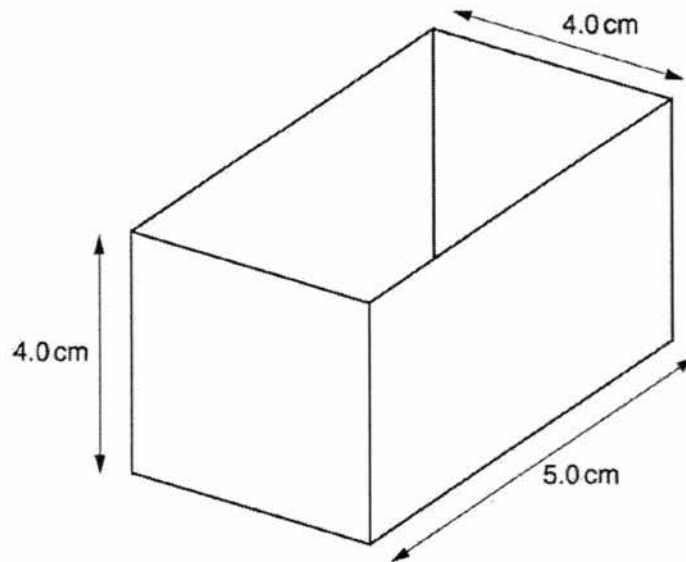

Fig. 6.1

(a) Fig. 6.1 shows the dimensions of the inside of the box.

Calculate the volume of sand needed to fill the box.

volume of sand = \_\_\_\_\_ [1]

(b) The student measures the mass of the box when empty and when filled with sand.

quantity	mass/ g
mass of box filled with sand	180
mass of empty box	20

(i) Define *mass*.

\_\_\_\_\_  
 \_\_\_\_\_ [1]

(ii) State the instrument used to measure the mass.

\_\_\_\_\_  
 \_\_\_\_\_ [1]

(iii) Calculate the mass of the sand in the box.

mass of sand = \_\_\_\_\_ [1]

(iv) Define *density*.

\_\_\_\_\_  
 \_\_\_\_\_ [1]

(v) Calculate the density of the sand in  $\text{g/cm}^3$ .

density of sand = \_\_\_\_\_ [2]

(vi) Convert the density of the sand in (v) to  $\text{kg/m}^3$ .

density of sand = \_\_\_\_\_ [1]

(c) A miner has a bag containing a mixture of silver dust and sand. Silver has a density of  $10.5 \text{ g/cm}^3$ .

He heats the mixture until the silver melts.

Predict what will happen to the sand. Explain your answer using the concept of density.

\_\_\_\_\_  
 \_\_\_\_\_  
 \_\_\_\_\_ [2]

## 1EX EOY Marking Scheme 2017

		Mark	Additional Guide
	<b>MCQ</b>		
1	A		
2	D		
3	C		
4	C		
5	B		
6	A		
7	B		
8	C		
9	D		
10	A		
11	B		
12	B		
13	D		
14	C		
15	D		
	<b>Structured Questions</b>		
	<b>Section A</b>		
1.a.	$420\,000/10^6 = 0.42\text{ Mm}$	A1	
b.	$0.76\ \mu\text{A} = 0.76 \times 10^{-6}$ $0.76 \times 10^{-6}/10^{-9} = 760\ \text{nA}$	C1 A1	
2.a.	Length = $15.6 - 2.4$ Length = $13.2\ \text{cm}$	CA01	No unit - no mark
b.	Wound the piece of cotton around the wooden rod and <b>determine the number of round the cotton goes around the rod</b> (3 round)  Determine the thickness by <b>length of cotton divide by the 3</b>  then <b>divide by 4.</b>  OR <ul style="list-style-type: none"> <li>• Cut/ Fold the cotton into 12 <b>equal</b> parts</li> <li>• Place one part against the rod</li> <li>• The length of the cotton should be the same as the thickness</li> </ul>	B1  B1  B1  B1  B1	Answer must be clear on how the cotton is being used to determine the thickness is 1.1 cm.

## 1EX EOY Marking Scheme 2017

3.a.	-0.03 cm	CA01	
b.	External diameter = $3.16 - (-0.03)$ External diameter = 3.19 cm	B1	
c.	The test tube thickness may be uneven.	A1	No mark for stating that the <u>length</u> might be different at different point
4.a.	gravitational force acting per unit mass on an object OR Weight divided by mass	B1	No mark for writing $\frac{\text{weight}}{\text{mass}}$  or weight <u>over</u> mass
b.	Upward force – air resistance  Downward force – weight/ gravitational force	B1 B'	Minus one mark for every additional mistake. E.g. Upward force – normal reaction force
c.	$W = mg$ $m = w/g$ $m = 800/10 = 80 \text{ kg}$  Weight on moon = 80 (1.6) Weight on moon = $128 = 130 \text{ N}$	B1  B1	
	Section B		
5.a.	<b>Total</b> distance divided by <b>total</b> time (taken)	A1	No mark for Total distance <u>over</u> total time
b.	Average speed = total distance/ total time Average speed = $500/9$ Average speed = $55.5 = 56 \text{ km/h}$	C1 A1	
c.	Average speed = total distance/total time Total time = total distance/average speed Total time = $100/56$ Total time = 1.8 h	C1 A1	Wrong unit for using hrs or hr for hour
d.	Total time = $30/60 + 42/60$ Total time = 1.2 h	A1	Wrong unit for using hrs or hr for hour
e.	Total distance = $500 + 100 + 450 = 1050 \text{ km}$ Total time = $9 + 1.8 + 7 + 1.2 = 19 \text{ h}$ OR $18\frac{69}{70} \text{ h}$  Average speed = $1050/19 = 55.3 = 55 \text{ km/h}$	B1 B1 B1	

## 1EX EOY Marking Scheme 2017

f.	$55 \text{ km/h} = 55(1000)/3600 = 15.3 = 15 \text{ m/s}$	A1	
6a.	$\text{Volume} = 4(4)(5) = 80 \text{ cm}^3$	A1	
b.i.	Amount of matter in a substance/object/body	A1	No mark for Amount of substance in a body
ii.	Mass balance OR Electronic balance OR Beam balance	A1	No mark for Electronic weighing scale Weighing scale
iii.	$\text{Mass} = 200 - 40 = 160 \text{ g}$	A1	
iv.	Mass per unit volume OR Mass divided by volume	A1	No mark for Mass <u>over</u> volume  No mark for writing $\frac{\text{mass}}{\text{volume}}$
V	Density = mass/volume Density = $160/80$ Density = $2.0 \text{ g/cm}^3$	C1 A1	
vi.	$2 \text{ g/cm}^3 = (2/1000)/(1/100 \times 100 \times 100) = 2000 \text{ kg/m}^3$	A1	
c.	The sand will float. sand is less dense than silver	B1 A1	