

Visit

FREETESTPAPER.com

for more papers



Website: [freetestpaper.com](http://www.freetestpaper.com)



[Facebook.com/freetestpaper](https://www.facebook.com/freetestpaper)



[Twitter.com/freetestpaper](https://www.twitter.com/freetestpaper)

Name	Register Number	Class	Calculator Model



MANJUSRI SECONDARY SCHOOL

文 殊 中 學

MID-YEAR EXAMINATION 2018

Subject: Lower Secondary Science
 Paper: Physics and Biology
 Level: Secondary 1 Express
 Date: 10 May 2018
 Duration: 2 hours
 Setter: Dr Mubarak and Ms Muna Ali

Additional Materials: Optical Answer Sheet (OTAS)

READ THESE INSTRUCTIONS FIRST

Write your Name, Register Number and Class in the spaces provided at the top of this page.
 Write in dark blue or black pen.
 You may use a soft pencil for any diagrams, graphs or rough working.
 Do not use staples, paper clips, highlighters, glue or correction fluid.

Section A: Multiple Choice Questions [40 marks]

There are **forty** questions in this section.
 For each question there are four possible answers **A, B, C** and **D**.
 Choose the answer you consider correct and record your choice in soft pencil on the separate Answer Sheet provided.

Section B: Structured Questions [40 marks]

Answer **all** the questions. Write your answers in the spaces provided on the question paper.

Section C: Structured Questions [20 marks]

Answer **all** the questions. Write your answers in the spaces provided on the question paper.

The number of marks is given in brackets [] at the end of each question or part question.

For Examiner's Use		
	Physics	Biology
Section A	20	20
Section B	20	20
Section C	10	10
Subtotal	50	50
Total	100	

Section AAnswer **all** questions.**A1** Which one of the following sets shows only the symbols of SI units?

- A** kg, kg/m³, s, K
- B** g, cm, g/cm³, °C
- C** kg, cm, s, °C
- D** g, km, m/s, °F

A2 A quantity is quoted as having a value of 6.2 ms.

In what units is it measured?

- A** metres
- B** metres per second
- C** microseconds
- D** milliseconds

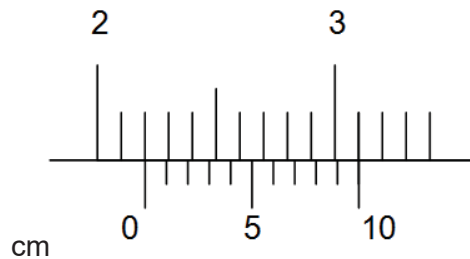
A3 The diagram below shows a vernier scale.

What is the reading shown?

- A** 2.02 cm
- B** 2.10 cm
- C** 2.20 cm
- D** 3.10 cm

- A4** The diagram below shows part of a micrometer screw gauge.

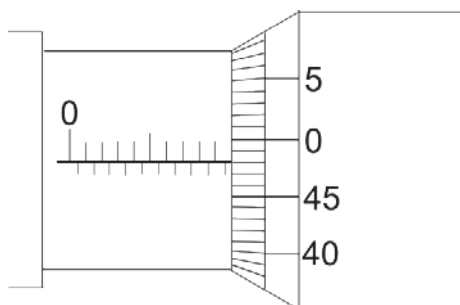

What is the reading shown on the scale?

- A** 9.48 mm **B** 9.98 mm **C** 10.98 mm **D** 19.48 mm
- A5** When designing an experiment to find out the volume of an irregular solid, which of the following apparatus can be used?
- A** displacement can
B displacement can and measuring cylinder
C displacement can and test tube
D round-bottomed flask
- A6** The diagram below shows a measuring cylinder containing water. From which position will the most accurate reading of the volume of the water be made?

- A** position 1
B position 2
C position 3
D position 4

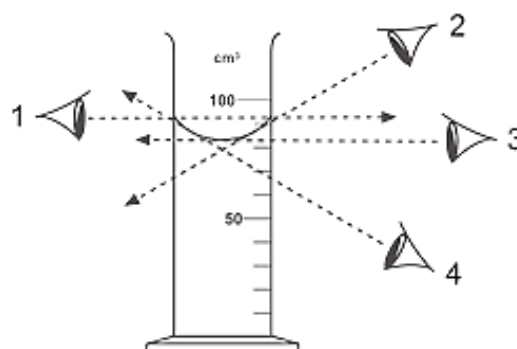

- A7** A pupil has to find the volume of a cork by using a measuring cylinder. The cork floats, so he uses a stone to keep it under the water. He then measures the volume of the stone. The results for each stage of the experiment are shown.

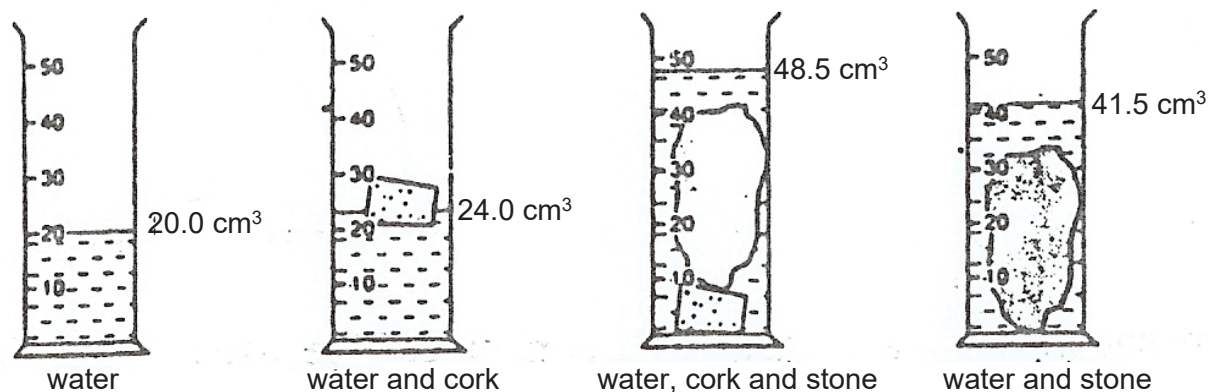

What is the volume of the cork?

- A** 4.0 cm³ **B** 5.0 cm³ **C** 7.0 cm³ **D** 8.0 cm³
- A8** A measuring cylinder containing some water stands on a scale pan. A solid ball is lowered into the water.

The water level rises from the 30 cm³ mark to the 40 cm³ mark.

The scale reading increases from 100 g to 180 g.

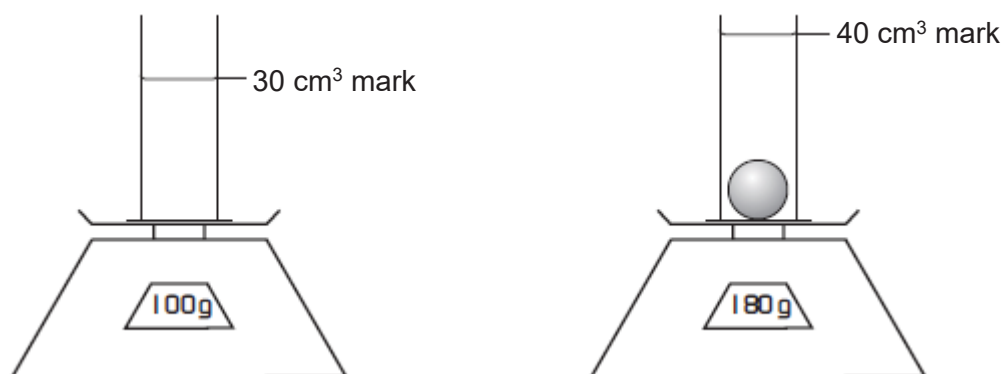

What is the density of the material of the ball?

- A** 0.125 g/cm³ **B** 4.5 g/cm³ **C** 8.0 g/cm³ **D** 18 g/cm³
- A9** Which statement correctly describes the mass of an object?

- A** The pull of gravity on the object.
- B** The material from which the object is made.
- C** The amount of space taken up by the object.
- D** The amount of substance the object contains.

A10 When force is applied to a body, several effects are possible.

Which of the following effects could not occur?

- A** The body rotates.
- B** The body speeds up.
- C** The mass of the body decreases.
- D** The pressure on the body increases.

A11 A brick is placed on a spring balance **X** and then on a beam balance **Y**.

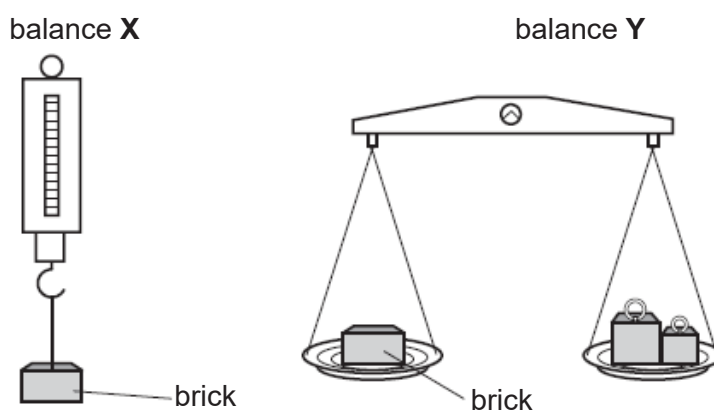

What is measured by each balance?

	balance X	balance Y
A	weight	mass
B	weight	weight
C	mass	mass
D	mass	weight

A12 Jane, a school librarian, finds it easier to use a trolley to move boxes of books around the library.

Which force is reduced due to the usage of the trolley?

- A** contact force
- B** frictional force
- C** gravitational force
- D** magnetic force

A13 The diagram below shows four forces acting on a block.

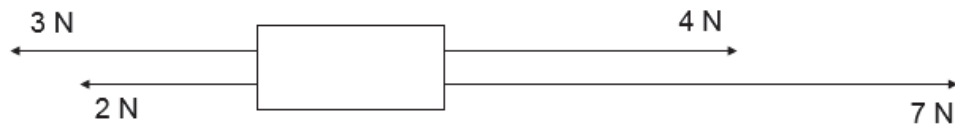

What is the resultant force?

- A** 0 N
- B** 5 N to the left
- C** 6 N to the right
- D** 11 N to the right

A14 The diagram shows a glass block resting on a table top.

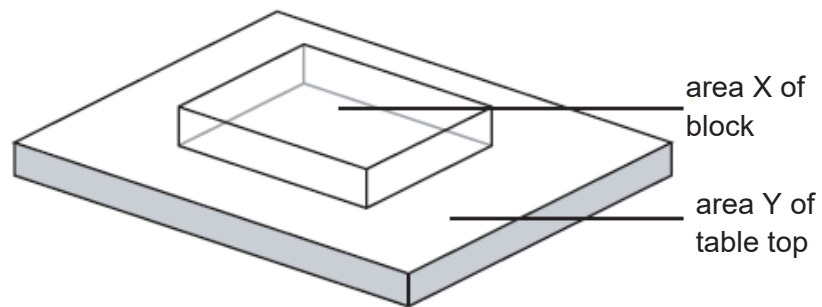

The area of the block in contact with the table is X and the area of the table top is Y.

The weight of the block is P and the weight of the table is Q.

Which expression gives the pressure exerted on the table by the block?

- A** $\frac{P}{X}$
- B** $\frac{P}{Y}$
- C** $\frac{Q}{X}$
- D** $\frac{Q}{Y}$

A15 Objects with different weights are placed on a rigid, horizontal surface.

Which row shows the correct pressure acting on the surface?

	weight / N	area in contact / m ²	pressure / N/m ²
A	10	0.1	1
B	20	0.2	0.01
C	30	0.1	300
D	40	0.2	8

- A16** A curved arrow was cut from a uniformly thick piece of cardboard as shown in the diagram.
Which letter is at the centre of gravity of the piece of cardboard?

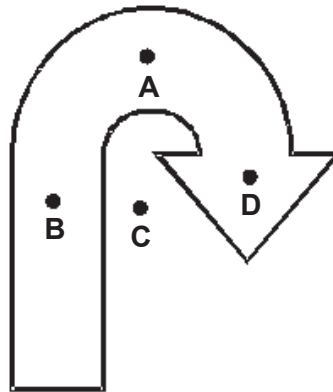

- A17** Which diagram shows an application of the turning effect of a force?



A



B



C

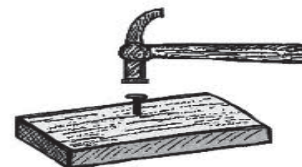

D

- A18** If a nut and bolt are difficult to undo, it may be easier to turn the nut by using a longer spanner.

This is because the longer spanner gives

- A** a larger turning moment.
- B** a smaller turning moment.
- C** less friction.
- D** more friction.

- A19** A uniform beam is balanced at its midpoint. An object is placed on the beam, as shown.

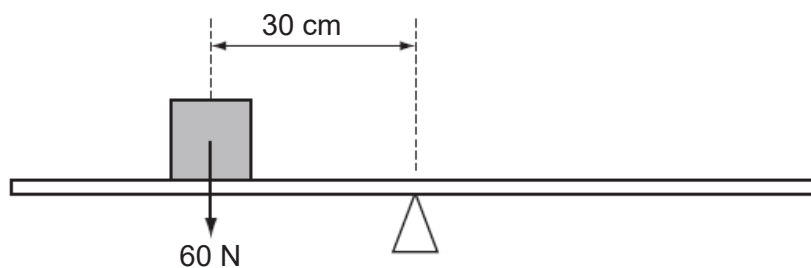

Which force will rebalance the beam?

- A** 30 N acting upwards, 60 cm to the left of the midpoint
B 30 N acting upwards, 60 cm to the right of the midpoint
C 45 N acting downwards, 45 cm to the right of the midpoint
D 90 N acting downwards, 20 cm to the left of the midpoint
- A20** The diagram shows a wheelbarrow and its load, which have a total weight of 150 N. This is supported by a vertical force F at the ends of the handles.

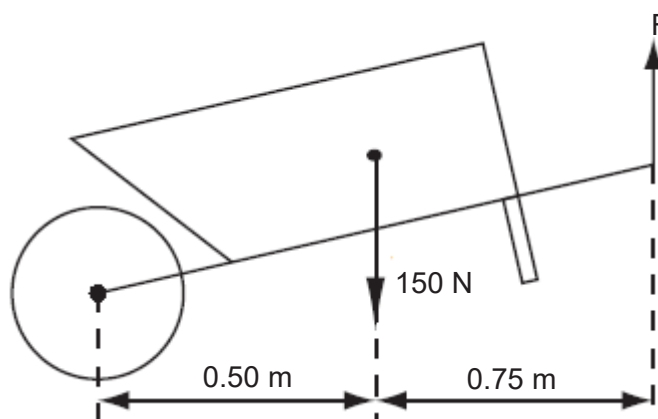

What is the value of F ?

- A** 60 N **B** 75 N **C** 100 N **D** 150 N

A21 Which of the following cells is responsible for transmitting electrical signals around the body?

A



B

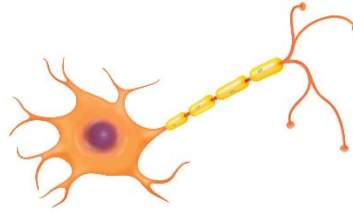

C

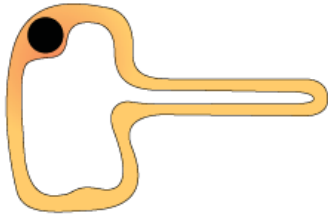

D



A22 Which of the following is **true** about the nucleus?

- I It controls the repair of cells.
- II It regulates cell reproduction.
- III It contains genetic material for cellular reproduction.
- IV It controls the movement of substances in and out of cells.

- A** I and III
- B** I, II and III
- C** II, III and IV
- D** All of the above

A23 Michelle notices that there is an additional outer layer of surrounding each plant cell observed under a light microscope. This additional layer is not present in animal cells. What is the main function of this additional layer?

- A** To provide support for the cells.
- B** To convert light energy into plant food.
- C** To provide an environment for chemical reactions to occur.
- D** To control the movement of substances in and out of the cells.

A24 Below are the descriptions of a specialised cell.
Which of the following describe xylem?

- I It is a living cell.
- II It transports sugars.
- III It has a hollow tube.
- IV It has lignified walls.

- A** I and II only
- B** I and III only
- C** II and III only
- D** III and IV only

A25 A drop of red dye is put into a beaker of water and left for two hours. After two hours, the red dye has spread throughout the solution.

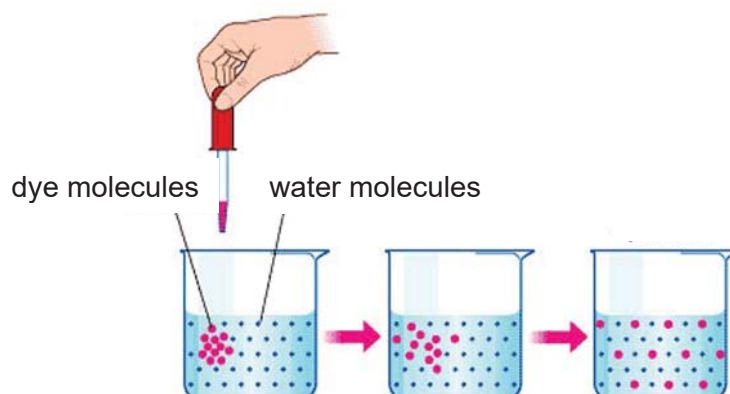

Which of the following best describes this observation?

- A** The red dye molecules move from a region of higher concentration to a region of lower concentration down the concentration gradient.
- B** The red dye molecules move from a region of lower concentration to a region of higher concentration down the concentration gradient.
- C** The red dye molecules move from a region of higher concentration to a region of lower concentration against the concentration gradient.
- D** The red dye molecules move from a region of lower concentration to a region of higher concentration against the concentration gradient.

- A26** Which of the following is an example of osmosis?
- A** The breakdown of food substances into simpler substances by enzymes.
 - B** The absorption of water from the intestinal tract from intestines into the blood vessels.
 - C** The movement of simple food particles from the intestinal tract into the blood vessels.
 - D** The exchange of useful and waste substances across the partially permeable intestinal lining.

- A27** Sam filled a Visking tubing with distilled water. He weighed the Visking tubing before and then one hour after placing it in a beaker containing 20% sucrose solution.

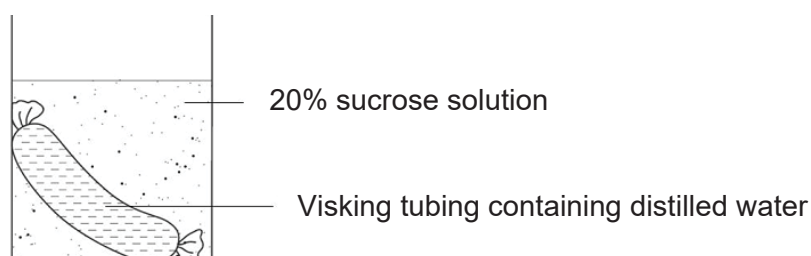

Which of the following will be the expected observation and process responsible after one hour?

	mass of Visking tubing	molecules involved	direction of movement
A	increase	water	into tubing
B	decrease	water	out of tubing
C	increase	sucrose	into tubing
D	decrease	sucrose	out of tubing

A28 The diagram below shows the structure of an air sac in a human lung.

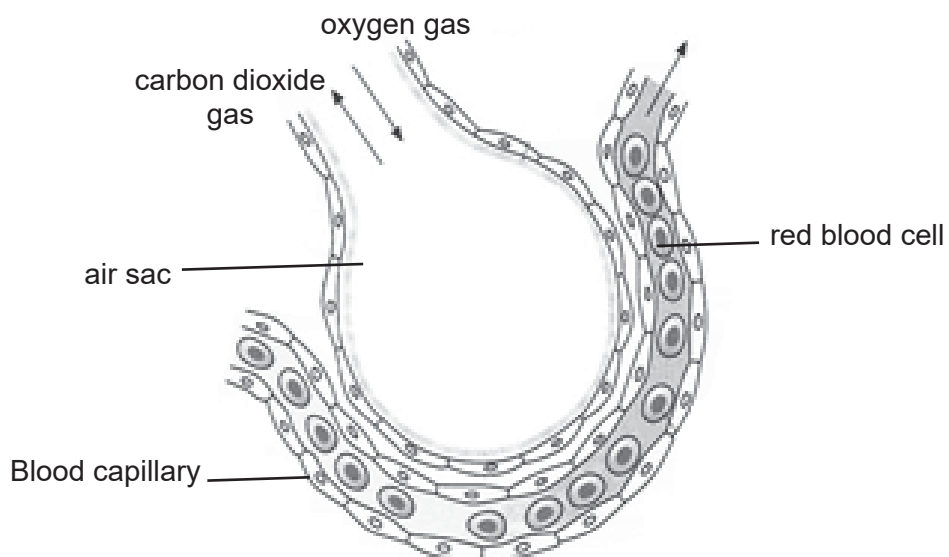

Which of the following will account for the movement of gases across the air sac?

	air sac	blood capillary
A	high in oxygen	high in carbon dioxide
B	high in oxygen	low in carbon dioxide
C	low in oxygen	high in carbon dioxide
D	low in oxygen	low in carbon dioxide

A29 The diagram below shows a root hair cell in soil.

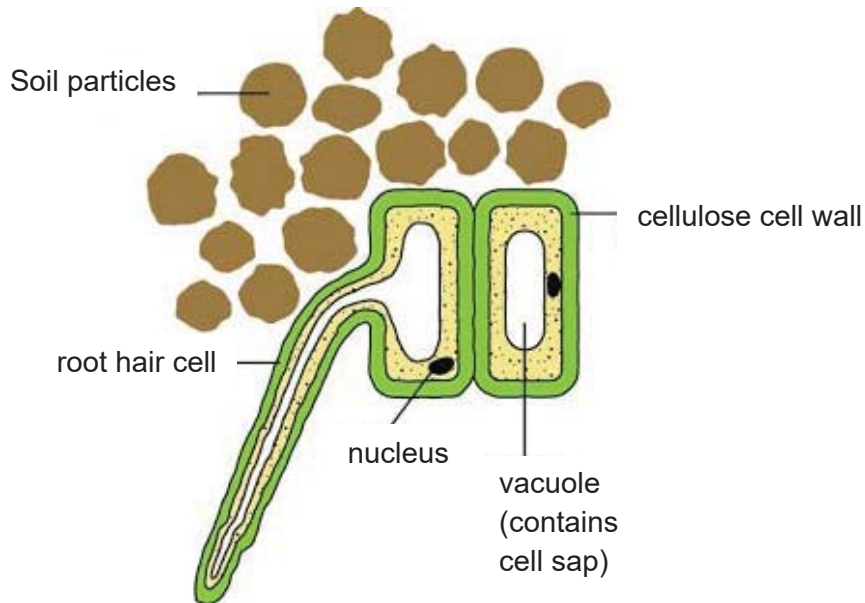

Which of the following will account for the water potential of cell sap compared to the soil and movement of water molecules across the cell to ensure its survival?

	concentration of cell sap compare to the soil	movement of water molecules
A	higher water potential	move into cell via osmosis
B	higher water potential	move out of cell via osmosis
C	lower water potential	move into cell via osmosis
D	lower water potential	move out of cell via osmosis

A30 The diagram below shows a blood sample under a microscope. Which component helps to transport digested food molecules?

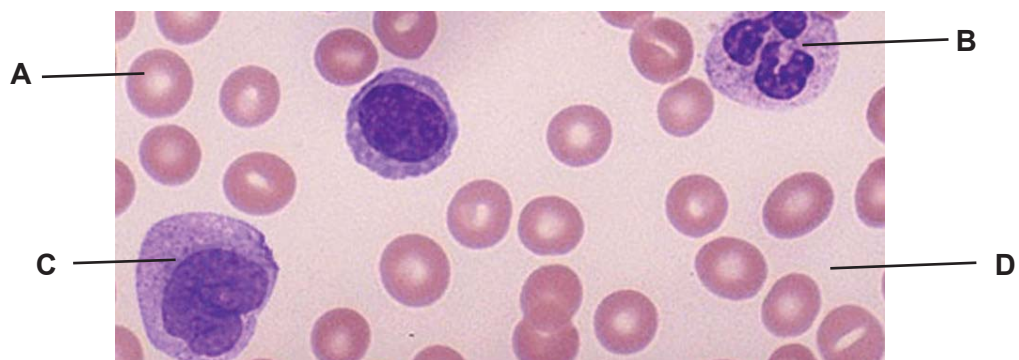

A31 Anaemia is a condition where a person does not have enough functional red blood cells in the body. A person suffering from anaemia may

- A** feel hyperactive.
- B** feel hungry often.
- C** feel dizzy and faint.
- D** have loss of memory.

A32 A red blood cell is biconcave in shape to allow

- A** more space for oxygen to bind.
- B** haemoglobin to occupy the space.
- C** it to squeeze through the small capillaries.
- D** a greater surface area to volume ratio for efficient absorption of oxygen.

A33 Which of the following statements below correctly describe vascular bundles in plants?

- I** They are specialised tissues.
- II** They carry oxygen within the plant.
- III** They carry water, mineral salts and food.
- IV** They can be found throughout the plant in parts such as leaves, stem and roots.

- A** II and IV only
- B** I, II and III only
- C** I, III and IV only
- D** All of the above

A34 The diagrams below show the different parts of the plant.

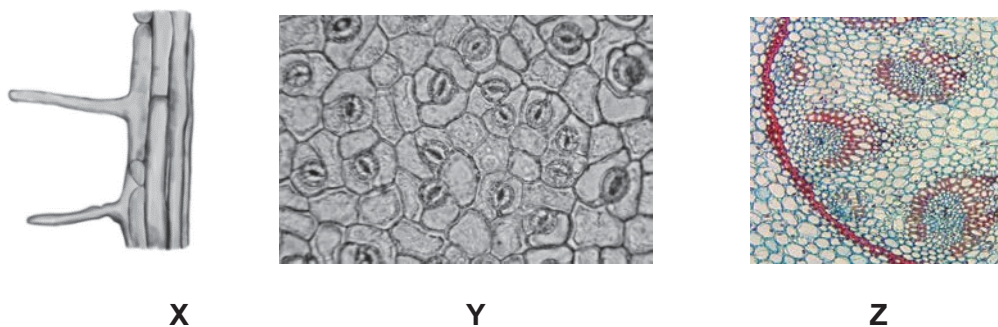

Which of the following correctly identifies the parts of plants shown?

	X	Y	Z
A	root	stem	leaf
B	root	leaf	stem
C	leaf	root	stem
D	leaf	stem	root

A35 What process is responsible for the movement of water in the xylem?

- A** diffusion
- B** osmosis
- C** translocation
- D** transpiration

A36 The diagram below shows a green plant.

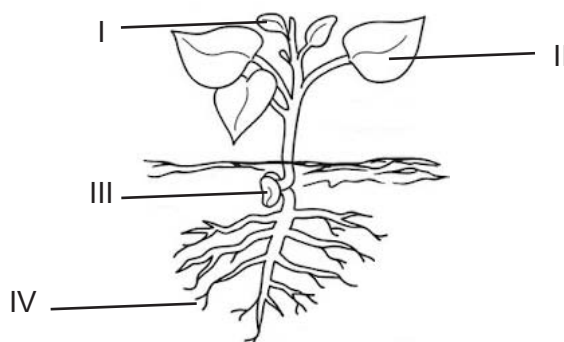

Where will food made by leaf be transported?

- A** I and II only
- B** II and III only
- C** I, II and III only
- D** I, II, III and IV

- A37** Which of the following statements best defines a community?
- A** A group of organisms of the same species that live in an area.
 - B** Many groups of organisms of different species that live in an area.
 - C** Many groups of organisms of different species interacting with each other and the environment in which they all live in.
 - D** The study of the interactions between many groups of organisms of different species and the environment in which they all live in.

- A38** The graph below shows the global carbon dioxide levels from the year 1900 to 2000.

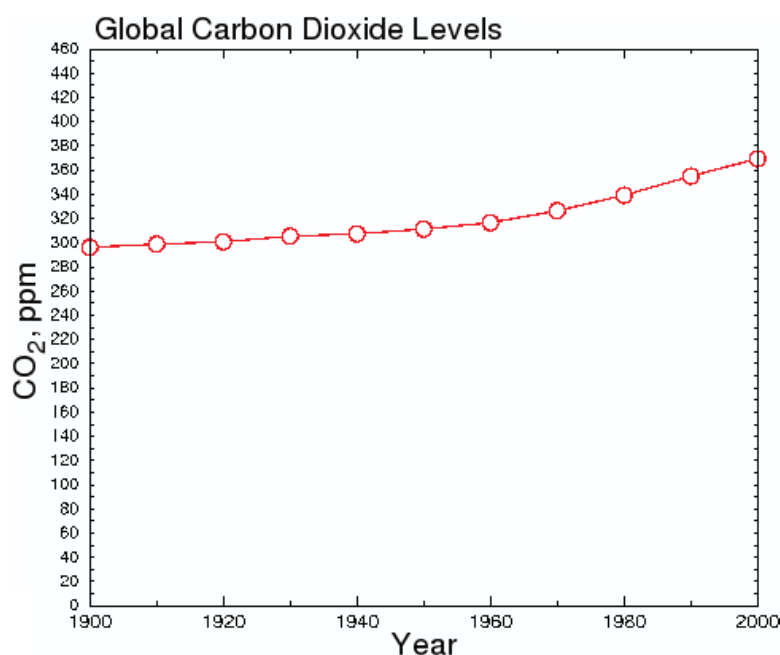

What can be concluded from the graph?

- A** The amount of carbon dioxide has increased slowly from 1900 to 2000.
- B** The amount of carbon dioxide has increased drastically from 1900 to 2000.
- C** The amount of carbon dioxide has increased slowly from 1900 to 1950 and increased drastically to 2000.
- D** The amount of carbon dioxide has increased drastically from 1900 to 1950 and increased slowly to 2000.

A39 Energy is lost in a food web as it is transferred from one organism to another.

Which of the following is **not** a means by which energy is lost?

- A** defecation
- B** excretion
- C** photosynthesis
- D** respiration

A40 A food chain is shown below.

tree → caterpillar → X → eagle

What is organism **X**?

- A** primary producer
- B** primary consumer
- C** secondary consumer
- D** tertiary consumer

END OF SECTION A

Section B

Answer all questions.

- B1** Complete the table by filling in the most suitable instrument that can be used to measure each of these physical quantities and their respective accuracy.

The first line is done for you.

Measurement	Instrument	Accuracy
Exactly 36.3 cm ³ of water	Measuring cylinder	0.1 cm ³
Depth of a paper cup		
Circumference of a tree		
Thickness of copper wire		

[3]

- B2** Convert the following readings to the units indicated. Show your workings clearly.

(a) 0.045 cm = m [1]

(b) 3.04 l = m³ [1]

- B3** Fig. 3 shows a pendulum oscillating between positions X and Z. It takes 1.5 s to go from X to Z and back to the mid-point Y.

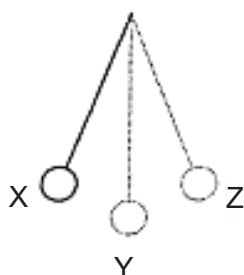
**Fig. 3**

- (a) Determine the period of the pendulum.

period = [1]

(b) State what you can do to ensure that the measurement of the period of the pendulum is as accurate as possible during an experiment.

.....
.....
..... [1]

(c) State **one** thing you can do to increase the period of the oscillation.

..... [1]

B4 (a) Fig. 4.1 shows two different types of excavators of the same mass.



Fig. 4.1

Which excavator is more suitable for operating on soft, muddy ground? Explain your answer using the concept of pressure.

.....
.....
..... [2]

- (b) Fig. 4.2 shows a fork-lift tractor with a mass of 3000 kg transporting a load of 2400 N. The centre of gravity of the tractor is labelled as CG in Fig. 4.2. The engine of the tractor is switched off and the tractor is slowing down to a stop.

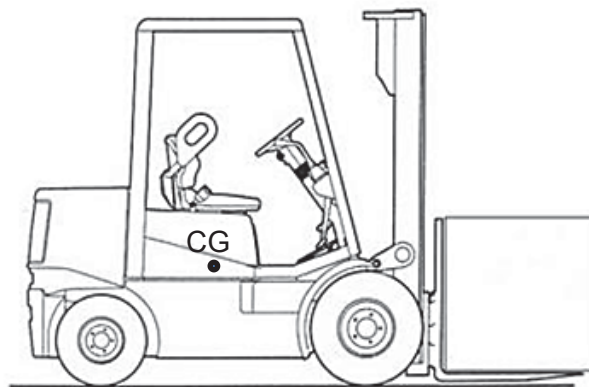

Fig. 4.2

- (i) On Fig. 4.2, using the letters **f**, **W**, **N₁** and **N₂**, draw labelled arrows to show the following:
1. friction between the wheels and the floor, (**f**)
 2. weight of the tractor, (**W**) and
 3. contact force(s) exerted on the tractor by the floor (**N₁** and **N₂**). [3]
- (ii) Calculate the total weight of the tractor and load, given gravitational field strength is 10 N/kg.

total weight = [2]

- (iii) The contact area of **each** wheel is 0.80 m².

Calculate the pressure exerted on the floor by the tractor and load if the tractor has 4 wheels.

pressure = [2]

- B5** Fig. 5 shows a crane lifting some bricks during the building of a house.

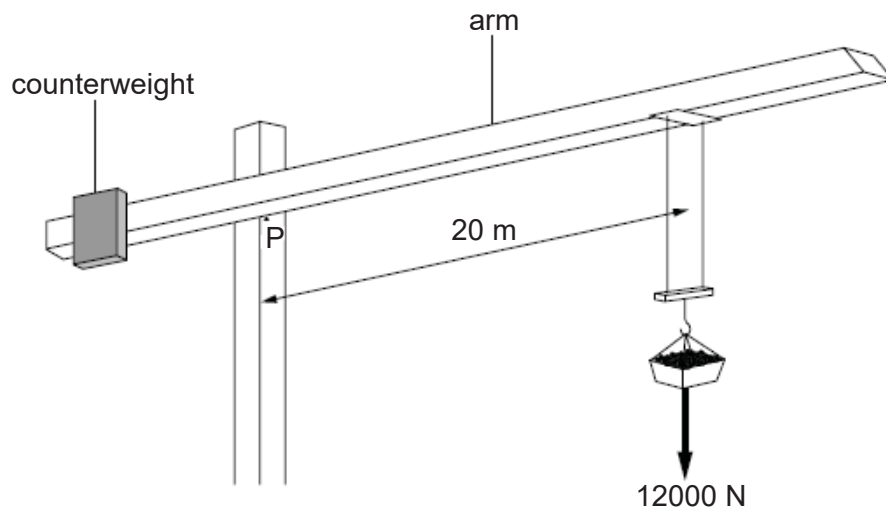

Fig. 5

The weight of the bricks produces a turning effect, or moment, on the arm of the crane about the point P. The weight of the bricks is 12000 N.

- (a) Calculate the moment of this force, using the distance marked on Fig. 5.

moment = [2]

- (b) State the direction of the moment caused by the weight of the counterweight about the pivot P.

..... [1]

B6 Fig.6 below shows the human transport system, which carries blood throughout the body.

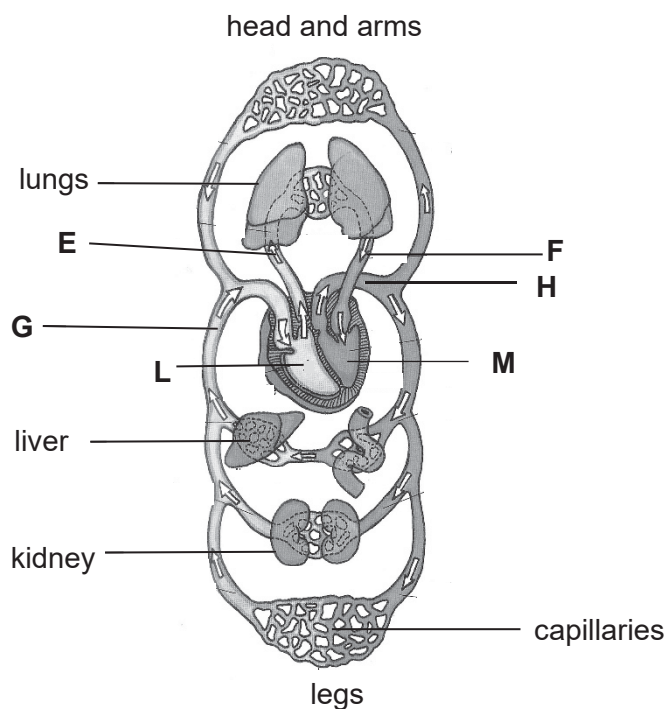

Fig. 6

(a) Name blood vessels **E** to **H**.

- E**
- F**
- G**
- H**

[4]

(b) Which side of the heart, **L** or **M**, contains deoxygenated blood? Explain your answer.

.....

[2]

(c) Explain why capillaries are one-cell thick.

.....

[1]

(d) Give **two** differences between vessels **E** and **F**.

.....

.....

.....

..... [2]

B7 Fig. 7.1 shows a simple food web for an African grassland ecosystem.

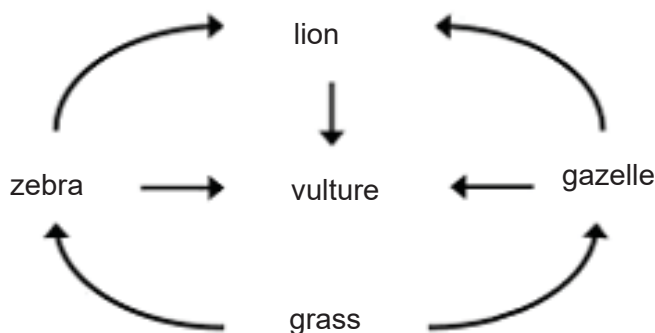

Fig. 7.1

(a) (i) The vultures feed on the carcasses of dead animals for energy.
State the role of the vultures in this ecosystem.

..... [1]

(ii) Suggest how the population of vultures will change over a period of time during a drought (dry season) in the grassland.

.....

.....

.....

..... [2]

- (b) The relationship between grass, zebras and lions in the African grassland is shown in the following Graph 7.2.

Graph of population of grass, zebras and lions against time

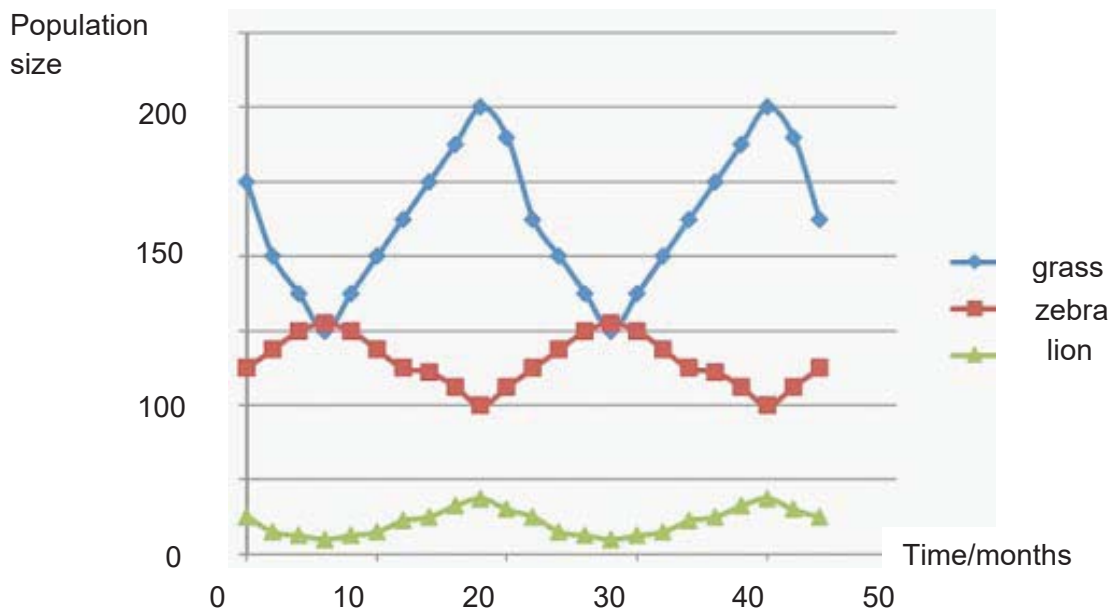

Graph 7.2

- (i) State what will happen to the grass population if the number of zebras increases. Explain your answer clearly.

.....
 [1]

- (ii) Explain why there are more zebras than lions in the African grassland.

.....

 [2]

B8 Fig 8.1 shows a young flowering plant placed in a red dye solution for one day.

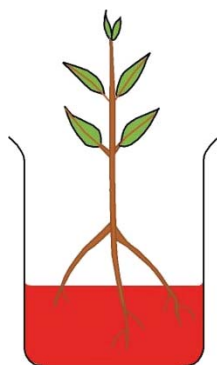

Fig 8.1

Fig 8.2 shows the cross-section of a plant stem under a light microscope.

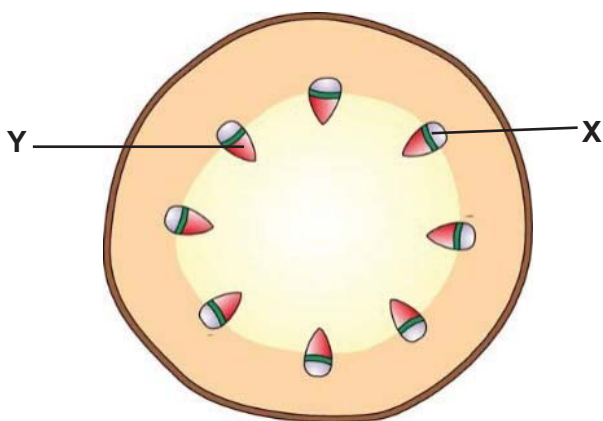

Fig. 8.2

(a) Identify and state the function of regions **X** and **Y**.

(i) region **X**

function

..... [2]

(ii) region **Y**

function

..... [2]

(b) Which region **X** or **Y** will be stained with the red dye? Explain your answer.

.....

..... [1]

END OF SECTION B

Section C

Answer all questions

For
Examiner's
Use

- C1** A measuring cylinder contains 30 cm^3 of liquid. When 600 identical spherical polyvinyl chloride (PVC) pellets are dropped into the liquid, they sink to the bottom and the liquid level rises to 36 cm^3 . The density of a PVC pellet is 1.39 g/cm^3 .

- (a) (i) State the density of 600 pellets.

density = [1]

- (ii) Determine the mass of 600 pellets.

mass = [2]

- (b) Table 9.1 shows the density of three substances.

Substances	Density (g/cm^3)
paraffin oil (liquid)	0.80
carbon tetrachloride (liquid)	1.60
glycerine (liquid)	1.26

Table 9.1

An equal volume of the three liquids in Fig. 9.1 are poured into a beaker, as shown on Fig. 9.2.

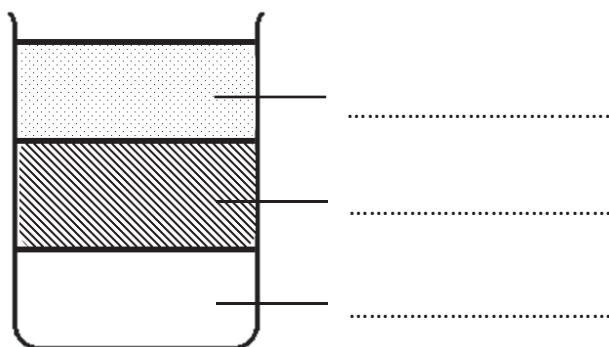

Fig. 9.2

(i) Using the information given in Table 9.1, identify the liquids on Fig. 9.2 by writing their names in the spaces provided in Fig. 9.2. [1]

(ii) In Fig. 9.2, use a cross (X) to indicate where the PVC pallet would be if it is put into the beaker. [1]

(iii) Which liquid from Table 9.1 would you use to find the volume of a piece of PVC pallet using the displacement method with a measuring cylinder? Explain your answer.

.....
.....
..... [2]

(c) The pallet is brought from Earth to Moon. State whether the following quantities will increase, decrease, or remain the same.

Explain the reason for each of your answers.

(i) mass

.....
..... [1]

(ii) weight

.....
..... [1]

(iii) density

.....
..... [1]

- C2** Table 10 shows the results of an experiment carried out using five potato strips of the same length. The strips were placed in tubes containing different concentration of sucrose solutions. The length of each potato strips were measured after 2 hours.

Table 10

Tube	Concentration of sucrose solution (mol/dm ³)	Length of potato at start (mm)	Length of potato after 2 hours (mm)	Change in length (mm)
A	0	40	40.7	
B	0.2	40	39.9	
C	0.4	40	39.2	
D	0.6	40	38.4	
E	0.8	40	37.7	-2.3

- (a) Fill in the table with the correct values. [1]

- (b) Define the process that occurred in the potato strips, causing a change in length.

.....

.....

.....

..... [2]

- (c) Explain why the potato strips in tube **E** decrease in length?

.....

.....

.....

..... [2]

(d) Plot the graph of change in length against concentration of sucrose solution on the graph provided.

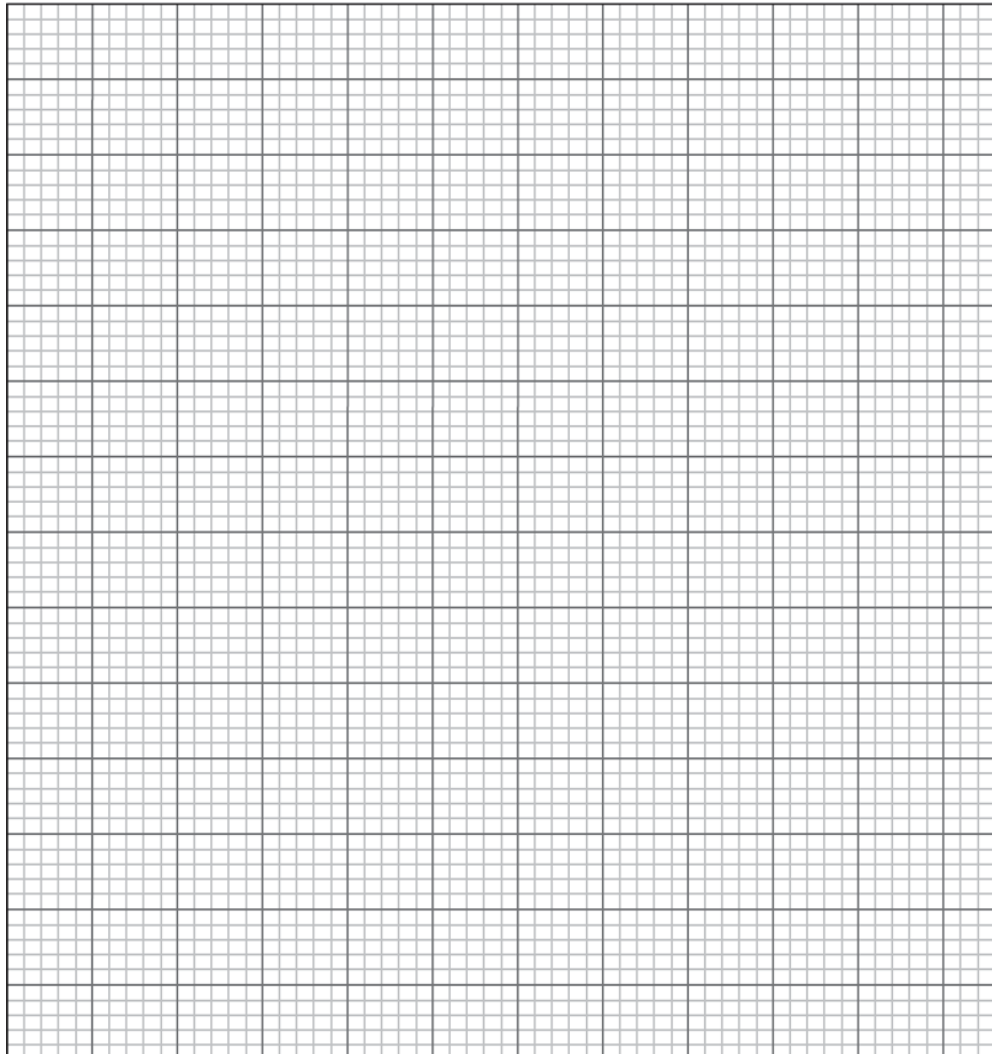

[3]

(e) Based on the graph, state and explain the concentration of the potato cell sap.

.....

.....

.....

.....

[2]

END OF PAPER

BLANK PAGE

*For
Examiner's
Use*

BLANK PAGE

*For
Examiner's
Use*

BLANK PAGE

*For
Examiner's
Use*

