

Visit

FREETESTPAPER.com

for more papers



Website: [freetestpaper.com](http://www.freetestpaper.com)



[Facebook.com/freetestpaper](https://www.facebook.com/freetestpaper)



[Twitter.com/freetestpaper](https://www.twitter.com/freetestpaper)

Section A (30 marks)

Answer **all** questions.

Shade your answers in the OTAS provided.

1. A pair of vernier calipers is used to measure the thickness of a book.

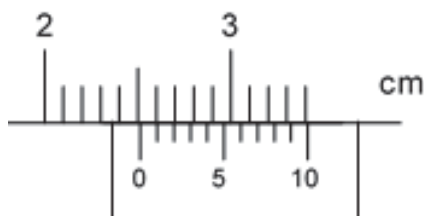

What is the thickness of the book?

- A** 2.03 cm
B 2.31 cm
C 2.51 cm
D 2.62 cm
2. Which instrument below can be used to measure the amount of matter in a substance?
- A** burette
B spring balance
C beam balance
D displacement can
3. The table shows information about four objects.

object	mass/ g	volume/ cm ³
P	30	6
Q	40	5
R	50	10
S	60	4

Which two objects have the same density?

- A** P and Q
B P and R
C Q and S
D R and S
4. A measuring cylinder contains 100 cm³ of water. An irregularly shaped object of mass 50 g is lowered slowly into the cylinder until it is completely immersed in the water.
- Given that the density of the object is 5.0 g/cm³, what is the new reading on the measuring cylinder?
- A** 105 cm³
B 110 cm³
C 150 cm³
D 155 cm³

[Turn over

5. The table shows the properties of four different materials.

Which material is possibly a metal?

	density	electrical conductivity	appearance
A	low	poor	yellow
B	low	good	black
C	high	poor	shiny
D	high	good	shiny

6. A robotic vehicle, which has a weight of 800 N on Earth, was sent to Mars to explore its surface. The gravitational field strength is 4 N/kg on Mars and 10 N/kg on Earth.

What is the robotic vehicle's weight on Mars?

- A** 20 N
B 32 N
C 200 N
D 320 N
7. In which of the following positions will a person exert the greatest pressure on the ground?

- A** The person stands on one foot.
B The person sits cross-legged on the floor.
C The person stands on both feet.
D The person lies flat on his back.

8. An object with a mass of 2.0 kg has 300 J of kinetic energy.

What is the speed of the object?

- A** 8.7 m / s
B 12.8 m / s
C 17.3 m / s
D 24.5 m /s
9. In which of the following cases is there completely no work done?
- A** A car slowing down when approaching a pedestrian crossing.
B A man holding a big shopping bag on an escalator moving upwards.
C A student holding her files standing at the bus stop.
D A delivery man holding a new TV set standing in a lift moving upwards.

10. The total energy of a free falling object is the sum of the gravitational potential energy and kinetic energy.

Assuming that air resistance is negligible, which of the following best represents the changes in the different energies when the object is falling freely under gravity?

	Gravitational potential energy	Kinetic energy	Total energy
A	increases	decreases	remains constant
B	decreases	increases	remains constant
C	decreases	increases	decreases
D	increases	decreases	increases

11. Which of the following physical properties can be used to describe non-metals?

- I They are poor conductors of electricity.
- II They have lower melting and boiling points.
- III They are brittle.

- A I, II
- B II, III
- C I, III
- D I, II, III

12. The diagram below shows the particles found in substance **M**.

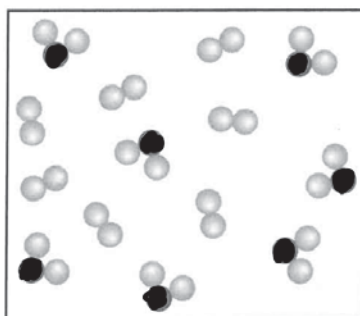

Which of the following statements correctly describes Substance **M**?

- A Substance **M** is a compound.
- B Substance **M** is a mixture of elements.
- C Substance **M** is a mixture of compounds.
- D Substance **M** is a mixture of an element and a compound.

16. A glass of apple juice is a solution while orange juice is considered a suspension.

Which of the following correctly identifies the difference between a suspension and solution?

- A The speed at which the solute dissolves in the solvent.
 B The amount of solute that can dissolve in the solvent.
 C When left to stand, whether particles are suspended in the liquid.
 D Any change in colour.
17. The effect of temperature on the solubility of two substances in the same amount of solvent was investigated. The results are shown in the graph below.

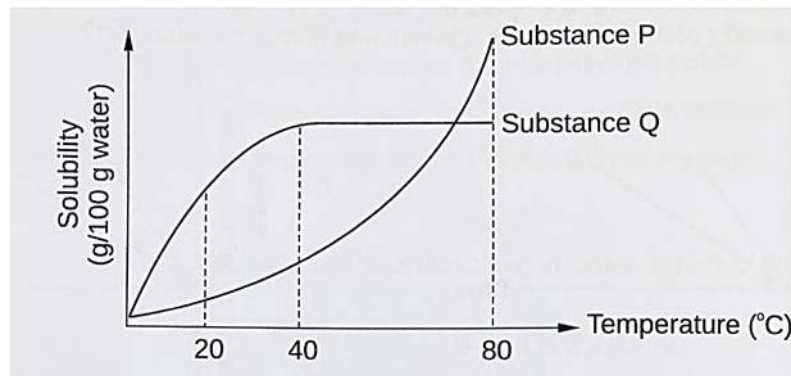

Which of the following statement **cannot** be concluded from the graph?

- A Solubility of substance P continues to increase after 80 °C.
 B Substance Q has reached the maximum solubility after 40 °C.
 C At 20 °C, substance Q dissolves more than substance P.
 D Solubility of substance P increases when temperature increases from 20 °C to 40 °C.
18. The diagram shows a specialized cell from a plant.

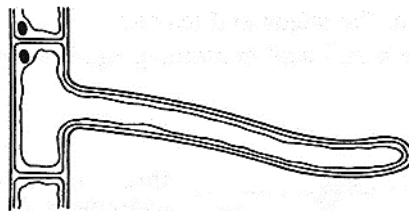

Which function is the cell modified for?

- A absorption of water
 B photosynthesis
 C storage of food
 D support

19. The diagram shows some heart muscle cells.

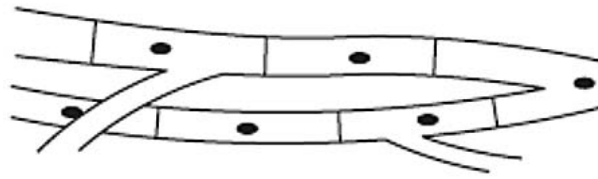

Which describes the level of organisation of the cells and their specific function?

	level of organisation	specific function
A	organ	contraction
B	organ	support
C	tissue	support
D	tissue	contraction

20. An *Amoeba*, a unicellular organism, had its nucleus removed by using a fine glass tube but was otherwise not damaged. For seven days, it continued to move and feed, but it did not reproduce. An intact *Amoeba*, which was used as a control, had reproduced twice in seven days.

What is **another** function of the nucleus that can be concluded from this experiment?

- A The nucleus controls cellular activities.
 B The nucleus controls the movement of the cell.
 C The nucleus is essential for cell reproduction.
 D The nucleus is essential for the uptake of water.
21. The diagram shows a cell observed under a microscope.

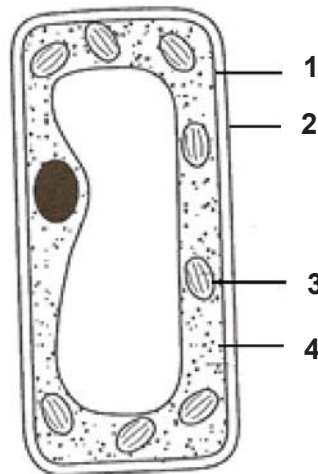

Which are the correct labels for cell organelle 1, 2, 3 and 4?

	cellulose cell wall	cell surface membrane	chloroplast	cytoplasm
A	1	2	3	4
B	1	2	4	3
C	2	1	3	4
D	2	1	4	3

22. Four clear agar blocks **A**, **B**, **C** and **D**, which are of different dimensions, were placed in solutions of methylene blue of the same concentration.

Which agar block will be the **slowest** to be completely stained blue?

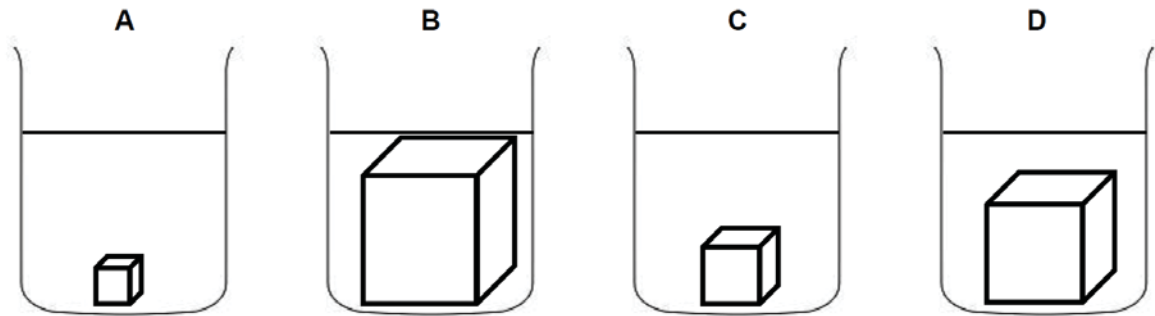

23. The diagram shows an experiment.

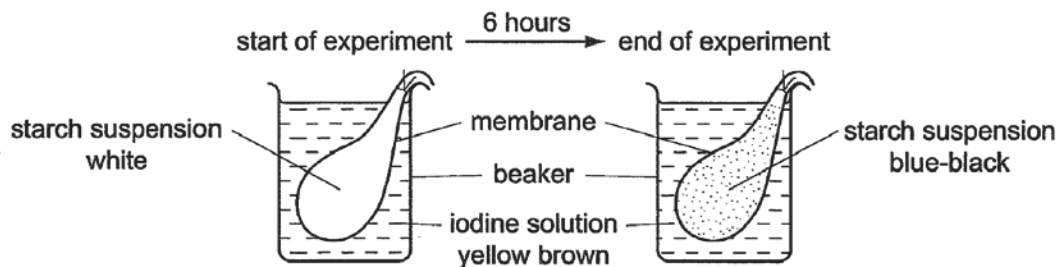

Why has the starch suspension changed colour at the end of the experiment?

- A Iodine has diffused in through the membrane.
 - B Iodine has diffused out through the membrane.
 - C Starch has diffused in through the membrane.
 - D Starch has diffused out through the membrane.
24. Which statements are true?
- I Plasma helps to transport dissolved substances.
 - II Platelets help in the clotting of blood.
 - III White blood cells help to transport oxygen.

- A I and II only
- B I and III only
- C II and III only
- D I, II and III

[Turn over

25. The diagram shows red blood cells.



The red blood cells were placed in solutions **P**, **Q**, **R** and **S** of different solute concentrations. After one minute, the appearance of the cells was as shown below.

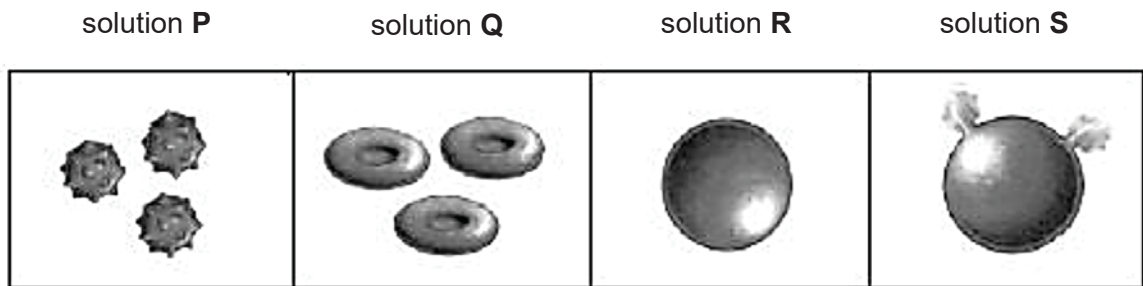

Which conclusion can be drawn from these observations?

- A Solution P has a lower water potential than the cytoplasm of the red blood cell.
- B Solution Q has a higher water potential than the cytoplasm of the red blood cell.
- C Solution R has a lower water potential than the cytoplasm of the red blood cell.
- D Solution S has approximately the same solute concentration as the cytoplasm of the red blood cell.

26. The diagram below shows a simplified model of blood circulation in a mammal.

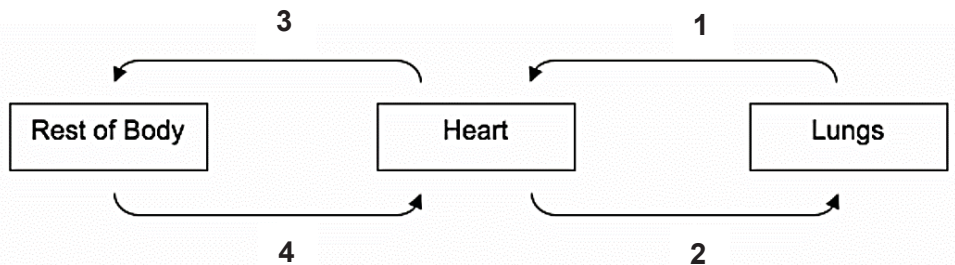

Which of the following correctly shows the identity of blood vessels **1**, **2**, **3** and **4**?

	artery	vein
A	1 and 2	3 and 4
B	1 and 3	2 and 4
C	1 and 4	2 and 3
D	2 and 3	1 and 4

27. The diagram shows a section through a stem.

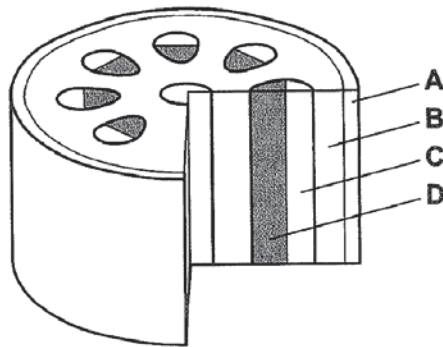

Which labelled tissue transports water and mineral salts towards the leaves?

28. Which of the following secretions contains enzymes that are able to break down carbohydrates, proteins and fats?
- A bile
 B saliva
 C gastric juice
 D pancreatic juice
29. The table below shows the composition of four foods in grams per 100 g portion.

Which food would be most useful for providing an immediate source of energy?

food	carbohydrate/g	fat/g	protein/g
A	60.2	0.0	0.5
B	8.6	35.0	32.1
C	0.0	0.0	45.0
D	14.8	10.8	0.3

30. The diagram below shows a section of the human digestive system.

In which structure does the absorption of most food molecules occur?

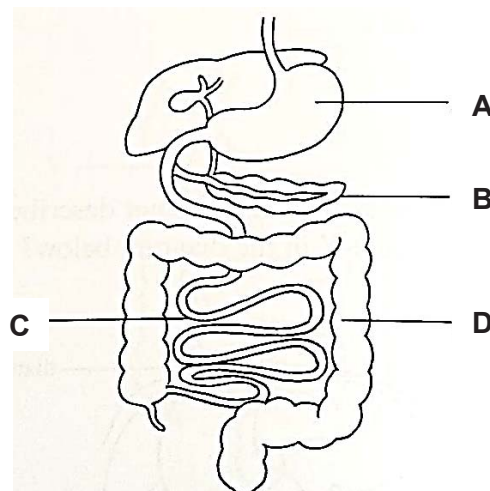

-End of Section A-

[Turn over

Section B (40 marks)

For
Examiner's
Use

Answer **all** questions in the spaces provided.

- B1** Civil engineers help to build structures such as bridges. Fig. 1.1 shows a bridge supported by 4 pillars. The weight of the bridge is 1.6×10^6 N. Each supporting pillar has a cross sectional area of 0.8 m^2 .

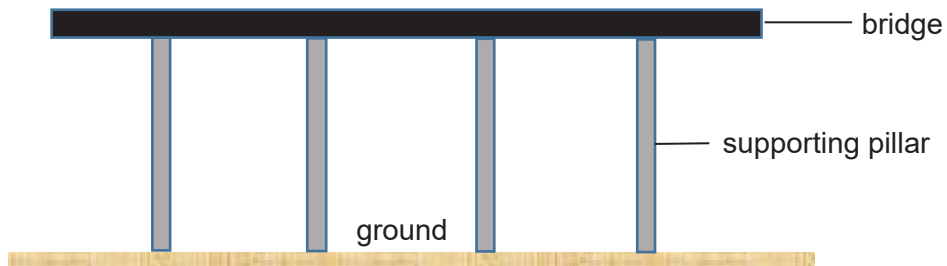

Fig. 1.1

- (a) Explain the term *pressure*.

.....

[1]

- (b) Calculate the pressure exerted on each supporting pillar.

pressure = N/m²

[2]

- (c) Table 1.2 shows two possible types of materials that could be used to make the supporting pillars for the bridge and the maximum pressure these materials can support.

Table 1.2

Raw material	Maximum pressure that raw material can support / N/m ²
Reinforced concrete	400 000
Stainless steel	480 000

Based on your calculation in (b) and data in Table 1.2, suggest and explain if reinforced concrete and stainless steel are suitable raw materials to make the supporting pillars.

.....

.....

.....

.....

[2]

- B2** Fig. 2.1 shows a waiter carrying a tray of drinks.



Fig. 2.1

- (a) Explain the meaning of the term *work done*.

.....

.....

[1]

- (b) Is there work done by the waiter on the tray of drinks? Explain your answer.

.....

.....

.....

[2]

[Turn over

- (c) The waiter climbs up a flight of stairs and takes a rest when he reached the top as shown in Fig. 2.2.

If the mass of the waiter is 70 kg and the mass of the tray of drinks is 500 g, calculate the total work done by the man when he carries the tray of drinks and climbs up the stairs.

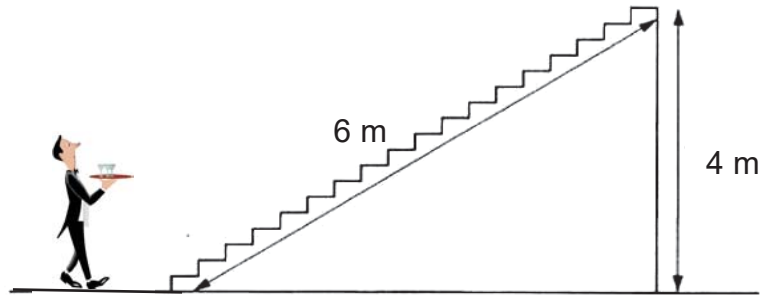
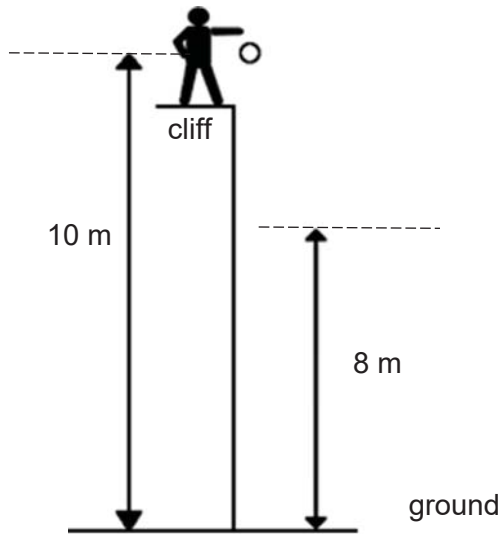

Fig. 2.2

work done = J [2]

B3 Fig. 3.1 shows a man dropping a 3 kg rubber ball off a cliff at a height of 10 m above the ground. The ball only bounce to a height of 8 m above the ground.

For
Examiner's
Use



(Diagram not drawn to scale)

Fig. 3.1

(a) State the principle of conservation of energy.

.....

[1]

(b) Other than air resistance, give one reason for the ball **not** bouncing as high as the height from which it was dropped.

.....

[1]

(c) Calculate the maximum gravitational potential energy of the ball after the first bounce. The gravitational field strength $g = 10\text{N/kg}$.

gravitational potential energy = J

[1]

[Turn over

(d) Find the energy lost by the ball after the first bounce

*For
Examiner's
Use*

energy loss = J [2]

B4 A teacher drops a small piece of grey metal into a glass jar of pale green gas. The grey solid burns with bright yellow flame, and a white powder is produced. The pale green gas is poisonous. The white powder formed is the compound sodium chloride which is the table salt commonly used for cooking.

(a) Define an *element*.

.....
.....
.....

[2]

(b) State the chemical symbols for the two elements present in sodium chloride.

.....

[1]

(c) From the information above, suggest two pieces of evidence to show that sodium chloride is a compound.

.....
.....
.....
.....

[2]

[Turn over

- B5** Sugar crystals can dissolve in water to form a sugar solution. A series of experiments were carried out to investigate the rate of dissolving of 20g of sugar crystals in 200cm³ of water in various conditions. Table 5.1 records the data gathered from these experiments.

Table 5.1

experiment	temperature of water (°C)	particle size of sugar crystals	time taken for all sugar crystals to dissolve (min)
1	30	fine powder	5
2	30	big pieces	7
3	40	fine powder	3

- (a) From the data recorded in Table 5.1 above, which two experiments (1, 2 or 3) would you choose to test the following hypothesis?

(i) The smaller the particle sizes of sugar crystals, the faster the rate of dissolving.

..... [1]

(ii) The higher the temperature, the faster the rate of dissolving.

..... [1]

- (c) State **another** way to increase the rate of dissolving for all three experiments.

..... [1]

- B6** Steel and rust are both substances made from iron. Steel is a mixture made up of iron and carbon, while rust is a compound formed between iron and oxygen.

Compare two differences between steel and rust.

..... [2]

B7 (a) Name the process by which water moves in and out of a plant cell.

.....

[1]

(b) Raisins are dried fruit. They are made by leaving grapes to dry in the sun.

The diagram shows the structure of cell from a grape.

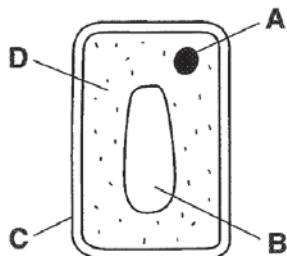

Water is lost from the cells when the grapes are left in the sun. Each cell keeps its shape and does not shrink very much as water moves out from it.

Which part, **A**, **B**, **C** or **D**, helps a cell to keep its shape as it loses water?

.....

[1]

(c) A student weighs 10 raisins and puts them into a dish containing distilled water, as shown in the diagram.



After one hour, the raisins are removed, blotted dry and reweighed.

The results are shown in Table 7.1 below.

Table 7.1

mass of raisins before being placed in distilled water/ g	2.0
mass of raisins after being placed in distilled water/ g	5.6

(i) Calculate the change in mass after the raisins were placed in sugar solution.

change in mass =

[1]

[Turn over

- (ii) Using the data in Table 7.1, state and explain what has happened to the raisins after one hour.

statement

[1]

explanation

[2]

B8 Fig. 8.1 shows human cheek cells.

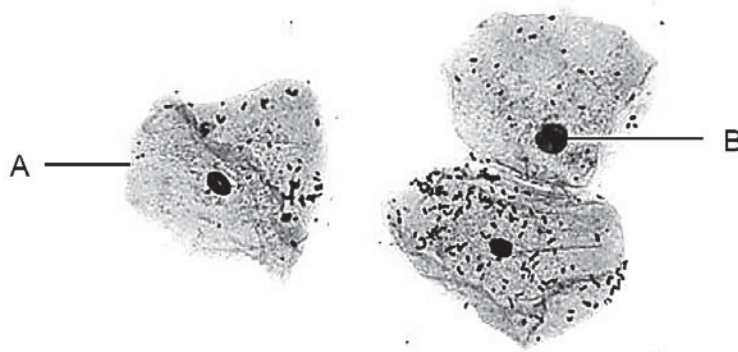

Fig. 8.1

- (a) Name the structures labelled **A** and **B**.

A

[1]

B

[1]

- (b) (i) Describe two ways in which the structure of a red blood cell is different from cheek cells as seen in Fig. 8.1.

1

2

[2]

- (ii) Identify one of the differences from your answer in (b)(i) and describe how it helps the red blood cell carry out its function.

.....

.....

[1]

B9 (a) The figure below shows the cross sections of different blood vessels **P**, **Q** and **R**.

*For
Examiner's
Use*

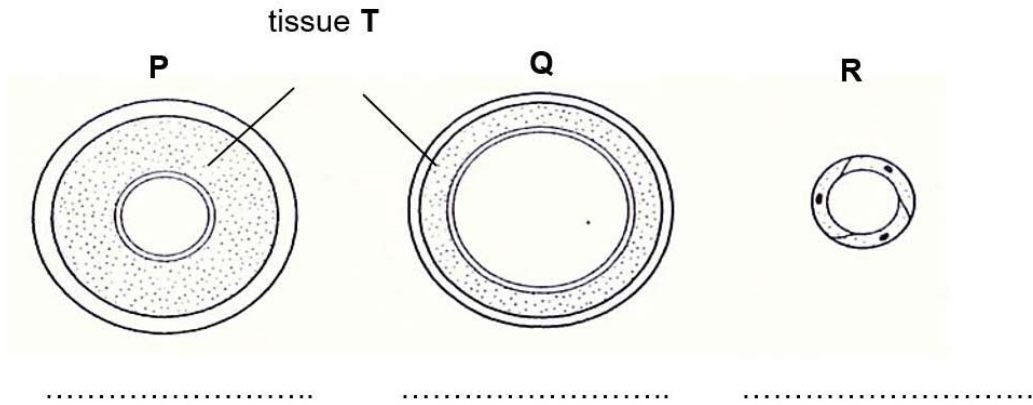

On the figure above, label the blood vessels **P**, **Q** and **R**.

[2]

(b) Suggest why tissue **T** is thicker in blood vessel **P** than in blood vessel **Q**.

.....

[1]

(c) State the function of vessel **R**.

.....

[1]

[Turn over

Section C [30 marks]

Answer **all** the questions in the spaces provided

- C1 (a)** A chromatography was carried out on two types of fruit juices, **F1** and **F2** and four known coloured dyes, **W**, **X**, **Y** and **Z**. The solvent used is water. Dye W is found in a list of illegal dyes. The results are shown in the chromatogram below.

*For
Examiner's
Use*

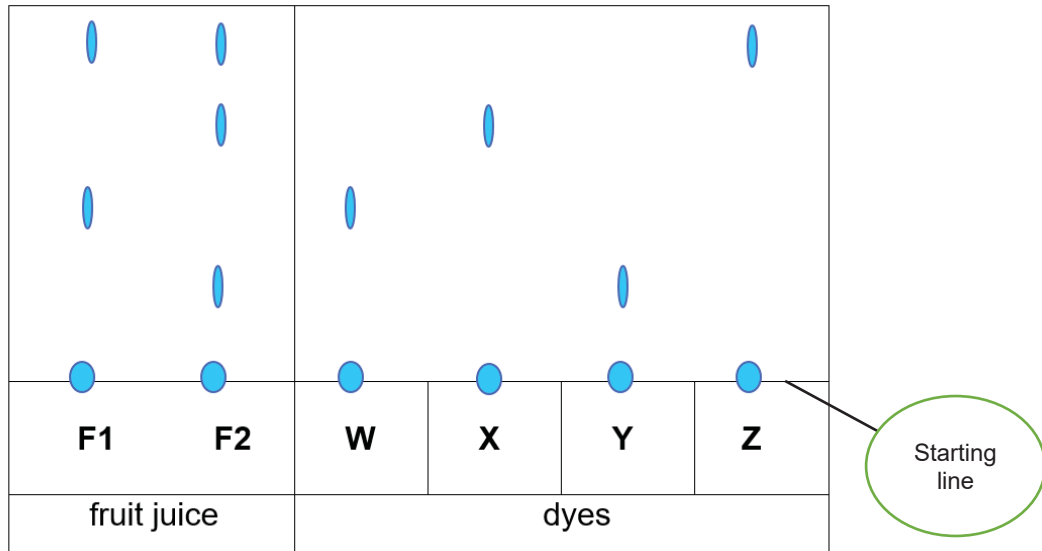

- (i) Which dye(s) is/are found in F2?

..... [1]

- (ii) Which dye is the most soluble in the solvent? Explain your answer.

.....

 [2]

- (iii) Which fruit juice(s) is / are unsafe for consumption? Give your reason.

.....
 [2]

- (iv) Explain why the starting line must be drawn in pencil.

.....
 [1]

- (b) You are given a solid mixture of common salt, iron filings and chalk. Some properties of the substances are listed in the table below.

For
Examiner's
Use

substance	appearance	solubility in water	attracted to magnet
common salt	tiny crystal	soluble	no
iron filings	dark grey powder	insoluble	yes
calcium carbonate	white powder	insoluble	no

Write the procedures to describe how you would obtain the dry iron filings and dry common salt from the mixture.

.....

.....

.....

.....

.....

.....

.....

.....

[4]

[Turn over

C2 A student performed an experiment to determine the *density* of a liquid.

The following data was recorded:

- Mass of empty measuring cylinder = 102.53 g
- Mass of cylinder and liquid = 223.09 g
- Volume of the liquid = 150 cm³

(a) Define *density* and state its SI unit.

.....

[2]

(b) Calculate the density of the liquid.

density = g/cm³

[2]

(c) The student did another experiment in which he varied the volume of a certain liquid **A** and measured the corresponding mass. He repeated this procedure for two other liquids **B** and **C**. He then plotted a graph of mass against volume for the three liquids as shown in Fig. 2.1.

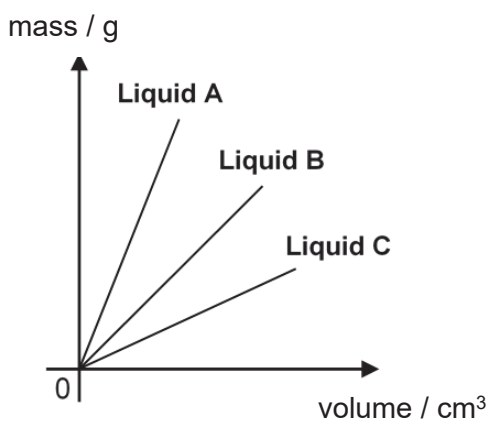

Fig. 2.1

(i) State the independent variable and dependent variable.

independent variable:

[1]

dependent variable:

[1]

- (ii) State which liquid has the highest density, and give a reason for your answer.

*For
Examiner's
Use*

.....

.....

.....

[2]

- (iii) Liquid **A**, **B** and **C** are mixed together in a measuring cylinder and three layers were observed.

On the diagram below, label the positions of the three liquids (**A**, **B**, **C**).

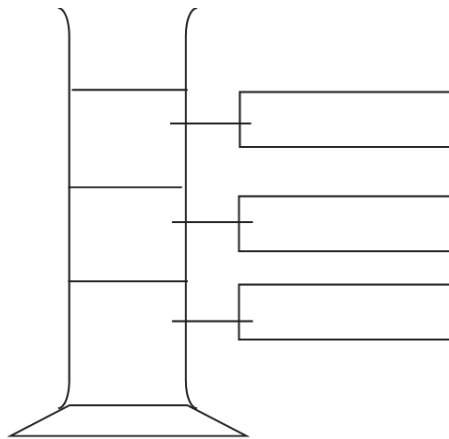

[2]

[Turn over

C3 Fig. 3.1 shows the human digestive system.

For
Examiner's
Use

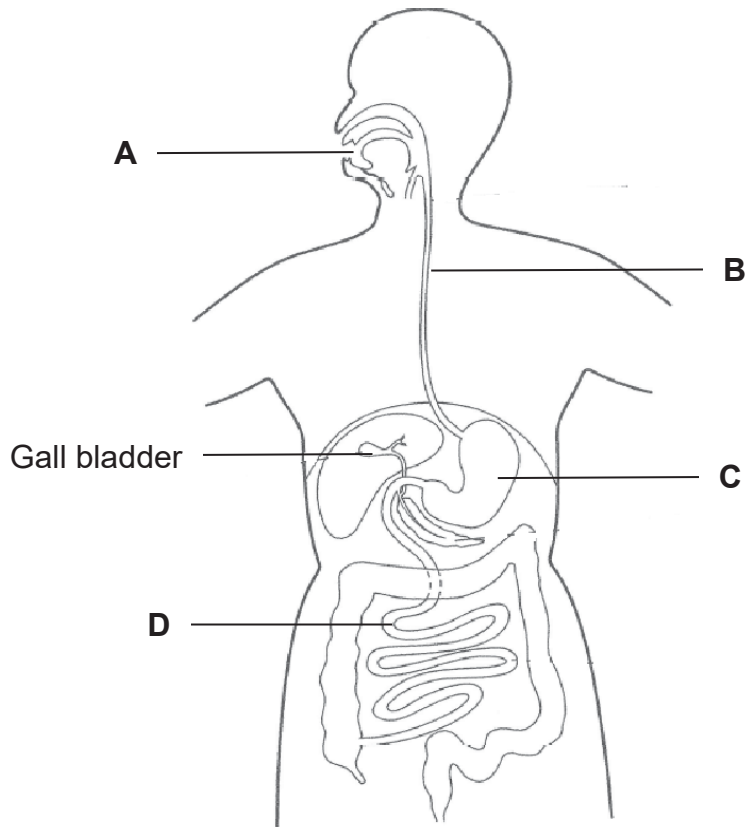

Fig. 3.1

(a) Name the organs labelled **B**, **C** and **D**.

B

C

D

[3]

(b) Both physical and chemical digestion takes place in the alimentary canal.
Explain why physical digestion is important.

.....
.....
.....

[2]

(c) "Food is not digested in part **B**".

Do you agree with the above statement? Explain your reasoning.

.....
.....

[1]

(d) The gall bladder stores bile.

(i) In the box below, draw a diagram to show the effect of bile on fat digestion.

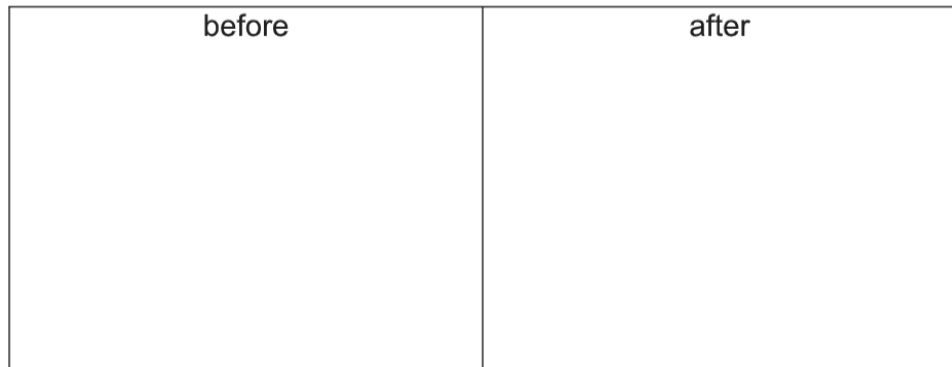

[1]

(ii) Based on your drawing in (d)(i), explain how the action of bile helps in the complete digestion of fats.

.....

.....

.....

[2]

(iii) Fig. 3.2 shows three different mixtures of starch, protein and fat molecules in different parts of the human alimentary canal.

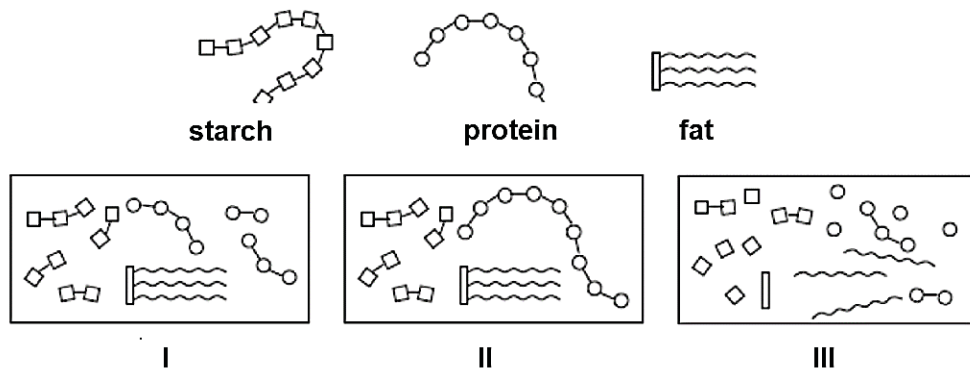

Fig. 3.2

Identify which mixture (I, II or III) in Fig. 3.2 would be found at parts **A** and **C**?

A

C

[1]

End of Paper

