

*Visit*

**FREETESTPAPER.com**

*for more papers*



Website: [freetestpaper.com](http://www.freetestpaper.com)



[Facebook.com/freetestpaper](https://www.facebook.com/freetestpaper)



[Twitter.com/freetestpaper](https://www.twitter.com/freetestpaper)



**BEATTY SECONDARY SCHOOL  
END-OF-YEAR EXAMINATION 2022  
SECONDARY TWO EXPRESS**

CANDIDATE  
NAME

CLASS

REGISTER  
NUMBER

## **MATHEMATICS**

Paper 1

Setter:

**6 October 2022  
1 hour 30 minutes**

Candidates answer on the Question Paper  
Additional Materials: Nil

### **READ THESE INSTRUCTIONS FIRST**

Write your name, class and register number on all the work you hand in.  
Write in dark blue or black pen.  
You may use an HB pencil for any diagrams or graphs.  
Do not use staples, paper clips, glue or correction fluid.

Answer **all** the questions.

The number of marks is given in brackets [ ] at the end of each question or part question.

If working is needed for any question, it must be shown with the answer.

Omission of essential working will result in loss of marks.

The total of the marks for this paper is 50.

The use of an approved scientific calculator is expected, where appropriate.

If the degree of accuracy is not specified in the question, and if the answer is not exact, give the answer to three significant figures. Give answers in degrees to one decimal place.

For  $\pi$ , use either your calculator value or 3.142.

**For Examiner's Use**

This document consists of **13** printed pages and **1** blank page.

- 1 There are 7 red balls, 10 yellow balls, and 8 blue balls in a bag.  
A ball is chosen at random from the bag.  
(a) Find the probability that the chosen ball is black.

*Answer:* ..... [1]

- (b) Find the probability that the chosen ball is either red or yellow.

*Answer:* ..... [1]

- (c) Some green balls are added into the bag such that the probability of choosing a yellow ball at random is 0.2  
Find the new total number of balls in the bag.

*Answer:* ..... balls [2]

---

- 2 (a) Factorise  $2x^2 + 3y - 2xy - 3x$  completely.

Answer: \_\_\_\_\_ [2]

- (b) Hence, or otherwise, simplify  $\frac{(y-x)(3y+2x)}{2x^2+3y-2xy-3x}$ .

Answer: \_\_\_\_\_ [2]

---

3 (a) Expand  $\left(x + \frac{1}{x}\right)^2$ .

Answer: ..... [1]

(b) Given that  $x^2 + \frac{1}{x^2} = 7$  and  $x > 0$ , find the value of

(i)  $x + \frac{1}{x}$

Answer: ..... [1]

(ii)  $\left(x - \frac{1}{x}\right)^2$

Answer: ..... [1]

(c) Find the value of  $\sqrt{200.5^2 - 199.5^2}$  using factorisation.

Answer: ..... [2]

- 4 (a)  $y$  is inversely proportional to the square of  $x$ .  
It is known that  $y = 12$  for a particular value of  $x$ .  
When  $x$  is increased by 100%, find
- (i) the value of  $y$ ,

Answer:  $y =$  \_\_\_\_\_ [2]

- (ii) the percentage decrease in the value of  $y$ .

Answer: \_\_\_\_\_ % [2]

- (b) The graph below shows the relationship between two variables  $p$  and  $q$ .

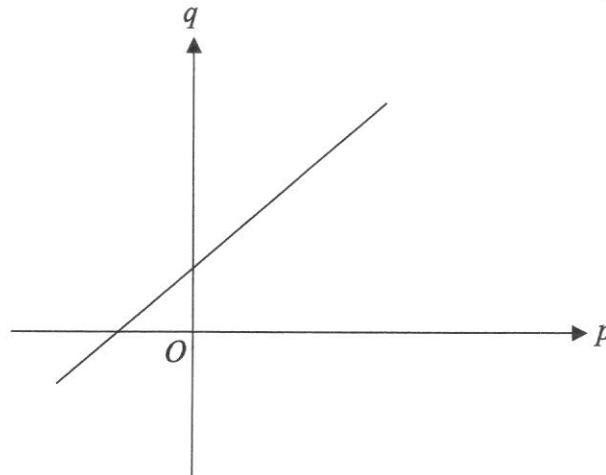

Grace claims that  $q$  is directly proportional to  $p$ . Do you agree? Explain your answer with reference to the graph.

Answer: I agree/disagree because \_\_\_\_\_

\_\_\_\_\_

\_\_\_\_\_ [2]

5 Solve the following simultaneous equations.

$$2p - 5q = 4.75$$

$$3p + 8q = -4.5$$

*Answer:*  $p =$  \_\_\_\_\_

$q =$  \_\_\_\_\_ [3]

---

- 6 In the diagram,  $BC = 12$  cm,  $AC = 35$  cm, and  $AB = 37$  cm.

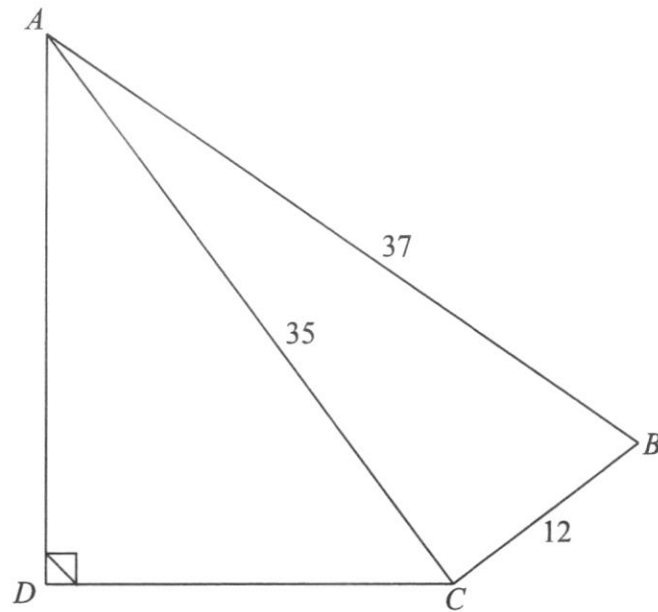

- (a) Show that angle  $ACB = 90^\circ$ .

Answer: \_\_\_\_\_  
 \_\_\_\_\_  
 \_\_\_\_\_  
 \_\_\_\_\_ [2]

- (b) Write down the exact value of  $\tan \hat{BAC}$ .

Answer: \_\_\_\_\_ [1]

- (c) Given that  $\cos \hat{CAD} = 0.8$ , find the length of  $AD$ .

Answer: \_\_\_\_\_ cm [2]

(d) Find angle  $BAD$ .

*Answer:* ..... ° [3]

(e) Find the shortest distance from  $D$  to  $AC$ .

*Answer:* ..... cm [2]

---

- 7 The back-to-back stem-and-leaf diagram shows the scores of students in two different classes for the same Mathematics quiz.

Class A	Stem	Class B
4 0	5	2 6 8 9
9 9 6	6	2 5 8 8 9 9
9 8 5 3 2 0	7	4 6 7 8 8 9
9 9 9 7 7 6 6 4 2	8	0 3 4 6 7 7
9 8 8 7 6 6 3 2 0	9	0 2 7 8
	10	0 0 0

Key 0 | 5 | 2 means 50 marks for Class A and 52 marks for Class B

- (a) Which class had the student with the highest score?

*Answer:* Class \_\_\_\_\_ [1]

- (b) Which class had the student with the lowest score?

*Answer:* Class \_\_\_\_\_ [1]

- (c) Find the modal score of both classes.

*Answer:* Class A \_\_\_\_\_

Class B \_\_\_\_\_ [1]

- (d) Find the percentage of students who scores 70 marks and above in each class.

*Answer:* Class A \_\_\_\_\_ %

Class B \_\_\_\_\_ % [2]

- (e) Is the mean or median a better representation of the central tendency of the scores of the students in each class? Explain your answer clearly.

*Answer:* \_\_\_\_\_

\_\_\_\_\_

\_\_\_\_\_

\_\_\_\_\_ [2]

- 8 In the diagram, the two quadrilaterals are congruent.  
 $GH = KL = 10$  cm,  $HI = 12$  cm, angle  $HIJ =$  angle  $LMN = 140^\circ$ , angle  $GHI = 78^\circ$ , and angle  $HGJ = 92^\circ$ .

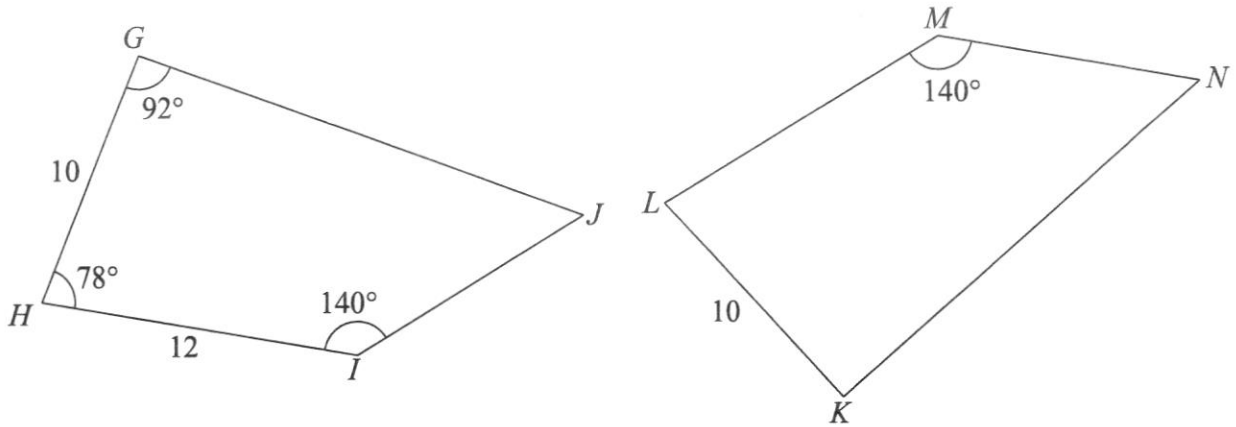

- (a) Name the quadrilateral congruent to  $GHIJ$ .

Answer: ..... [1]

- (b) Find the length of  $LM$ .

Answer: ..... cm [1]

- (c) Find angle  $LKN$ .

Answer: .....  $^\circ$  [1]

- (d) Find angle  $MNK$ .

Answer: .....  $^\circ$  [2]

- 9 Canals help regulate water flow and prevent floods from occurring in Singapore.

A section of a canal can be modelled as an isosceles trapezoid attached to the top of a half-cylinder, as shown in the diagram below.

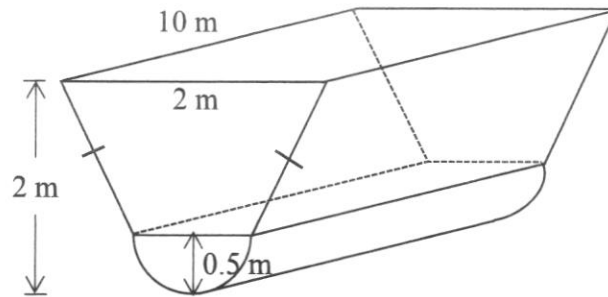

The cross section of the canal section is made up of a trapezium and a semicircle.

The length of the canal section is 10 m.

The radius of the semicircle is 0.5 m.

The length of the longer side of the trapezium is 2 m.

The vertical height measured from the bottom of the semicircle to the top of the trapezium is 2 m.

- (a) Find the volume of the canal section.

Answer: ..... m<sup>3</sup> [3]

- (b) Find the surface area of the canal section in contact with water when the canal section is 100% filled with water.

*Answer:* ..... m<sup>2</sup> [3]

---



**BEATTY SECONDARY SCHOOL  
END-OF-YEAR EXAMINATION 2022  
SECONDARY TWO EXPRESS**

CANDIDATE  
NAME

CLASS

REGISTER  
NUMBER

**MATHEMATICS**

Paper 2

**10 October 2022  
1 hour 30 minutes**

Candidates answer on the Question Paper  
Additional Materials: NIL

**READ THESE INSTRUCTIONS FIRST**

Write your name, class and register number on all the work you hand in.  
Write in dark blue or black pen.  
You may use an HB pencil for any diagrams or graphs.  
Do not use staples, paper clips, glue or correction fluid.

Answer **all** questions.  
The number of marks is given in brackets [ ] at the end of each question or part question.

If working is needed for any question, it must be shown with the answer.  
Omission of essential working will result in loss of marks.  
The total of the marks for this paper is 50.

The use of an approved scientific calculator is expected, where appropriate.  
If the degree of accuracy is not specified in the question, and if the answer is not exact, give the answer to three significant figures. Give answers in degrees to one decimal place.  
For  $\pi$ , use either your calculator value or 3.142.

**For Examiner's Use**

This document consists of **13** printed pages and **1** blank page.

[Turn Over

**Mathematical Formulae***Mensuration*

Curved Surface area of a cone =  $\pi r l$

Surface area of a sphere =  $4\pi r^2$

Volume of a cone =  $\frac{1}{3}\pi r^2 h$

Volume of a sphere =  $\frac{4}{3}\pi r^3$

1 (a) Factorise  $2x^2 + 7x + 5$ .

*Answer* ..... [1]

(b) **Hence**, deduce two factors of 20705.

*Answer* ..... and ..... [2]

2 (a) Solve the inequality  $\frac{1}{5}(x+2) \geq x-9$ .

*Answer* ..... [2]

(b) Two of the sides of a triangle are 14 cm and 8 cm and the third side has a length of  $p$  cm where  $p$  is an integer. Write down an inequality that must be satisfied by  $p$ .

*Answer* ..... [2]

3

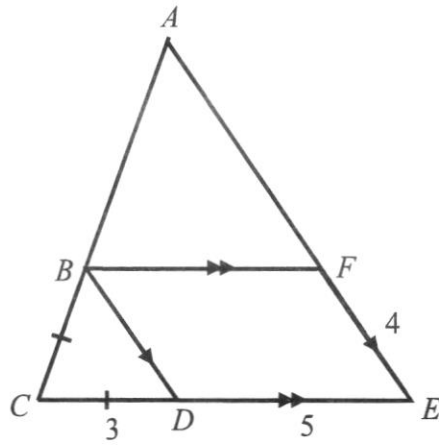

In the diagram,  $BDEF$  is a parallelogram,  $BC = CD = 3$  m,  $DE = 5$  m and  $EF = 4$  m. Given that triangle  $BCD$  is similar to triangle  $ACE$ , find the value of  $BA + AF$ .

Answer ..... m [2]

4

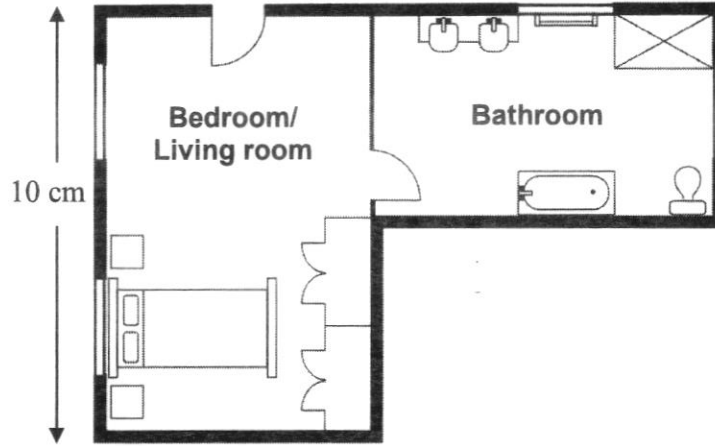

The diagram shows the floor plan of a studio apartment. On the plan, the length of the bedroom/living room is 10 cm long and the area of the bathroom is 30 cm<sup>2</sup>. The actual length of the bedroom/living room is 5 m.

Find

(a) the scale of the floor plan,

*Answer* ..... [1]

(b) the actual area, in square metres, of the bathroom.

*Answer* ..... m<sup>2</sup> [2]

5 Alvin buys a bicycle at cost price  $\$x$ .

- (a) He marks up the price of the bicycle to make a 60% profit. He then sells the bicycle to his friend at a discount of 40% on the marked-up price.  
Does Alvin make a profit, loss or break even? Explain your answer.

*Answer*

[2]

- (b) Alvin decides to mark up the cost price of the bicycle by  $k\%$  such that he makes a profit when he offers 45% discount on the new marked price.  
Find the minimum value of  $k$  such that  $k$  is an integer. Show your workings clearly.

*Answer* ..... % [2]

- 6 When typing a report, Ben records the number of errors he made on each page of the report in the table as shown below.

Number of errors	0	1	2	3	4	5	6
Number of pages	1	3	10	$x$	4	3	2

- (a) Write down the least possible value of  $x$  if the median is 3.

*Answer*  $x = \dots\dots\dots$  [1]

- (b) Write down the greatest possible value of  $x$  if the mode is 2.

*Answer*  $x = \dots\dots\dots$  [1]

- (c) Given that the mean number of errors Ben made is 2.88, find the value of  $x$ .

*Answer*  $x = \dots\dots\dots$  [2]

7 (a) Simplify  $\frac{2x^2}{7y} \div \frac{4x^2}{21y^2} \times \frac{8y}{3x}$ .

*Answer* ..... [2]

(b) Express as a single fraction in its simplest form

$$\frac{4}{x-3} - \frac{x+5}{x^2-7x+12}$$

*Answer* ..... [3]

- 8 In a competition, Kayden walks at an average speed of  $(x+1)$  km/h for  $2x$  hours and cycles at an average speed of  $2(2x-3)$  km/h for  $(x+3)$  hours.

(a) Write down an expression, in terms of  $x$ , for the distance he walks.

*Answer* ..... km [1]

(b) Write down an expression, in terms of  $x$ , for the distance he cycles.

*Answer* ..... km [1]

(c) Given that Kayden covers a distance of 172 km, write down an equation, in terms of  $x$ , and show that it reduces to

$$3x^2 + 4x - 95 = 0.$$

*Answer*

[3]

(d) Solve the equation  $3x^2 + 4x - 95 = 0$ .

*Answer*  $x = \dots\dots\dots$  or  $\dots\dots\dots$  [2]

(e) Hence, find the time taken Kayden takes to complete the competition.

*Answer* ..... h [1]

- 9 The variables  $x$  and  $y$  are connected by the equation  $y = -5x + x^2 - 2$ .  
Some corresponding values of  $x$  and  $y$  are given in the following table.

$x$	-1	0	1	2	3	5
$y$	$p$	-2	-6	-8	-8	-2

- (a) Calculate the value of  $p$ .

*Answer*  $p = \dots\dots\dots$  [1]

- (b) On the grid below, draw the graph of  $y = -5x + x^2 - 2$  for  $-1 \leq x \leq 5$ .

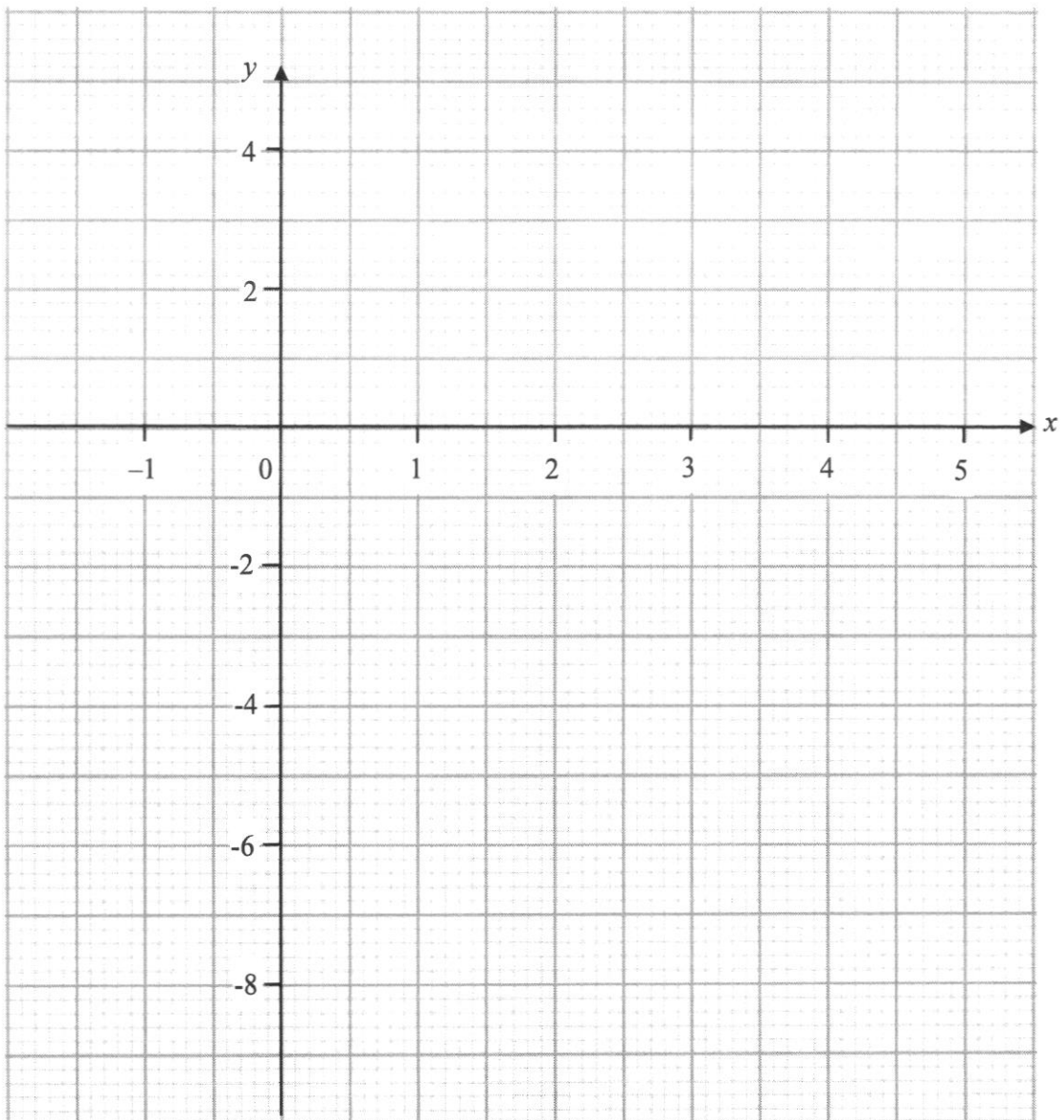

[3]

- (c) Use your graph to find  
 (i) the minimum value of  $y$ ,

*Answer* ..... [1]

- (ii) the equation of the line of symmetry of the curve,

*Answer* ..... [1]

- (iii) the values of  $x$  when  $y = -4$ .

*Answer*  $x = \dots\dots\dots$  and  $\dots\dots\dots$  [2]

- (d) Lynn claims that she knows the value of  $y$  when  $x = 6$  by reading from the graph.  
 Do you agree with her? Explain your answer.

*Answer*

[2]

- 10 A cylindrical container has a diameter of 50 cm. A solid cone and a solid hemisphere with a total volume of  $3670 \text{ cm}^3$  are placed in the container. The height of the cone is equal to the radius of the hemisphere. Water is poured into the container at a rate of  $4973 \text{ cm}^3/\text{s}$ .

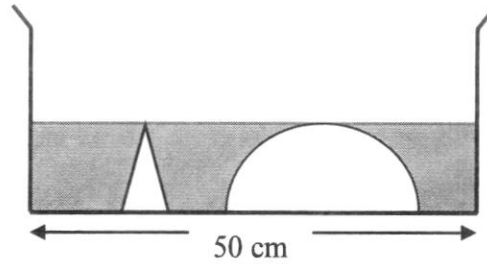

After 4 s, the water just covers the vertex of the cone.

- (a) Show that the depth of the water is 12.0 cm.

*Answer*

[1]

- (b) Find the radius of the cone.

*Answer* ..... cm [3]

- (c) Calculate the total surface area of the cone and hemisphere that is in contact with the water.

*Answer* ..... cm<sup>2</sup> [3]

---

- 1 (a) 0  
(b)  $\frac{17}{25}$   
(c) 50
- 2 (a)  $(x-y)(2x-3)$   
(b)  $-\frac{3y+2x}{2x-3}$
- 3 (a)  $x^2 + 2 + \frac{1}{x^2}$   
(b) (i) 3  
(ii) 5  
(c) 20
- 4 (a) (i) 3  
(ii) 75%  
(b) Disagree. Graph does not pass through origin.
- 5  $p = 0.5, q = -0.75$ .
- 6 (b)  $\frac{12}{35}$   
(c) 28  
(d) 55.8  
(e) 16.8
- 7 (a) B  
(b) A  
(c) 89, 100  
(d) 82.8, 65.5  
(e) Mean. Mean accounts for all the values in the data.
- 8 (a) *KLMN*  
(b) 12  
(c) 92  
(d) 50
- 9 (a) 26.4  
(b) 47.3

## 2022 Sec 2 EOY P2 Express Answer Key

Question		Answer Key
1	(a)	$(2x+5)(x+1)$
	(b)	Factors are 205 and 101
2	(a)	$x \leq 11.75$
	(b)	$7 \leq p \leq 21$ $6 < p < 22$ (correct min/ max and respective inequality sign)
3		$11\frac{2}{3} \text{ m}$
4	(a)	1 : 50
	(b)	$7.5 \text{ m}^2$
5	(a)	$0.6 \times 1.6 \times x = 0.96x$ Since $0.96x < x$ , Alvin will make a loss.
	(b)	82%
6	(a)	6
	(b)	9
	(c)	2
7	(a)	$\frac{4y^2}{x}$
	(b)	$\frac{3x-21}{(x-3)(x-4)}$
8	(a)	$2x(x+1)$
	(b)	$2(2x-3)(x+3)$
	(c)	$2x(x+1) + 2(2x-3)(x+3) = 172$ $2x^2 + 2x + 4x^2 + 12x - 6x - 18 - 172 = 0$ $6x^2 + 8x - 190 = 0$ $3x^2 + 4x - 95 = 0$ (shown)
	(d)	5 or $-\frac{19}{3}$
	(e)	18 h

9	(a)	4
	(b)	
	(c)(i)	-8.1 to -8.3
	(c)(ii)	$x = 2.5$
	(c)(iii)	0.3 to 0.5 and 4.5 to 4.7
	(d)	Yes. Since the curve drawn in part (b) is symmetrical and that $y = 4$ when $x = -1$ , ----- therefore $y = 4$ when $x = 6$ or $y$ is the same value when $x = -1$ and $x = 6$ -----
10	(a)	$\pi(25^2)h = (4 \times 4973) + 3670$ $h = 12.00002$ $= 12.0 \text{ cm (3 s.f.) (shown)}$
	(b)	2.01 cm
	(c)	982 cm <sup>2</sup>

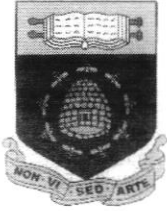

BEATTY SECONDARY SCHOOL  
 END-OF-YEAR EXAMINATION 2022  
 SECONDARY TWO EXPRESS

**MARK SCHEME**

CANDIDATE  
 NAME

CLASS

REGISTER  
 NUMBER

**MATHEMATICS**

Paper 1

6 October 2022

Setter: Mr Teo Chye Keong

1 hour 30 minutes

Candidates answer on the Question Paper

Additional Materials: Nil

**READ THESE INSTRUCTIONS FIRST**

Write your name, class and register number on all the work you hand in.  
 Write in dark blue or black pen.  
 You may use an HB pencil for any diagrams or graphs.  
 Do not use staples, paper clips, glue or correction fluid.

Answer **all** the questions.  
 The number of marks is given in brackets [ ] at the end of each question or part question.

If working is needed for any question, it must be shown with the answer.  
 Omission of essential working will result in loss of marks.  
 The total of the marks for this paper is 50.

The use of an approved scientific calculator is expected, where appropriate.  
 If the degree of accuracy is not specified in the question, and if the answer is not exact,  
 give the answer to three significant figures. Give answers in degrees to one decimal place.  
 For  $\pi$ , use either your calculator value or 3.142.

For Examiner's Use

This document consists of **13** printed pages and **1** blank page.

3

- 1 There are 7 red balls, 10 yellow balls, and 8 blue balls in a bag.  
A ball is chosen at random from the bag.

(a) Find the probability that the chosen ball is black.

$$0 \quad \text{---- B1}$$

Answer: \_\_\_\_\_ [1]

- (b) Find the probability that the chosen ball is either red or yellow.

$$\frac{17}{25} \quad \text{---- B1}$$

Answer: \_\_\_\_\_ [1]

- (c) Some green balls are added into the bag such that the probability of choosing a yellow ball at random is 0.2  
Find the new total number of balls in the bag.

Let number of green balls added be  $x$ .

$$\frac{10}{25+x} = 0.2 \quad \text{---- M1}$$

$$10 = 5 + 0.2x$$

$$x = 25$$

$$\text{total} = 50 \quad \text{---- A1}$$

Answer: \_\_\_\_\_ balls [2]

- 2 (a) Factorise  $2x^2 + 3y - 2xy - 3x$  completely.

$$\begin{aligned} 2x^2 + 3y - 2xy - 3x &= 2x(x-y) - 3(x-y) \quad \text{---- M1 (OE)} \\ &= (x-y)(2x-3) \quad \text{---- A1} \end{aligned}$$

Answer: \_\_\_\_\_ [2]

- (b) Hence, or otherwise, simplify  $\frac{(y-x)(3y+2x)}{2x^2+3y-2xy-3x}$ .

$$\begin{aligned} \frac{(y-x)(3y+2x)}{2x^2+3y-2xy-3x} &= \frac{-(x-y)(3y+2x)}{(x-y)(2x-3)} \quad \text{---- M1 change to } (x-y) \text{ (OE)} \\ &= -\frac{3y+2x}{2x-3} \quad \text{---- A1 (OE)} \end{aligned}$$

Answer: \_\_\_\_\_ [2]

---

3 (a) Expand  $\left(x + \frac{1}{x}\right)^2$ .

$$\left(x + \frac{1}{x}\right)^2 = x^2 + 2 + \frac{1}{x^2} \quad \text{---- B1}$$

Answer: \_\_\_\_\_ [1]

(b) Given that  $x^2 + \frac{1}{x^2} = 7$  and  $x > 0$ , find the value of

(i)  $x + \frac{1}{x}$

$$x^2 + 2 + \frac{1}{x^2} = 7 + 2 = 9$$

$$x + \frac{1}{x} = 3 \quad \text{---- B1}$$

Answer: \_\_\_\_\_ [1]

(ii)  $\left(x - \frac{1}{x}\right)^2$

$$\left(x - \frac{1}{x}\right)^2 = x^2 - 2 + \frac{1}{x^2}$$

$$= 7 - 2$$

$$= 5 \quad \text{---- B1}$$

Answer: \_\_\_\_\_ [1]

(c) Find the value of  $\sqrt{200.5^2 - 199.5^2}$  using factorisation.

$$\sqrt{200.5^2 - 199.5^2} = \sqrt{(200.5 - 199.5)(200.5 + 199.5)} \quad \text{---- M1}$$

$$= \sqrt{(1)(400)}$$

$$= 20 \quad \text{---- A1}$$

Answer: \_\_\_\_\_ [2]

## 6

- 4 (a)  $y$  is inversely proportional to the square of  $x$ .  
It is known that  $y = 12$  for a particular value of  $x$ .  
When  $x$  is increased by 100%, find  
(i) the value of  $y$ ,

$$12 = \frac{k}{a^2}$$

$$k = 12a^2 \quad \text{---- M1}$$

sub  $x = 2a$

$$y = \frac{12a^2}{(2a)^2}$$

$$= 3 \quad \text{---- A1}$$

Answer:  $y =$  \_\_\_\_\_ [2]

- (ii) the percentage decrease in the value of  $y$ .

$$\text{percentage decrease} = \frac{12-3}{12} \times 100 \quad \text{---- M1 (FT their } y)$$

$$= 75\% \quad \text{---- A1}$$

Answer: \_\_\_\_\_ % [2]

- (b) The graph below shows the relationship between two variables  $p$  and  $q$ .

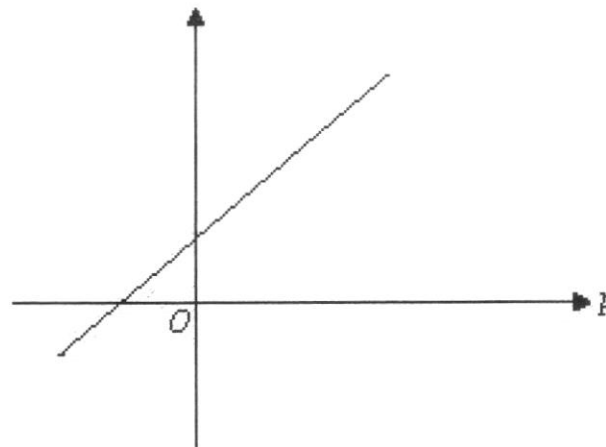

Grace claims that  $q$  is directly proportional to  $p$ . Do you agree? Explain your answer with reference to the graph.

Answer: I agree/disagree because --- B1  
 \_\_\_\_\_  
 The graph does not pass through the origin, so  $q$  is not directly  
 \_\_\_\_\_  
 proportional to  $p$ . --- B1 [2]

- 5 Solve the following simultaneous equations.

$$2p - 5q = 4.75$$

$$3p + 8q = -4.5$$

$$3\left(\frac{4.75+5q}{2}\right) + 8q = -4.5 \quad \text{---- M1 (OE)}$$

$$7.125 + 7.5q + 8q = -4.5$$

$$15.5q = -11.625$$

$$q = -0.75 \quad \text{---- A1 (OE)}$$

$$p = \frac{4.75 + 5(-0.75)}{2} = 0.5 \quad \text{---- A1 (OE)}$$

Answer:  $p =$  \_\_\_\_\_

$q =$  \_\_\_\_\_ [3]

- 6 In the diagram,  $BC = 12$  cm,  $AC = 35$  cm, and  $AB = 37$  cm.

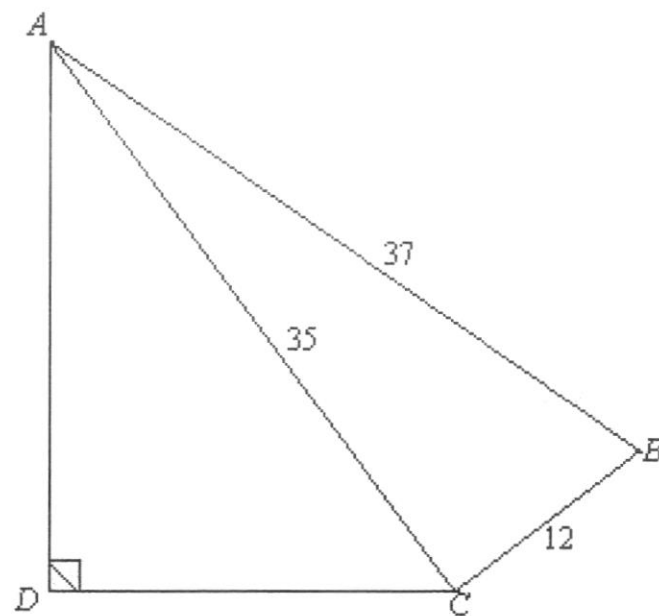

- (a) Show that angle  $ACB = 90^\circ$ .

Answer:  $AB^2 = 37^2 = 1369$

$AC^2 + BC^2 = 35^2 + 12^2 = 1369$  ---- M1

Since  $AB^2 = AC^2 + BC^2$ , triangle  $ABC$  is a right-angled triangle and

angle  $ACB = 90^\circ$  by the Converse of Pythagoras' Theorem. ----- A1 [2]

- (b) Write down the exact value of  $\tan \hat{BAC}$ .

$\frac{12}{35}$  ---- B1

Answer: \_\_\_\_\_ [1]

- (c) Given that  $\cos \hat{CAD} = 0.8$ , find the length of  $AD$ .

$\frac{AD}{35} = 0.8$  ---- M1

$AD = 28$  ---- A1

Answer: \_\_\_\_\_ cm [2]

- (d) Find angle  $BAD$ .

$$\hat{C}AD = \cos^{-1} 0.8 = 36.869^\circ \quad \text{---- M1}$$

$$\hat{B}AC = \cos^{-1} \frac{35}{37} = 18.924^\circ \quad \text{---- M1}$$

$$\hat{B}AD = 55.8^\circ \quad \text{----- A1}$$

Answer: \_\_\_\_\_ ° [3]

- (e) Find the shortest distance from  $D$  to  $AC$ .

Let the shortest distance from  $D$  to  $AC$  be  $h$  cm.

$$\sin 36.869^\circ = \frac{h}{28} \quad \text{---- M1 (FT their } \hat{C}AD)$$

$$h = 28 \sin 36.869^\circ = 16.8 \quad \text{---- A1}$$

Answer: \_\_\_\_\_ cm [2]

## 10

- 7 The back-to-back stem-and-leaf diagram shows the scores of students in two different classes for the same Mathematics quiz.

Class A	Stem	Class B
	5	2 6 8 9
	6	2 5 8 8 9 9
9 8 5 3 2 0	7	4 6 7 8 8 9
9 9 9 7 7 6 6 4 2	8	0 3 4 6 7 7
9 8 8 7 6 6 3 2 0	9	0 2 7 8
	10	0 0 0

Key 2 | 8 | 3 means 82 marks for Class A and 83 marks for Class B

- (a) Which class had the student with the highest score?

Answer: Class B ----- B1 [1]

- (b) Which class had the student with the lowest score?

Answer: Class A ----- B1 [1]

- (c) Find the modal score of both classes.

Answer: Class A 89

Class B 100 ----- B1 [1]

- (d) Find the percentage of students who scores 70 marks and above in each class.

Answer: Class A 82.8% --- B1

Class B 65.5% --- B1 [2]

- (e) Is the mean or median a better representation of the central tendency of the scores of the students in each class? Explain your answer clearly.

Answer: Mean is better. ----- B1

Mean takes into account all the values in the data sets. ----- B1

\_\_\_\_\_  
 \_\_\_\_\_ [2]

- 8 In the diagram, the two quadrilaterals are congruent.  
 $GH = KL = 10\text{ cm}$ ,  $HI = 12\text{ cm}$ , angle  $HJ = \text{angle } LMN = 140^\circ$ , angle  $GHI = 78^\circ$ , and angle  $HGJ = 92^\circ$ .

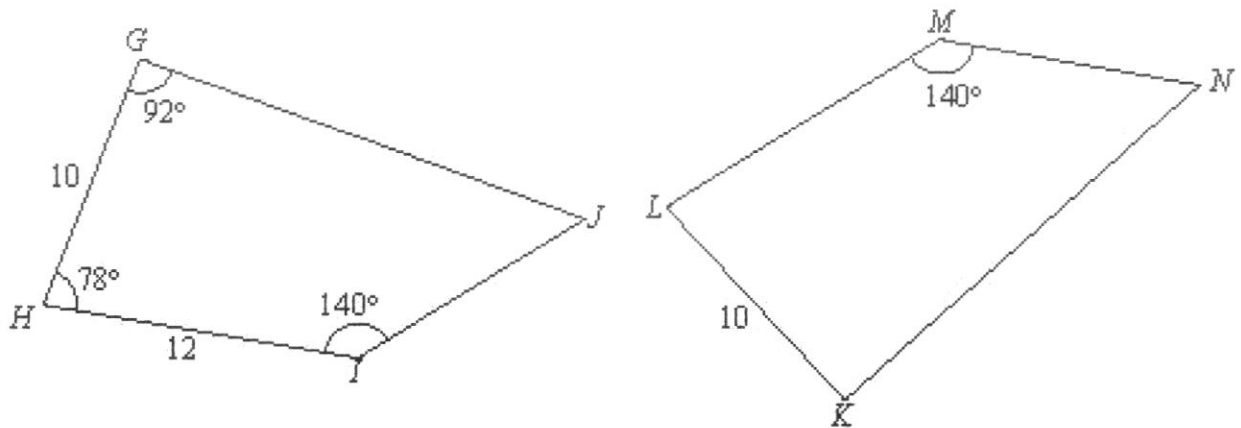

- (a) Name the quadrilateral congruent to  $GHJ$ .

Answer:  $KLMN$  ----- B1 [1]

- (b) Find the length of  $LM$ .

Answer: 12 ----- B1 cm [1]

- (c) Find angle  $LKN$ .

Answer: 92 ----- B1 ° [1]

- (d) Find angle  $MNK$ .

$$\begin{aligned} \hat{M}NK &= 360^\circ - 92^\circ - 78^\circ - 140^\circ \quad \text{---- M1} \\ &= 50^\circ \quad \text{---- A1} \end{aligned}$$

(or B2)

Answer: 50 ° [2]

[Turn Over

- 9 Canals help regulate water flow and prevent floods from occurring in Singapore.

A section of a canal can be modelled as an isosceles trapezoid attached to the top of a half-cylinder, as shown in the diagram below.

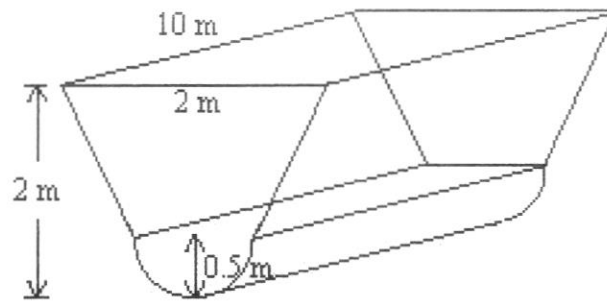

The cross section of the canal section is made up of a trapezium and a semicircle.  
 The length of the canal section is 10 m.  
 The radius of the semicircle is 0.5 m.  
 The length of the longer side of the trapezium is 2 m.  
 The vertical height measured from the bottom of the semicircle to the top of the trapezium is 2 m.

- (a) Find the volume of the canal section.

$$\text{trapezium} = \frac{1}{2}(2+1)(1.5) = 2.25 \quad \text{---- M1}$$

$$\text{semicircle} = \frac{1}{2}\pi(0.5)^2 = 0.125\pi \quad \text{---- M1}$$

$$\text{volume} = (2.25+0.125\pi)(10) = 26.4 \quad \text{---- A1}$$

Answer: \_\_\_\_\_ m<sup>3</sup> [3]

13

- (b) Find the surface area of the canal section in contact with water when the canal section is 100% filled with water.

$$\text{slant length of trapezium} = \sqrt{0.5^2 + 1.5^2} = \sqrt{2.5} \quad \text{---- M1}$$

$$\text{TSA} = \text{CSA of half-cylinder} + 2 \text{ rectangles}$$

$$= \frac{1}{2}(2\pi)(0.5)(10) + 2(\sqrt{2.5})(10) \quad \text{---- M1 either}$$

$$= 15.70796 + 31.62277$$

$$= 47.3 \text{ m}^2 \quad \text{---- A1}$$

Answer: \_\_\_\_\_ m<sup>2</sup> [3]

---



BEATTY SECONDARY SCHOOL  
END-OF-YEAR EXAMINATION 2022  
SECONDARY TWO EXPRESS

**MARKING SCHEME**

CANDIDATE  
NAME

CLASS

REGISTER  
NUMBER

## MATHEMATICS

Paper 2

10 October 2022  
1 hour 30 minutes

Candidates answer on the Question Paper  
Additional Materials: NIL

### READ THESE INSTRUCTIONS FIRST

Write your name, class and register number on all the work you hand in.  
Write in dark blue or black pen.  
You may use an HB pencil for any diagrams or graphs.  
Do not use staples, paper clips, glue or correction fluid.

Answer **all** questions.

The number of marks is given in brackets [ ] at the end of each question or part question.

If working is needed for any question, it must be shown with the answer.  
Omission of essential working will result in loss of marks.  
The total of the marks for this paper is 50.

The use of an approved scientific calculator is expected, where appropriate.  
If the degree of accuracy is not specified in the question, and if the answer is not exact, give the answer to three significant figures. Give answers in degrees to one decimal place.  
For  $\pi$ , use either your calculator value or 3.142.

**For Examiner's Use**

--

This document consists of 13 printed pages and 1 blank page.

[Turn Over

- 1 (a) Factorise  $2x^2 + 7x + 5$ .

$$(2x+5)(x+1) \quad [\text{B1}]$$

Answer ..... [1]

- (b) Hence, deduce two factors of 20705.

$20705 = 20000 + 700 + 5$	
Take $x = 100$ ,	$= 2(100)^2 + 7(100) + 5$
	$= [2(100) + 5](100 + 1) \quad [\text{M1} - \text{knowing } x = 100]$
	$= 205 \times 101$
The two factors are 205 and 101.	$[\text{A1} - \text{Both correct}]$

Answer ..... and ..... [2]

- 2 (a) Solve the inequality  $\frac{1}{5}(x+2) \geq x-9$ .

$\frac{1}{5}(x+2) \geq x-9$	
$0.2x + 0.4 \geq x - 9$	
$-0.8x \geq -9.4$	$[\text{M1} - \text{o.e.}]$
$x \leq 11.75$	$[\text{A1}]$

Answer ..... [2]

- (b) Two of the sides of a triangle are 14 cm and 8 cm and the third side has a length of  $p$  cm where  $p$  is an integer. Write down an inequality that must be satisfied by  $p$ .

$6 < p < 22 \quad \text{or} \quad 7 \leq p \leq 21$
$[\text{B1} - \text{correct minimum and inequality sign}]$
$[\text{B1} - \text{correct maximum and inequality sign}]$

Answer ..... [2]

3

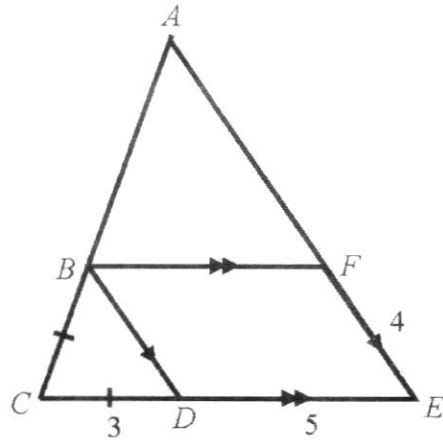

In the diagram,  $BDEF$  is a parallelogram,  $BC = CD = 3$  m,  $DE = 5$  m and  $EF = 4$  m. Given that triangle  $BCD$  is similar to triangle  $ACE$ , find the value of  $BA + AF$ .

$$\frac{BA + AF + 2(3) + 4 + 5}{2(3) + 4} = \frac{3 + 5}{3} \quad [\text{M1} - \text{accept other methods, eg find } AF]$$

$$BA + AF = 11\frac{2}{3} \text{ m} \quad [\text{A1}]$$

Answer ..... m [2]

4

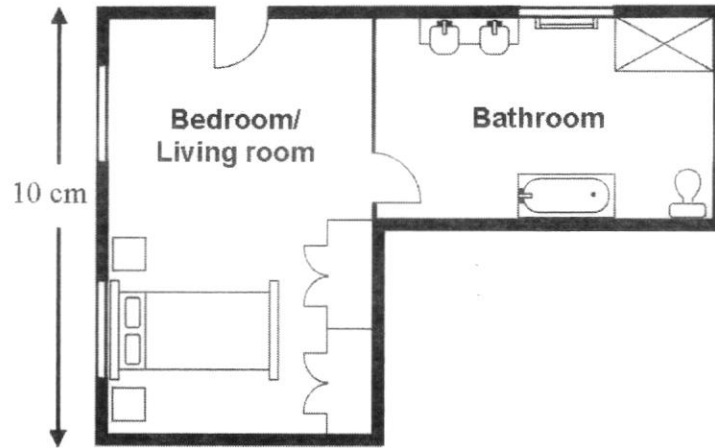

The diagram shows the floor plan of a studio apartment. On the plan, the length of the bedroom/living room is 10 cm long and the area of the bathroom is  $30 \text{ cm}^2$ . The actual length of the bedroom/living room is 5 m.

Find

(a) the scale of the floor plan,

$\begin{aligned} \text{Scale of floor plan} &= 10 \text{ cm} : 5 \text{ m} \\ &= 1 \text{ cm} : 0.5 \text{ m} \\ &= 1 : 50 \end{aligned}$	[B1]
---	------

Answer ..... [1]

(b) the actual area, in square metres, of the bathroom.

$\begin{aligned} \text{Area scale} &= 1 \text{ cm}^2 : 0.25 \text{ m}^2 \quad [\text{M1 - ecf}] \\ \text{Actual area} &= 30 \times 0.25 \\ &= 7.5 \text{ m}^2 \end{aligned}$	[A1]
--	------

Answer .....  $\text{m}^2$  [2]

5 Alvin buys a bicycle at cost price \$ $x$ .

- (a) He marks up the price of the bicycle to make a 60% profit. He then sells the bicycle to his friend at a discount of 40% on the marked-up price.  
Does Alvin make a profit, loss or break even? Explain your answer.

*Answer*

$$\begin{aligned} \text{Selling price} &= \frac{60}{100} \times \frac{160}{100} \times x && \text{[M1]} \\ &= 0.96x \\ \text{Since } 0.96x < x, &\text{ Alvin makes a loss} && \text{[A1].} \end{aligned}$$

[2]

- (b) Alvin decides to mark up the cost price of the bicycle by  $k\%$  such that he makes a profit when he offers 45% discount on the new marked price.  
Find the minimum value of  $k$  such that  $k$  is an integer. Show your workings clearly.

$$\begin{aligned} \frac{55}{100} \times \frac{100+k}{100} \times x &> x && \text{[M1 - accept equal sign, o.e.]} \\ k &> 81\frac{9}{11}\% \\ \text{Minimum } k &= 82\% && \text{[A1]} \end{aligned}$$

*Answer* ..... % [2]

- 6 When typing a report, Ben records the number of errors he made on each page of the report in the table as shown below.

Number of errors	0	1	2	3	4	5	6
Number of pages	1	3	10	$x$	4	3	2

- (a) Write down the least possible value of  $x$  if the median is 3.

Answer  $x = \boxed{6}$  [B1] [1]

- (b) Write down the greatest possible value of  $x$  if the mode is 2.

Answer  $x = \boxed{9}$  [B1] [1]

- (c) Given that the mean number of errors Ben made is 2.88, find the value of  $x$ .

$\frac{1(0) + 3(1) + 10(2) + x(3) + 4(4) + 3(5) + 2(6)}{1 + 3 + 10 + x + 4 + 3 + 2} = 2.88$	[M1]
$66 + 3x = 66.24 + 2.88x$	
$0.12x = 0.24$	
$x = 2$	[A1]

Answer  $x = \dots\dots\dots$  [2]

7 (a) Simplify  $\frac{2x^2}{7y} \div \frac{4x^2}{21y^2} \times \frac{8y}{3x}$ .

$\frac{2x^2}{7y} \div \frac{4x^2}{21y^2} \times \frac{8y}{3x} = \frac{2x^2}{7y} \times \frac{21y^2}{4x^2} \times \frac{8y}{3x}$	[M1]
$= \frac{4y^2}{x}$	[A1]

Answer ..... [2]

(b) Express as a single fraction in its simplest form

$$\frac{4}{x-3} - \frac{x+5}{x^2-7x+12}$$

$\frac{4}{x-3} - \frac{x+5}{x^2-7x+12} = \frac{4}{x-3} - \frac{x+5}{(x-3)(x-4)}$	[M1 - factorisation]
$= \frac{4(x-4) - (x+5)}{(x-3)(x-4)}$	[M1 - single fraction]
$= \frac{4x-16-x-5}{(x-3)(x-4)}$	
$\therefore = \frac{3x-21}{(x-3)(x-4)} \text{ or } = \frac{3(x-7)}{(x-3)(x-4)}$	[A1]

Answer ..... [3]

- 8 In a competition, Kayden walks at an average speed of  $(x+1)$  km/h for  $2x$  hours and cycles at an average speed of  $2(2x-3)$  km/h for  $(x+3)$  hours.

(a) Write down an expression, in terms of  $x$ , for the distance he walks.

Answer .....  $2x(x+1)$  [B1] km [1]

(b) Write down an expression, in terms of  $x$ , for the distance he cycles.

Answer .....  $2(2x-3)(x+3)$  [B1] km [1]

(c) Given that Kayden covers a distance of 172 km, write down an equation, in terms of  $x$ , and show that it reduces to

$$3x^2 + 4x - 95 = 0.$$

Answer

$2x(x+1) + 2(2x-3)(x+3) = 172$	[M1 - ecf]	
$2x^2 + 2x + 4x^2 + 12x - 6x - 18 - 172 = 0$	[M1 - ecf; expansion]	
$6x^2 + 8x - 190 = 0$	}	
$3x^2 + 4x - 95 = 0$ (shown)	}	[A1]

[3]

(d) Solve the equation  $3x^2 + 4x - 95 = 0$ .

$3x^2 + 4x - 95 = 0$	
$(x-5)(3x+19) = 0$	[M1]
$x = 5$ or $x = -\frac{19}{3}$	[A1]

Answer  $x = \dots\dots\dots$  or  $\dots\dots\dots$  [2]

(e) Hence, find the time taken Kayden takes to complete the competition.

Time taken = $2(5) + (5+3)$	
$= 18$ h	[B1]

Answer ..... h [1]

- 9 The variables  $x$  and  $y$  are connected by the equation  $y = -5x + x^2 - 2$ .  
Some corresponding values of  $x$  and  $y$  are given in the following table.

$x$	-1	0	1	2	3	5
$y$	$p$	-2	-6	-8	-8	-2

- (a) Calculate the value of  $p$ .

4 [B1]

Answer  $p = \dots\dots\dots$  [1]

- (b) On the grid below, draw the graph of  $y = -5x + x^2 - 2$  for  $-1 \leq x \leq 5$ .

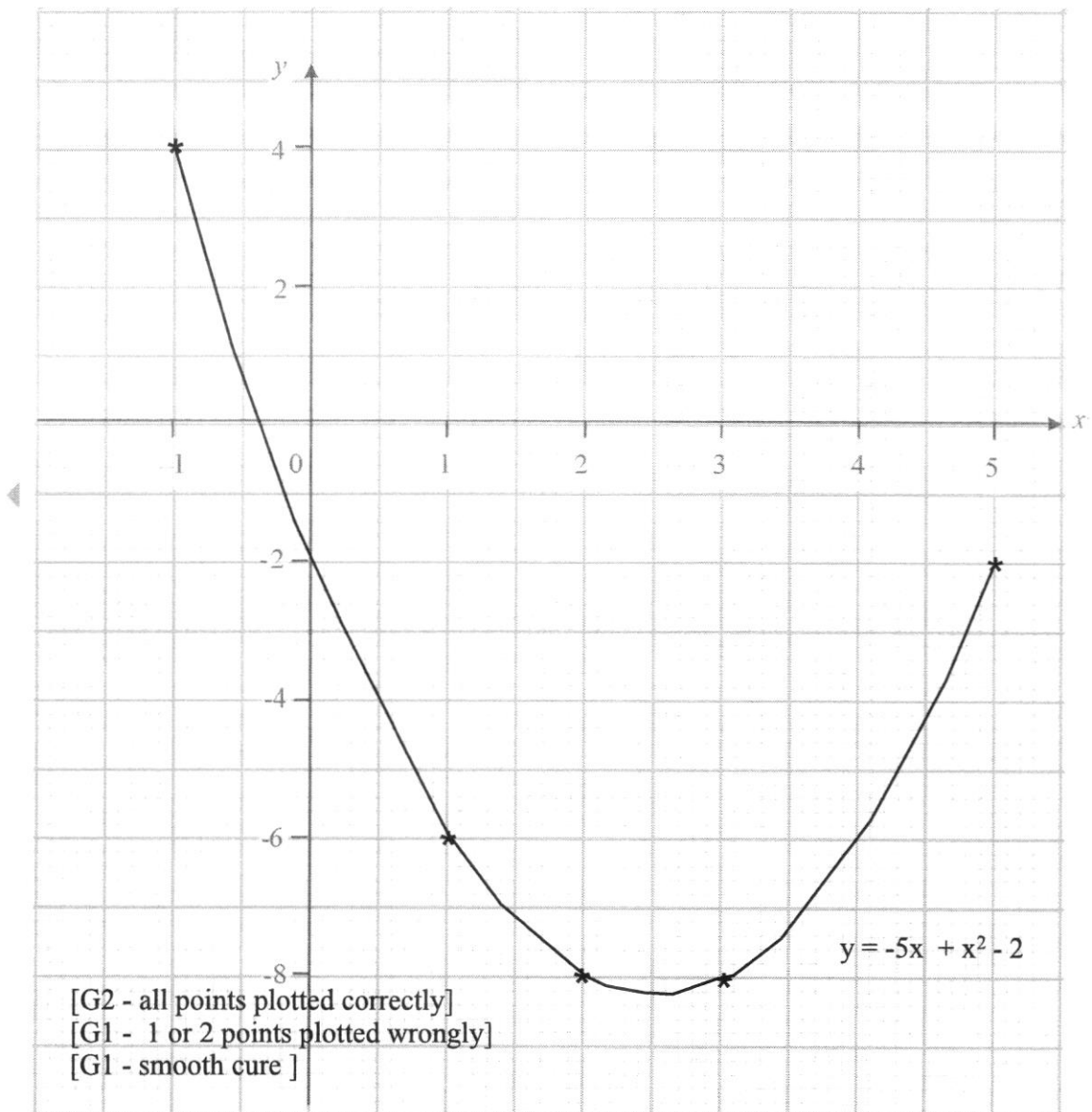

[3]

(c) Use your graph to find

(i) the minimum value of  $y$ ,

-8.2 [B1 - accept -8.1 to -8.3]

Answer ..... [1]

(ii) the equation of the line of symmetry of the curve,

$x = 2.5$  [B1]

Answer ..... [1]

(iii) the values of  $x$  when  $y = -4$ .

[B1 - accept 0.3 to 0.5]  
[B1 - accept 4.5 to 4.7]

Answer  $x = \dots\dots\dots$  and  $\dots\dots\dots$  [2]

(d) Lynn claims that she knows the value of  $y$  when  $x = 6$  by reading from the graph.  
Do you agree with her? Explain your answer.

Answer

Yes, I agree with her.

Since the curve drawn in part (b) is symmetrical and that  $y = 4$  when  $x = -1$ ,  
therefore  $y = 4$  when  $x = 6$  or  $y$  is the same value when  $x = -1$  and  $x = 6$ .

[B1 - mention curve is symmetrical]

[B1 - mention  $y = 4$  or same value when  $x = -1$  and  $6$ ]

[2]

- 10 A cylindrical container has a diameter of 50 cm. A solid cone and a solid hemisphere with a total volume of  $3670 \text{ cm}^3$  are placed in the container. The height of the cone is equal to the radius of the hemisphere. Water is poured into the container at a rate of  $4973 \text{ cm}^3/\text{s}$ .

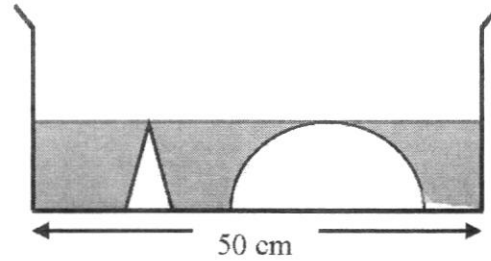

After 4 s, the water just covers the vertex of the cone.

- (a) Show that the depth of the water is 12.0 cm.

*Answer*

$$\begin{aligned} \pi(25^2)h &= (4 \cdot 4973) + 3670 \\ h &= 12.00002 \\ &= 12.0 \text{ cm (3 s.f.) (shown)} \end{aligned} \quad \left. \vphantom{\begin{aligned} \pi(25^2)h &= (4 \cdot 4973) + 3670 \\ h &= 12.00002 \\ &= 12.0 \text{ cm (3 s.f.) (shown)} \end{aligned}} \right\} \text{ [A1]}$$

[1]

- (b) Find the radius of the cone.

$$\begin{aligned} \text{Volume of cone} &= \frac{1}{3} \pi r^2 (12.00002) && \left. \vphantom{\text{Volume of cone}} \right\} \text{ [M1 – either one]} \\ \text{Volume of hemisphere} &= \frac{2}{3} \pi (12.00002)^3 \\ \frac{1}{3} \pi r^2 (12.00002) + \frac{2}{3} \pi (12.00002)^3 &= 3670 && \text{ [M1]} \\ r &= 2.0119 \\ &= 2.01 \text{ cm (3 s.f.) [A1]} \end{aligned}$$

*Answer* ..... cm [3]

- (c) Calculate the total surface area of the cone and hemisphere that is in contact with the water.

Slant height of cone = $\sqrt{2.0119^2 + 12.00002^2}$	[M1 - ecf]
= 12.167 cm	
Surface area in contact with water	
= $\pi(2.0119)(12.167) + 2\pi(12.00002)^2$	[M1 - ecf]
= 981.68	
= 982 cm <sup>2</sup> (3 s.f.)	[A1]

Answer ..... cm<sup>2</sup> [3]

---