

Visit

FreeTestPaper.com

for more papers

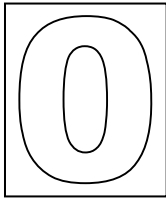

**FAJAR SECONDARY SCHOOL
2014 END-OF-YEAR EXAMINATIONS
SECONDARY 2 EXPRESS**

CANDIDATE NAME

CLASS

INDEX NUMBER

SCIENCE

2 October 2014

Paper 1 Multiple Choice

Paper 1 and 2: 2 hours

Additional Materials: OTAS Sheet

READ THESE INSTRUCTIONS FIRST

Write your name, class and index number on all the work you hand in.

Write in dark blue or black pen.

You may use pencil for any diagrams, graphs, tables or rough working.

Do not use staples, paper clips, highlighters, glue or correction fluid.

There are **thirty** questions on this paper.

For each question there are four possible answers **A, B, C** and **D**. Choose the **one** you consider correct and record your choice in **soft pencil** on the OTAS sheet.

Electronic calculators can be used in this paper.

A copy of the Periodic Table is attached on page 15 of Paper 2.

The total of the marks for this paper is 30.

The total duration for both Science Paper 1 and 2 is 2 hours.

- 1 Which of the following shows that substance **Z** is a compound?
- A When heated, **Z** changes from a solid to a liquid.
 - B When heated, **Z** produces black residue and a colourless gas.
 - C **Z** has a fixed melting point and boiling point.
 - D **Z** is a colourless and odourless gas.
- 2 Which of the following shows the chemical formula of a compound containing three different elements?
- A BaCl_2
 - B CaO
 - C $\text{CH}_3\text{CO}_2\text{Na}$
 - D $\text{Mg}(\text{OH})_2$
- 3 Four beakers with salt at the bottom are shown below. The beakers are left undisturbed for 2 hours. In which beaker would the salt dissolve the slowest?

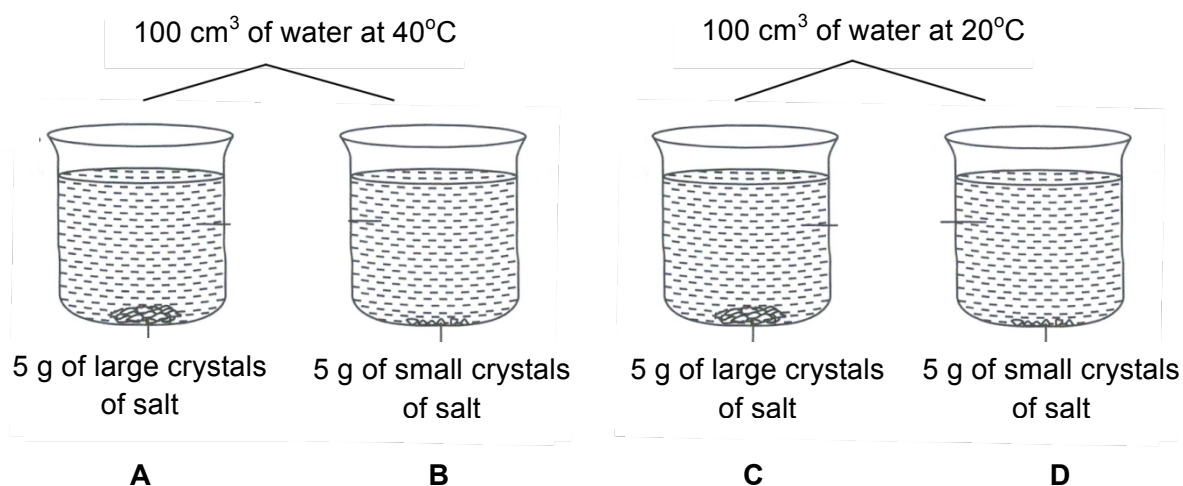

4 Which of the following are suspensions?

- I muddy water
- II orange juice
- III powdered chalk in water
- IV sports drink

- A I and II
- B I and III
- C I, II and III
- D I, III and IV

5 A sample of cows's milk from a nearby animal farm was tested for its sugar content and compared with four different types of sugars. The chromatogram is shown below.

Which sugar(s) does the cow's milk probably contain?

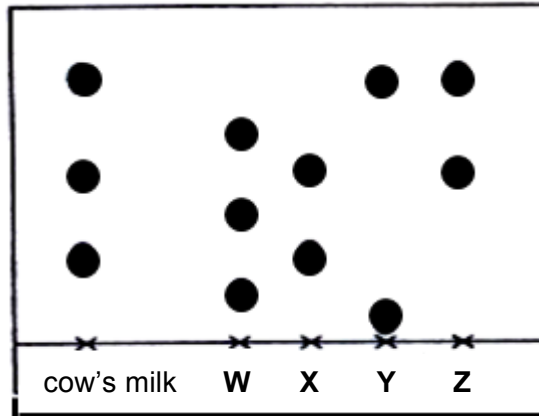

- A W only
- B X and Y
- C X and Z
- D W, Y and Z

- 6 Which of the following **cannot** be separated from a mixture by magnetic attraction?
- A aluminium bottle caps from paper rubbish
 - B nickel nails from a mixture of nickel nails and chalk
 - C scrap cobalt parts from vehicles
 - D steel paper clips from a mixture of paper clips and plastic buttons
- 7 Which of the following substance(s) can pass through the partially permeable membrane in reverse osmosis during water treatment?
- A salt
 - B water
 - C waste particles
 - D salt and waste particles
- 8 40 cm³ of liquid X is poured into 35 cm³ of liquid Y.
- If there is no loss of either liquid, why is the total volume less than 75 cm³?
- A The liquid particles attract each other, therefore reducing the volume.
 - B The particles in the liquid move slower and arrange themselves in fixed positions, so reducing the volume.
 - C The size of the particles in the two liquids differ, so the smaller particles fill in the spaces between the larger particles.
 - D The total mass of the mixture increases which compresses the liquids into a smaller volume.

- 9 The diagrams below show the particles of a substance at the various temperatures.

What are the melting point and boiling point of this substance?

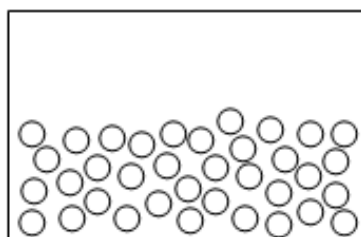

at -125°C

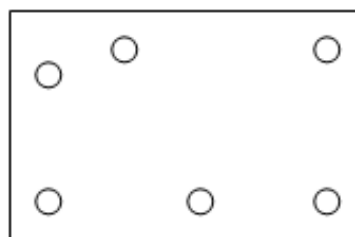

at -54°C

	melting point / $^{\circ}\text{C}$	boiling point / $^{\circ}\text{C}$
A	-187	-100
B	-180	0
C	-120	-56
D	150	238

- 10 A substance was described to change from “a state in which its particles are very closely packed and able to vibrate” to “a state in which its particles are widely spaced and able to move freely”.

What is the name of this process?

- A** condensation
- B** evaporation
- C** freezing
- D** sublimation

- 11 A caffeine molecule is represented by $\text{C}_8\text{H}_{10}\text{O}_2\text{N}_4$.

Which of the following statements is **not** true?

- A** It consists of 4 different types of atoms.
- B** It consists of hydrogen, carbon, oxygen and nitrogen.
- C** There are 24 atoms in one caffeine molecule.
- D** There are 24 atoms of carbon in two molecules of caffeine.

12 During a chemical reaction, an atom becomes a negative ion.

What happens to the number of each sub-atomic particle?

	number of protons	number of neutrons	number of electrons
A	decreases	remains unchanged	increases
B	remains unchanged	increases	decreases
C	remains unchanged	remains unchanged	decreases
D	remains unchanged	remains unchanged	increases

13 Which of the following does electricity **not** have an effect on?

- A** contraction of a bimetallic strip
- B** decomposing water
- C** heating up a stove
- D** operating an electromagnet

14 When sulfur burns in air, it forms sulfur dioxide.

Which of the following terms can be used to describe this reaction?

- I** combustion
- II** neutralisation
- III** oxidation
- IV** thermal decomposition

- A** I and III
- B** I, III and IV
- C** II and III
- D** II and IV

15 Excess acid in the stomach can cause indigestion that can be cured by an indigestion tablet.

What could the tablet contain to reduce the acidity?

- A acidic substance
- B alkaline substance
- C neutral substance
- D Universal Indicator

16 Which of the following is a function of the heart?

- A to obtain oxygen for the body
- B to pump blood around the body
- C to remove carbon dioxide from the body
- D to store oxygen and carbon dioxide

17 The potato strip in the diagram below is placed in a beaker of water.

Which of the following diagrams best shows the appearance of this potato strip after some time?

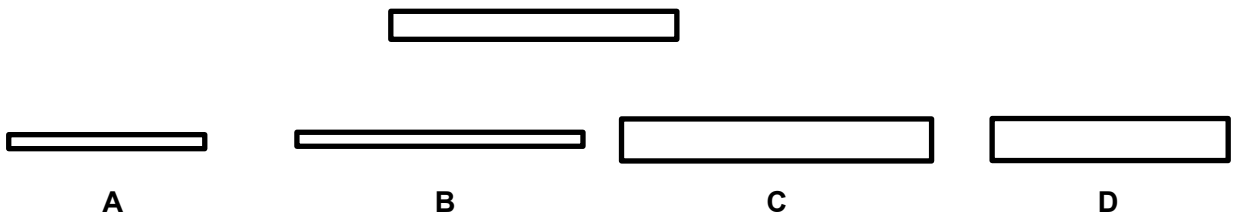

- 18 Rachel carried out an experiment on diffusion using the apparatus shown in the diagram below.

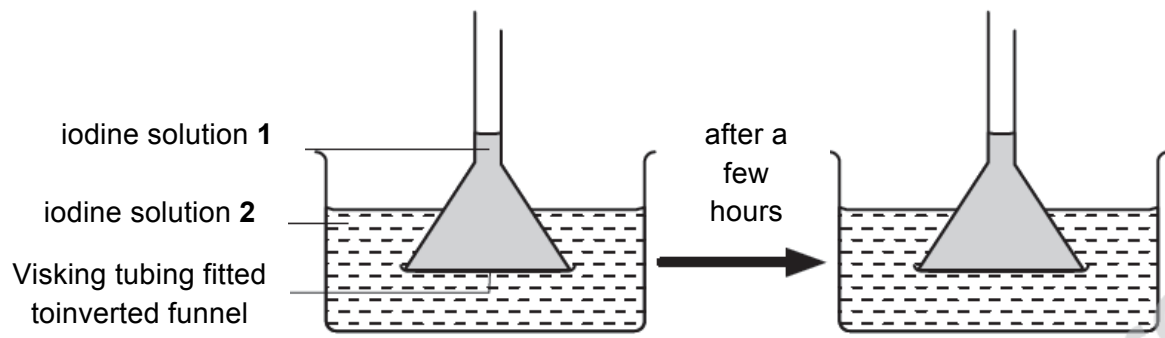

Why was there no change in the level of iodine solution 1?

- A Iodine molecules are too large to move through the Visking tubing.
 - B The concentrations of the two iodine solutions are different.
 - C The concentrations of the two iodine solutions are the same.
 - D The Visking tubing is not a partially permeable membrane.
- 19 Which of the following statements is true?
- A All arteries carry blood towards the heart.
 - B Blood vessels consist of arteries, veins and capillaries.
 - C The circulatory system only carries food around the body.
 - D The left side of the heart carries deoxygenated blood.
- 20 In human reproduction, where is the site of fertilisation?

- A cervix
- B oviduct
- C uterus
- D vagina

21 The diagram below shows the male reproductive system.

Which part produces a fluid that provides nutrients for sperms?

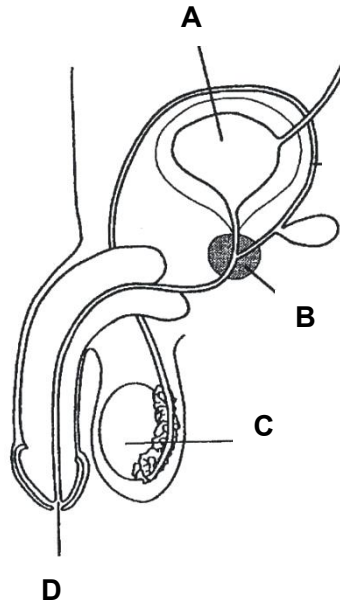

22 When a piece of metal is heated, which physical quantity increases?

- A density
- B mass
- C volume
- D weight

23 The four bowls below contain hot soup. The size and shape of the bowls are identical and each contains the same volume of soup at the same initial temperature.

After some time, which bowl of soup will be the coolest?



black plastic bowl

A



white plastic bowl

B



black plastic bowl
with cover

C



white plastic bowl
with cover

D

24 What is the best explanation of why a metal door knob feels cold to touch?

- A It conducts heat energy from the hand quickly.
- B It loses heat to the hand quickly.
- C It has a shiny surface.
- D It is a good absorber of heat energy.

25 In which of the following circuits will the voltmeter show a correct reading of the potential difference across the lamp?

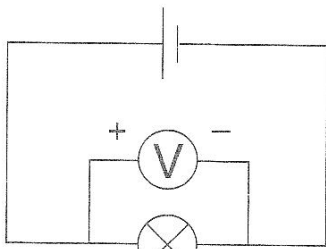

A

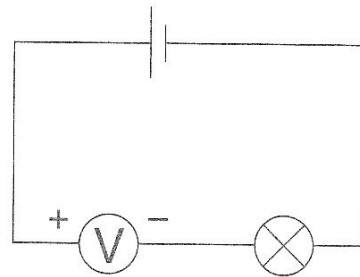

B

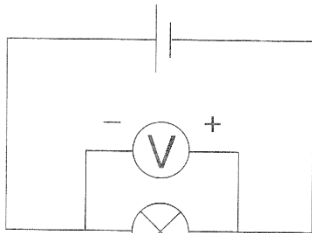

C

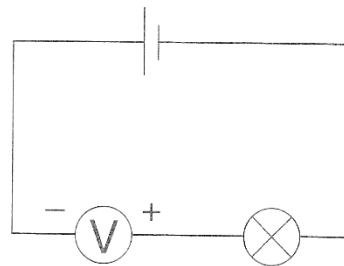

D

26 Which of the following is an example of using electricity in a safe manner?

- A Charging a hairdryer in the bathroom.
- B Overloading a power socket.
- C Touching an electrical appliance with wet hands.
- D Unplugging an electrical appliance from a socket before cleaning it.

27 Which of the following statements about a series circuit is correct?

- I As the number of components in the circuit increases, the current stays the same.
- II If one component in the circuit is damaged, the others stop working.
- III The current is the same at all points in the circuit.
- IV The maximum number of components that can be joined in the circuit is three.

- A I and III
- B I and IV
- C I, II and IV
- D II and III

28 Security mirrors in shops are usually convex rather than plane.

What is the reason for this?

- A Convex mirrors allow a wider area to be seen.
- B Images in convex mirrors are not laterally inverted.
- C The images in convex mirrors are inverted.
- D The images in convex mirrors are smaller than in plane mirrors.

- 29 The diagram shows the path of a ray of light travelling towards and into a pool of water. Four angles, **P**, **Q**, **R** and **S** are labelled.

What are the angles of incidence and refraction?

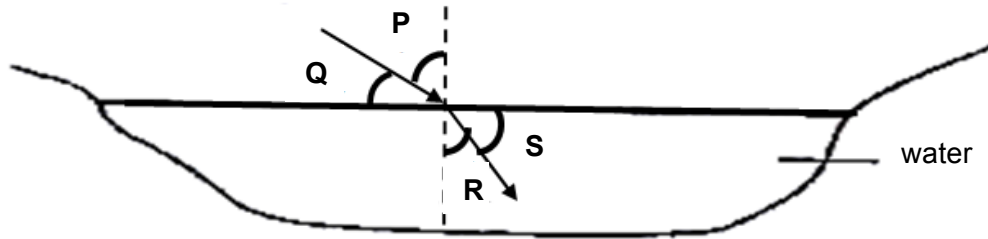

	angle of incidence	angle of refraction
A	P	R
B	Q	R
C	P	S
D	Q	S

- 30 The figure below shows a ray of light from a small lamp striking a plane mirror.

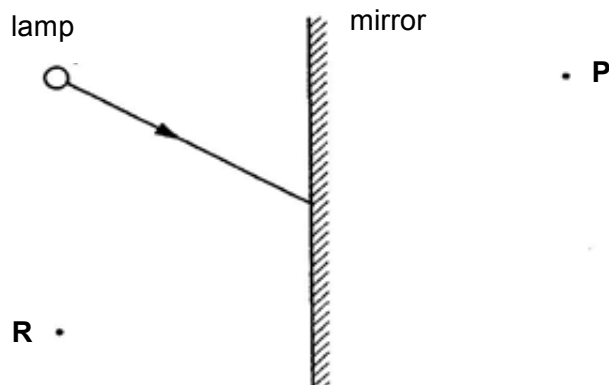

Which statement about the image formed by the mirror is correct?

- A** The image is at **P** and it is real.
- B** The image is at **P** and is virtual.
- C** The image is at **R** and is real.
- D** The image is at **R** and is virtual.

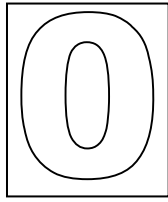

**FAJAR SECONDARY SCHOOL
2014 END-OF-YEAR EXAMINATIONS
SECONDARY 2 EXPRESS**

CANDIDATE
NAME

CLASS

INDEX
NUMBER

SCIENCE

2 October 2014

Paper 2

Paper 1 and 2: 2 hours

Candidates answer on the Question Paper

No Additional Materials are required.

READ THESE INSTRUCTIONS FIRST

Write your name, class and index number on all the work you hand in.

Write in dark blue or black pen.

You may use pencil for any diagrams, graphs, tables or rough working.

Do not use staples, paper clips, highlighters, glue or correction fluid.

Section A and B

Answer **all** questions.

Write your answers in the spaces provided on the question paper.

In calculations, you should show all steps in your working, giving you answer at each stage.

Electronic calculators can be used in this paper.

A copy of the Periodic Table is attached on page 15.

The number of marks is given in brackets [] at the end of each question or part question.

The total of the marks for this paper is 70.

The total duration for both Science Paper 1 and 2 is 2 hours.

For Examiner's Use	
Paper 1	30
Paper 2 Section A	40
Paper 2 Section B	30
Total	100

Section A [40 marks]

For
Examiner's
UseAnswer **all** questions in the spaces provided.

- 1 (a) What is the chemical symbol of the element in Group II and period 3 of the Periodic Table?

..... [1]

- (b) Name another element that has the same chemical properties as the element in (a).

..... [1]

- (c) Briefly describe the properties of a metalloid.

.....
 [1]

[Total: 3]

- 2 (a) The table below contains information about solids X and Y.

solid	information
X	X is speckled green and white. The green particles dissolves in water, but the white particles do not.
Y	Y is coloured grey. It is not attracted to a magnet. It cannot be decomposed into anything smaller.

Classify each of the solids as either an element, compound or a mixture.

- (i) Solid X is a/an [1]

- (ii) Solid Y is a/an [1]

- (b) State two differences between the properties of solutions and suspensions.

.....

 [2]

[Total: 4]

3 Study the experimental setup shown in Fig. 3.1.

For
Examiner's
Use

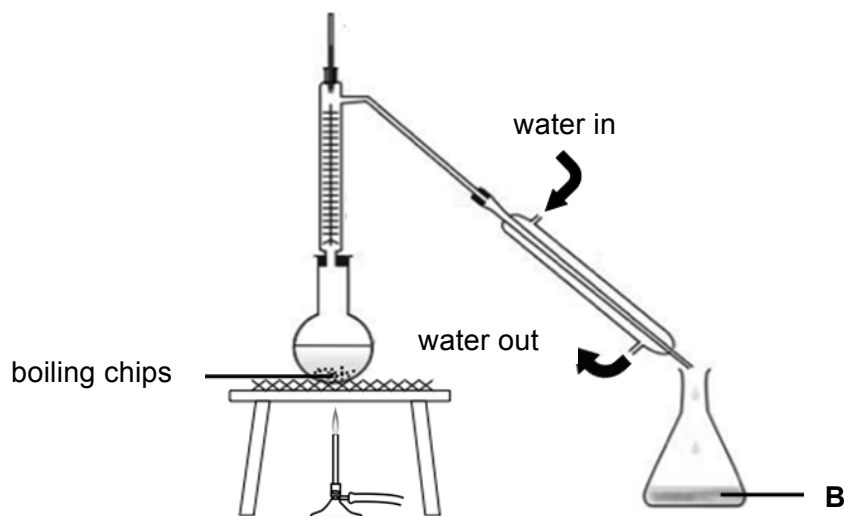

Fig. 3.1

(a) What kind of mixture can the setup above be used to separate?

..... [1]

(b) State an error in the setup.

.....
..... [1]

(c) State the purpose of the boiling chips.

..... [1]

(d) What is the general name for the liquid collected in **B**?

..... [1]

[Total: 4]

[Turn over

4 Using particle arrangement and/or movement, explain why

(a) a hot air balloon rises,

.....

[2]

(b) an iron nail cannot be compressed.

.....

[2]

[Total: 4]

5 Fig. 5.1 represents an atom.

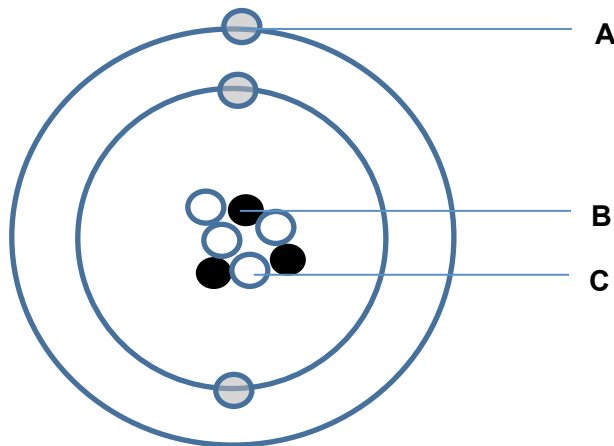

Fig. 5.1

(a) Name the sub-atomic particles of the atom.

A:

B:

C:

[3]

(b) Identify the element.

.....

[1]

[Total: 4]

- 6 A molecule of a substance is made up of calcium, carbon and element **X**. Its chemical formula is shown in the figure below.

*For
Examiner's
Use*



One molecule of this substance has a total number of 50 protons.

- (a) What is the number of protons in one atom of element **X**?

..... protons [2]

- (b) By referring to the Periodic Table, what is the nucleon number of element **X**?

..... [1]

[Total: 3]

- 7 For each of the following, decide whether a physical change or chemical change has taken place.

- (a) boiling of water

..... [1]

- (b) electrolysis of water

..... [1]

- (c) mixing of sand and salt

..... [1]

- (d) rusting of iron

..... [1]

[Total: 4]

8 (a) Some liquid **A** is added to a test tube containing some magnesium filings. The reaction produces a salt solution and a gas that extinguishes a lighted splint with a "pop" sound.

(i) Identify the gas produced.

..... [1]

(ii) Suggest a possible name of the liquid **A** added to the magnesium filings.

..... [1]

(iii) Write down the word equation for the reaction above, using answers from (i) and (ii).

..... [1]

(b) Liquid **A** was then added to some eggshells which contain calcium carbonate. A gas is produced. How would you test the presence of this gas?

.....
..... [1]

[Total: 4]

9 Name two processes that allow water and dissolved mineral salts to be absorbed by the root hair cells.

.....
..... [2]

[Total: 2]

10 (a) How is heat transferred from the sun to vehicles?

..... [1]

(b) Fig. 10.1 shows an engine of a motorcycle.

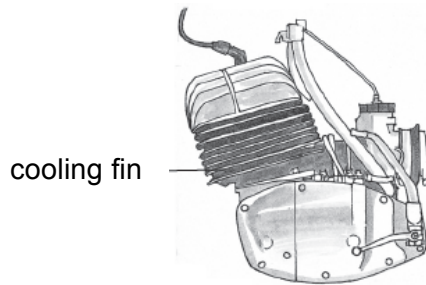

Fig. 10.1

(i) Why is the engine black?

..... [1]

(ii) Explain how the cooling fins help the engine to cool more quickly than an engine without fins.

..... [1]

[Total: 3]

11 (a) Fig. 11.1 shows a man trying to catch a fish.



Fig. 11.1

In Fig. 11.1,

(i) draw the position of the image of the fish. [1]

(ii) draw a single ray diagram to show how the boy views the fish from his position. [2]

(b) Write down how "POLICE" would be printed on police vehicles so that other motorists would be able to read it correctly.

..... [1]

(c) How are shadows formed?

..... [1]

[Total: 5]

Section B [30 marks]For
Examiner's
UseAnswer **all** questions in the spaces provided.

- 12 (a)** Xue Li had stained her clothes during lunchtime. Her friends recommended three different brands of detergent to remove her stains. She found out that the effectiveness of a detergent in removing stains is related to its solubility in water. She decided to carry out an investigation. The results of her investigation are found in Table 12.1.

brand of detergent	brand A		brand B		brand C	
temperature of water / °C	20	50	20	50	20	50
mass of detergent dissolved in water / g	1.7	30.2	1.2	3.0	5	17.6

Table 12.1

From the information in Table 12.1,

- (i) give an example to show how the temperature of water affects the solubility of the detergents.

.....

.....

.....

.....

[2]

- (ii) which brand of detergent should Xue Li use to remove her stain and at which temperature should she wash her clothes in?

.....

[2]

- (b) People with sensitive skin may develop rashes from undissolved detergent on their clothes. Which detergent should Xue Li avoid to wash her baby brother's clothes if he has sensitive skin?

.....

[1]

[Turn over

(c) How is solubility different from rate of dissolving?

.....
.....
.....
.....

[2]

(d) Gopal wants to separate a mixture of iron filings, chalk and salt. List the step he should take.

.....
.....
.....
.....
.....

[3]

[Total: 10]

13 (a) (i) Name one sexually transmitted infection.

..... [1]

(ii) State one way to prevent the spread of STIs.

..... [1]

(b) Fig. 13.1 below gives information about the 28-day menstrual cycle.

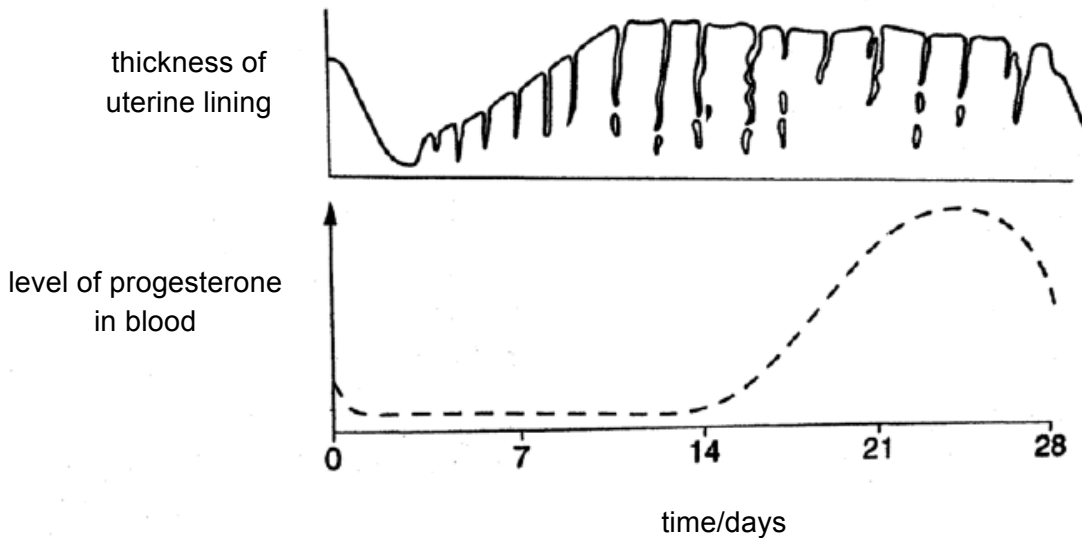

Fig. 13.1

(i) Name another female sex hormone **not** shown in Fig. 13.1.

..... [1]

(ii) Using Fig. 13.1 and your answer in (b)(i), explain the changes in the uterine lining from day 1 to 28 if fertilisation occurs.

.....

 [3]

(c) If a woman's first day of menstruation was 10 September, which date would ovulation most likely occur?

..... [1]

(d) State one structural adaptation of each of the following that allows it to perform its function.

(i) red blood cell

.....
.....

[1]

(ii) artery

.....
.....

[1]

(iii) capillary

.....
.....

[1]

[Total: 10]

14 (a) Name the SI unit for resistance.

..... [1]

For
Examiner's
Use

(b) The following circuit shows two resistors connected to a 12 V power supply and some resistors.

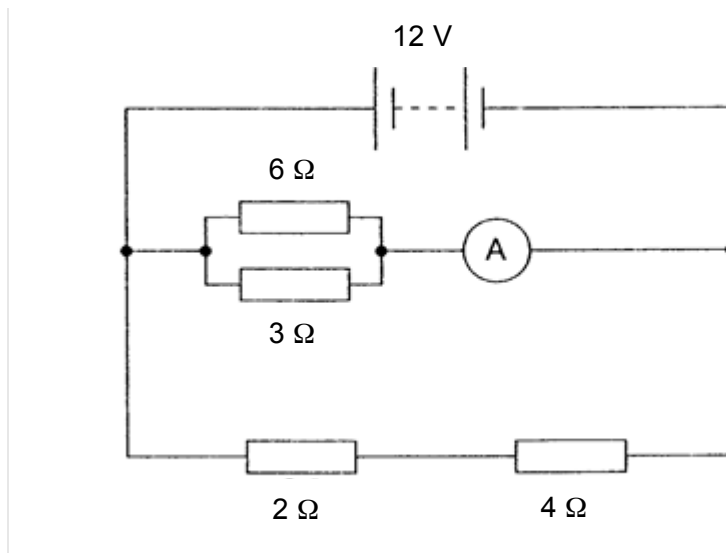

(i) Calculate the combined resistance of the 2 Ω and 4 Ω resistors in series.

resistance = Ω [1]

(ii) Calculate the combined resistance of 3 Ω and 6 Ω resistors in parallel.

resistance = Ω [2]

[Turn over

(iii) Calculate the effective resistance of the circuit.

resistance = Ω [2]

(iv) Calculate the current passing through the ammeter.

current = A [2]

(c) An air conditioner has a power rating of 1.2 kW. If each unit costs \$0.24, how much would it cost to switch it on for 8 hours?

cost = \$..... [2]

[Total: 10]

The Periodic Table of the Elements

		Group											
I	II	III	IV	V	VI	VII	0						
7 Li lithium 3	9 Be beryllium 4	11 B boron 5	12 C carbon 6	14 N nitrogen 7	16 O oxygen 8	19 F fluorine 9	20 Ne neon 10						
23 Na sodium 11	24 Mg magnesium 12	27 Al aluminium 13	28 Si silicon 14	31 P phosphorus 15	32 S sulfur 16	35.5 Cl chlorine 17	40 Ar argon 18						
39 K potassium 19	40 Ca calcium 20	48 Ti titanium 22	45 Sc scandium 21	55 Mn manganese 25	59 Co cobalt 27	64 Cu copper 29	65 Zn zinc 30	70 Ga gallium 31	73 Ge germanium 32	75 As arsenic 33	79 Se selenium 34	80 Br bromine 35	84 Kr krypton 36
85 Rb rubidium 37	88 Sr strontium 38	91 Zr zirconium 40	89 Y yttrium 39	101 Ru ruthenium 44	103 Rh rhodium 45	108 Ag silver 47	112 Cd cadmium 48	115 In indium 49	119 Sn tin 50	122 Sb antimony 51	128 Te tellurium 52	127 I iodine 53	131 Xe xenon 54
133 Cs caesium 55	137 Ba barium 56	178 Hf hafnium 72	139 La lanthanum 57	190 Os osmium 76	192 Ir iridium 77	197 Au gold 79	201 Hg mercury 80	204 Tl thallium 81	207 Pb lead 82	209 Bi bismuth 83	210 Po polonium 84	210 At astatine 85	210 Rn radon 86
87 Fr francium	88 Ra radium	89 Ac actinium	†										

1 H hydrogen 1	2 He helium
-------------------------	-------------------

140 Ce cerium 58	141 Pr praseodymium 59	144 Nd neodymium 60	150 Sm samarium 62	152 Eu europium 63	157 Gd gadolinium 64	159 Tb terbium 65	162 Dy dysprosium 66	165 Ho holmium 67	167 Er erbium 68	169 Tm thulium 69	173 Yb ytterbium 70	175 Lu lutetium 71
232 Th thorium 90	238 Pa protactinium 91	238 U uranium 92	238 Pu plutonium 94	238 Am americium 95	238 Cm curium 96	238 Bk berkelium 97	238 Cf californium 98	238 Es einsteinium 99	238 Fm fermium 100	238 Md mendelevium 101	238 No nobelium 102	238 Lr lawrencium 103

*58-71 Lanthanoid series
†90-103 Actinoid series

Key

a	X	b
a = relative atomic mass		b = proton (atomic) number

2E Science SA2 2014 Marking Scheme

Paper 1 (30 marks)

Question No	1	2	3	4	5	6	7	8	9	10
Answer	B	D	C	C	C	A	B	C	A	D
Question No	11	12	13	14	15	16	17	18	19	20
Answer	D	D	A	A	B	B	C	C	B	B
Question No	21	22	23	24	25	26	27	28	29	30
Answer	B	C	A	A	A	D	D	A	A	B

Paper 2 Section A (40 marks)

1	(a)	Mg	[1]										
	(b)	beryllium/calcium/strontium/barium/radium <i>Do not accept if chemical symbol given.</i>	[1]										
	(c)	It has properties of both metals and non-metals.	[1]										
			[Total: 3]										
2	(a)(i)	Mixture	[1]										
	(ii)	Element	[1]										
	(b)	<table border="1"> <thead> <tr> <th>Solutions</th> <th>Suspensions</th> </tr> </thead> <tbody> <tr> <td>Homogenous</td> <td>Non-homogenous</td> </tr> <tr> <td>Light can pass through</td> <td>Light cannot pass through</td> </tr> <tr> <td>No residue after filtration</td> <td>Residue after filtration</td> </tr> <tr> <td>No particles setting at the bottom when left to stand</td> <td>Particles settle at the bottom when left to stand</td> </tr> </tbody> </table> <p>1 mark for each correct difference. <i>Any 2 differences.</i></p>	Solutions	Suspensions	Homogenous	Non-homogenous	Light can pass through	Light cannot pass through	No residue after filtration	Residue after filtration	No particles setting at the bottom when left to stand	Particles settle at the bottom when left to stand	[2]
Solutions	Suspensions												
Homogenous	Non-homogenous												
Light can pass through	Light cannot pass through												
No residue after filtration	Residue after filtration												
No particles setting at the bottom when left to stand	Particles settle at the bottom when left to stand												
			[Total: 4]										
3	(a)	Mixture of liquids with different boiling points.	[1]										
	(b)	Water flowing in and out are in wrong directions.	[1]										
	(c)	To ensure smooth boiling.	[1]										
	(d)	Distillate	[1]										
			[Total: 4]										
4	(a)	Spaces between the particles increases/Particles move further apart causing the volume to increase Density decreases causing the balloon to rise	[1] [1]										

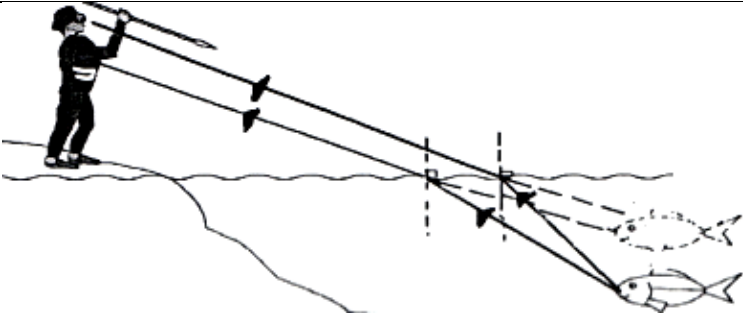
	(b)	Particles are <u>orderly/regularly arranged</u> OR <u>closely packed</u> Particles can only <u>vibrate</u> about its fixed position	[1] [1]
			[Total: 4]
5	(a)	A: electron B: proton C: neutron	[1] [1] [1]
	(b)	Li or lithium	[1]
			[Total: 4]
6	(a)	$50 - 20 - 6 = 24$ $24/3 = 8$	[1] [1]
	(b)	16	[1]
			[Total: 3]
7	(a)	Physical	[1]
	(b)	Chemical	[1]
	(c)	Physical	[1]
	(d)	Chemical	[1]
			[Total: 4]
8	(a)(i)	Hydrogen	[1]
	(ii)	Nitric acid/sulfuric acid/hydrochloric acid/ethanoic acid <i>Any other acid.</i>	[1]
	(iii)	<i>Nitric acid + magnesium → magnesium nitrate + hydrogen</i> <i>Word equation depends on acid in (b).</i>	[1]
	(b)	Pass it through limewater. There will be a <u>white precipitate/limewater turns chalky</u> in the presence of carbon dioxide. <i>Need both points to get the mark.</i>	[1]
			[Total: 4]
9	Active transport/osmosis/diffusion <i>Any 2. 1 mark each.</i>		[2]
			[Total: 2]
10	(a)	Radiation	[1]
	(b)(i)	Black is a good emitter of heat.	[1]
	(ii)	The fins provide a large surface area for heat to emit from.	[1]
			[Total: 3]
11			
	(a)(i)	Image of fish in correct position	[1]
	(ii)	Rays from fish to boy (solid lines)	[1] [1]

		Rays from image of fish (dotted lines)	
	(b)	POLICE	[1]
	(c)	Shadows are formed when the path of <u>light</u> is blocked.	[1]
			[Total: 5]

Paper 2 Section B (30 marks)

12	(a)(i)	A <u>higher temperature</u> , the <u>greater the solubility</u> of the solvent/the more soluble the solvent is.	[1]
		e.g. brand A, only 17g dissolve in 20 °C but 30.2g dissolve in 50 °C. <i>Accept similar examples for brand B and C.</i>	[1]
	(iii)	Brand A 50°C	[1] [1]
	(b)	Brand B	[1]
	(c)	Solubility the <u>maximum amount of solute</u> dissolving in a solvent while rate of dissolving is a measure of how fast/the time taken to completely dissolve in 100 g of solvent/fixed amount of solvent at fixed temperature	[1] [1]
	(d)	Use a magnet to separate the iron filings from the mixture.	[1]
		<u>Dissolve</u> the salt in water and <u>filter</u> the mixture of salt solution and chalk.	[1]
		<u>Evaporate</u> the salt solution to obtain the salt.	[1]
			[Total: 10]
13	(a)(i)	AIDS/gonorrhoea/syphilis	[1]
	(ii)	Avoid having many sexual partners. Males wear condom during sexual intercourse. Avoid sharing of needles. Sterilise instruments for acupuncture/tattooing/ear piercing etc Use disposable instruments. <i>Any 1. Accept other correct answers.</i>	[1]
	(b)(i)	Oestrogen	[1]
	(ii)	From day 1 to 4, <u>menstruation</u> occurs so <u>uterine lining</u> <u>decreases/breaks down</u> .	[1]
		From day 5 to 11, oestrogen repairs uterine lining/makes the lining thicken/more vascularised	[1]
		From day 14 to 28 <u>progesterone</u> helps to <u>maintain the thickness of</u> uterine lining to prepare for implantation.	[1]

	(c)	23 September (+/- 1 day)	[1]
	(d)(i)	Biconcave shape to <u>increase surface area</u> to volume ratio for oxygen transport OR No nucleus to <u>store more haemoglobin/transport more oxygen</u>	[1]
	(ii)	<u>Thick muscle wall</u> to <u>withstand high pressure</u> of blood	[1]
	(iii)	<u>One cell thick</u> for <u>efficient diffusion/exchange</u> of materials	[1]
			[Total: 10]
14	(a)	Ohm OR Ohm (Ω) <i>Do not accept just Ω.</i>	[1]
	(b)(i)	$2 + 4 = 6 \Omega$	[1]
	(ii)	$1/R = 1/6 + 1/3$ $= 1/2$ $R = 2 \Omega$	[1] [1]
	(iii)	$1/R = 1/6 + 1/2$ $= 2/3$ $R = 3/2 = 1.5 \Omega$	[1] [1]
	(iv)	$I = V/R$ $= 12/2$ $= 6 \text{ A}$	[1] [1]
	(c)	$1.2 \text{ kW} \times 8 \text{ h} = 9.6 \text{ kWh}$ $9.6 \text{ kWh} \times \$0.24 = \2.30	[1] [1]
			[Total: 10]