

Visit

FREETESTPAPER.com

for more papers



Website: [freetestpaper.com](http://www.freetestpaper.com)



[Facebook.com/freetestpaper](https://www.facebook.com/freetestpaper)



[Twitter.com/freetestpaper](https://www.twitter.com/freetestpaper)

NAME:

NO:

CLASS:

ADMIRALTY SECONDARY SCHOOL



MID-YEAR EXAMINATION 2019

SUBJECT : Science
 LEVEL/STREAM : Secondary 2 Express
 DATE : 15 May 2019
 TIME : 0755 h – 0955 h
 DURATION : 2 hours

Instructions to candidates:

Write your name, index number and class on the cover page.

Write in dark blue or black pen.

Do not use staples, paper clips, highlighters, glue or correction fluid.

Section A: Multiple choice questions [20 marks]

Answer all questions in the OTAS provided.

Section B: Short answer questions [40 marks]

Answer all questions. Write your answers in the spaces provided in the question paper.

Section C: Structured questions [40 marks]

Answer any four out of five questions. Write your answers in the spaces provided in the question paper.

Submit the question paper and OTAS separately.

Candidates are reminded that all quantitative answers should include appropriate units.

The use of an approved scientific calculator is expected, where appropriate.

The number of marks is given in brackets [] at the end of each question or part question.

For Examiner's Use	
Section A	/ 20
Section B	/ 40
Section C	/ 40
Total	/ 100

DO NOT TURN OVER THIS PAPER UNTIL YOU ARE TOLD TO DO SO.

Section A

Answer all questions.

- 1 The diagram below shows four pathways in which blood is transported around the body. Which pathways contain deoxygenated blood?

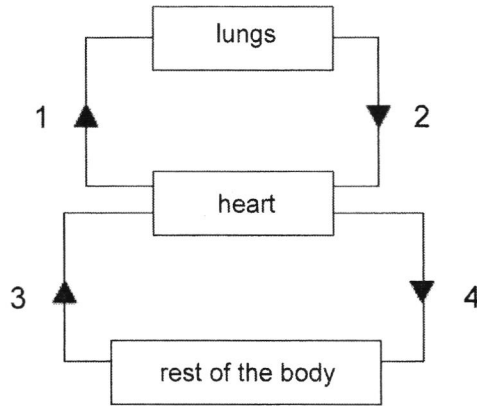

- A 1 and 3 B 1 and 4 C 2 and 3 D 2 and 4
- 2 Which of the following options is true about diffusion and osmosis?

	diffusion	osmosis
A	involve all molecules and do not require a partially permeable membrane	involve only water molecules and require a partially permeable membrane
B	involve all molecules and require a partially permeable membrane	involve only water molecules and require a partially permeable membrane
C	involve only water molecules and do not require a partially permeable membrane	involve all molecules and do not require a partially permeable membrane
D	involve only water molecules and require a partially permeable membrane	involve all molecules and do not require a partially permeable membrane

- 7 Sally sets up an electrical circuit as shown below.

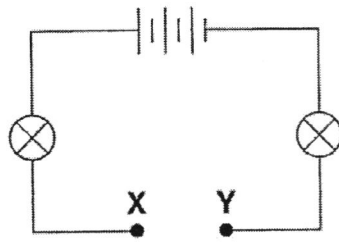

Sally wants to find out how much current is flowing through the circuit. Which of the following electrical components should she connect between X and Y?

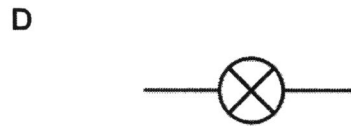
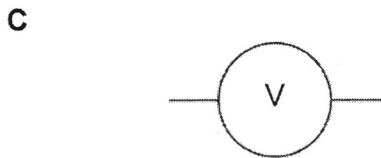
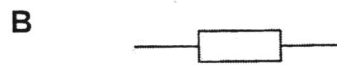
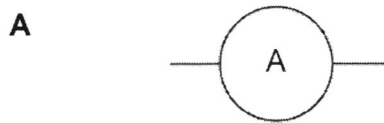

- 8 Which of the following will have at least one bulb still lighted up even if bulb X blows?

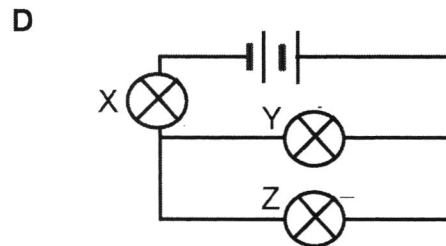
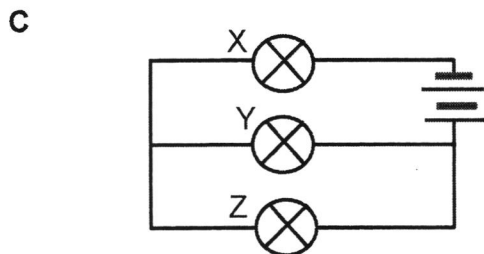
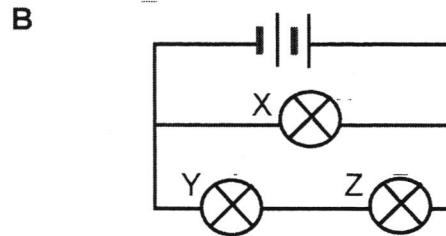
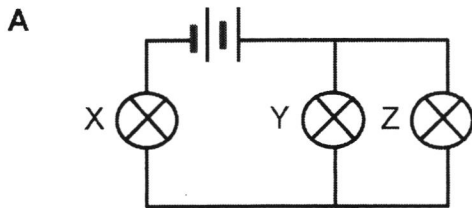

- 9 In which part of the female reproductive system does fertilisation occur?

A ovary B oviduct C uterus D vagina

10 Which of the following statements is true about the human eggs?

- A Each egg contains half the number of chromosomes compared to the body cell.
- B The egg has a cell wall to protect the egg from injury.
- C The eggs are highly mobile to increase chances of fertilisation.
- D Before puberty, under-developed eggs are released from the ovary but cannot be fertilised.

11 The diagram below shows a pregnancy that is already in the 35th week.

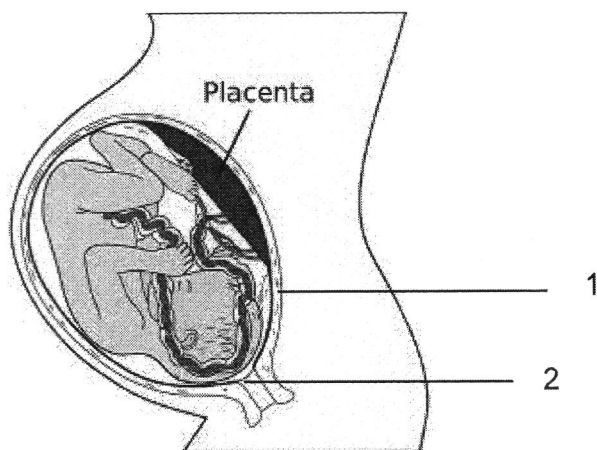

What are structures 1 and 2?

	1	2
A	ovary	vagina
B	cervix	ovary
C	uterus	cervix
D	uterus	vagina

12 Refer to the table below. Which of the following is true about whether ovulation, menstruation and sex hormones production can still occur in the female reproductive system when both fallopian tubes are cut and tied up?

	ovulation	menstruation	sex hormones production
A	✓	✓	✓
B	✓	✗	✓
C	✗	✗	✗
D	✓	✓	✗

Key:

✓ - can occur

✗ - cannot occur

13 Which of the following can still take place successfully if friction is absent?

- A bouncing a ball
- B leaning against a wall without slipping
- C lighting a match stick by striking
- D stopping a moving car

14 A brick of weight 80 N stands upright on the ground as shown. What is the pressure it exerts on the ground?

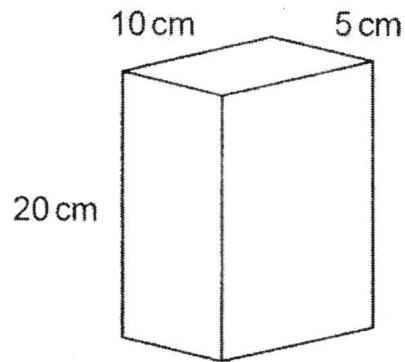

- A 0.63 N/cm^2 B 0.80 N/cm^2 C 1.60 N/cm^2 D 2.50 N/cm^2

15 The same downward force is applied to four objects resting on a horizontal surface. Which exerts the least pressure on the surface?

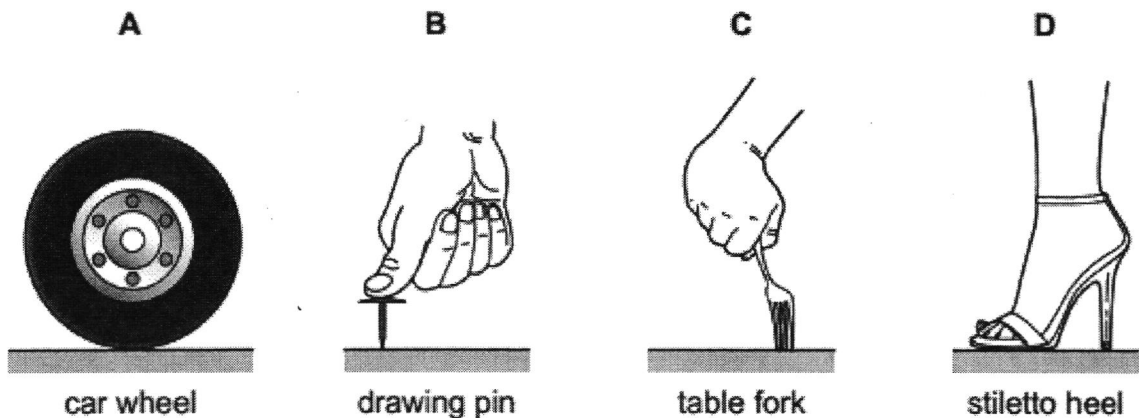

- 16 Which of the following shows a non-contact force?
- A A car driving on the road.
 B A man raising a dumbbell.
 C An athlete running on a track.
 D A magnet repelling another magnet.
- 17 James touched a metal cup and a plastic cup containing ice water. Which of the following is the correct observation and explanation?
- A The plastic cup was colder because it is less shiny.
 B The metal cup was warmer because it absorbs heat faster.
 C The metal cup was colder because it conducts heat slower than plastic.
 D The plastic cup feels warmer because it is a poor conductor of heat.
- 18 Four beakers, containing the same volume of water at the same temperature, are placed on hot metal plates. The lower surfaces of the metal plates are kept at the same temperature for 200 seconds. The plates are all of the same size but are made from four different metals.

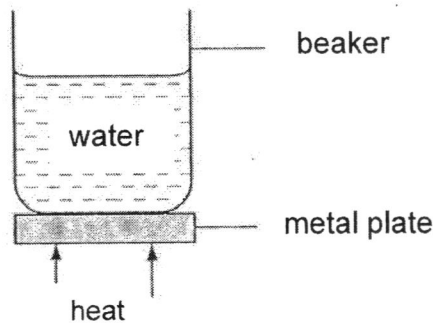

The increases in temperature of the water after 200 seconds are given below. Which metal (A, B, C or D) is the poorest conductor of heat?

metal	temperature of water after 200s ($^{\circ}\text{C}$)
A	10
B	12
C	15
D	18

19 Which comparison between conduction and convection of heat energy is correct?

	conduction	convection
A	can occur best in solids	only occurs in liquids and gas
B	can occur best in gas	only occurs in solids and liquids
C	only occurs in liquids and gas	can occur in solids
D	only occurs in solids and liquids	can occur in gas

20 Two plastic cups are placed one inside the other. Hot water is poured into the inner cup and a lid is put on top as shown.

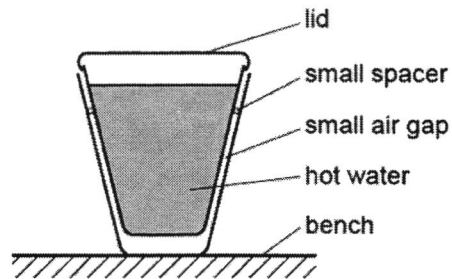

Which of the following statements is correct?

- A Heat loss by radiation is prevented by small air gap.
- B No heat passes through the sides of either cup.
- C The bench is heated by convection from the bottom of the outer cup.
- D The lid is used to reduce heat loss by convection.

Section B

Answer all questions.

- 1 (a) John uses a 2000 W kettle to boil water. The cost of electricity is 25 cents per kWh.

- (i) State what “2000 W” in (a) means.

.....
 [1]

- (ii) Calculate the energy consumed when John boils water for 15 minutes.

energy = [2]

- (iii) Calculate the total cost of electricity if John boils water for 15 minutes a day for 2 weeks.

total cost = [2]

- (b) Fig. 1.1 shows a simple circuit diagram.

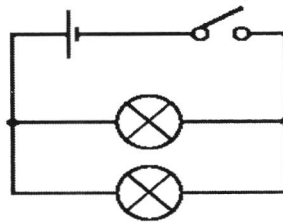

Fig. 1.1

- (i) In Fig. 1.1, draw an electrical component that will allow you to vary the brightness of both light bulbs. [1]

- (ii) Briefly describe how the electrical component you drew in (b)(i) allows you to vary the brightness of both light bulbs.

.....
 [2]

- 2 (a) Sally is diagnosed with Thrombocytopenia, which causes her platelet count to be lower than normal. Suggest a reason why it is dangerous for her to get an injury.

.....
..... [2]

- (b) Sally is also diagnosed with Neutropenia, which causes her white blood cell count to be low. Suggest a possible danger that Sally faces when she goes to crowded places. Explain your answer.

.....
..... [2]

- 3 Fig. 3.1 shows a stalk of white rose that is placed outdoors.



Fig. 3.1

- (a) Predict what would happen to the stalk of rose if it has its phloem tube removed. Explain your answer.

.....
.....
..... [2]

- (b) Explain why the petals of the rose turns blue when the stalk is placed in a solution containing blue dye.

.....
.....
..... [2]

4 Fig. 4.1 shows the male reproductive system.

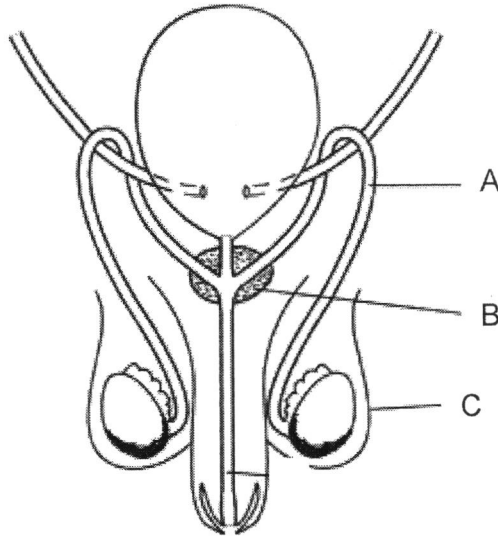

Fig. 4.1

(a) Name parts A to C and describe their functions.

A:

.....

B:

.....

C:

.....

[6]

(b) State two physical changes a boy undergoes during puberty that differs from a girl.

.....

.....

.....

[2]

- 5 A box of mass 120 kg is shown in Fig. 5.1. The area of contact with the surface of the floor is 10 cm².

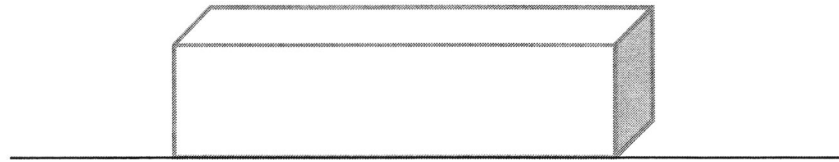

floor

Fig. 5.1

- (a) A man pushed the box and it travelled a distance of 5 km in 2 hours. Calculate the speed of the box.

speed = [1]

- (b) Calculate the total pressure exerted by the box on the floor.

pressure = [2]

- (c) Suggest a method to reduce the pressure exerted by the box on the floor. Explain your answer.

.....
 [2]

- (d) If the box moves from left to right, draw and label on Fig. 5.1 another type of force that is acting on the box. [1]

- (e) If this box is moved to outer space, what is the weight of the box? Provide a reason for your answer.

.....
 [2]

- 6 Mrs Lee is having guests over to her house for high tea. She decided to get a new teapot to host her guests. She could not decide between a tea pot with a shiny surface or a teapot with a dull black surface. Fig. 6.1 shows a teapot she intended to buy.

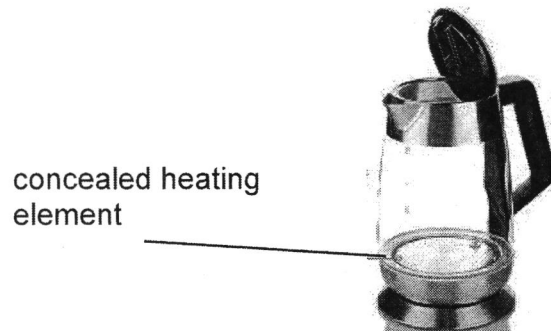

Fig. 6.1

- (a) Which tea pot should she buy if she wants to keep a pot of hot tea at a higher temperature than the surrounding for a longer period of time? Give two reasons to support your choice of teapot.

.....

.....

.....

..... [3]

Mrs Lee noticed that there is a heating element at the bottom of the teapot.

- (b) (i) On Fig. 6.2, draw arrows to show movement of water in the teapot [1] when the heating element is turned on.

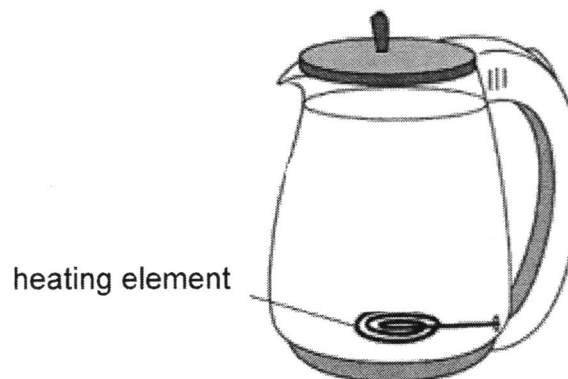

Fig. 6.2

- (ii) Explain how turning on the heating element of the teapot caused the convection currents in (b)(i).

.....

.....

.....

.....

..... [3]

- (c) Suggest another method to keep the tea hot for a longer period of time compared to using the teapot she bought in (a).

..... [1]

Section C

Answer any four out of the given five questions.

- 7 (a) Fig. 7.1 shows a simple diagram of the electrical circuit in a typical household.

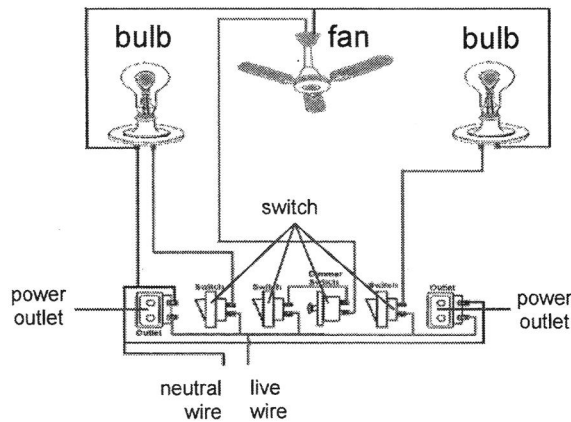

Fig. 7.1

- (i) Explain why all the electrical appliances can be switched on and off individually.

.....

.....

..... [2]

- (ii) Predict what would happen if a person accidentally touches the metal casing of a faulty light bulb in Fig. 7.1. Explain your answer.

.....

.....

.....

..... [3]

- (b) Jane has two light bulbs that look identical, but one light bulb has a higher potential difference than the other.

- (i) Suggest how Jane can identify which light bulb has a higher potential difference.

.....

.....

..... [2]

- (ii) Jane uses the light bulb and some wires to complete an electrical circuit. Predict what would happen to the brightness of the light bulb if Jane changes to thicker wires in the circuit.

.....

.....

.....

..... [3]

8 (a) Hypotension is a condition whereby the blood pressure of a person is very low, such that it takes longer for blood to flow to the organs of the body. People with hypotension normally feel dizzy and tired.

(i) Explain why blood is able to circulate continuously around our body.

.....
..... [1]

(ii) Give three reasons why it is important for blood to flow around our body.

.....
.....
.....
..... [3]

(iii) Explain why people with hypotension feel dizzy and tired.

.....
.....
..... [2]

(b) Osmoregulation is an important process in aquatic organisms to prevent the organism's fluids from being too concentrated or diluted, which can lead to death. Fig. 8.1 shows a clownfish, which lives in saltwater.

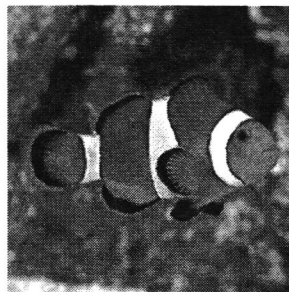

Fig. 8.1

- (i) Using the information on the previous page and your understanding of osmosis, explain why the clownfish will die if it is placed in freshwater.

.....

.....

.....

.....

..... [3]

- (ii) In the box below, draw the molecules in the clownfish after it is placed in freshwater, using ○ to represent a water molecule and ● to represent a salt particle.

Before:

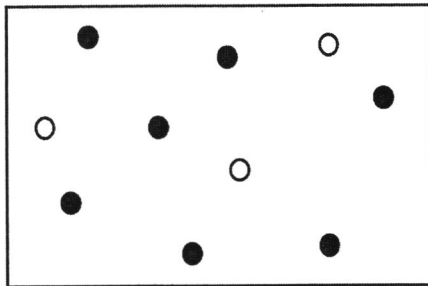

After:

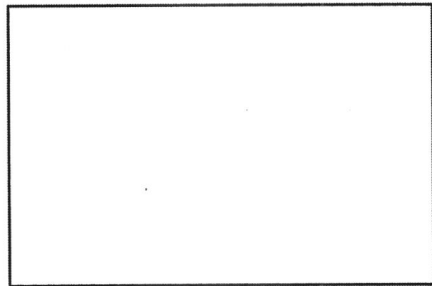

[1]

- 9 (a) Fig. 9.1 shows the main parts of an electrical grill that is used widely in fast food restaurants to grill the patties of burgers.

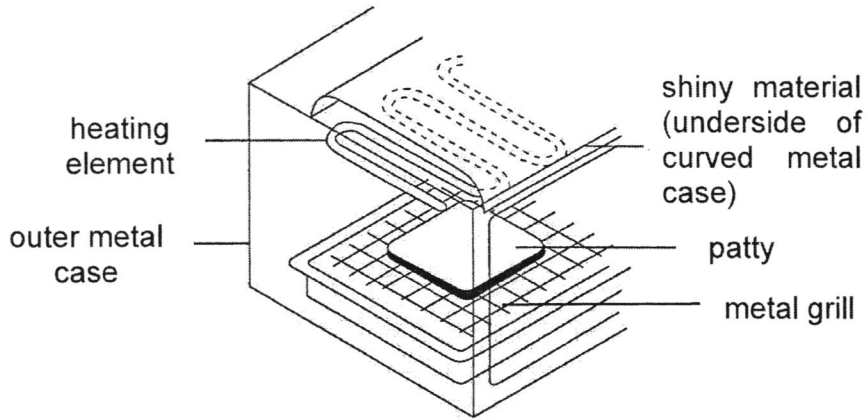

Fig. 9.1

- (i) Identify the mode of heat transfer from the grill to the patty when the patty is being grilled. Explain your answer.

.....

 [2]

- (ii) The grill has a shiny material that is between the heating element and outer case. State the purpose of the shiny material.

.....
 [2]

- (iii) Suggest how you would modify the electrical grill by changing the position of the heating element, so that the patties can be heated up at a faster rate. Explain your answer.

.....

 [3]

- (b) Describe what happens after fertilisation, leading up to the implantation of the embryo.

.....
.....
.....

- (c) A woman uses the information in this graph to avoid being pregnant. She abstains from sexual intercourse from day 5 to day 27. Give two comments on the reliability of this method of contraception. [2]

.....
.....
.....

- (d) State one way Sexually Transmitted Infections (STIs) are spread in a population and suggest one method we can use to prevent it from spreading. [2]

.....
..... [2]

- 11 A vertical uniform tube of cross-sectional area 0.25 cm^2 contains a column of liquid of length 0.124 m , as shown in Fig. 11.1.

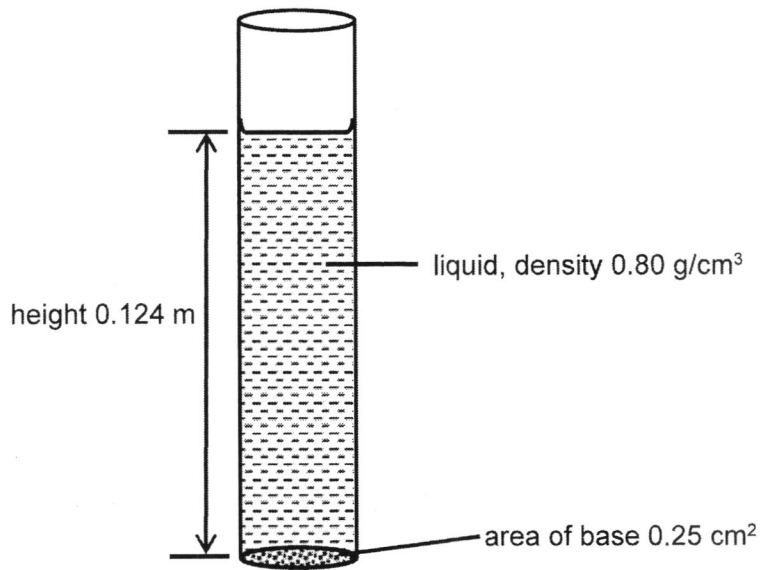

Fig. 11.1

The density of the liquid is 0.80 g/cm^3 .
 (volume of cylinder = area of base \times height; density = mass \div volume)

Calculate

- (a) the mass of liquid in the tube,

mass = [3]

- (b) the weight of liquid in the tube,

weight = [2]

- (c) the pressure on the base of the tube due to the column of liquid.

pressure = [2]

The tube was considered to be used as part of the solar panel as shown in Fig. 11.2 to heat water.

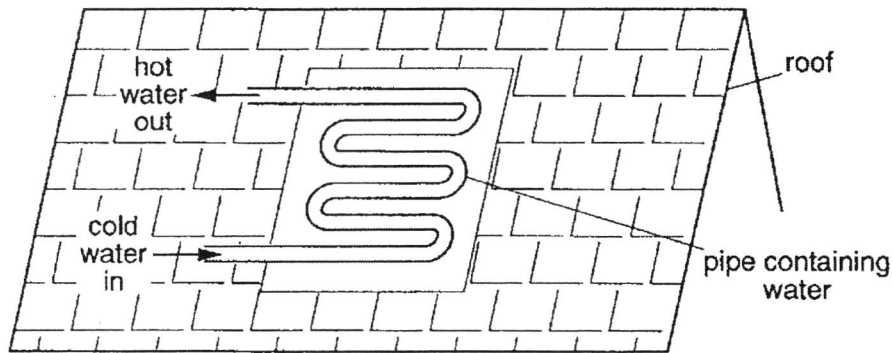

Fig. 11.2

State the process by which heat energy is transferred

- (d) (i) from the Sun to the outside of the pipe in the solar panel,

..... [1]

- (ii) from the outside of the pipe to the water inside it.

..... [1]

- (e) Circle one of the following materials that would be the most suitable for making the pipe that contains the water in Fig. 11.2, if we want to heat up the water in the pipe faster.

black plastic; white plastic; glass; black-painted copper; polished steel. [1]

END OF PAPER

Type of exam: Mid-Year-Examination 2019
 Level/Stream: 2 Express

Name of setters: Elena Thein, Jocelyn Goh
 Class(es): 2E1, 2E2, 2E3, SBB (2N2, 2N3)

SECTION A

1	2	3	4	5	6	7	8	9	10
A	A	B	C	D	C	A	B	B	A
11	12	13	14	15	16	17	18	19	20
C	A	A	C	A	D	D	A	A	D

SECTION B

Q.	Answer	Marks	Remarks
1	(a)(i) 2000 joules of electrical energy is converted to other forms of energy in one second.	[1]	
	(a)(ii) Electrical energy = power x time = 2 kW x 0.25 h [M1] = 0.5 kWh [A1]	[2]	
	(a)(iii) Total cost = (0.5 x 14) x 25 [M1] = \$1.75 [A1]	[2]	ECF Accept 175 cents
	(b)(i) Draw a variable resistor in the circuit	[1]	
	(b)(ii) The variable resistor can increase resistance , which decreases the amount of current in a circuit, making the bulbs dimmer (and vice versa).	[1] [1]	
2	(a) Since she has a low platelet count, she will not be able to clot blood as easily , therefore she may bleed excessively .	[1] [1]	
	(b) There is a higher chance of getting an infection from others as there are more people around . Since she has a low white count, she will not be able to fight infections as easily , and in crowded places.	[1] [1]	
3	(a) The rose will eventually wither and die , as the leaves will not be able to transport food to the rest of the plant .	[1] [1]	
	(b) The dye molecules will travel up the xylem and reach the flower petals by diffusion , causing the petals to turn blue.	[1] [1]	
4	(a) A sperm duct transport sperms from the testes to the urethra	[1] [1]	
	B sex glands provide nutrients for the sperms to swim	[1] [1]	

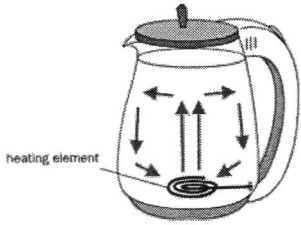
		C scrotum a bag that carries the testes so that it is at a lower body temperature for sperms production.	[1] [1]	
	(b)	Voice box deepens Chest enlarges Facial hair growth	[2]	Must be specific for males (any 2 reasonable answers)
5	(a)	Speed = Distance/ Time = 5/2 = 2.5 km/h	[1]	
	(b)	Area of contact between the box and the floor = 10 x 2 = 20 cm ² = 0.002m ² Pressure = 1200/ 0.002 = 600 000 Pa = 60 N/cm ²	[1] [1]	
	(c)	Increase in area, decrease in pressure. OR Use a lighter material so lesser force exerted	[1] [1] [1] [1]	
	(d)	(draw a frictional force in the direction of right to left)	[1]	
	(e)	No weight no pull of gravity acting on the object	[1] [1]	
6	(a)	Tea pot with shiny surface. Dull black surface is a <u>good radiator of heat</u> so tea pot will cool down faster. Shiny surface is a <u>good reflector of heat</u> which reflects the heat back to the teapot thus maintaining a higher temp.	[1] [1] [1]	
	(bi)		[1]	
	(bii)	When heated, the water around the heating element heats up, becomes <u>less dense and rises</u> . cold water <u>more dense sinks</u> from the top <u>convection current</u> is set up and the whole kettle of water heat up quickly.	[1] [1] [1]	
	(c)	Put into a vacuum flask Wrapped teapot with a cloth Immersed tea pot in hot water changing the hot water occasionally	[1]	Any one reasonable answer

SECTION C

Q.	Answer	Marks	Remarks
7	(a)(i) The electrical appliances have individual switches , which allows current to be supplied and cut off which the switch is pressed / which creates an open or closed circuit to allow or prevent current from flowing.	[1] [1]	
	(a)(ii) The person will get an electric shock/be electrocuted , because there is no earth wire to help to direct excess current to the ground.	[1] [1] [1]	
	(b)(i) Jane should use a voltmeter/multimeter to measure the potential difference of each of the light bulbs. The light bulb that has a higher reading/higher voltage has a higher potential difference.	[1] [1]	
	(b)(i) The light bulbs will become brighter because there is lesser resistance in the circuit, so there will be more current flowing.	[1] [1] [1]	
8	(a)(i) The heart pumps blood continuously around our body.	[1]	
	(a)(ii) <ul style="list-style-type: none"> • To transport digested food from the small intestine to other parts of the body • To remove carbon dioxide and other waste substances produced in body cells • To transport other substances such as hormones 	[1] [1] [1]	
	(a)(iii) As it takes longer for blood to flow to the organs of the body, not enough oxygen (and nutrients) are being transported to the vital organs to produce energy (during respiration), hence the person will feel dizzy and tired.	[1] [1]	
	(b)(i) There is a higher concentration of water molecules in the freshwater compared to in the clownfish. Water molecules move from the freshwater into the clownfish across a partially permeable membrane by osmosis, Causing (the cells in) the clownfish to swell and burst.	[1] [1] [1]	

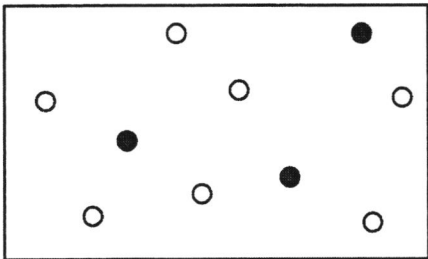
	(b)(ii)	After: 	[1]	Just need to show that there are more water molecules than salt molecules after the goldfish is placed in saltwater.
9	(a)(i)	Conduction Heat is transferred from the metal grill to the patty without involving any movement of the material (metal grill)	[1] [1]	
	(a)(ii)	The shiny material will be able to reflect the heat back to the grill through radiation.	[1] [1]	
	(a)(iii)	Bottom of the grill. This will create a convection current so that heat transfer is faster. The heating element will heat the air and cause it to rise, cooled air from the top of the grill sinks to take its place. OR Bottom of the grill. The heating element will be nearer to the patty which will allow the patty to be cooked faster through radiation	[1] [1] [1] [1] [1] [1]	
	(b)	White lunch box. It is a good reflector/poor absorber of heat and will not become as hot as the black lunch box.	[1] [1]	
	(c)	- Keeping the house warm in winter - Ironing a shirt - Drying clothes - Providing light during campfires - Using a heatpack to keep ourselves warm	[1]	Accept any reasonable answer Reject: if student just writes "keep warm", as they did not state HOW
10	(a)	Day 1-5, <u>no ovum</u> released so low chance of pregnancy Day 6-13, chance of pregnancy increases as there is a <u>possibility that an egg might be released</u> . <u>Ovulation occurs</u> around day 14 so chance of fertilisation is high so high chance of pregnancy Ovum survives for 1-2 days so after day 16, chance of fertilisation is low as <u>ovum may not be present</u> .	[1] [1] [1] [1]	
	(b)	Upon fertilisation, the <u>zygote will divide continuously to form a ball of cells/ embryo</u> Embryo will move from fallopian tube to the uterus to be implanted into the <u>lining of the uterus</u>	[1] [1]	

	(c)	Not reliable as the menstrual cycle can <u>be affected</u> by <u>other factors</u> like stress, disease and malnutrition. <u>Ovulation day may change</u> and hence there is a chance of fertilisation as the fertile period may shift. Sperms and egg can survive in the body for a few days. (any two of the above)	[1] [1] [1]	
	(d)	Sexual intercourse with an infected person OR sharing of sharp needles or blades with infected person Abstinence/ wear condom/ stick to one sex partner/ do not share needles	[1] [1]	
11	(a)	Volume of liquid = $(12.4 \text{ cm})(0.25 \text{ cm}^2) = 3.1 \text{ cm}^3$ mass (in g) = density (in g/cm^3) x volume (in cm^3) = $0.80 \text{ g/cm}^3 \times 3.1 \text{ cm}^3$ = 2.5 g (to 2 s.f)	[1] [1] [1]	
	(b)	Weight = mg = $0.0025 \text{ kg} \times 10 \text{ N/kg}$ = 0.025 N	[1] [1]	Allow ecf from (a)
	(c)	Pressure = weight of liquid / base area = $0.025 \text{ N} / 0.25 \text{ cm}^2$ = 0.10 N/cm^2	[1] [1]	Allow ecf from (b)
	(di)	Radiation	[1]	
	(dii)	Conduction	[1]	
	(e)	Black painted copper	[1]	