

Visit

FREETESTPAPER.com

for more papers



Website: [freetestpaper.com](http://www.freetestpaper.com)



[Facebook.com/freetestpaper](https://www.facebook.com/freetestpaper)



[Twitter.com/freetestpaper](https://www.twitter.com/freetestpaper)

Class	Register Number	Name
-------	-----------------	------



BARTLEY SECONDARY SCHOOL

MID-YEAR EXAMINATION

LOWER SECONDARY SCIENCE

Sec 2 Express

22 May 2019

2 hours

Candidates answer on the Question Paper.
Additional Materials: Multiple Choice Answer sheet

READ THESE INSTRUCTIONS FIRST

Write your class, register number and name on all the work you hand in.
Write in dark blue or black pen.
You may use an HB pencil for any diagrams or graphs.
Do not use staples, paper clips, glue or correction fluid.

Section A

There are **twenty** questions in this section. Answer **all** questions. For each question there are four possible answers, **A, B, C** and **D**.
Choose the **one** you consider correct and record your choice in soft pencil on the separate Multiple Choice Answer Sheet.

Section B and Section C

Answer **all** the questions in the spaces provided.
The number of marks is given in brackets [] at the end of each question or part question.
A copy of the Periodic Table is printed on page 24.

At the end of the examination, submit this question paper and the Multiple Choice Answer Sheet separately

For Examiner's Use	
Section A	
Section B	
Section C	
Total	

This document consists of **24** printed pages.

Section A (20 marks)Answer **all** questions.

For each question, there are four possible answers **A**, **B**, **C** and **D**. Choose the **one** you consider correct and record your choice in soft pencil on the Multiple Choice Answer Sheet.

- 1 What are the changes to the energy of particles and attraction force between particles when a liquid is cooled to become a solid?

	energy of particles	attraction force between particles
A	decreases	decreases
B	decreases	increases
C	increases	decreases
D	increases	increases

- 2 The diagram shows changes in states of matter.

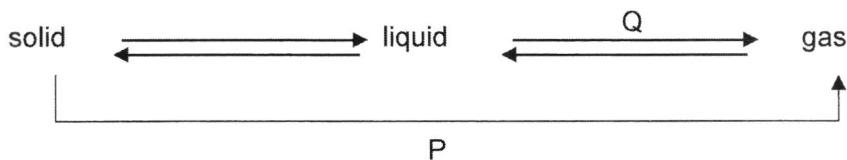

What are the processes represented by P and Q?

	P	Q
A	boiling	condensation
B	condensation	sublimation
C	sublimation	melting
D	sublimation	evaporation

- 3 Which statements describe matter correctly?

- I All the particles of matter are in constant motion.
- II Forces of attraction hold all the particles in solid matter together.
- III Matter is made up of small discrete particles.
- IV The particles in all matter are the same.

- | | | | |
|----------|--------------------|----------|------------------|
| A | I and II only | B | I and III only |
| C | I, II and III only | D | all of the above |

- 4 The particles in a substance are arranged in an orderly manner at 20 °C while they are far apart at 90 °C.

Which statement is a correct conclusion?

- A The substance melts above 90 °C.
 B The substance is a solid at 50 °C.
 C The particles of the substance are closely packed at 10 °C.
 D The particles of the substance have strong attractive forces between them at 100 °C.
- 5 Which diagram shown below represents molecules of a diatomic element?

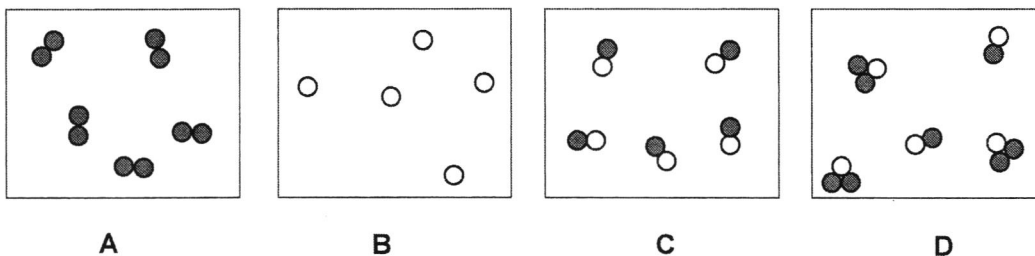

- 6 The atoms of element X have proton number of 16.

Which statement about element X is **incorrect**?

- A It can be found in Group VI of the Periodic Table.
 B It can be found in Period 3 of the Periodic Table
 C It forms an ion with a charge of -2.
 D It has 6 protons in the outer shell of an atom.
- 7 The diagrams below show the electronic structures of four elements.

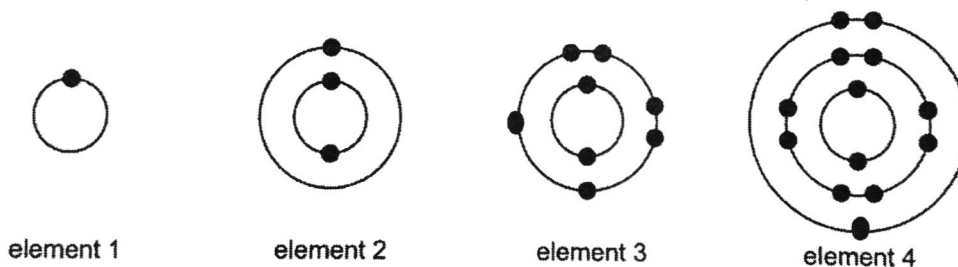

Which elements are metals?

- A 1 and 2 only B 1 and 3 only
 C 1, 2 and 4 only D 2 and 4 only

- 8 How many elements and atoms are there in a unit of magnesium phosphate, $\text{Mg}_3(\text{PO}_4)_2$?

	number of elements	number of atoms
A	3	12
B	3	13
C	4	14
D	4	13

- 9 The table shows the electronic structures of four elements.

Which element is a noble gas?

element	number of electrons	
	first shell	second shell
A	1	0
B	2	0
C	2	2
D	2	6

- 10 Which word equation represents a combustion reaction?

- A copper carbonate \rightarrow copper oxide + carbon dioxide
 B iron + sulfur \rightarrow iron sulfide
 C magnesium + oxygen \rightarrow magnesium oxide
 D sodium + water \rightarrow sodium hydroxide + hydrogen

- 11 Which statement does **not** describe dilute sodium hydroxide correctly?

- A Bubbles are observed when a beaker of dilute nitric acid is added into it.
 B It always turns red litmus paper blue.
 C It is a corrosive liquid and is able to conduct electricity.
 D It is one of the important raw materials to make soaps and detergents.

12 Which statement about physical changes is **not** correct?

- A A physical change can be reversed easily.
- B Dissolving alcohol in water is an example of a physical change.
- C Heat is always given out to the surroundings.
- D No new substance is formed.

13 The diagram shows how a beam of parallel rays bounces off a table top.

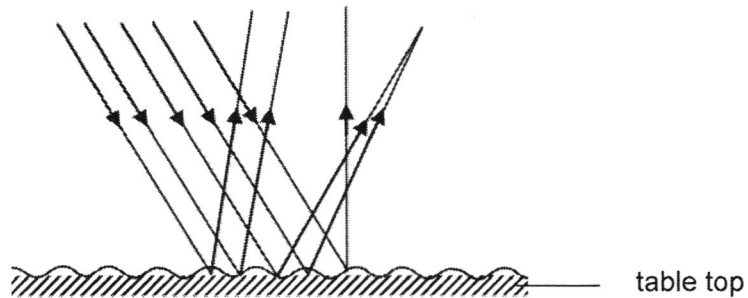

Which statement about the reflection is correct?

- A All the angles of incidence are equal.
- B All the angles of reflection are equal.
- C For each ray, the angle of incidence is equal to the angle of reflection.
- D This is an example of regular reflection.

14 A ray of light is shone vertically at a plane mirror tilted at an angle of 30° to the bench.

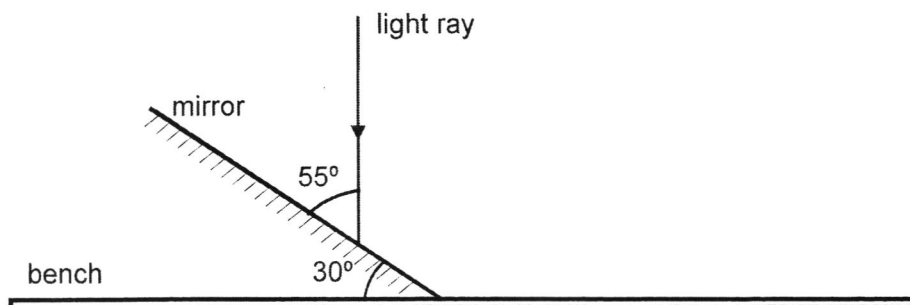

What is the angle of reflection?

- | | | | |
|---|------------|---|------------|
| A | 25° | B | 35° |
| C | 55° | D | 60° |

- 15 David dropped a coin into the pond. While searching for it in the pond, he positioned himself at different locations, X and Y, as shown in the diagram.

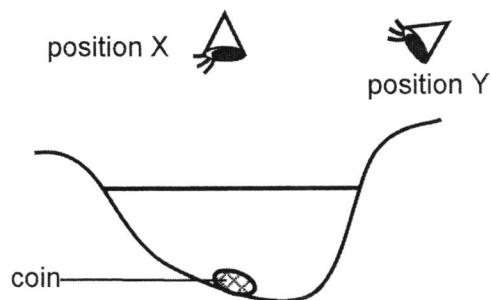

What is true about the position of the image when viewed from positions X and Y?

	from position X	from position Y
A	appears nearer to surface	appears nearer to surface
B	appears nearer to surface	remains at the same position
C	remains at the same position	appears nearer to surface
D	remains at the same position	remains at the same position

- 16 A concave mirror is used in the car headlight.

What is the most important reason why the mirror must be concave?

- A** The image is magnified.
- B** The image is virtual.
- C** The light can be reflected off as convergent beam of light.
- D** The light can be reflected off as parallel beam of light.
- 17 What is the approximate range of audible frequencies for a healthy person?
- A** 2 Hz to 2 kHz
- B** 2 Hz to 20 000 Hz
- C** 20 Hz to 20 kHz
- D** 20 kHz to 20 000 kHz

- 18 The diagram shows the internal structures of a human ear.

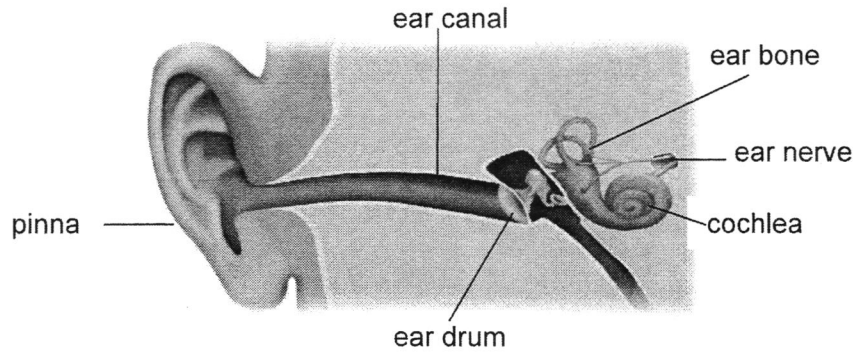

Which function does **not** describe the respective part correctly?

	part	function
A	ear bone	to amplify the vibrations of sound waves
B	ear drum	to receive the vibrations of sound from ear canal
C	cochlea	to send the electrical signal to the brain
D	pinna	to collect sound waves from vibrating sources

- 19 A violin produces a note of frequency 256 Hz.

Which statement about the violin string is correct?

- A It is 256 cm long.
 B It is 256 m long.
 C It produces sound waves travelling at 256 m/s.
 D It vibrates 256 times each second.

- 20 The sound wave from a piano has a higher frequency than that from a drum, but the sound wave from a drum has larger vibrations than that from a piano.

Which instrument produces a higher pitch, and which instrument produces a louder sound?

	higher pitch	louder sound
A	drum	drum
B	drum	piano
C	piano	drum
D	piano	piano

Section B [40 marks]

Answer **all** the questions in the spaces provided.

- B1** A liquid **X**, was allowed to cool in air. The temperature was measured every five minutes. The graph below represents the cooling curve of **X**.

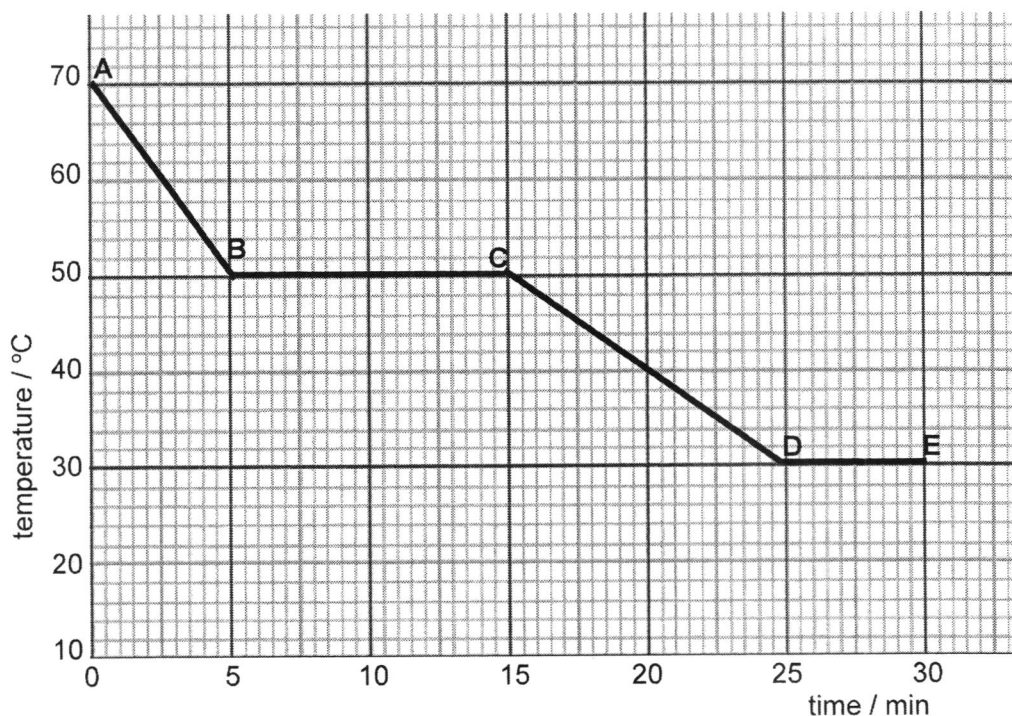

- (a) At which temperature did **X** start to freeze? [1]

- (b) How much time does **X** take to freeze? [1]

- (c) Using the graph above, deduce the room temperature. [1]

- (d) At which section(s) of the graph does **X** exist as solid only. [1]

- (e) **X** has a boiling point of 126 °C.
- (i) Explain, in terms of particle theory, how the movement of particles changes as it is heated from 100 °C to 150 °C?

.....

.....

..... [1]

- (ii) Draw a diagram in the box below to show the arrangement of particles **X** at 120 °C.

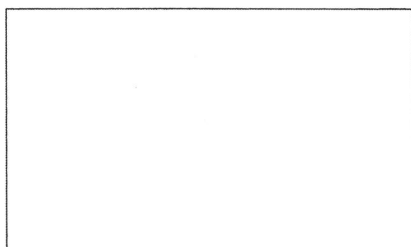

[1]

B2 The symbols of six particles are shown below.

Na⁺ Ca²⁺ O²⁻ Al S²⁻ Ar

- (a) Which particles have more electrons than protons?

[1]

- (b) Which two ions have the same electronic structure?

[1]

- (c) Using 'dot and cross', draw the electronic structure of S²⁻ in the space below.

[1]

- B3** The table below shows the details of eight particles, **Q, R, S, T, U, V, W** and **X**. The letters do not correspond to the symbols of the elements in the Periodic Table.

particles	nucleon number	proton number	total number of electrons
Q	3	2	2
R	10	5	5
S	11	5	5
T	14	7	7
U	20	10	10
V	23	11	11
W	27	13	10
X	35	17	18

From the Table, choose the particle(s) that represent(s)

- (a) atom with a single neutron,

_____ [1]

- (b) atom(s) from Group V of the Periodic Table,

_____ [1]

- (c) atom(s) with an electronic structure of 2, 8,

_____ [1]

- (d) atom(s) that form(s) a salt with chlorine,

_____ [1]

- (e) ion with a single negative charge,

_____ [1]

- (f) isotopes of the same element,

_____ [1]

- (g) unreactive atom(s).

_____ [1]

B4 Some chemical reactions are listed below.

thermal decomposition oxidation electrolysis
 neutralisation combustion

Identify the type of reaction that had taken place for each of the description in the table.

	description	type of chemical reaction taken place
(a)	Some sugar crystals were heated to leave behind carbon as a residue in an evaporating dish. Water vapour was also produced.	
(b)	The energy that is needed for cars to move is provided by the reaction between petrol and air.	
(c)	When electricity is passed into water, two gases, hydrogen and oxygen, can be collected.	
(d)	Iron nails turn rusty easily in the presence of water and oxygen.	

[4]

B5 (a) Several reactions involving hydrochloric acid are shown below.

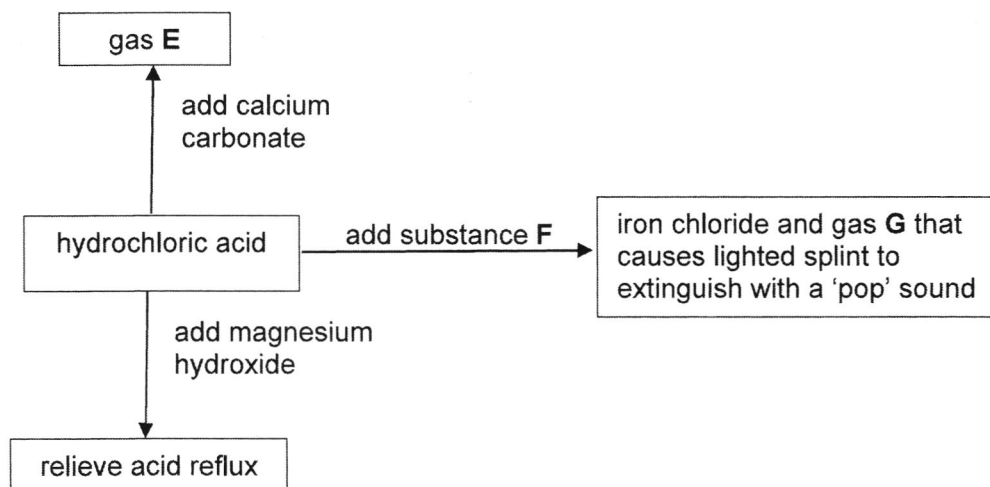

(i) Suggest the identities of E, F and G.

E:

F:

G:

[3]

- (ii) Describe a test to identify gas E.

test:

_____ [1]

observation:

_____ [1]

- (b) Hydrochloric acid is produced in the stomach to aid food digestion. However, when there is too much acid in the stomach, there will be discomfort due to acid reflux.

Doctors will often prescribe antacids to treat such conditions. Antacids neutralise stomach acids and provide you with fast relief from gastritis pain. These antacids commonly contain either calcium carbonate or magnesium hydroxide as shown below.

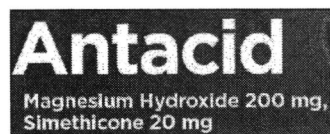
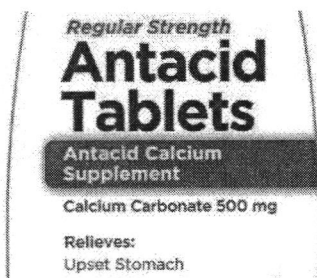

- (i) Write the word equation, to show how magnesium hydroxide in antacid tablets helps to treat acid reflux.

_____ [1]

- (ii) A common side-effect of antacid use is bloating of the stomach, where gas builds up in the stomach and causes discomfort.

Hence, explain if calcium carbonate is better as an antacid compared to magnesium hydroxide.

 _____ [2]

B6 The figure shows the position of a man, flower pot and a stool with respect to a mirror.

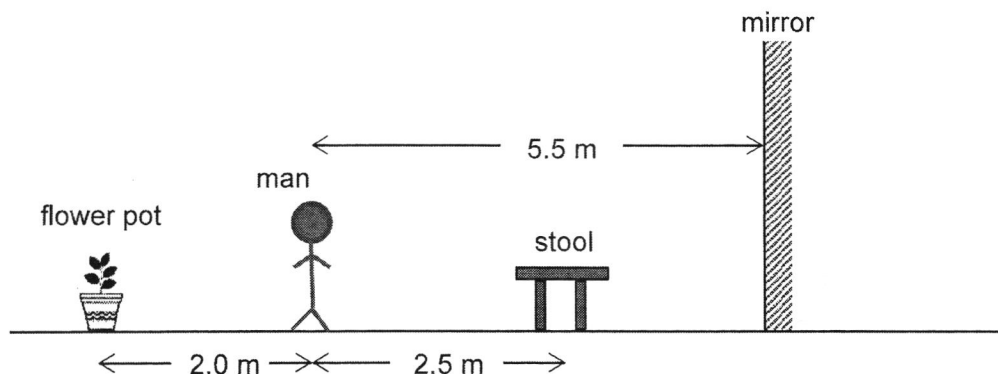

(a) What is the distance from the man to the image of the flower pot. [1]

..... [1]

(b) If the mirror is shifted 1.5 m towards the man, calculate the distance from the stool to the image of the man. [1]

..... [1]

(c) Beside the image distance, state **two** other characteristics of the image of the man formed in the mirror. [2]

..... [2]

(d) The mirror is moved away from the man at a speed of 0.5 m/s.

(i) Is the image of the stool moving towards, stationary or moving away from the man? [1]

..... [1]

(ii) Find the speed at which the image of the stool is moving away from the man.

speed: [1]

B7 (a) The diagrams below represent three sound waves, **P**, **Q** and **R**.

The scales in the three diagrams are the same.

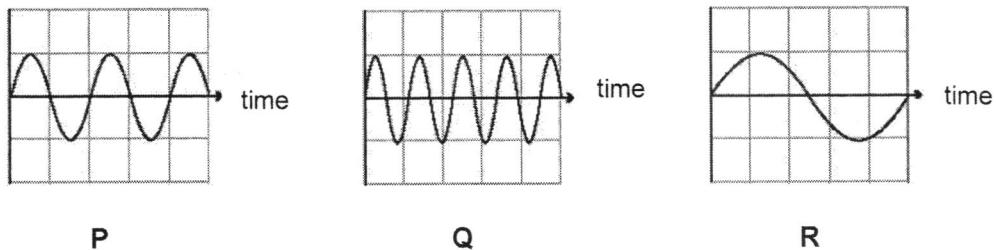

(i) Which sound **P**, **Q**, or **R** has the **lowest** pitch?

_____ [1]

(ii) Explain your answer in (i).

_____ [1]

(iii) State a similarity in the three sound waves shown above.

_____ [1]

(iv) Explain your answer in (iii).

_____ [1]

(b) (i) What is ultrasound?

 _____ [1]

(ii) State one application of ultrasound in the medical field.

 _____ [1]

Section C [40 marks]

Answer **all** the questions in the spaces provided.

- C1 (a)** Titan is the largest moon of Saturn and the second-largest natural satellite in the Solar System. It is the only moon known to have a dense atmosphere.

The surface features are similar to those of Earth, with presence of rivers, lakes, seas and deltas. Its atmosphere has temperature of about $-179\text{ }^{\circ}\text{C}$.

Titan's atmosphere is largely nitrogen, 97%; minor components of methane, ethane, hydrogen, argon, water etc.

The melting point and boiling point of these substances are shown below.

substance	melting point / $^{\circ}\text{C}$	boiling point / $^{\circ}\text{C}$
hydrogen	-259	- 253
nitrogen	-210	-196
ethane	-183	-89
methane	-182	-162
argon	-189	-186
water (trace amount)	0	100

- (i) From the information in the table above, name substance(s) which may be found in the seas of Titan. Explain your answer.

.....

[2]

- (ii) Which of the above substance(s) would exist as

1 a gas, and

.....

[1]

2 a solid in Titan's atmosphere?

.....

[1]

- (iii) Comment on whether Titan is able to support living organisms similar to those found on Earth.

.....

[1]

- (iv) If a sample from Titan's atmosphere was brought to Earth, what changes would occur in the sample?

.....

[2]

- (b) The figure below shows the structure of a carbon isotope.

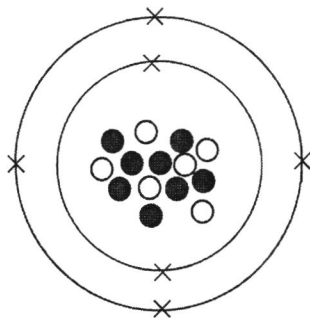

Complete the table below to show the names, relative charges and relative masses of the sub-atomic particles represented by the symbols in the carbon isotope.

symbol	name	relative charge	relative mass
●			
○			
×			

[3]

- C2 (a) The table below shows the pH value of four colourless solution and the colour change when using Universal Indicator on them.

solution	pH	colour with Universal Indicator
P	1	red
Q	4	
R	7	green
S	13	

- (i) State in the table above, the colour of the Universal Indicator in solution **Q** and **S**. [1]
- (ii) Name the type of reaction when solution **Q** reacts with solution **S**. [1]

- (iii) Solution **P** and **S** are of equal concentration.

When equal volumes of solution **P** and solution **S** are mixed with Universal Indicator, a green colour mixture is obtained. Explain your answer.

..... [1]

- (iv) Solution **S** is a metallic hydroxide solution.
The reaction of solution **P** and solution **S** produces sodium nitrate.

Suggest the chemical names of solution **P** and **S**.

solution **P**:

solution **S**: [1]

- (b) An air bag is a type of vehicle safety device and is an occupant restraint system. The chemical responsible for the air bag reaction is sodium nitride which decomposes at 300 °C. A car crash trip sensor that send an electric signal to an ignitor.

The heat generated causes sodium nitride to decompose into sodium metal and nitrogen gas, which inflates the air bag out of the car's steering wheel as shown below.

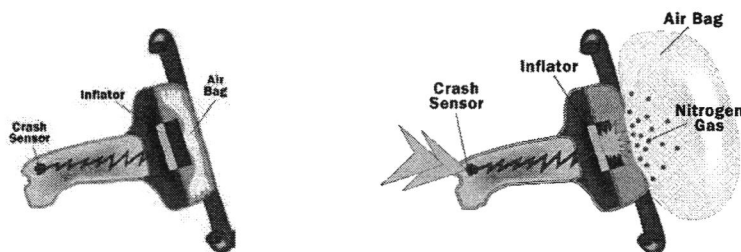

- (i) Using ○ to represent an atom of sodium and ● to represent an atom of nitrogen, draw a model to show how sodium nitride (Na_3N) decomposes into sodium metal (Na) and nitrogen gas (N_2).

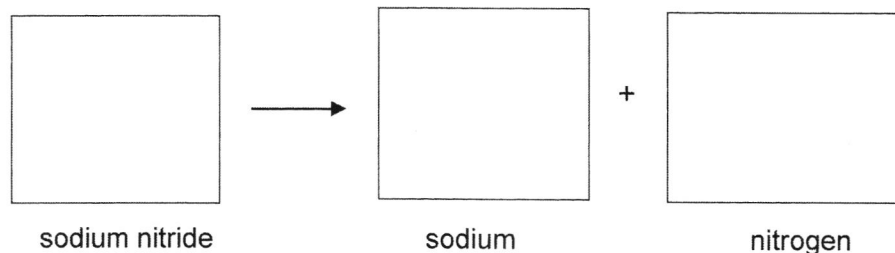

[2]

- (ii) Write a balanced chemical equation to represent the reaction above.

..... [1]

- (iii) Explain, in terms of particle theory, why the air bag can be stored within the limited space in the car's steering wheel.

_____ [1]

- (iv) Draw in the space below the electronic structure of a sodium atom.

[1]

- (v) The sodium that is produced during the reaction is a very reactive metal. Using the electronic structure of sodium in (iv), explain why sodium is a reactive metal.

_____ [1]

- C3** (a) A molecule of a substance is made up of an unknown element Y, hydrogen and carbon. Its chemical formula is shown below.



One molecule of this substance has a total number of 50 protons.

- (i) Using the Periodic Table, state the number of protons found in one hydrogen atom and one carbon atom.

hydrogen:

carbon:

[1]

- (ii) Hence, calculate the number of protons found in one atom of element Y.

- (iii) Name element Y.

[1]

_____ [1]

- (iv) Is the substance above classified as a molecule of a compound or a molecule of an element? Explain your answer.

[2]

- (b) The diagram below shows a fishing boat which is fitted with a device at the bottom to transmit sonar waves to locate fishes.

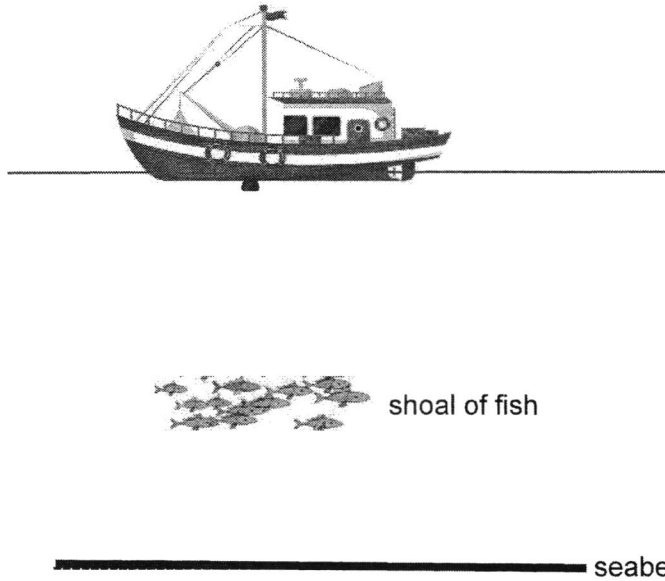

Two signals captured by the receiver of the sonar waves as shown below are the echo reflected off from the sea under the fishing boat.

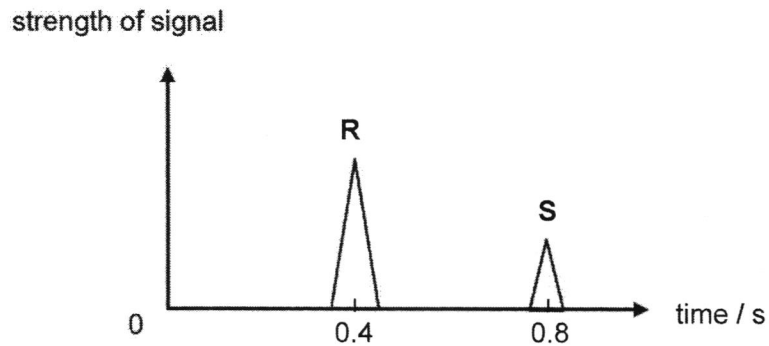

- (i) Identify the objects that the sonar waves bounce off which resulted in the two signals, **R** and **S**.

signal **R**:

signal **S**:

[1]

- (ii) Explain why signal **S** is of lesser strength.

.....
..... [1]

- (iii) Using information from the graph shown on page 19, calculate the depth of the shoal of fish below the boat.
The speed of sound in water is approximately 1500 m/s.

depth = m [2]

- (c) An explosion happened in the sea underwater. The people in a submarine underwater heard the explosion before the people on a ship above water.

Assuming that the distance between the explosion and both groups of people is the same.

Suggest a possible explanation for the situation.

.....
..... [1]

- C4 (a) John is standing at position 1 in a room, He saw the image of an object, \triangle , behind a partition of the room through a plane wall mirror as shown below.

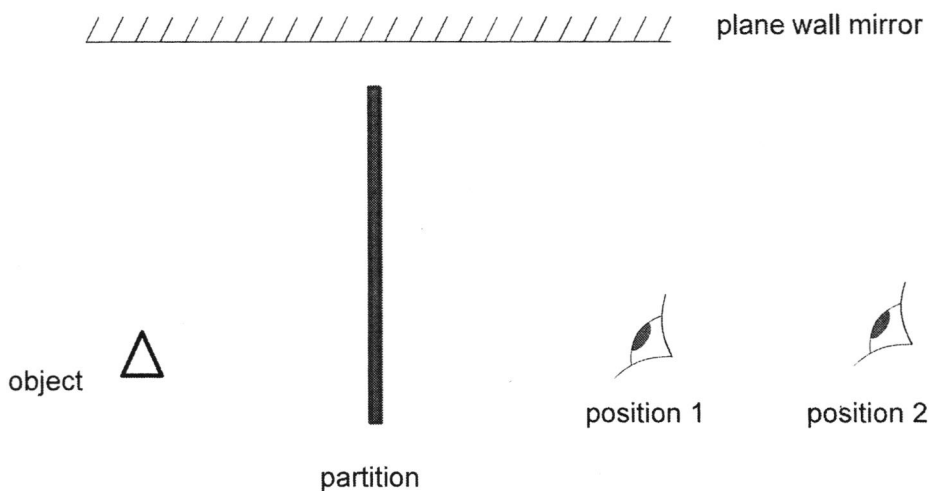

- (i) On the figure above, draw the image of the object formed by the plane wall mirror and label it as 'I'. [1]
- (ii) Draw **two** light rays on the figure above to show how the image of the object can be seen by John in position 1. [2]
- (iii) John moves further away from the partition to stand at position 2. Using a ray diagram, determine whether he is able to see the image of the object behind the partition. Explain your answer with the aid of a single light ray drawn in the figure above.

[2]

- (b) Read the article below and answer the following questions.

Refraction is the bending of the path of light as it passes from one medium into another medium. The refraction occurs at the boundary of a material and is caused by a change in the speed of the light ray upon crossing the boundary.

The tendency of a ray of light to bend one direction or another is dependent upon whether the light wave speeds up or slows down upon crossing the boundary. The speed of light ray is dependent upon the optical density of the medium through which it moves. As the optical density increases, the speed of light in that material decreases.

If a ray of light passes across the boundary from a optically less dense medium to a denser medium, then the light ray bend towards the normal line. If a ray of light passes across the boundary from a optically denser medium to a less dense medium, the light ray bends away from the normal line.

A list of optical densities of various media is shown in the table below.

medium	optical density
vacuum	1.0000
air	1.0003
glass	1.51
water	1.333

- (i) Using the information from the article, arrange the speed of light in air, glass and water in ascending order.

..... [1]

- (ii) A student shines a light ray at the base of the glass tank, as shown in the diagram below.

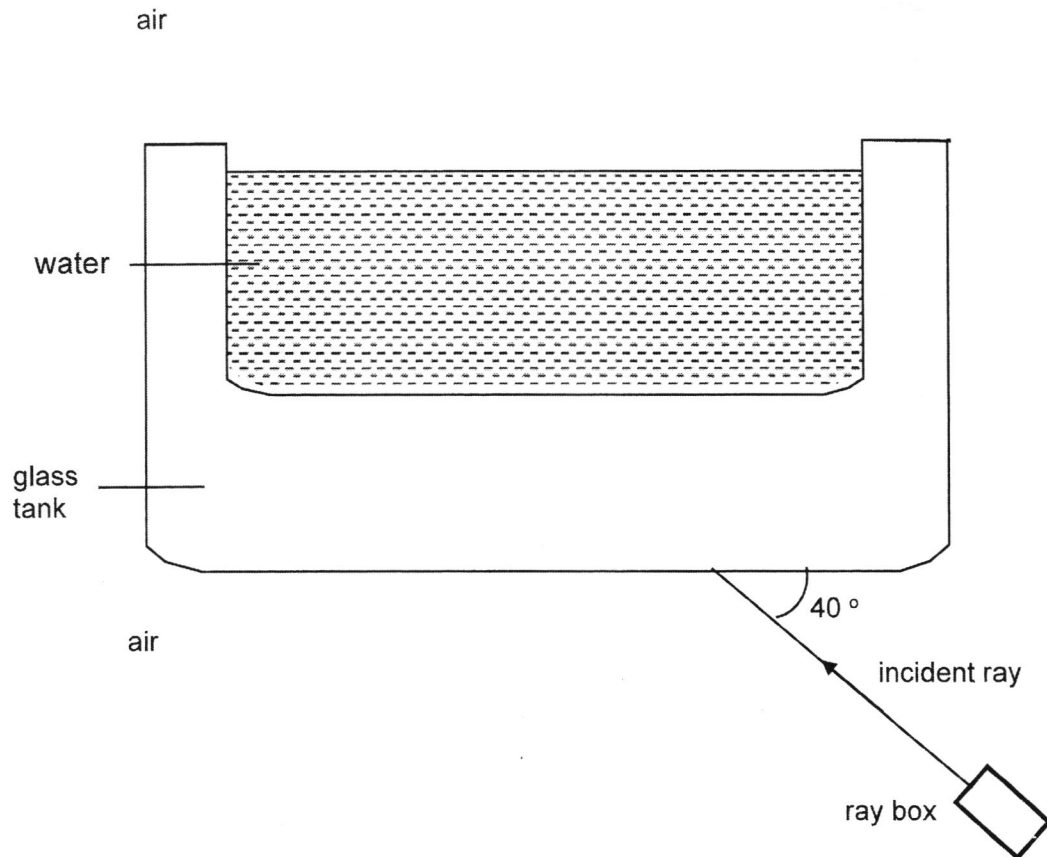

- 1 What is angle of incidence when the light ray strikes the base of the glass tank? [1]
.....
- 2 Draw in the diagram, the reflected ray when the incident ray strikes the base of the glass tank and label it as(2). [1]
- 3 Complete the diagram to show the path of light as it travels through the base of glass tank, water and air. [2]

End of Paper

The Periodic Table of Elements

		Group																
I	II	III	IV	V	VI	VII						0						
3 Li lithium 7	4 Be beryllium 9	<div style="border: 1px solid black; padding: 5px; display: inline-block;"> Key proton (atomic) number atomic symbol name relative atomic mass </div>										2 He helium 4						
11 Na sodium 23	12 Mg magnesium 24											5 B boron 11	6 C carbon 12	7 N nitrogen 14	8 O oxygen 16	9 F fluorine 19	10 Ne neon 20	
19 K potassium 39	20 Ca calcium 40	21 Sc scandium 45	22 Ti titanium 48	23 V vanadium 51	24 Cr chromium 52	25 Mn manganese 55	26 Fe iron 56	27 Co cobalt 59	28 Ni nickel 59	29 Cu copper 64	30 Zn zinc 65	31 Al aluminium 27	32 Si silicon 28	33 P phosphorus 31	34 S sulfur 32	35 Cl chlorine 35.5	36 Ar argon 40	
37 Rb rubidium 85	38 Sr strontium 88	39 Y yttrium 89	40 Zr zirconium 91	41 Nb niobium 93	42 Mo molybdenum 96	43 Tc technetium -	44 Ru ruthenium 101	45 Rh rhodium 103	46 Pd palladium 106	47 Ag silver 108	48 Cd cadmium 112	49 In indium 115	50 Sn tin 119	51 Sb antimony 122	52 Te tellurium 128	53 I iodine 127	54 Xe xenon 131	
55 Cs caesium 133	56 Ba barium 137	57-71 lanthanoids Ba 137	72 Hf hafnium 178	73 Ta tantalum 181	74 W tungsten 184	75 Re rhenium 186	76 Os osmium 190	77 Ir iridium 192	78 Pt platinum 195	79 Au gold 197	80 Hg mercury 201	81 Tl thallium 204	82 Pb lead 207	83 Bi bismuth 209	84 Po polonium -	85 At astatine -	86 Rn radon -	
87 Fr francium -	88 Ra radium -	89-103 actinoids Ba 137	104 Rf Rutherfordium -	105 Db dubnium -	106 Sg seaborgium -	107 Bh bohrium -	108 Hs hassium -	109 Mt meitnerium -	110 Ds darmstadtium -	111 Rg roentgenium -	112 Cn copernicium -	114 Fl flerovium -	116 Lv livermorium -	118 Og oganeson -	119 Uue unbinilium -	120 Uuo unbinilium -	121 Uuh ununilium -	122 Uuq ununilium -

lanthanoids

57 La lanthanum 139	58 Ce cerium 140	59 Pr praseodymium 141	60 Nd neodymium 144	61 Pm promethium -	62 Sm samarium 150	63 Eu europium 152	64 Gd gadolinium 157	65 Tb terbium 159	66 Dy dysprosium 163	67 Ho holmium 165	68 Er erbium 167	69 Tm thulium 169	70 Yb ytterbium 173	71 Lu lutetium 175
89 Ac actinium -	90 Th thorium 232	91 Pa protactinium 231	92 U uranium 238	93 Np neptunium -	94 Pu plutonium -	95 Am americium -	96 Cm curium -	97 Bk berkelium -	98 Cf californium -	99 Es einsteinium -	100 Fm fermium -	101 Md mendelevium -	102 No nobelium -	103 Lr lawrencium -

actinoids

The volume of one mole of any gas is 24 dm³ at room temperature and pressure (r.t.p.).

Bartley Secondary School
Sec 2E Mid-Year Exam (2019)
Marking scheme

Section A: (20 marks)

1	B	6	D	11	A	16	D
2	D	7	D	12	C	17	C
3	C	8	B	13	C	18	C
4	C	9	B	14	B	19	D
5	A	10	C	15	A	20	C

Section B: (40 marks)

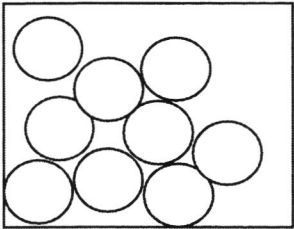
B1	(a)	50 °C	1
	(b)	10 min	1
	(c)	30 °C	1
	(d)	CD & DE	1
	(e) (i)	From 100 °C to 126 °C, the particles liquid <u>slide over one another</u> and when it is heated to 126 °C and above, the particle are able to move <u>freely at high speed</u> .	1
	(ii)	liquid state 	1
B2	(a)	O ²⁻ and S ²⁻	
	(b)	Na ⁺ and O ²⁻	

			1
--	--	--	---

B3	(a)	Q	1
	(b)	T	1
	(c)	U	1
	(d)	V	1
	(e)	X	1
	(f)	R and S	1
	(g)	Q and U	1

B4	(a)	thermal decomposition	1	
	(b)	combustion	1	
	(c)	electrolysis	1	
	(d)	oxidation	1	
B5	(a)	(i)	E – carbon dioxide F – iron G - hydrogen	1 1 1
		(ii)	pass the gas through the clear limewater	1
		(iii)	white precipitate is formed	1
	(b)	(i)	magnesium + hydrochloric acid \longrightarrow magnesium chloride + water hydroxide or magnesium + acid \longrightarrow salt + water hydroxide	1
		(ii)	No, Magnesium hydroxide is better.	1

			As taking calcium carbonate, <u>carbon dioxide gas</u> is produced after reacting with hydrochloric acid. This resulting in bloating of the stomach. or As taking magnesium hydroxide, forming salt and water but <u>no gas</u> , so that to prevent stomach bloating.	1
B6	(a)		13.0 m	1
	(b)		5.5 m	1
	(c)		virtual upright laterally inverted same size as an object (any 2)	2
	(d)	(i)	away	1
	(d)	(ii)	1.0 m/s	1
B7	(a)	(i)	R	1
			It's frequency is the lowest.	1
		(ii)	They have same loudness. / They have same amplitudes.	1
			The amplitudes are the same. / The height of the sound waves are the same	1
	(b)	(a)	Ultrasound is sound with frequencies above 20,000 Hz (20 kHz), which cannot be heard by the human ear.	1
		(b)	to observe foetuses in pregnant mothers / detect cancers / observe tumours within the body / break up kidney stones (any 1)	1

Section C (40 Marks)

C1	(a)	(i)	ethane and methane	1
			They exist as liquid state in Titan atmosphere (- 179 °C).	1
		(ii)	gas -- hydrogen, nitrogen and argon	1
			solid -- water	1
		(iii)	Oxygen is absent in Titan atmosphere. no liquid water is present. (Accept)	1
		(iv)	Water will be present as liquid state	1
			Ethane & methane will be present as gaseous state.	1

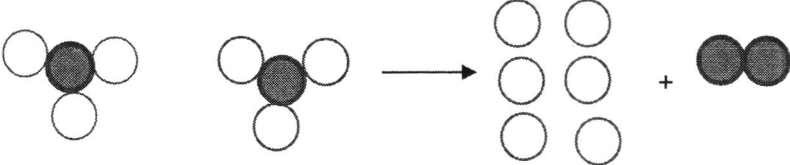
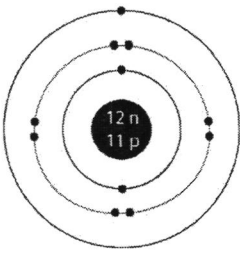
	(b)		<table border="1"> <thead> <tr> <th>symbol</th> <th>name</th> <th>relative charge</th> <th>relative mass</th> </tr> </thead> <tbody> <tr> <td>●</td> <td>neutron</td> <td>0</td> <td>1</td> </tr> <tr> <td>○</td> <td>proton</td> <td>+ 1</td> <td>1</td> </tr> <tr> <td>×</td> <td>electron</td> <td>- 1</td> <td>1/1840</td> </tr> </tbody> </table>	symbol	name	relative charge	relative mass	●	neutron	0	1	○	proton	+ 1	1	×	electron	- 1	1/1840	3
symbol	name	relative charge	relative mass																	
●	neutron	0	1																	
○	proton	+ 1	1																	
×	electron	- 1	1/1840																	
C2	(a)	(i)	Q -- orange S -- violet	1																
		(ii)	neutralisation	1																
		(iii)	The products, salt and water formed are neutral solutions	1																
		(v)	solution P – nitric acid solution S --- sodium hydroxide	1																
	(b)	(i)	 <p>correct substance – 1 m balance – 1 m</p>	2																
		(ii)	$2\text{Na}_3\text{N} \longrightarrow 6\text{Na} + \text{N}_2$	1																
		(iii)	sodium nitride is a solid, the particles are closely packed.	1																
		(iv)		1																
		(v)	It has only one valence electron which is easily lost.	1																
C3	(a)	(i)	hydrogen – 1 carbon – 6	1																
		(ii)	$(50 - 12 - 4) / 2$ $= 17$	1																
		(iii)	chlorine (accept ecf)	1																
		(iv)	Molecule of compound. It is made up of 3 different types of elements (atoms).	1 1																

	(b)	(i)	R – shoal of fish S – seabed	1
		(ii)	The seabed is further away from the ship. Sound lose energy when the distance increases.	1
		(iii)	Depth = (speed x time) / 2 = 1500 x 0.4/2 = 300 m	1 1
	(c)		Sound travel faster in the water than in air.	1

C4

(a)

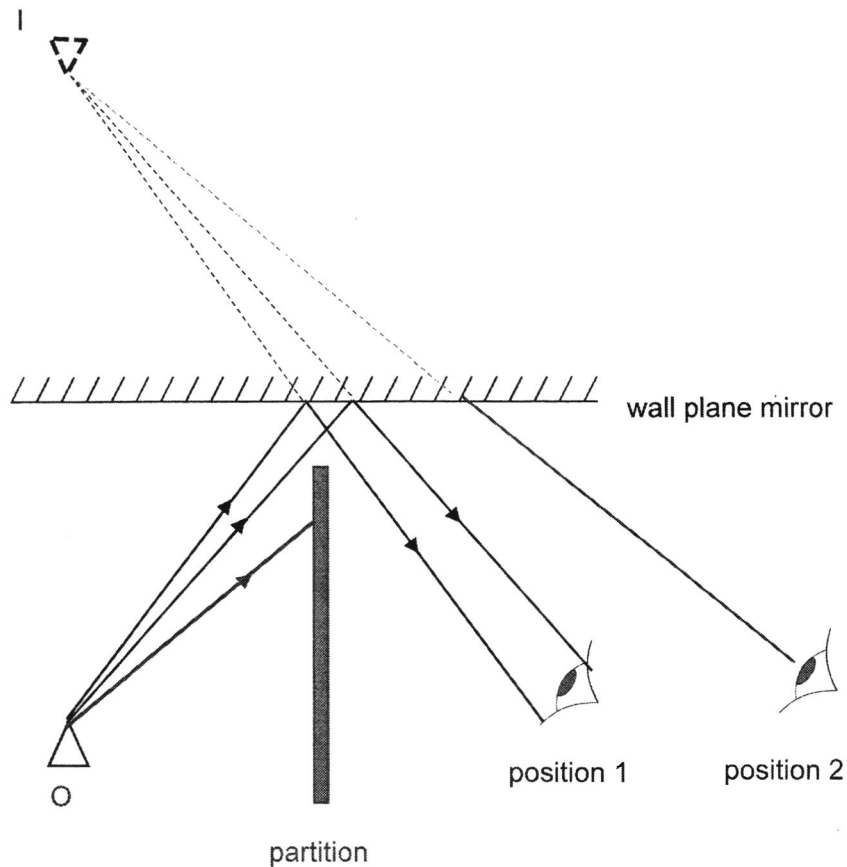

- (i) correct location of image 1
- (ii) draw incident rays with arrow correctly 1
draw reflected rays and dotted line to image 1
- (iii) Show incident ray is blocked by partition and with explanation 1
- Show in the diagram the line from eye to image. Dotted line behind the mirror and solid line in front of the mirror. 1
(no arrow(s) minus 1 m)

C5

(b)

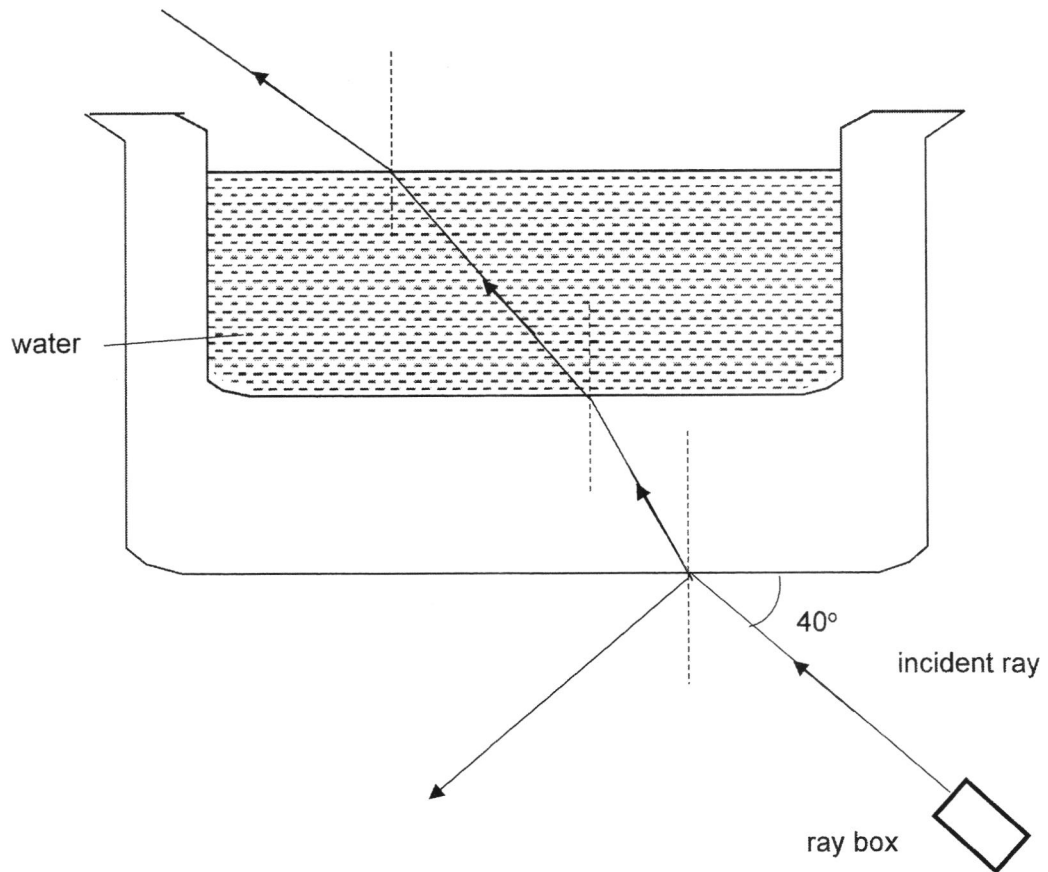

(i)	glass , water, air (correct order)	1
(ii)	(1) 50°	1
	(2) Draw and label reflected ray correctly.	1
	(3) bend toward normal at the base of tank bend away from glass to water	1
	bend away from water to air and parallel to incident ray	1

End of Paper