

Visit

FREETESTPAPER.com

for more papers



Website: [freetestpaper.com](http://www.freetestpaper.com)



[Facebook.com/freetestpaper](https://www.facebook.com/freetestpaper)



[Twitter.com/freetestpaper](https://www.twitter.com/freetestpaper)



SPRINGFIELD SECONDARY SCHOOL
End-Of-Year Examination 2021

STUDENT
NAME

CLASS

S		-	
---	--	---	--

INDEX
NUMBER

--	--

SCIENCE
SECONDARY 2 EXPRESS
 Paper 1 Multiple Choice

5 October 2021
Papers 1 and 2: 1 hour 30 minutes

Additional Materials: Multiple Choice Answer Sheet

READ THESE INSTRUCTIONS FIRST

Write in soft pencil.

Do not use staples, paper clips, glue or correction fluid.

Write your name, class and index number on the Answer Sheet in the spaces provided.

There are **twenty-five** questions on this paper. Answer **all** questions. For each question, there are four possible answers **A, B, C** and **D**.

Choose the **one** you consider correct and record your choice in **soft pencil** on the separate Answer Sheet.

Read the instructions on the Answer Sheet very carefully.

Each correct answer will score one mark. A mark will not be deducted for a wrong answer.

Any rough working should be done in this booklet.

A copy of the Periodic Table is printed on page 12.

The use of an approved calculator is expected where appropriate.

Do not turn over this question paper until you are told to do so.

This question paper consists of 12 printed pages.

[Turn Over

2

- 1 An astronaut in his spacesuit has a mass of 75 kg on Earth. He can jump 15 cm off the surface of the Earth. When he is on the Moon, he can jump higher than 15 cm.

Which of the following descriptions is correct?

- A His mass is the same on the Moon as on Earth.
- B His mass is smaller on the Moon than on Earth.
- C His weight is the same on the Moon as on Earth.
- D His weight is greater on the Moon than on Earth.

- 2 The figure shows forces acting on a body.



What is the resultant force acting on the body?

- A 1 N to the left
 - B 2 N to the right
 - C 4 N to the left
 - D 24 N to the right
- 3 In which of the following positions will a person exert the greatest pressure on the ground?
- A The person does a handstand on one of his hands.
 - B The person lies flat on his back.
 - C The person sits cross-legged on the floor.
 - D The person stands on both legs.

3

- 4 Two different blocks of metal, **X** and **Y**, hang from spring balances as shown below.

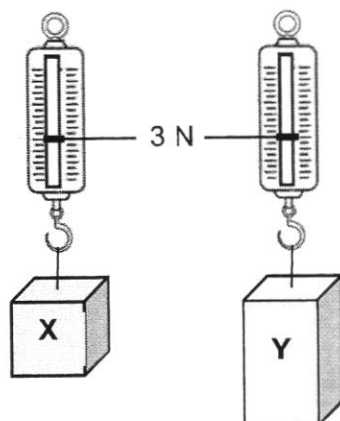

Which of the following statements about metals **X** and **Y** is correct?

- A** They have different volume and different weight.
- B** They have different density and different mass.
- C** They have the same mass but different weight.
- D** They have the same weight but different density.
- 5 A man lifts 20 bricks, each weighing 6N.
- What other piece of information is needed to calculate the work done in lifting the bricks?
- A** the height he lifts the bricks
- B** the mass of the bricks
- C** the time taken to lift the bricks
- D** the volume of the bricks
- 6 Louis lifts some boxes of identical weight from the ground onto a lorry. In the morning, it takes him 3 s to lift each box. Later in the day, it takes him 2 s.
- Which statement is correct?
- A** Later in the day, less work is done in lifting each box.
- B** Later in the day, more work is done in lifting each box.
- C** Later in the day, less power is developed in lifting each box.
- D** Later in the day, more power is developed in lifting each box.

[Turn Over

- 7 The sum of the gravitational potential energy and kinetic energy of an object falling freely under gravity is called its mechanical energy.

Assuming that air resistance is negligible, which of the following best represents the changes in the different energies when the object is falling freely under gravity?

	gravitational potential energy	kinetic energy	mechanical energy
A	decreases	increases	increases
B	decreases	increases	remains constant
C	increases	decreases	decreases
D	increases	decreases	remains constant

- 8 Equal volumes of alcohol and water are added into a beaker.

Which statement explains why the total volume of the mixture is less than the sum of the two volumes added up?

- A** The particles are always in constant and random motion.
- B** The particles are arranged in an orderly manner.
- C** The particles can be compressed because they are far apart.
- D** The particles fill up the spaces between each other.
- 9 Which of the following processes involves the weakening of forces of attraction between the particles?
- A** copper(II) sulfate solution crystallises into copper(II) sulfate crystals
- B** morning dew droplets forming on grass
- C** rock sugar melts in a cup
- D** water freezes to ice

- 10** A substance can exist in three different states: solid, liquid or gas.
Each statement below describes a process which involves a change of state.

process **X**: Molecules start to move further away from each other at high speeds in random directions.

process **Y**: Molecules stop moving throughout the substance and just vibrate about fixed positions.

Which process do these statements describe?

	process X	process Y
A	boiling	freezing
B	condensation	boiling
C	freezing	boiling
D	melting	condensation

- 11** An element, **X**, has p protons and n neutrons.

Which row gives the possible number of subatomic particles in a positive ion of **X**?

	number of protons	number of neutrons	number of electrons
A	p	$n + 1$	$p - 1$
B	p	n	$p - 1$
C	$p + 1$	$n + 1$	p
D	$p - 1$	$n - 1$	$p + 1$

[Turn Over

- 12 The table shows information about particles X and Y.

particle	number of protons	number of neutrons	electronic structure
X	12	12	2,8
Y	20	20	2,8,8

Which statement is correct for both X and Y?

- A They are atoms of metals.
 B They are atoms of noble gases.
 C They are isotopes of the same element.
 D They are positive ions.
- 13 The diagram shows the arrangement of electrons in an ion of an element with a charge of -1 .

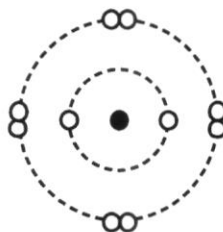

Which group and period does the atom of this element belong to in the Periodic Table?

	group	period
A	I	2
B	I	3
C	VII	2
D	VII	3

- 14 The graph shows how the pH changes in a reaction between an acid and an alkali.

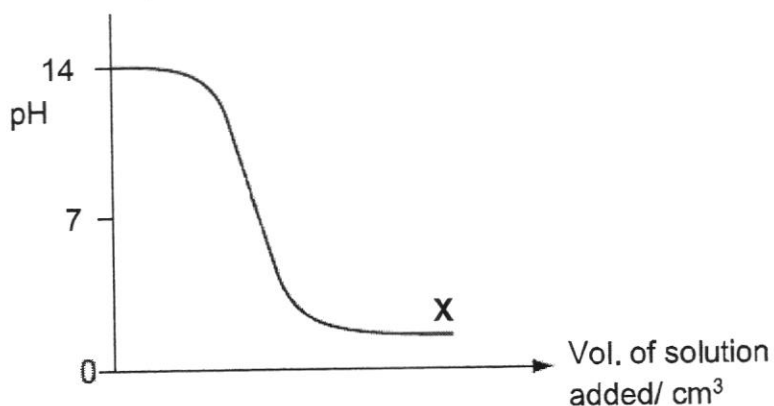

Which of the following statement(s) could be deduced from the graph?

- 1 A gas is produced at part **X** of the graph.
- 2 An acid is added to a fixed volume of an alkali.
- 3 Salt and water are produced at part **X** of the graph.

A 1 and 3 only

B 1 and 2 only

C 2 and 3 only

D 1, 2 and 3

- 15 A student would like to coat a spoon with a layer of copper metal.

Which of the following is the correct set-up for this electroplating process?

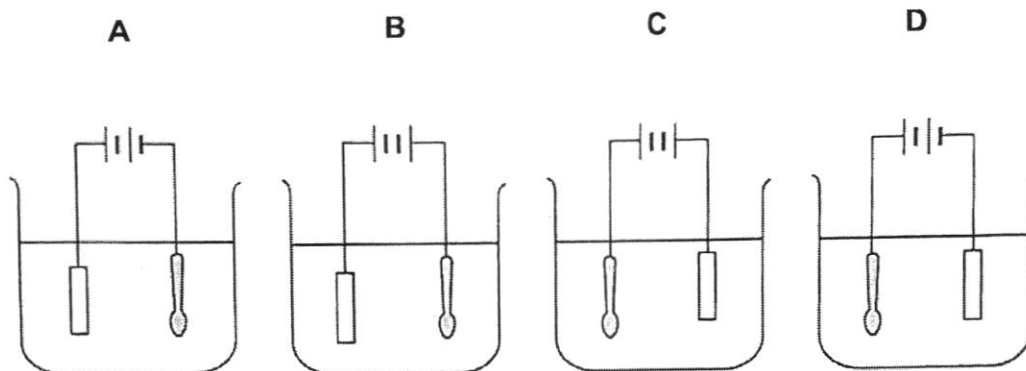

- 16 Which statement describes an alkali correctly?

- A** A strong alkali has a low pH.
- B** A weak alkali has sour taste.
- C** Alkali is a base that is soluble in water.
- D** Alkali is not corrosive.

[Turn Over

- 17 The diagram below shows the colour range of three pH indicators, methyl orange, bromothymol blue and phenolphthalein.

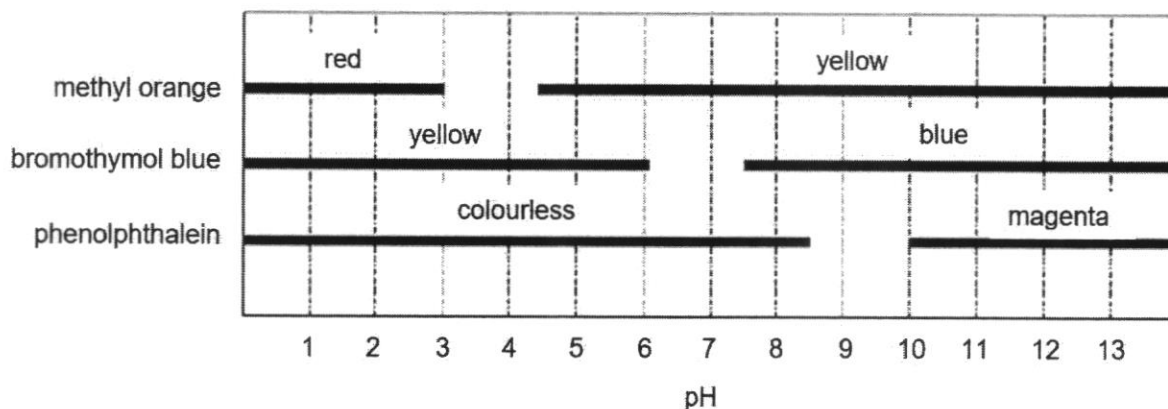

When added separately to solution **X**, methyl orange is yellow, bromothymol blue is blue and phenolphthalein is colourless.

What is the pH range of solution **X**?

- A 4.5 to 6.0 B 6.0 to 7.5
 C 7.5 to 8.5 D 8.5 to 10.0
- 18 A card with the word 'PENCIL' is placed perpendicular to the plane mirror as shown in the diagram.

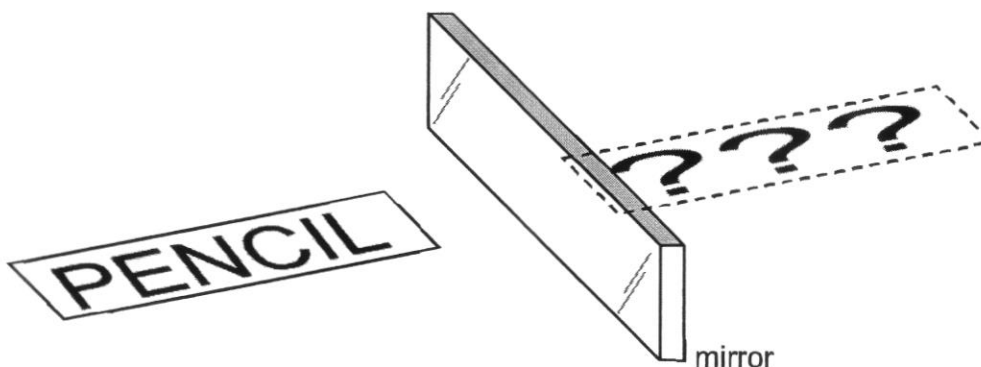

How would the image in the mirror appear?

- A JICNEP
 B PENCIL
 C PEJICN
 D JICNEP

19 A person stands at point X as shown in the diagram below.

Which of the pins (1, 2, 3, 4 and 5) can the person see in the mirror?

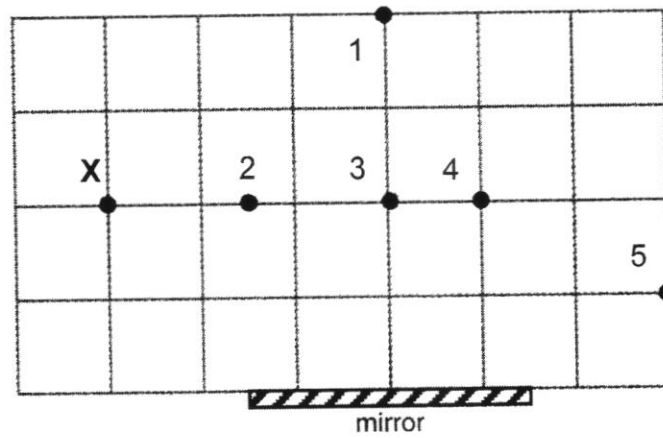

- A 1 and 3 only
- B 3 and 4 only
- C 2, 3 and 5 only
- D 3, 4 and 5 only
- 20 Which of the following are the characteristics of an image formed by a plane mirror and a convex mirror?

	image formed by plane mirror	image formed by convex mirror
A	same size	diminished
B	same size	inverted
C	upright	enlarged
D	virtual	real

[Turn Over

- 23** A metal box has four different surfaces: dull black, shiny black, dull silver and shiny silver. The box is filled with boiling water so that each surface is at the same temperature. A sensor measures the amount of radiation from each surface. The box is rotated such that the sensor will be facing the surface when a measurement is taken.

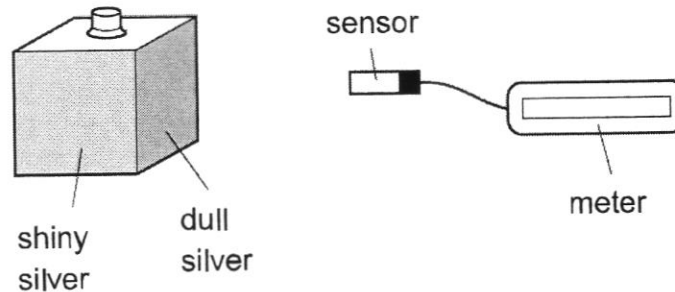

Which surface emits the least radiation and which surface emits the most radiation?

	least	most
A	dull black	shiny silver
B	dull silver	shiny black
C	shiny black	dull silver
D	shiny silver	dull black

- 24** A wire has a current of 800 mA in it.
How much charge passes a point in the wire in 5 minutes?
- A** 4 C
B 160 C
C 240 C
D 4000 C
- 25** A radio operates at 200 W and the cost of 1 kWh of electricity is 25 cents.
What is the cost of electricity when using this radio for 8 hours?
- A** \$0.40 **B** \$4.40
C \$40.00 **D** \$400

[Turn Over



SPRINGFIELD SECONDARY SCHOOL
End-Of-Year Examination 2021

STUDENT
NAME

CLASS

S		-	
---	--	---	--

INDEX
NUMBER

--	--

SCIENCE
SECONDARY 2 EXPRESS
 Paper 2

5 October 2021
Papers 1 and 2: 1 hour 30 minutes

Candidates answer on the question paper.
 No Additional Materials are required.

READ THESE INSTRUCTIONS FIRST

Write your class, index number and name on all the work you hand in.
 Write in dark blue or black pen on both sides of the paper.
 You may use an HB pencil for any diagrams or graphs.
 Do not use staples, paper clips, glue or correction fluid.

Answer **all** questions in Section A and Section B.
 The use of an approved scientific calculator is expected, where appropriate.
 In calculations, you should show all the steps in your working, giving your answer at each stage.
 A copy of the periodic table is printed on page 10.

The number of marks is given in brackets [] at the end of each question of part question.

For Examiner's Use		
Paper 1		/25
Paper 2	Section A	/20
	Section B	/30
Total		/75

Do not turn over this question paper until you are told to do so.

This question paper consists of **10** printed pages.

[Turn Over

Section A [20 marks]

Answer **all** the questions in the spaces provided.

- 1 Fig. 1.1 shows a bottle that is filled with water. A cap is put on the bottle and it is turned upside down. There is no air inside the bottle.

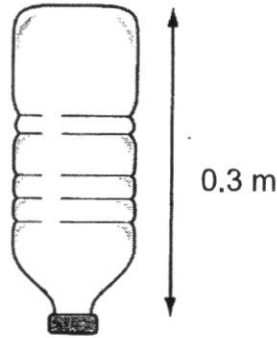

Fig. 1.1

- (a) Define *pressure*.

.....
[1]

- (b) The water exerts a pressure of 4000 Pa on the cap. The area of the cap in contact with the water is 0.00035 m^2 .

Calculate the force exerted on the cap by the water. State its unit.

force = [2]

2 An archer fires an arrow vertically upward into the air as shown in the Fig. 2.1.

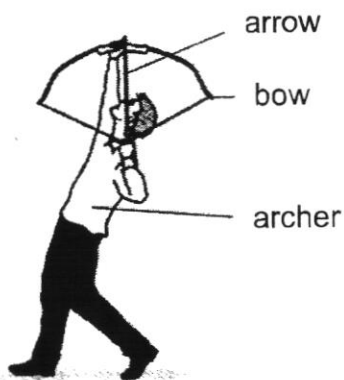

Fig. 2.1

The string of the bow is pulled back for a distance of 0.6 m, using an average force of 120 N. The arrow has a mass of 0.2 kg. All the energy stored in the bow is assumed to be transferred to the arrow when the string is released. Ignore any effect of friction and take gravitational field strength = 10 N/kg.

(a) State the *Law of Conservation of Energy*.

.....
[1]

(b) Calculate the work done in pulling back the string of the bow.

work done = J [2]

(c) State the kinetic energy gained by the arrow when it is released.

kinetic energy = J [1]

(d) Calculate the speed of the arrow when it leaves the bow.

speed = m/s [2]

[Turn Over

4

- 3 Fig. 3.1 shows four atomic structures of particles P, Q, R and S.

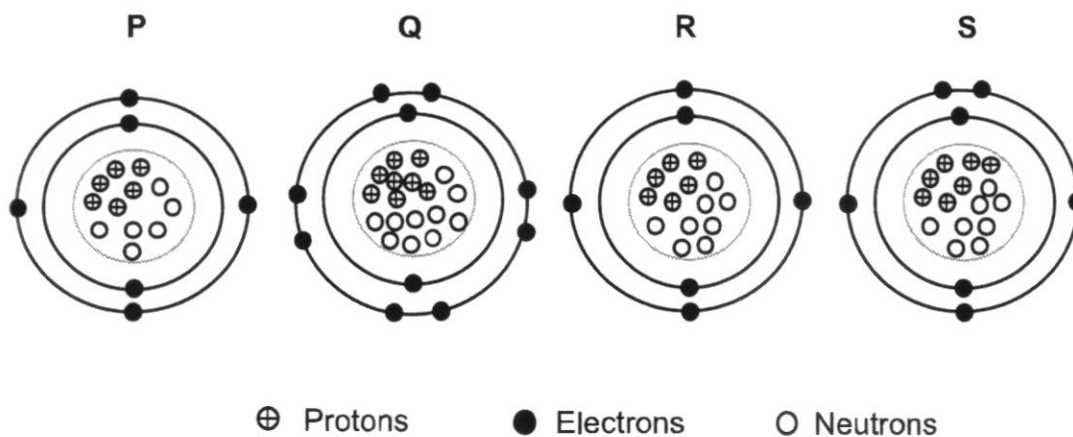

Fig. 3.1

- (a) (i) Explain what is meant by the term *isotopes*.

.....
[1]

- (ii) From Fig. 3.1, identify a pair which are isotopes.

.....[1]

- (b) In Fig. 3.1, one of the particles is **not** electrically neutral.

Name the particle and explain why it is not electrically neutral.

.....
[2]

- 4 The table below shows the melting point and boiling point of some substances.

	melting point/ °C	boiling point/ °C
Hydrogen	-259	-253
Helium	-272	-269
Iron	1535	2750
Oxygen	-219	-183
Carbon monoxide	-205	-192
Magnesium	650	1090

- (a) From the table, name the substance which is **not** an element.
[1]
- (b) From the table, list **one** substance where its atom has **less than** three valence electrons.
[1]
- (c) Planet Uranus, has an average atmospheric temperature of $-195\text{ }^{\circ}\text{C}$.
 If all the substances in the table are present in Uranus, list the substance(s) which is/are in the gaseous state.
[1]

- 5 Two plane mirrors, **AB** and **BC** are placed at an angle as shown in Fig. 5.1. The object, **O** is in between the two mirrors and the observer's eye is away at a distance from **O**.

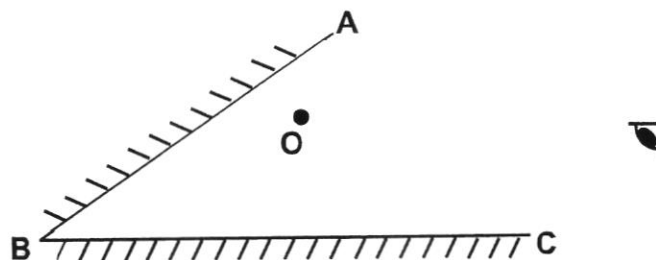

Fig. 5.1

- (a) Locate and label '**P**', the image of the object, in the plane mirror **AB**. [1]
- (b) Locate and label '**Q**', the image of the object, in the plane mirror **BC**. [1]
- (c) Draw a complete **single** ray diagram to show how the eye is able to see **Q** and its corresponding incident ray on the diagram in the plane mirror **BC**. [2]

[Turn Over

Section B [30 marks]

Answer **all** the questions in the spaces provided.

- 6 The flowchart in Fig. 6.1 shows a series of chemical reactions involving acid **A**.

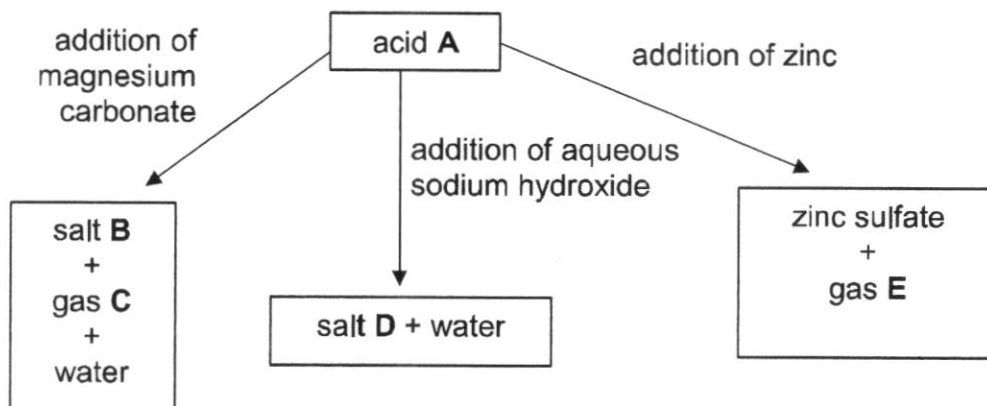

Fig. 6.1

- (a) Identify **A**, **B**, **C**, **D** and **E**.

A: **B**:

C: **D**:

E: [5]

- (b) There is no visible reaction when acid **A** reacts with aqueous sodium hydroxide. Suggest how a student can test if a reaction has occurred.

.....

 [2]

- (c) Describe a test to identify the gas **E** produced and the observation made.

test:

 observation:.....
 [2]

- (d) Write a word equation to show how acid **A** reacts with zinc.

.....
 [1]

7 John heats up some pure water in a metal pan as shown in Fig. 7.1.

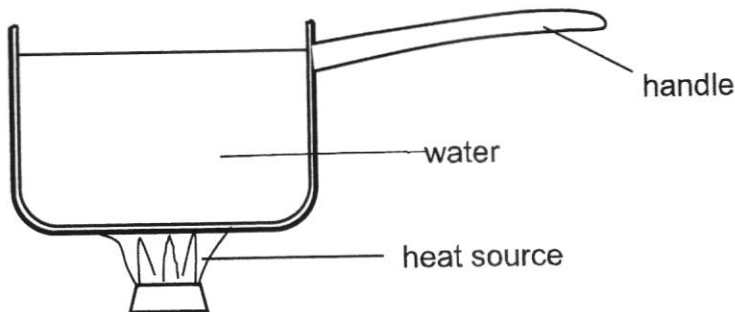

Fig. 7.1

(a) Name the process how heat is transferred through the base of the metal pan.

..... [1]

(b) (i) On Fig. 7.1, draw the movement of water when it is heated. [1]

(ii) Explain the movement of water in (b)(i).

.....

 [3]

(c) Suggest and explain a suitable material for the handle.

.....
 [2]

(d) The pan has a polished and silvery metallic surface.
 Explain how this feature minimises heat loss from the metal pan.

.....
 [1]

(e) After heating for some time, the water remains at a constant temperature of 100 °C. John noticed that the volume of water in the pan decreases. He concludes that water is lost from the pan by evaporation only.

State and explain whether his conclusion is correct.

.....
 [2]

[Turn Over

8

- 8 (a) Resistors **X** and **Y** are connected in parallel to a variable d.c. (direct current) power supply as shown in the Fig. 8.1. A variable direct current power supply allows the user to adjust the output voltage and current easily.

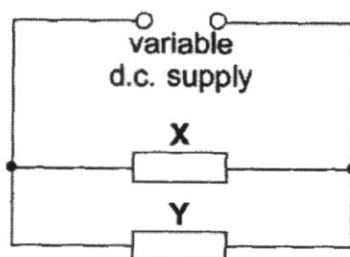

Fig. 8.1

The current in each of the two resistors **X** and **Y** varies with the potential differences (p.d.) across each resistor as shown in Fig. 8.2.

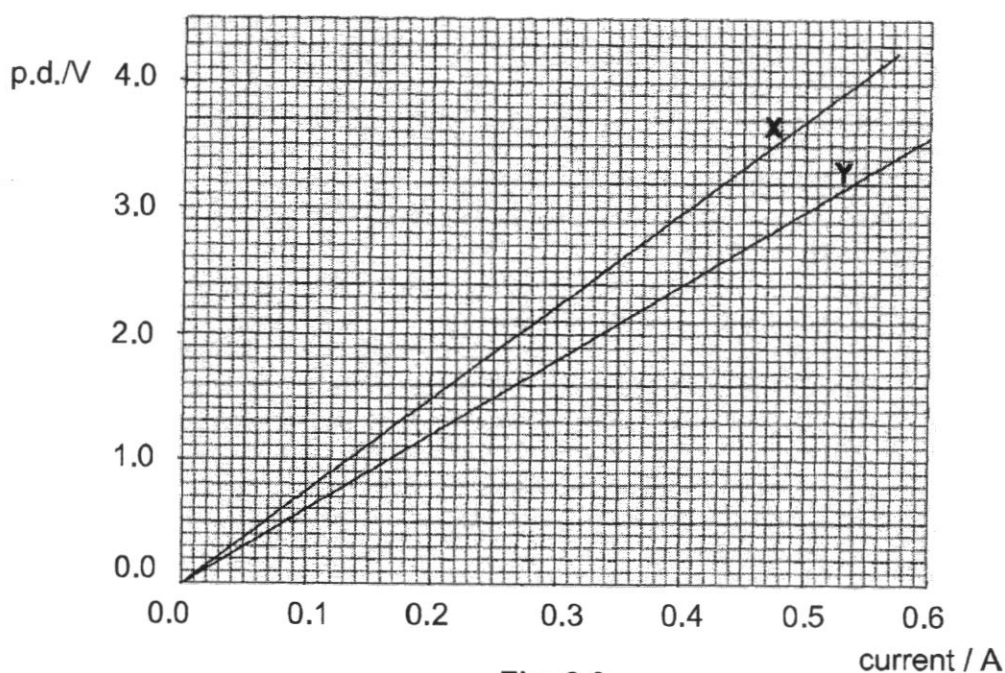

Fig. 8.2

- (i) For an output p.d. of 3.0 V from the d.c. supply, use Fig. 8.2 to determine
 current in **X** :A [1]
 current in **Y** :A [1]
- (ii) Deduce the current in the power supply for the p.d. of 3.0 V.

current = A [1]

- (iii) Hence, calculate the effective resistance in the circuit when the power supply for the p.d is 3.0 V.

resistance = Ω [2]

- (b) Fig 8.3 shows a typical 3-pin wall socket in Singapore. A neutral wire, wire **A**, and wire **B** are connected to the socket as shown. A toaster is connected to this socket using a three-pin plug.

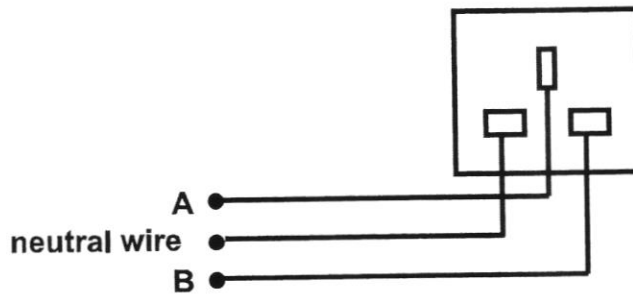

Fig. 8.3

- (i) Name the wires

A :

B : [2]

- (ii) State the function of wire **A**.

..... [1]

- (iii) A fuse is connected in the circuit in Fig. 8.3.

Draw a fuse at the correct position in the circuit.

[1]

- (iv) The current of 4.16 A flows through the toaster when it is switched on. Fuses of ratings 1 A, 5 A and 10 A are available. A fuse of rating 10 A is connected to the toaster.

Explain why it is dangerous to connect a 10 A fuse to the toaster.

..... [1]

[Turn Over



SPRINGFIELD SECONDARY SCHOOL
"BETTER SELF FOR BETTER TOMORROW"
 Lower Secondary Science
 Secondary 2 Express
END-OF-YEAR EXAMINATION (2021)
Marking Scheme

Paper 1 [25 marks]

1	2	3	4	5	6	7	8	9	10
A	C	A	D	A	D	B	D	C	A
11	12	13	14	15	16	17	18	19	20
B	A	C	C	A	C	C	A	D	A
21	22	23	24	25					
C	B	D	C	A					

Paper 2

Section A and B [50 marks]

No	Answer	Marks	Total Marks
1			
(a)	Pressure is defined as force per unit area.	1	3
(b)	$F = P \times A$ $= 4000 \times 0.00035 \text{ m}^2$ $= 1.4 \text{ N}$ [1 mark for answer and 1 mark for correct unit]	1,1	
2			
(a)	Principle of conservation of energy states that <u>energy cannot be created or destroyed</u> , but can be <u>changed from one form to another</u> . The <u>total amount of energy is constant</u> .	1	6
(b)	Work done = force x distance = 120×0.6 = 72 J	1 1	
(c)	72 J	1	
(d)	$k.e = \frac{1}{2} m v^2$ $72 = \frac{1}{2} \times 0.2 \times v^2$ $v^2 = 720$ $v = 26.8 \text{ m/s}$	1 1	

3			
(a)(i)	They are atoms of the <u>same element</u> with <u>same number of protons</u> but <u>different number of neutrons</u> .	1	4
(a)(ii)	P and R	1	
(b)	Q	1	
	The proton numbers are not equal to the number of electrons. Or There are more electrons than protons.	1	
4			
(a)	carbon monoxide	1	3
(b)	Accept hydrogen, iron or magnesium 1 mark for any 1 correct answer	1	
(c)	hydrogen and helium	1	
5			
(a) (b) (c)		4	4
	1 mark for drawing and labelling P		
	1 mark for drawing and labelling Q		
	1 mark for drawing a ray from Q to eye and 1 mark for drawing a ray from O to the mirror BC.		
6			
(a)	A : sulfuric acid B : magnesium sulfate C : carbon dioxide D : sodium sulfate E : hydrogen	1 1 1 1 1	10
(b)	The student can use <u>litmus paper</u> to test for the reaction. Before the reaction, the blue litmus changed from <u>blue</u> to <u>red</u> when placed in acid. After the reaction, the blue litmus paper <u>remains as blue</u> . Or	1 1 Or	

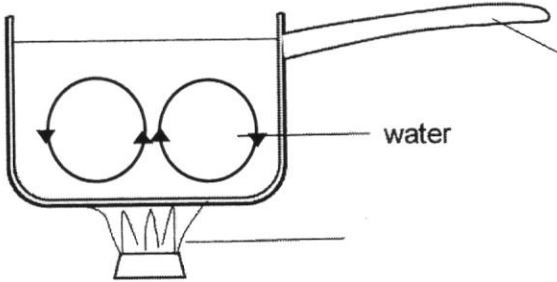
	The student can use <u>Universal Indicator</u> to test, the colour will change from <u>red</u> to <u>green</u> . This will show that a reaction has taken place.	1 1	
(c)	test : Use a lighted splint observation: The gas extinguishes the lighted splint with a 'pop' sound.	1 1	
(d)	zinc + sulfuric acid \longrightarrow zinc sulfate + hydrogen	1	
7			
(a)	conduction	1	
(b)(i)		1	
(b)(ii)	Water at the bottom gets heated up, expands and becomes <u>less dense and rises up</u> . The cooler water at the top is <u>denser and sinks down</u> . This sets up a <u>convection current</u> .	1 1 1	10
(c)	wood / plastic It is a poor conductor of heat.	1 1	
(d)	Silvery metallic surface is a <u>poor emitter/radiator of heat</u> . It can reduce the rate of heat loss to the surrounding by radiation.	1	
(e)	No Water is lost through steam as well, as the temperature has reached a constant temperature of 100 °C. (Only a small amount of water is lost by evaporation since evaporation only takes place at the surface of water)	1 1	
8			
(a)(i)	X : accept 0.40 and 0.41 Y : accept 0.50 to 0.52	1 1	10
(a)(ii)	$0.4 + 0.52 = 0.92$ Allow e.c.f.	1	
(a)(iii)	$R = V/I = 3/0.92$ $= 3.26$	1 1	
(b)(i)	A : Earth wire	1	
	B : Live wire	1	
(b)(ii)	If the live wire touches the metal casing, current will flow to the earth wire to the ground. This prevents the user from getting	1	

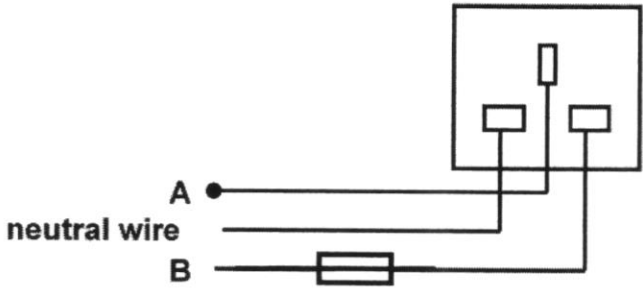
	an electric shock.		
(b)(iii)		1	
(b)(iv)	It is dangerous, as large current will be allowed to enter the toaster which can cause fire.	1	



SPRINGFIELD SECONDARY SCHOOL
End-Of-Year Examination 2021

STUDENT
NAME

CLASS

S		-	
---	--	---	--

INDEX
NUMBER

--	--

SCIENCE
SECONDARY 2 EXPRESS
 Paper 1 Multiple Choice

5 October 2021
Papers 1 and 2: 1 hour 30 minutes

Additional Materials: Multiple Choice Answer Sheet

READ THESE INSTRUCTIONS FIRST

Write in soft pencil.

Do not use staples, paper clips, glue or correction fluid.

Write your name, class and index number on the Answer Sheet in the spaces provided.

There are **twenty-five** questions on this paper. Answer **all** questions. For each question, there are four possible answers **A, B, C** and **D**.

Choose the **one** you consider correct and record your choice in **soft pencil** on the separate Answer Sheet.

Read the instructions on the Answer Sheet very carefully.

Each correct answer will score one mark. A mark will not be deducted for a wrong answer.

Any rough working should be done in this booklet.

A copy of the Periodic Table is printed on page 12.

The use of an approved calculator is expected where appropriate.

Do not turn over this question paper until you are told to do so.

This question paper consists of 12 printed pages.

[Turn Over

2

- 1 An astronaut in his spacesuit has a mass of 75 kg on Earth. He can jump 15 cm off the surface of the Earth. When he is on the Moon, he can jump higher than 15 cm.

Which of the following descriptions is correct?

- A His mass is the same on the Moon as on Earth.
- B His mass is smaller on the Moon than on Earth.
- C His weight is the same on the Moon as on Earth.
- D His weight is greater on the Moon than on Earth.

- 2 The figure shows forces acting on a body.



What is the resultant force acting on the body?

- A 1 N to the left
 - B 2 N to the right
 - C 4 N to the left
 - D 24 N to the right
- 3 In which of the following positions will a person exert the greatest pressure on the ground?
- A The person does a handstand on one of his hands.
 - B The person lies flat on his back.
 - C The person sits cross-legged on the floor.
 - D The person stands on both legs.

- 4 Two different blocks of metal, **X** and **Y**, hang from spring balances as shown below.

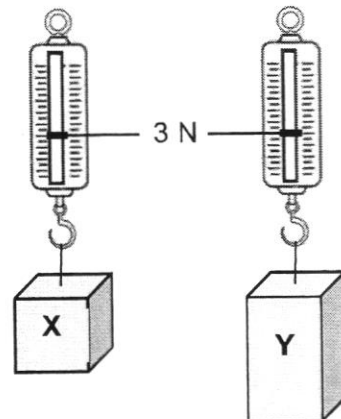

Which of the following statements about metals **X** and **Y** is correct?

- A They have different volume and different weight.
 - B They have different density and different mass.
 - C They have the same mass but different weight.
 - D They have the same weight but different density.
- 5 A man lifts 20 bricks, each weighing 6N.
- What other piece of information is needed to calculate the work done in lifting the bricks?
- A the height he lifts the bricks
 - B the mass of the bricks
 - C the time taken to lift the bricks
 - D the volume of the bricks
- 6 Louis lifts some boxes of identical weight from the ground onto a lorry. In the morning, it takes him 3 s to lift each box. Later in the day, it takes him 2 s.
- Which statement is correct?
- A Later in the day, less work is done in lifting each box.
 - B Later in the day, more work is done in lifting each box.
 - C Later in the day, less power is developed in lifting each box.
 - D Later in the day, more power is developed in lifting each box.

[Turn Over

- 7 The sum of the gravitational potential energy and kinetic energy of an object falling freely under gravity is called its mechanical energy.

Assuming that air resistance is negligible, which of the following best represents the changes in the different energies when the object is falling freely under gravity?

	gravitational potential energy	kinetic energy	mechanical energy
A	decreases	increases	increases
B	decreases	increases	remains constant
C	increases	decreases	decreases
D	increases	decreases	remains constant

- 8 Equal volumes of alcohol and water are added into a beaker.

Which statement explains why the total volume of the mixture is less than the sum of the two volumes added up?

- A** The particles are always in constant and random motion.
- B** The particles are arranged in an orderly manner.
- C** The particles can be compressed because they are far apart.
- D** The particles fill up the spaces between each other.
- 9 Which of the following processes involves the weakening of forces of attraction between the particles?
- A** copper(II) sulfate solution crystallises into copper(II) sulfate crystals
- B** morning dew droplets forming on grass
- C** rock sugar melts in a cup
- D** water freezes to ice

- 10** A substance can exist in three different states: solid, liquid or gas.
Each statement below describes a process which involves a change of state.

process **X**: Molecules start to move further away from each other at high speeds in random directions.

process **Y**: Molecules stop moving throughout the substance and just vibrate about fixed positions.

Which process do these statements describe?

	process X	process Y
A	boiling	freezing
B	condensation	boiling
C	freezing	boiling
D	melting	condensation

- 11** An element, **X**, has p protons and n neutrons.

Which row gives the possible number of subatomic particles in a positive ion of **X**?

	number of protons	number of neutrons	number of electrons
A	p	$n + 1$	$p - 1$
B	p	n	$p - 1$
C	$p + 1$	$n + 1$	p
D	$p - 1$	$n - 1$	$p + 1$

[Turn Over

- 12 The table shows information about particles X and Y.

particle	number of protons	number of neutrons	electronic structure
X	12	12	2,8
Y	20	20	2,8,8

Which statement is correct for both X and Y?

- A They are atoms of metals.
 B They are atoms of noble gases.
 C They are isotopes of the same element.
 D They are positive ions.
- 13 The diagram shows the arrangement of electrons in an ion of an element with a charge of -1 .

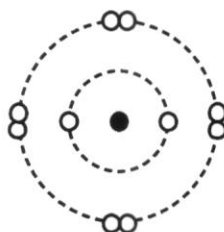

Which group and period does the atom of this element belong to in the Periodic Table?

	group	period
A	I	2
B	I	3
C	VII	2
D	VII	3

- 14 The graph shows how the pH changes in a reaction between an acid and an alkali.

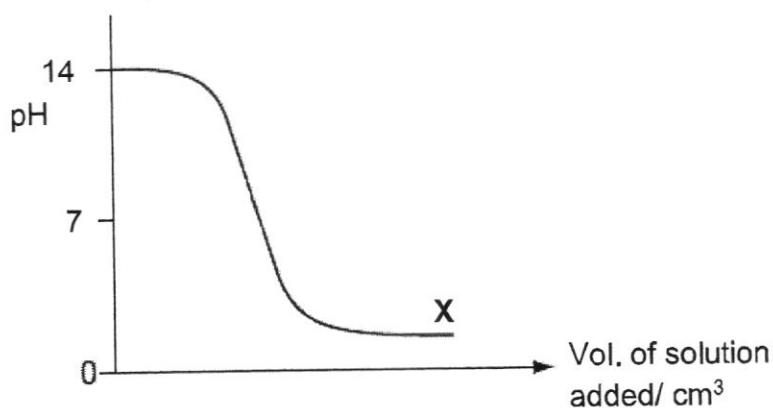

Which of the following statement(s) could be deduced from the graph?

- | | |
|---|--|
| 1 | A gas is produced at part X of the graph. |
| 2 | An acid is added to a fixed volume of an alkali. |
| 3 | Salt and water are produced at part X of the graph. |
- | | |
|-----------------------|-----------------------|
| A 1 and 3 only | B 1 and 2 only |
| C 2 and 3 only | D 1, 2 and 3 |

- 15 A student would like to coat a spoon with a layer of copper metal.

Which of the following is the correct set-up for this electroplating process?

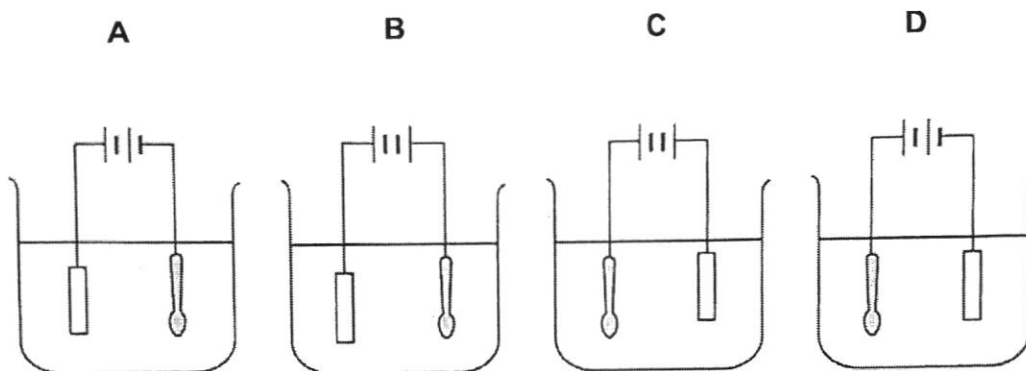

- 16 Which statement describes an alkali correctly?

- | | |
|----------|--|
| A | A strong alkali has a low pH. |
| B | A weak alkali has sour taste. |
| C | Alkali is a base that is soluble in water. |
| D | Alkali is not corrosive. |

[Turn Over

- 17 The diagram below shows the colour range of three pH indicators, methyl orange, bromothymol blue and phenolphthalein.

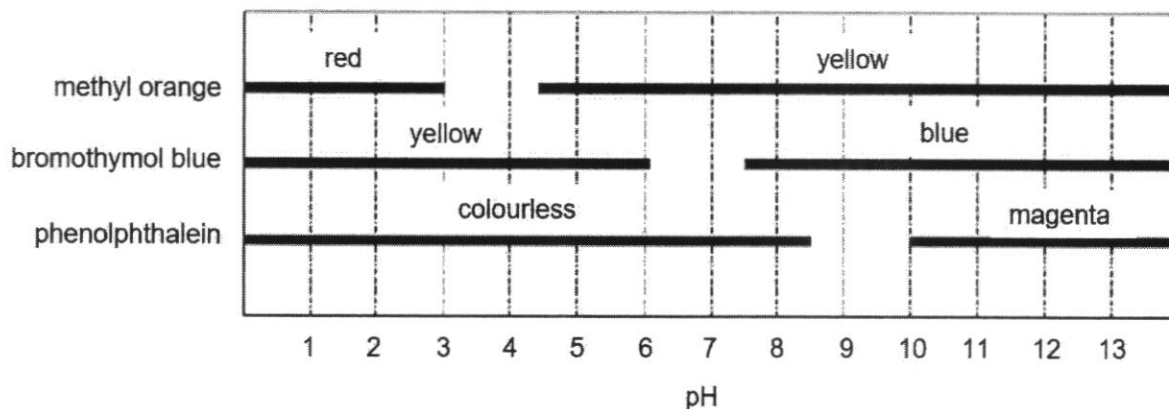

When added separately to solution X, methyl orange is yellow, bromothymol blue is blue and phenolphthalein is colourless.

What is the pH range of solution X?

- A 4.5 to 6.0 B 6.0 to 7.5
C 7.5 to 8.5 D 8.5 to 10.0
- 18 A card with the word 'PENCIL' is placed perpendicular to the plane mirror as shown in the diagram.

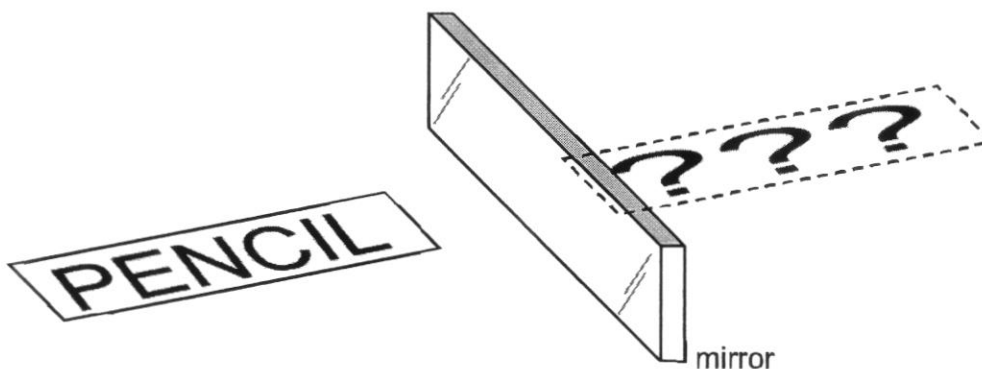

How would the image in the mirror appear?

- A JIƆIƆƆP
B PENCIL
C PEJICM
D JIƆNEP

19 A person stands at point X as shown in the diagram below.

Which of the pins (1, 2, 3, 4 and 5) can the person see in the mirror?

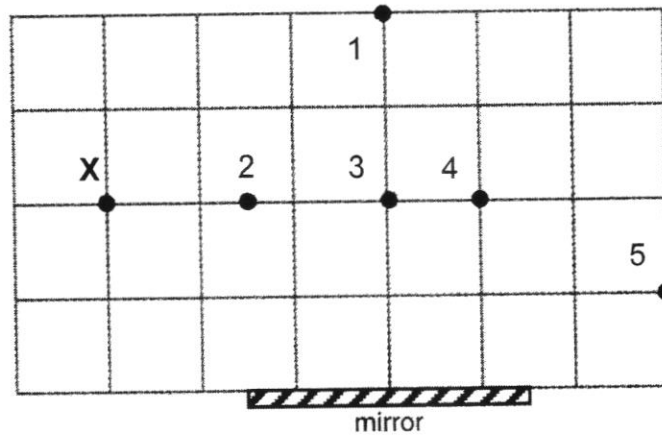

- A 1 and 3 only
- B 3 and 4 only
- C 2, 3 and 5 only
- D 3, 4 and 5 only
- 20 Which of the following are the characteristics of an image formed by a plane mirror and a convex mirror?

	image formed by plane mirror	image formed by convex mirror
A	same size	diminished
B	same size	inverted
C	upright	enlarged
D	virtual	real

[Turn Over



SPRINGFIELD SECONDARY SCHOOL
End-Of-Year Examination 2021

STUDENT
NAME

CLASS

S		-	
---	--	---	--

INDEX
NUMBER

--	--

SCIENCE
SECONDARY 2 EXPRESS
 Paper 2

5 October 2021
Papers 1 and 2: 1 hour 30 minutes

Candidates answer on the question paper.
 No Additional Materials are required.

READ THESE INSTRUCTIONS FIRST

Write your class, index number and name on all the work you hand in.
 Write in dark blue or black pen on both sides of the paper.
 You may use an HB pencil for any diagrams or graphs.
 Do not use staples, paper clips, glue or correction fluid.

Answer **all** questions in Section A and Section B.
 The use of an approved scientific calculator is expected, where appropriate.
 In calculations, you should show all the steps in your working, giving your answer at each stage.
 A copy of the periodic table is printed on page 10.

The number of marks is given in brackets [] at the end of each question of part question.

For Examiner's Use		
Paper 1		/25
Paper 2	Section A	/20
	Section B	/30
Total		/75

Do not turn over this question paper until you are told to do so.

This question paper consists of 10 printed pages.

[Turn Over

Section A [20 marks]

Answer **all** the questions in the spaces provided.

- 1 Fig. 1.1 shows a bottle that is filled with water. A cap is put on the bottle and it is turned upside down. There is no air inside the bottle.

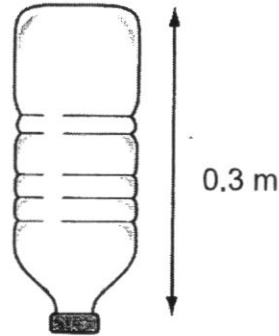

Fig. 1.1

- (a) Define *pressure*.

.....
[1]

- (b) The water exerts a pressure of 4000 Pa on the cap. The area of the cap in contact with the water is 0.00035 m^2 .

Calculate the force exerted on the cap by the water. State its unit.

force = [2]

- 2 An archer fires an arrow vertically upward into the air as shown in the Fig. 2.1.

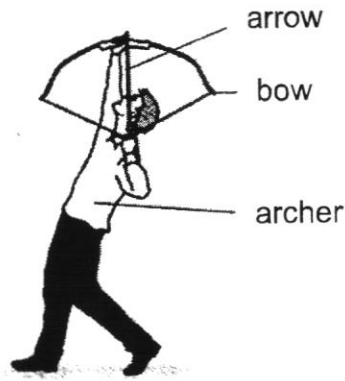

Fig. 2.1

The string of the bow is pulled back for a distance of 0.6 m, using an average force of 120 N. The arrow has a mass of 0.2 kg. All the energy stored in the bow is assumed to be transferred to the arrow when the string is released. Ignore any effect of friction and take gravitational field strength = 10 N/kg.

- (a) State the *Law of Conservation of Energy*.

.....
[1]

- (b) Calculate the work done in pulling back the string of the bow.

work done = J [2]

- (c) State the kinetic energy gained by the arrow when it is released.

kinetic energy = J [1]

- (d) Calculate the speed of the arrow when it leaves the bow.

speed = m/s [2]

[Turn Over

- 3 Fig. 3.1 shows four atomic structures of particles P, Q, R and S.

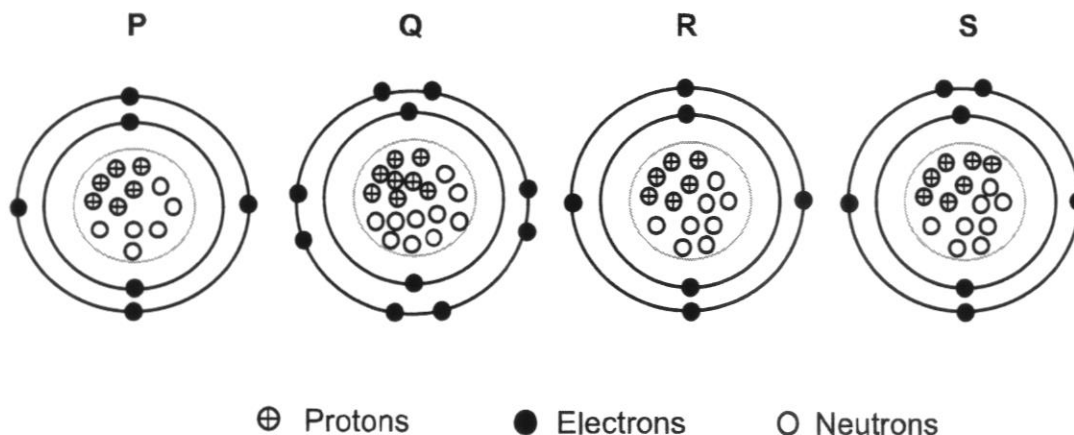

Fig. 3.1

- (a) (i) Explain what is meant by the term *isotopes*.
-
-[1]
- (ii) From Fig. 3.1, identify a pair which are isotopes.
-[1]
- (b) In Fig. 3.1, one of the particles is **not** electrically neutral.
- Name the particle and explain why it is not electrically neutral.
-
-[2]

- 4 The table below shows the melting point and boiling point of some substances.

	melting point/ °C	boiling point/ °C
Hydrogen	-259	-253
Helium	-272	-269
Iron	1535	2750
Oxygen	-219	-183
Carbon monoxide	-205	-192
Magnesium	650	1090

- (a) From the table, name the substance which is **not** an element.

.....[1]

- (b) From the table, list **one** substance where its atom has **less than** three valence electrons.

.....[1]

- (c) Planet Uranus, has an average atmospheric temperature of $-195\text{ }^{\circ}\text{C}$. If all the substances in the table are present in Uranus, list the substance(s) which is/are in the gaseous state.

.....[1]

- 5 Two plane mirrors, **AB** and **BC** are placed at an angle as shown in Fig. 5.1. The object, **O** is in between the two mirrors and the observer's eye is away at a distance from **O**.

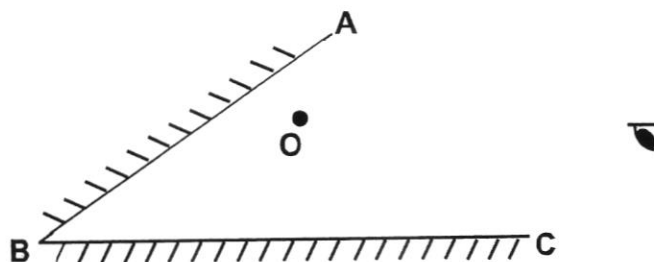

Fig. 5.1

- (a) Locate and label '**P**', the image of the object, in the plane mirror **AB**. [1]
- (b) Locate and label '**Q**', the image of the object, in the plane mirror **BC**. [1]
- (c) Draw a complete **single** ray diagram to show how the eye is able to see **Q** and its corresponding incident ray on the diagram in the plane mirror **BC**. [2]

[Turn Over

Section B [30 marks]

Answer **all** the questions in the spaces provided.

- 6 The flowchart in Fig. 6.1 shows a series of chemical reactions involving acid **A**.

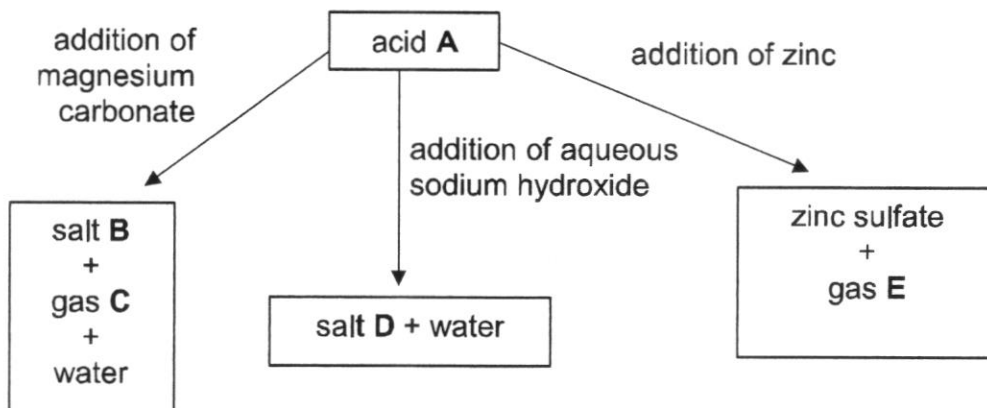

Fig. 6.1

- (a) Identify **A**, **B**, **C**, **D** and **E**.

A: **B**:

C: **D**:

E: [5]

- (b) There is no visible reaction when acid **A** reacts with aqueous sodium hydroxide. Suggest how a student can test if a reaction has occurred.

.....

 [2]

- (c) Describe a test to identify the gas **E** produced and the observation made.

test:

observation:.....

..... [2]

- (d) Write a word equation to show how acid **A** reacts with zinc.

.....
, [1]

7 John heats up some pure water in a metal pan as shown in Fig. 7.1.

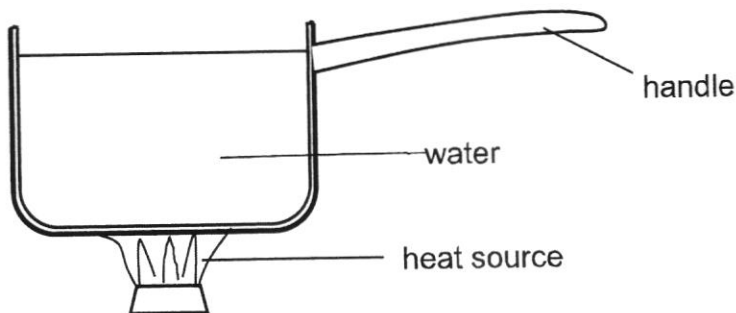

Fig. 7.1

(a) Name the process how heat is transferred through the base of the metal pan.

..... [1]

(b) (i) On Fig. 7.1, draw the movement of water when it is heated. [1]

(ii) Explain the movement of water in (b)(i).

.....

 [3]

(c) Suggest and explain a suitable material for the handle.

.....
 [2]

(d) The pan has a polished and silvery metallic surface.
 Explain how this feature minimises heat loss from the metal pan.

.....
 [1]

(e) After heating for some time, the water remains at a constant temperature of 100 °C. John noticed that the volume of water in the pan decreases. He concludes that water is lost from the pan by evaporation only.

State and explain whether his conclusion is correct.

.....
 [2]

[Turn Over

8

- 8 (a) Resistors **X** and **Y** are connected in parallel to a variable d.c. (direct current) power supply as shown in the Fig. 8.1. A variable direct current power supply allows the user to adjust the output voltage and current easily.

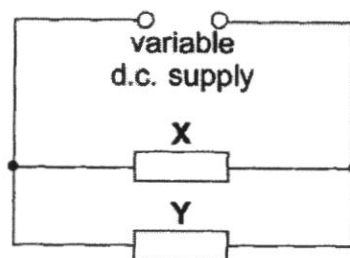

Fig. 8.1

The current in each of the two resistors **X** and **Y** varies with the potential differences (p.d.) across each resistor as shown in Fig. 8.2.

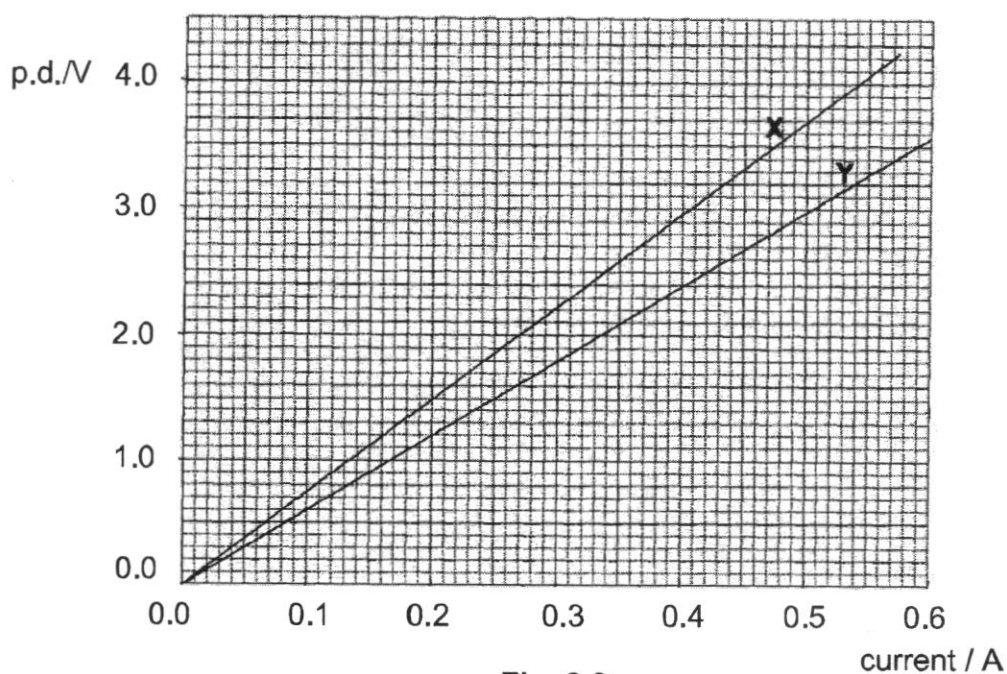

Fig. 8.2

- (i) For an output p.d. of 3.0 V from the d.c. supply, use Fig. 8.2 to determine
 current in **X** :A [1]
 current in **Y** :A [1]
- (ii) Deduce the current in the power supply for the p.d. of 3.0 V.

current = A [1]

- (iii) Hence, calculate the effective resistance in the circuit when the power supply for the p.d is 3.0 V.

resistance = Ω [2]

- (b) Fig 8.3 shows a typical 3-pin wall socket in Singapore. A neutral wire, wire **A**, and wire **B** are connected to the socket as shown. A toaster is connected to this socket using a three-pin plug.

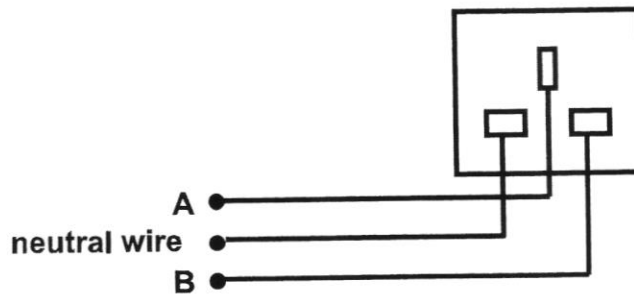

Fig. 8.3

- (i) Name the wires

A :

B : [2]

- (ii) State the function of wire **A**.

.....
 [1]

- (iii) A fuse is connected in the circuit in Fig. 8.3.

Draw a fuse at the correct position in the circuit. [1]

- (iv) The current of 4.16 A flows through the toaster when it is switched on. Fuses of ratings 1 A, 5 A and 10 A are available. A fuse of rating 10 A is connected to the toaster.

Explain why it is dangerous to connect a 10 A fuse to the toaster.

.....
 [1]

[Turn Over



SPRINGFIELD SECONDARY SCHOOL
"BETTER SELF FOR BETTER TOMORROW"
 Lower Secondary Science
 Secondary 2 Express
END-OF-YEAR EXAMINATION (2021)
Marking Scheme

Paper 1 [25 marks]

1	2	3	4	5	6	7	8	9	10
A	C	A	D	A	D	B	D	C	A
11	12	13	14	15	16	17	18	19	20
B	A	C	C	A	C	C	A	D	A
21	22	23	24	25					
C	B	D	C	A					

Paper 2
Section A and B [50 marks]

No	Answer	Marks	Total Marks
1			
(a)	Pressure is defined as force per unit area.	1	3
(b)	$F = P \times A$ $= 4000 \times 0.00035 \text{ m}^2$ $= 1.4 \text{ N}$ [1 mark for answer and 1 mark for correct unit]	1,1	
2			
(a)	Principle of conservation of energy states that <u>energy cannot be created or destroyed</u> , but can be <u>changed from one form to another</u> . The <u>total amount of energy is constant</u> .	1	6
(b)	Work done = force x distance = 120×0.6 = 72 J	1 1	
(c)	72 J	1	
(d)	$k.e = \frac{1}{2} m v^2$ $72 = \frac{1}{2} \times 0.2 \times v^2$ $v^2 = 720$ $v = 26.8 \text{ m/s}$	1 1	

3			
(a)(i)	They are atoms of the <u>same element</u> with <u>same number of protons</u> but <u>different number of neutrons</u> .	1	4
(a)(ii)	P and R	1	
(b)	Q The proton numbers are not equal to the number of electrons. Or There are more electrons than protons.	1	
4			
(a)	carbon monoxide	1	3
(b)	Accept hydrogen, iron or magnesium 1 mark for any 1 correct answer	1	
(c)	hydrogen and helium	1	
5			
(a) (b) (c)	<p>The diagram shows a horizontal line representing a mirror BC. A point O is marked on the mirror. A point P is located above the mirror, and a point Q is located below it. A dashed line connects P and O, and another dashed line connects Q and O. A ray from P reflects off the mirror at point A. A ray from Q reflects off the mirror at point C. An eye is shown to the right of the mirror. Labels include P, O, Q, A, B, C, and 5a [1], 5b [1], 5c [1].</p>	4	4
	1 mark for drawing and labelling P		
	1 mark for drawing and labelling Q		
	1 mark for drawing a ray from Q to eye and 1 mark for drawing a ray from O to the mirror BC.		
6			
(a)	A : sulfuric acid B : magnesium sulfate C : carbon dioxide D : sodium sulfate E : hydrogen	1 1 1 1 1	10
(b)	The student can use <u>litmus paper to test</u> for the reaction. Before the reaction, the <u>blue litmus</u> changed from <u>blue to red</u> when placed in acid. After the reaction, the blue litmus paper <u>remains as blue</u> . Or	1 1 Or	

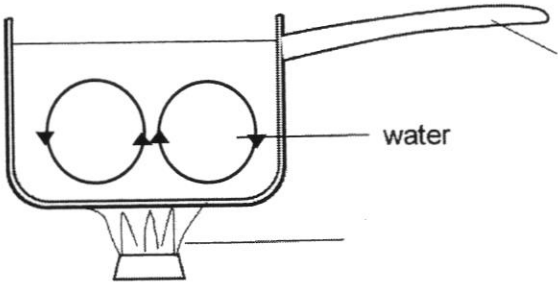
	The student can use <u>Universal Indicator</u> to test, the colour will change from <u>red to green</u> . This will show that a reaction has taken place.	1 1	
(c)	test : Use a lighted splint observation: The gas extinguishes the lighted splint with a 'pop' sound.	1 1	
(d)	zinc + sulfuric acid \longrightarrow zinc sulfate + hydrogen	1	
7			
(a)	conduction	1	
(b)(i)		1	
(b)(ii)	Water at the bottom gets heated up, expands and becomes <u>less dense and rises up</u> . The cooler water at the top is <u>denser and sinks down</u> . This sets up a <u>convection current</u> .	1 1 1	10
(c)	wood / plastic It is a poor conductor of heat.	1 1	
(d)	Silvery metallic surface is a <u>poor emitter/radiator of heat</u> . It can <u>reduce the rate of heat loss to the surrounding by radiation</u> .	1	
(e)	No Water is lost through steam as well, as the temperature has reached a constant temperature of 100 °C. (Only a small amount of water is lost by evaporation since evaporation only takes place at the surface of water)	1 1	
8			
(a)(i)	X : accept 0.40 and 0.41 Y : accept 0.50 to 0.52	1 1	
(a)(ii)	$0.4 + 0.52 = 0.92$ Allow e.c.f.	1	
(a)(iii)	$R = V/I = 3/0.92$ $= 3.26$	1 1	10
(b)(i)	A : Earth wire B : Live wire	1 1	
(b)(ii)	If the <u>live wire touches the metal casing</u> , current will flow to the earth wire to the ground. <u>This prevents the user from getting</u>	1	

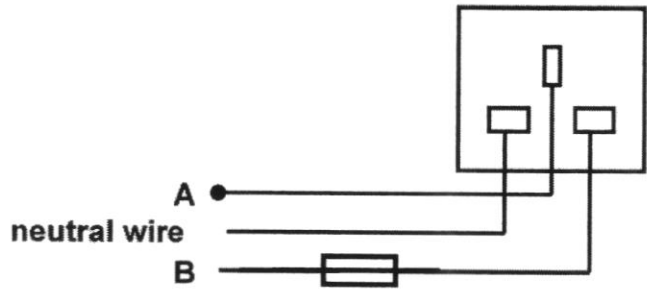
	<u>an electric shock.</u>		
(b)(iii)	 <p>A ● neutral wire B</p>	1	
(b)(iv)	It is dangerous, as large current will be allowed to enter the toaster which can cause fire.	1	