

*Visit*

**FREETESTPAPER.com**

*for more papers*



Website: [freetestpaper.com](http://www.freetestpaper.com)



[Facebook.com/freetestpaper](https://www.facebook.com/freetestpaper)



[Twitter.com/freetestpaper](https://www.twitter.com/freetestpaper)

NAME:

NO:

CLASS:

## ADMIRALTY SECONDARY SCHOOL



## MID-YEAR EXAMINATION 2022

SUBJECT : Science  
 LEVEL/STREAM : Secondary 2 Express  
 DATE : 13 May 2022  
 TIME : 0750h – 0920h  
 DURATION : 1 hour 30 minutes

**Instructions to candidates:**

Write your name, index number and class on the cover page.

Write in dark blue or black pen.

Do not use staples, paper clips, highlighters, glue or correction fluid.

**Section A:** Multiple Choice Questions [20 marks]

Answer all questions in the OTAS provided.

**Section B:** Short Answer Questions [40 marks]

Answer all questions. Write your answers in the spaces provided in the question paper.

**Section C:** Structured Questions [20 marks]

Answer any two out of three questions. Write your answers in the spaces provided in the question paper.

Submit the question paper and OTAS separately.

Candidates are reminded that all quantitative answers should include appropriate units.

The use of an approved scientific calculator is expected, where appropriate.

The number of marks is given in brackets [ ] at the end of each question or part question.

A copy of the Periodic Table is provided on the last page of this paper.

For Examiner's Use	
<b>Section A</b>	/ 20
<b>Section B</b>	/ 40
<b>Section C</b>	/ 20
<b>Total</b>	/ 80

**DO NOT TURN OVER THIS PAPER UNTIL YOU ARE TOLD TO DO SO.**

This question paper consists of **20** printed pages including this cover page.





## 4

- 8 The table below gives information about three pH indicators. Each indicator only shows two colours. The pH in which each indicator changes from one colour to another is shown in the table.

indicator	colour at pH 1	pH at which colour changes	colour at pH 12
thymol blue	red	3	yellow
congo red	blue	5	red
phenolphthalein	colourless	10	red

Which colours would be obtained when each indicator was added separately to pure water?

	thymol blue	congo red	phenolphthalein
<b>A</b>	red	blue	colourless
<b>B</b>	red	blue	red
<b>C</b>	yellow	red	colourless
<b>D</b>	yellow	red	red

- 9 Which of the following forms of energy is found in the food we eat?
- A** chemical potential energy      **B** gravitational potential energy  
**C** heat energy      **D** light energy
- 10 A block of wood has a mass of 15 kg on Earth. What would be its weight on Earth?
- A** 5 N      **B** 15 N      **C** 75 N      **D** 150 N
- 11 Which statement is true about gravitational force?
- A** Earth is the only planet that has gravitational force.  
**B** A moving object has no gravitational force acting on it.  
**C** Gravitational force is present only when two surfaces touch each other.  
**D** The gravitational force acting on Earth is larger than the gravitational force acting on the Moon.

- 12 Which of the following is true about energy?
- A Energy can be created and destroyed.  
 B Energy cannot be created nor destroyed.  
 C Energy can be created but cannot be destroyed.  
 D Energy cannot be created but can be destroyed.
- 13 Which of the underlined object does **not** have kinetic energy?
- A A ship sailing on the sea.  
 B A ball being thrown upwards.  
 C A box placed at the top of a building.  
 D A man climbing down a flight of stairs.
- 14 An object is at rest on the floor. A person applied a force of 500 N on the object. What is the work done if the object remains at its original position?
- A 0 J                      B 225 J                      C 500 J                      D 1000 J
- 15 Which of the following are part of the biotic environment?
- I temperature  
 II mutualism  
 III parasitism
- A I and II only                      B I and III only  
 C II and III only                      D I, II and III
- 16 The diagram below shows a food chain.



Which of the following organisms could represent X, Y and Z?

	X	Y	Z
A	eagle	earthworm	chicken
B	chicken	grasshopper	eagle
C	earthworm	eagle	chicken
D	grasshopper	chicken	eagle

6

17 Earthworms live in the soil. Which of the following physical factors is **least** likely to affect the habitat of earthworms?

- A light                      B oxygen                      C pH level                      D water

18 Which of the following is an example of sustainable living?

- A Walking instead of taking the bus for a very short journey.  
 B Buying coffee powder from a source that pays coffee farmers poorly.  
 C Lowering the temperature to 18 °C whenever the air-conditioner is used.  
 D Buying palm oil from a source that openly burns trees to clear land for farming.

19 The following shows a food chain.

tree → caterpillar → bird

Which of the following is true?

- A Energy flows through parasitism.  
 B Energy flows from the bird to the tree.  
 C Energy enters the food chain through the tree.  
 D Energy increases in each stage of the food chain.

20 Which part of the cycle, **A**, **B**, **C** or **D**, represents decomposers?

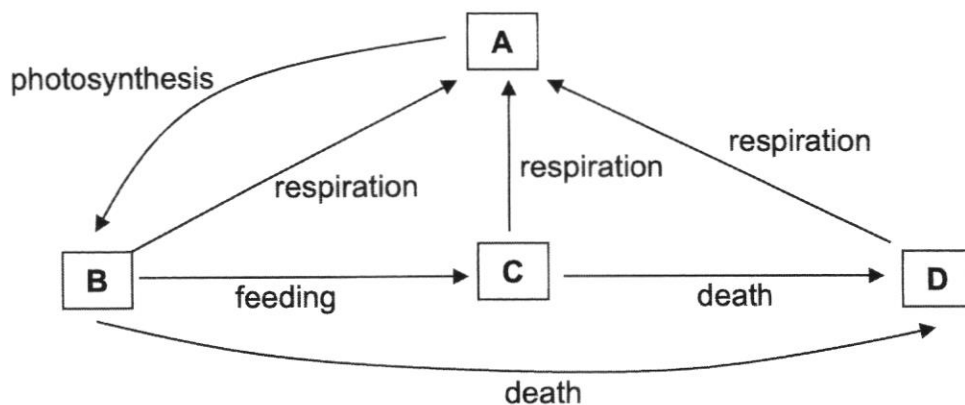

**Section B**  
Answer all questions.

- 1 (a) Identify two main forces that are acting on the stationary ball on the edge of a table as shown in Fig. 1.1.



**Fig. 1.1**

..... [2]

- (b) Classify your answer in (a) as contact force or non-contact force.

contact force	non-contact force

[1]

- (c) The ball is moved 50 cm by a 200 N force as shown in Fig. 1.2.

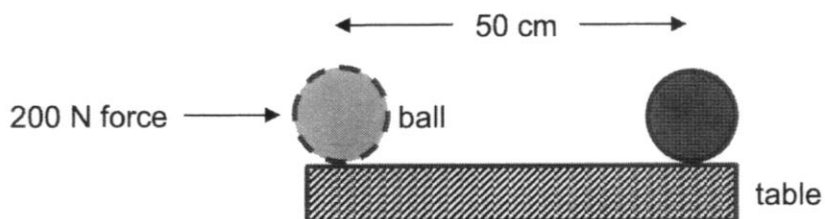

**Fig. 1.2**

Calculate the work done by the force to move the ball.

work done = ..... [3]

8

- 2 Fig. 2.1 shows an electric motor lifting a 2000 N load using electricity. The motor turns anti-clockwise as it lifts the load up.

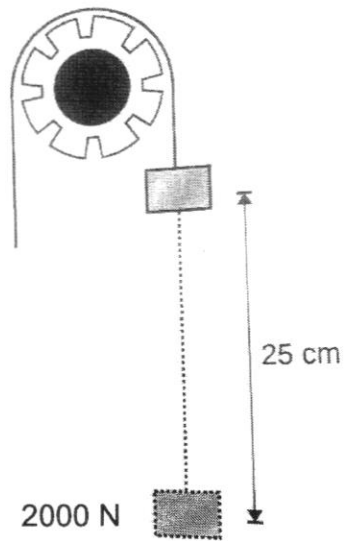

**Fig. 2.1**

State the main conversions of energy that has taken place

- (a) in the motor,

..... [2]

- (b) in the load.

..... [2]

- 3 Fig. 3.1 shows substance A represented by twelve particles. After process X, there are changes to the particles in substance A, as shown in Fig. 3.2.

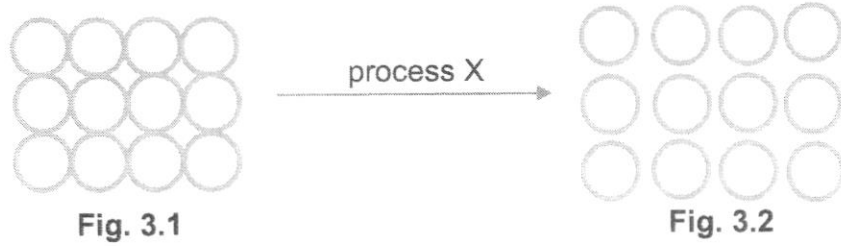

- (a) Describe what has happened to substance A.

..... [1]

- (b) Name process X.

..... [1]

- (c) Process X causes the following phenomenon when substance A is in liquid state, as shown in Fig. 3.3.

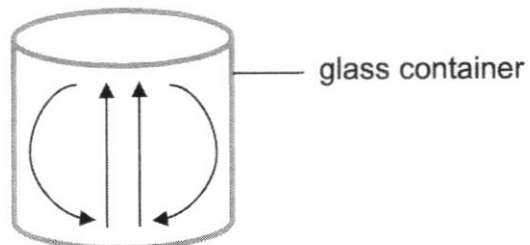

Fig. 3.3

- (i) What phenomenon is shown in Fig. 3.3?

..... [1]

- (ii) State where process X happened in the set-up in Fig. 3.3 and explain how process X leads to your answer in (c)(i).

.....  
.....  
..... [3]

- 4 Fig. 4.1 shows a simple fire alarm that consists of a bimetallic strip, made up of brass and iron. When there is a fire, the bell striker will start striking the bell, activating the fire alarm.

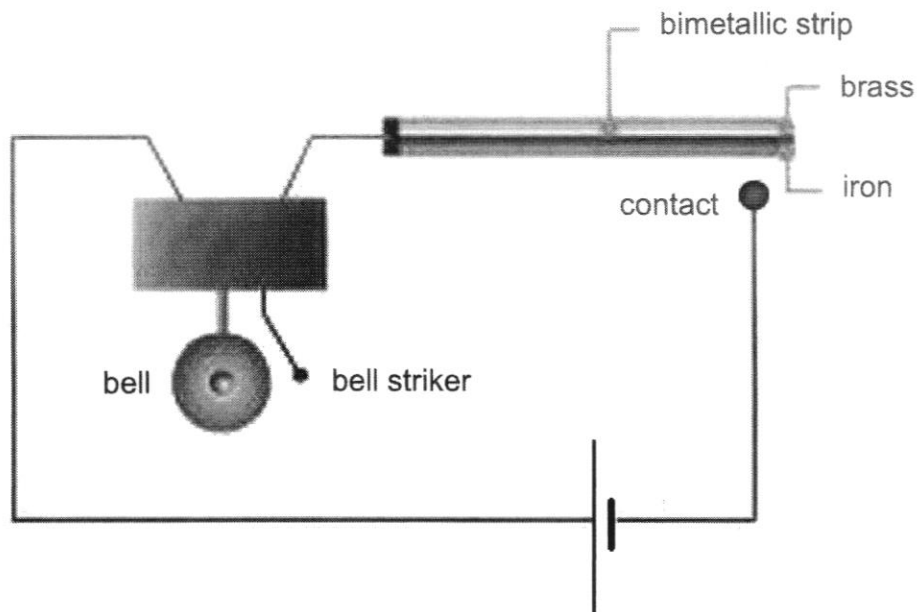

Fig. 4.1

By using your knowledge of bimetallic strip, explain how the simple fire alarm in Fig. 4.1 works.

.....

.....

.....

.....

.....

.....

.....

..... [4]

- 5 One common source of fuel is natural gas, which is made up of mainly methane (CH<sub>4</sub>). During the combustion of methane, water vapour and another product B is formed. Fig. 5.1 shows the molecular representation of the combustion of methane.

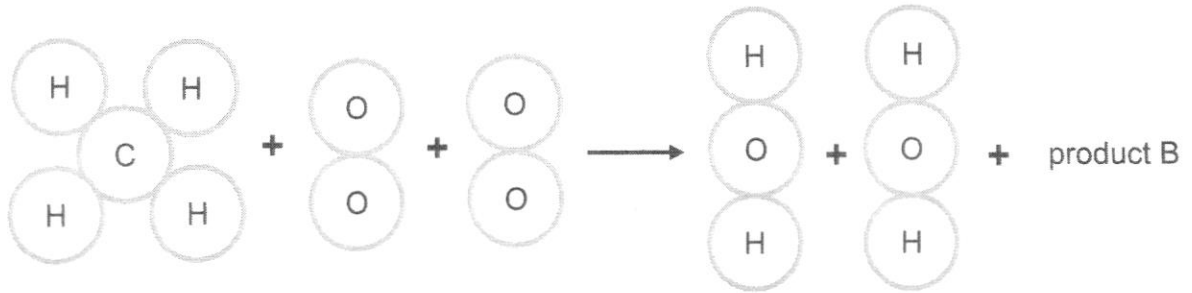
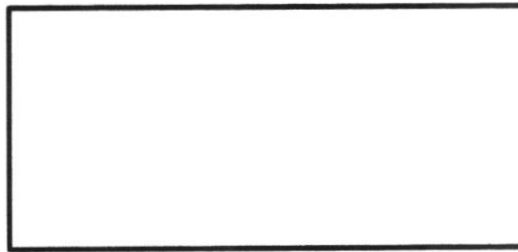

Fig. 5.1

- (a) State the condition needed for combustion of fuel to take place that is missing in Fig. 5.1.

..... [1]

- (b) In the box below, draw a molecular representation of product B.



[1]

- (c) When 32 g of methane reacts with 128 g of oxygen, 88 g of product B is formed. Calculate the mass of water vapour formed. Explain your calculation.

.....  
 ..... [3]

- (d) State one benefit and one harmful effect of combustion.

.....  
 ..... [2]

(e) Thermal decomposition is another common chemical process that takes place.

(i) Define "thermal decomposition".

.....

..... [1]

(ii) State a similarity between combustion and thermal decomposition.

..... [1]

(iii) The following incomplete word equation represents a thermal decomposition. Complete the word equation by filling in the dotted boxes below using either "+" or "→".

substance P  substance Q  substance R  substance S [1]

6 Fig. 6.1 shows a food chain.



Fig. 6.1

(a) Which class of organism would occupy the trophic level X? Explain your answer.

.....

..... [2]

(b) Only 10% of the energy level is transferred to the next trophic level. What happens to the other 90%?

..... [1]

(c) The energy content of the butterfly is 24500 J.  
Calculate the energy content left in the trophic level Z.

[2]

7 Fig. 7.1 shows the concentration of carbon dioxide in the atmosphere measured in a town in Singapore between 1959 and 2013.

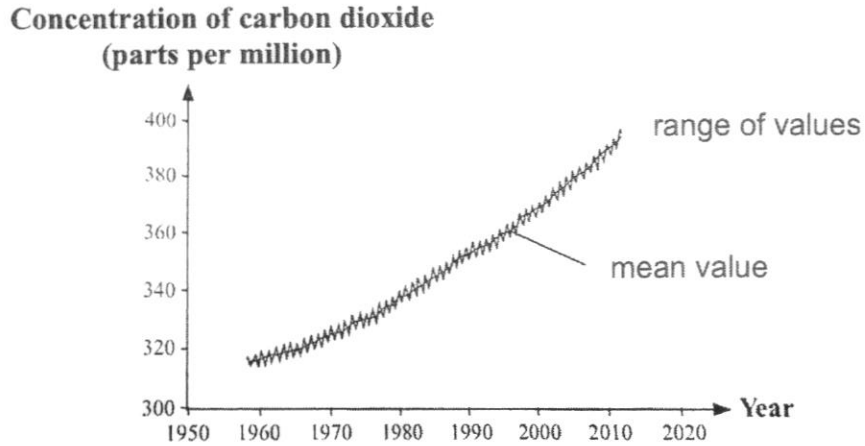

Fig. 7.1

(a) Referring to the graph, state how the concentration of carbon dioxide in the atmosphere has changed over the years.

..... [1]

(b) Suggest two reasons for the change in the concentration of carbon dioxide in the atmosphere.

.....  
..... [2]

(c) Explain how the increase in the concentration of carbon dioxide in the atmosphere affects the ecosystem.

.....  
.....  
..... [2]

**Section C**

Answer any two out of three questions.

- 8 (a) Fig. 8.1 shows an offshore oil drilling rig. It is used to obtain oil and natural gas to meet the demand for energy consumption in the world.



**Fig. 8.1**

- (i) What are oil and natural gas commonly known as?

..... [1]

- (ii) Oil and natural gas are non-renewable. Explain what non-renewable means.

.....  
..... [1]

- (iii) Singapore is encouraging the use of renewable sources of energy. Suggest one renewable energy source that is suitable for use in Singapore and explain why this source is suitable for Singapore.

.....  
.....  
..... [2]

(iv) State an advantage and a disadvantage of using renewable sources of energy and non-renewable sources of energy.

.....  
.....  
.....  
..... [4]

(b) Study nail A and nail B in Fig. 8.2.

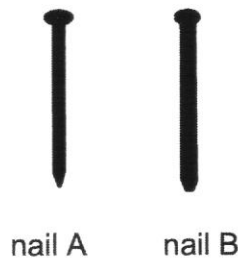

**Fig. 8.2**

The masses of both nails are the same. When the same force is applied to them, nail A can penetrate a wall easier than nail B. Explain why this is so.

.....  
.....  
..... [2]

## 16

- 9 When calcium oxide is added to water in a white container, it produces calcium hydroxide solution. Mixing calcium oxide and water produces heat and causes the water in the white container to heat up. The maximum temperature reached by the water in the white container is 50 °C. Subsequently, the temperature of the water is recorded every minute as shown in Table 9.1.

Time / min	0	1	2	3	4	5	6	7
Temperature / °C	50	48.5	47	45.5	44	42.5	41	39.5

Table 9.1

- (a) On the grid provided on the next page, plot a graph of temperature against time. Mark each point with a cross (×). Draw a best-fit line, taking into account all your [2] plotted points. Label this line "white".

- (b) Predict how the temperature in the white container will change after the 7<sup>th</sup> minute. Explain your answer.

.....

..... [2]

- (c) The experiment is repeated by mixing calcium oxide and water in a black container. The maximum temperature reached by the water is also 50 °C.

- (i) On the same grid provided on the next page, draw a line to suggest how the temperature in the black container will change from t = 0 min to t = 7 min. Label this line "black". [1]

- (ii) Explain your answer in (c)(i).

.....

..... [2]

- (d) Write a word equation to represent the mixing of calcium oxide and water.

..... [1]

- (e) Is the mixing of calcium oxide and water a physical or chemical change? Explain your answer using two evidence from the passage.

.....

..... [2]

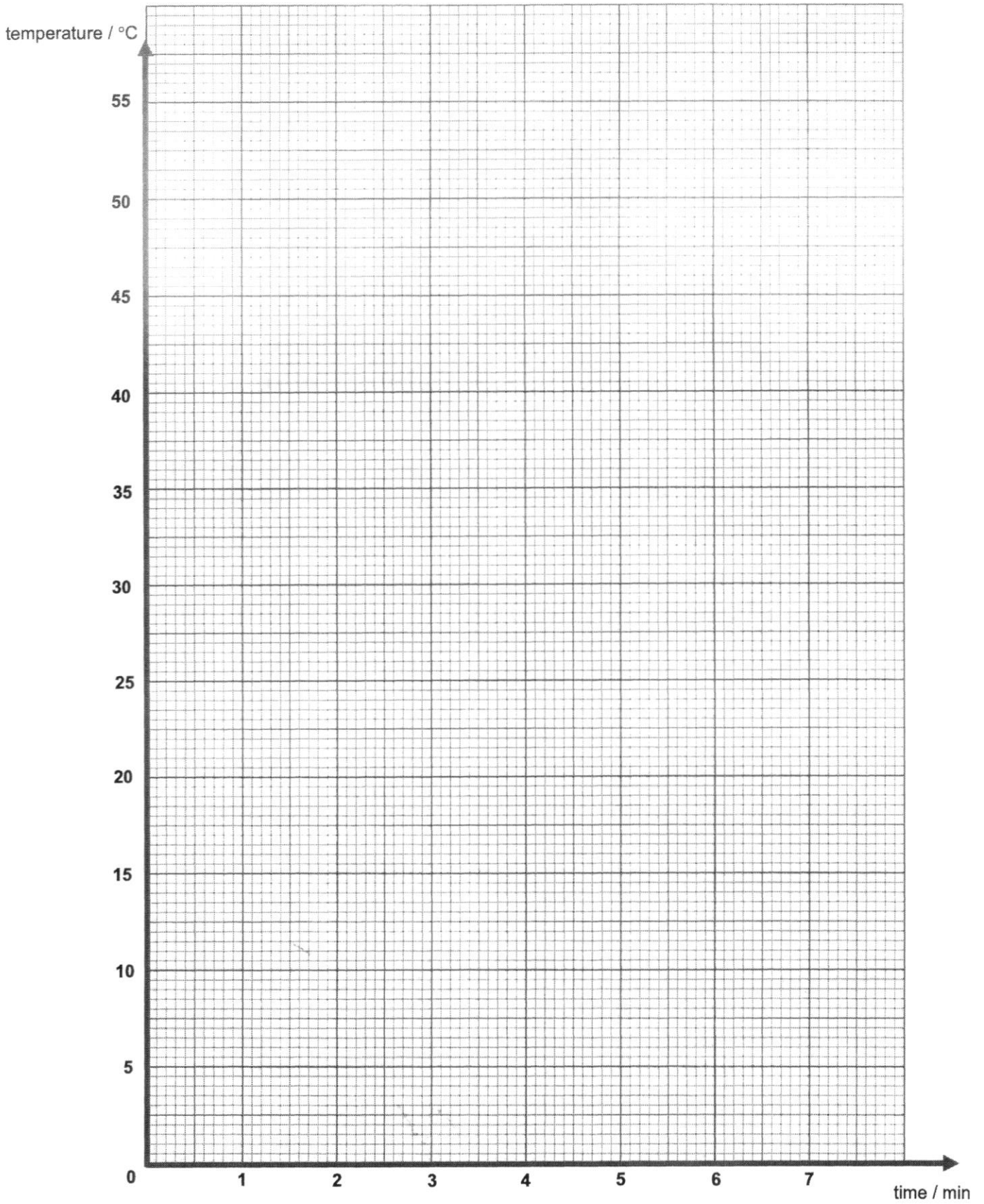

- 10 Fig. 10.1 shows a photo of statues called Caryatids that were built on the Acropolis in Athens more than 2500 years ago. The statues are made of a type of rock called marble. Marble is composed mainly of calcium carbonate. In 1980, the original statues were transferred inside the museum of the Acropolis and were replaced by replicas because the original statues were being eaten away by acid rain.

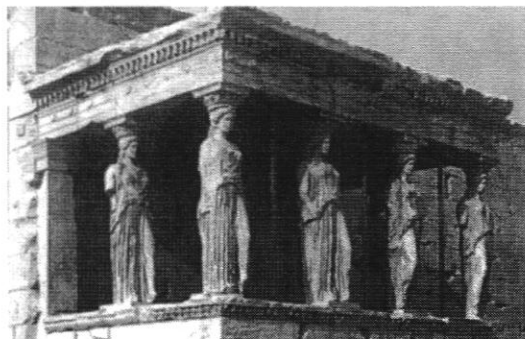

Fig. 10.1

Normal rain is slightly acidic because it has absorbed some carbon dioxide ( $\text{CO}_2$ ) from the air. Acid rain is more acidic than normal rain because it has absorbed gases such as sulfur dioxide ( $\text{SO}_2$ ). Sulfur dioxide forms sulfuric acid in rainwater.

When acid rain falls on the Caryatids, the sulfuric acid in acid rain will react with the calcium carbonate in marble to form a salt called calcium sulfate and two other products.

- (a) Write a word equation to represent the reaction of sulfuric acid and calcium carbonate.

..... [2]

- (b) Describe a test to show that acid rain is more acidic than normal rain.

.....

..... [2]

- (c) Sulfuric acid can also react with alkali such as calcium hydroxide.

- (i) State one similarity and one difference between the reaction of sulfuric acid and calcium carbonate and the reaction of sulfuric acid and calcium hydroxide.

.....

.....

..... [2]

Fig. 10.2 shows an experimental set-up where sulfuric acid and calcium hydroxide were added in the tank, and wax was smeared at the end of four rods.

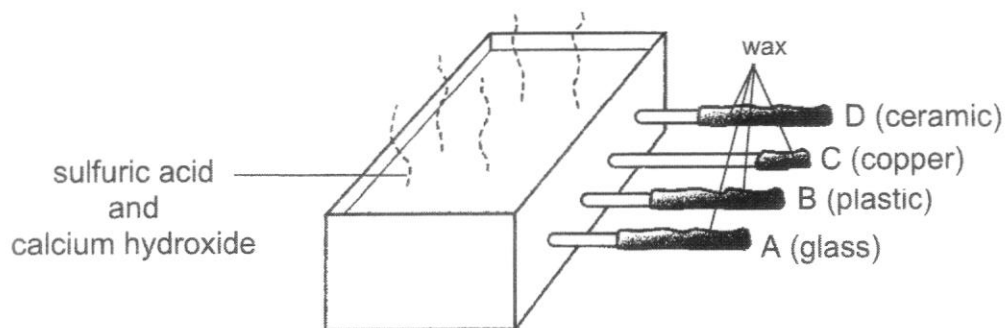

Fig. 10.2

The reaction of sulfuric acid and calcium hydroxide produces heat. After some time, the amount of wax left is shown in Fig. 10.2.

(ii) Which method of heat transfer caused the wax to melt?

..... [1]

(iii) In terms of particles, describe how heat is transferred to the wax and explain the amount of wax left on rod C.

.....  
 .....  
 .....  
 .....  
 ..... [3]

END OF PAPER

Admiralty Sec School  
Marking Scheme  
2E Lower Secondary Science  
Mid-Year Examination 2022

SECTION A [20 marks]

1	2	3	4	5	6	7	8	9	10
D	B	C	D	A	B	A	C	A	D
<b>11</b>	<b>12</b>	<b>13</b>	<b>14</b>	<b>15</b>	<b>16</b>	17	<b>18</b>	<b>19</b>	<b>20</b>
D	B	C	A	C	D	A	A	C	D

SECTION B [40 marks]

\*overall minus one mark if missing formula

^ overall minus one mark if missing / wrong unit

Qn.	Description	mark	Remarks
1(a)	Frictional force	[1]	
	Gravitational force	[1]	
(b)	contact force	[1]	
	frictional force		
(c)	work done = Force x distance = 200N x 50cm = 200 N x 0.5 m = 100 j	[1]	
		[1]	
		[1]	

Qn.	Description	Mark	Remarks
2(a)	Electrical energy	[1]	
	to kinetic energy	[1]	
(b)	Kinetic energy	[1]	
	to gravitational potential energy	[1]	

Qn.	Description	Mark	Remarks
3(a)	Substance A has <u>expanded</u> .	[1]	A: increase in volume / size
(b)	Heating	[1]	A: heat R: fire / flame
(c)(i)	Convection	[1]	A: convection current
(c)(ii)	Process X takes place at the <u>centre-bottom of the glass container</u> .	[1]	A: bottom
	When the liquid in the glass container is heated at the bottom, it <u>expanded</u> and became <u>less dense</u> , causing it to <u>rise</u> .	[1]	
	The colder water at the top will <u>sink down</u> as it is <u>denser compared to the heated liquid</u> at the bottom.	[1]	
	This sets up the convection current.		

Qn.	Description	Mark	Remarks
4	When there is a fire, the <u>temperature of the surrounding will increase</u> .	[1]	A: bimetallic strip is heated
	Hence, <u>heat energy will flow from the surrounding to the metallic strip</u> , causing it to <u>expand</u> .	[1]	
	The <u>brass layer expands more than the iron layer</u> , causing the bimetallic strip to <u>bend inwards</u> .	[1]	
	This causes the bimetallic strip to <u>touch the contact point</u> , <u>closing the circuit</u> and activating the fire alarm.	[1]	

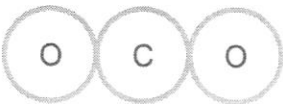
Qn.	Description	Mark	Remarks
5(a)	Heat	[1]	
(b)		[1]	A: all other arrangement of atoms, as long as they are combined together (only 1 product B formed)
(c)	$32 + 128 = 88 + M$ $M = 160 - 88 = \underline{72 \text{ g}}$ By the conservation of mass, the <u>total mass of the reactants must be equal to the total mass of the products.</u>	[1] [1] [1]	
(d)	<b>Benefit</b> - releases energy from fuel to allow us to cook, power transportation, generate electricity etc  <b>Harmful effect</b> - releases air pollutants, which can lead to breathing difficulties - releases greenhouse gases, which can lead to global warming	[1] [1]	
(e)(i)	Thermal decomposition is a process in which a substance is <u>broken down into two or more simpler substances</u> upon <u>heating</u> .	[1]	
(e)(ii)	Both requires <u>heat</u> .	[1]	
(e)(iii)	substance P $\rightarrow$ substance Q + substance R + substance S	[1]	

Qn.	Description	Mark	Remarks
6(a)	Plants <u>Only plants can make their own food, so X needs to be plant to provide food for the rest of the organisms in the food chain.</u>	[1] [1]	
(b)	Lost as <u>heat energy</u> during <u>respiration and excretion</u> .	[1]	
(c)	$24500 \times 0.1 \times 0.1$ $= 245 \text{ J}$	[1] [1]	

Qn.	Description	Mark	Remarks
7(a)	It has <u>increased</u> over the years	[1]	
(b)	More transport/cars on the roads and More industrialisation/factories leading to more use of fuels/electricity	[1] [1]	
(c)	Carbon dioxide <u>traps heat in atmosphere</u> , causing <u>global warming</u> , leading to undesirable effects to the ecosystem	[1] [1]	

## SECTION C [20 marks]

Qn.	Description	Mark	Remarks
8(a)(i)	Fossil fuels	[1]	
(a)(ii)	It cannot be replaced and will be eventually be used up.	[1]	
(a)(iii)	Solar energy Singapore is usually bright and sunny throughout the day.	[1] [1]	Reject: Sun energy
(a)(iv)	<b>Renewable sources of energy</b> Advantage: clean, generally does not cause pollution Disadvantage: expensive to set up and maintain the infrastructure  <b>Non-renewable sources of energy</b> Advantage: much cheaper and affordable. Disadvantage: causes air pollution when burnt.	[1] [1]  [1]  [1]	
(b)	<u>Nail A has a smaller area of contact with the wall so the pressure exerted will be greater</u> , when the same force is applied to it.	[1] [1]	

Qn.	Description	Mark	Remarks
9(a)	All 7 points plotted correctly with a cross (×).	[1]	
	Best-fit line through the 7 points.	[1]	
(b)	The temperature will continue to <u>decrease till it reaches room temperature.</u>	[1]	R: decrease
	The <u>temperature of water</u> in the container is <u>higher than that of the surrounding.</u> Hence, <u>heat will flow from the water to the surrounding</u> until there is no difference in temperature.	[1]	
(c)(i)	A steeper line that reaches a temperature lower than 39.5 °C at t = 7 min.	[1]	R: temperature is less than 20 °C at t = 7 min
(c)(ii)	Black is a <u>better emitter of heat</u> than white.	[1]	
	Hence, <u>heat lost from the black container is faster</u> and hence, temperature drop is steeper.	[1]	
(d)	calcium oxide + water → calcium hydroxide	[1]	
(e)	Chemical change.		R: did not specify calcium hydroxide
	A new substance, calcium hydroxide, is formed.	[1]	
	Heat is given out when calcium oxide is mixed with water.	[1]	

Qn.	Description	Mark	Remarks
10(a)	sulfuric acid + calcium carbonate → calcium sulfate + water + carbon dioxide	[2]	1 mark for word equation  1 mark for water and carbon dioxide  R: salt instead of calcium sulfate
(b)	Add <u>universal indicator</u> to both acid rain and normal rain.  The universal indicator will turn <u>red in acid rain and orange in normal rain</u> , showing that acid rain is more acidic than normal rain.	[1]  [1]	A: a more acidic colour in acid rain than normal rain
(c)(i)	Both reactions will produce <u>salt and/or water</u> .  The reaction of sulfuric acid and calcium carbonate produces <u>carbon dioxide</u> , but the reaction of sulfuric acid and calcium hydroxide does not produce carbon dioxide.	[1]  [1]	
(c)(ii)	Conduction	[1]	
(c)(iii)	When the rod is heated by the mixture in the tank, the <u>particles in the rod nearest to the tank gained kinetic energy and move faster</u> .  These particles will <u>collide with the neighbouring particles to pass down the thermal energy</u> . The process continues until the thermal energy is passed till the end of the rod.  The amount of wax left on C is the least because <u>copper is the best conductor of heat</u> due to the <u>presence of mobile electrons</u> that helps to transfer thermal energy along the rod.	[1]  [1]  [1]	