

*Visit*

**FREETESTPAPER.com**

*for more papers*



Website: [freetestpaper.com](http://www.freetestpaper.com)



[Facebook.com/freetestpaper](https://www.facebook.com/freetestpaper)



[Twitter.com/freetestpaper](https://www.twitter.com/freetestpaper)

Register No.      Class

Name: \_\_\_\_\_

--	--

**'Perseverance Yields Success'****Ping Yi Secondary School**

Mid-Year Examination 2022

Secondary 2 Express

**SCIENCE****Duration: 2 hours****INSTRUCTIONS TO CANDIDATES****Do not open this booklet until you are told to do so.**

Write your name, class and register number in the spaces at the top of this page.  
Write in dark blue or black pen.

You may use a soft pencil for any diagrams, graphs or rough working.  
Do not use staples, paper clips, glue or correction fluid.

**Section A:** There are 30 questions in this paper. Answer **all** the questions.  
Choose the most suitable answer and shade your answer in the Optical Answer Sheet (OAS) provided.

**Section B:** Answer **all** questions in the spaces or on the lines provided.

**Section C:** Answer **all** questions in the spaces or on the lines provided.

In calculations, you should show all the steps in your working, giving your answer at each stage.

The number of marks is given in brackets [ ] at the end of each question or part question.

A copy of the Periodic Table is printed on **page 27**.

FOR EXAMINER'S USE	
<b>Section A</b>	30
<b>Section B</b>	40
<b>Section C</b>	30
<b>Total</b>	100

Expected Grade	<input type="checkbox"/> A1	<input type="checkbox"/> A2	<input type="checkbox"/> B3	<input type="checkbox"/> B4	<input type="checkbox"/> C5
<b>Teacher's Comment</b>					
<b>Student's Comment</b>					
<b>Parent's Comment and Signature</b>					

This document consists of 27 printed pages including this cover page and insert.

**[Turn Over**

This examination paper is the property of Ping Yi Secondary School. It must not be duplicated in part or whole.



6 In which situation is work not done?

- A bouncing a basketball                      B throwing a ball in the air  
C holding a bag tightly                      D pushing a trolley

7 Ideas of expansion and contraction affect the design and construction of \_\_\_\_\_.

- I bridges  
II railway line  
III steam pipes

- A II and III only                      B I and II only  
C I and III only                      D I, II and III

8 A slice of meat is cooked on a metal plate in an electric grill.

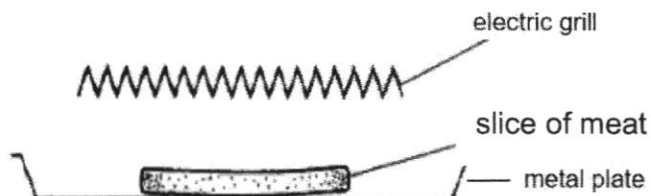

How does heat reach the meat?

- A by conduction only  
B by radiation only  
C by convection only  
D by conduction and radiation only

9 Kim noticed some cracks on the concrete floor on the pavement. What is the likely cause of the cracks?



- A constant exposure to sunlight only  
B constant heavy rain  
C constant daily expansion and contraction of concrete on the pavement  
D constant normal walking on the pavement

[Turn Over

- 10** A steel rod and a wooden rod were left in an air-conditioned room which was set at 10 °C for 2 hours. Norman entered the room and took one rod in each hand. He immediately dropped one of the rods which felt very cold. Which rod did he drop and why do you think he dropped the rod?

	rod	reason
<b>A</b>	steel	radiates coldness to his hand
<b>B</b>	steel	conducts heat away from his hand
<b>C</b>	wooden	absorbs heat from his hand
<b>D</b>	wooden	radiates coldness from his hand

- 11** A piece of ice wrapped in a metal wire gauze is placed into a test tube filled with some water. The test tube is heated near the top using a Bunsen burner. After several minutes, the top part of the water is observed to be boiling while the piece of ice can still be seen at the bottom.

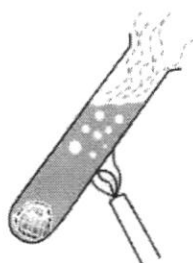

Which of the following is the correct conclusion for the test?

- A** Water is denser, hence will absorb heat faster than ice.  
**B** Wire gauze traps heat and water surrounding it will not boil.  
**C** Ice is in solid state and conducts heat away quickly.  
**D** Water is a poor conductor of heat.
- 12** Radiation differs from conduction and convection. Which of the following is true about this difference?
- A** Radiation takes place only at very high temperatures.  
**B** Radiation takes place only when objects are placed very close together.  
**C** Radiation does not require a medium to transfer energy.  
**D** Radiation can only take place on black and dull surfaces.

[Turn Over

- 13 Shawn sets up an electrolysis experiment on water as shown in the diagram below.

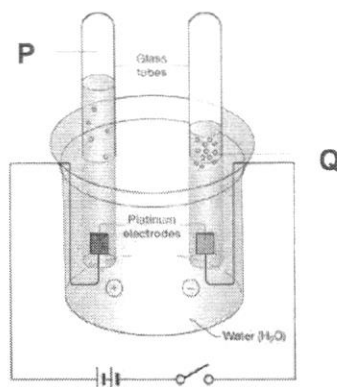

Which of the following statements about the experiment is true?

- A More bubbles are produced in test tube **P** than in test tube **Q**.  
 B Light is needed for the success of this experiment.  
 C This is an example of a combination reaction.  
 D This is an example of a decomposition process.
- 14 Which of the following processes are examples of oxidation reaction?

- I combustion  
 II decomposition  
 III photosynthesis  
 IV rusting

- A I and IV  
 B II and III  
 C I, III and IV  
 D III and IV

- 15 A piece of magnesium ribbon is added to a test tube containing a colourless liquid **X**. A salt and gas are produced. A simple test is carried out to identify the gas.

Which of the following is liquid **X** and what test is carried out to identify the gas?

	liquid <b>X</b>	test carried out to identify the gas
A	sodium hydroxide	bubble the gas into limewater
B	hydrochloric acid	bubble the gas into limewater
C	salt solution	test the gas with a lighted splint
D	hydrochloric acid	test the gas with a lighted splint

[Turn Over

- 16 Which of the following is an example of a chemical change?
- A dissolving sodium nitrate in water  
 B heating a mixture of iron and sulfur  
 C heating iodine crystals  
 D heating water in a test tube
- 17 A doctor prescribes antacid tablets to her patient seeking treatment of gastric pain. Gastric pain occurs when there is too much acid in the stomach. Which substance is most likely found in the antacid tablets?
- A hydrochloric acid  
 B magnesium hydroxide  
 C sulfuric acid  
 D sodium chloride

- 18 June carried out a simple experiment using litmus paper and Universal indicators on four colourless liquids at home and recorded the following results. Which of the following is true?

Liquid	Litmus paper	Universal indicator
P	remains red	turns red
Q	turns red	turns red
R	turns blue	turns blue
S	remains blue	remains green

Which two liquids, when mixed, will give a neutral liquid?

- A P and Q  
 B P and R  
 C R and S  
 D Q and S
- 19 Tapeworms are shaped like a tape measure. They cannot live freely on their own but can survive inside the gut of another organism. Drinking contaminated water or eating contaminated food are ways in which tapeworms get into the host's body. What is this type of relationship known as?
- A commensalism  
 B decomposition  
 C mutualism  
 D parasitism
- 20 A group of the same species of organisms living in the same habitat is known as a
- A biome.  
 B community.  
 C ecosystem.  
 D population.

[Turn Over





29 Which of the following is **not** an effect of an electric current?

- A an iron nail rusting
- B a tungsten wire heated up
- C a compass needle deflecting near a coil of wire
- D iron is extracted from iron ore

30 Identical resistors  $R_1$ , and  $R_2$  are connected as shown in the diagram below.

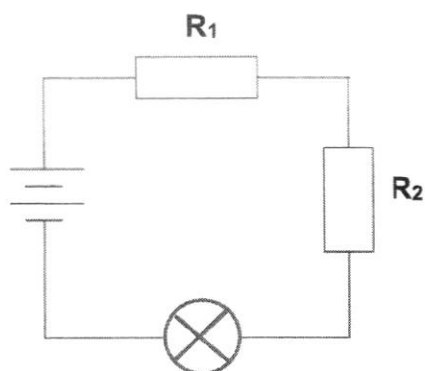

What observation is true when one of the resistors is removed from the circuit?

- A The bulb will not light up.
- B The bulb appears brighter.
- C The bulb appears dimmer.
- D The bulb will blow.

[Turn Over

**Section B (40 marks)**

Answer **all** questions in the spaces or on the lines provided.

- B1** Fig. 1.1 shows a beam balance, which can be used to measure the mass of an unknown object. The distance between the weighing pan and pivot is adjustable. The beam balance is balanced by a 50 g mass placed at  $d$  m from the pivot.

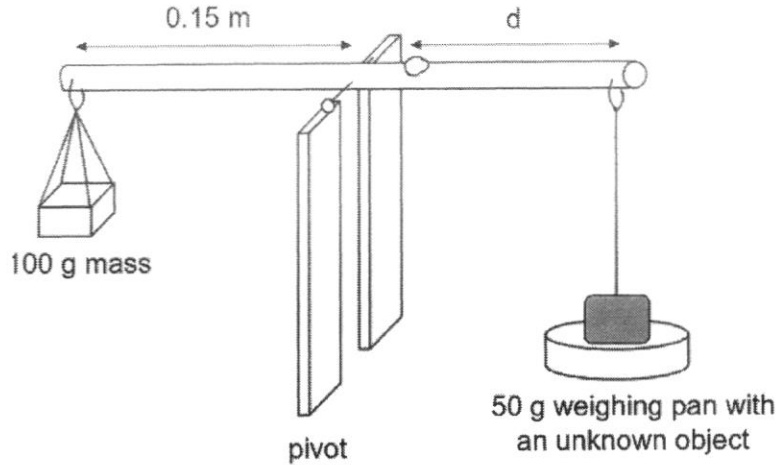

**Fig. 1.1**

- (a) Calculate the weight of the 100 g mass.  
(Take gravitational field strength = 10 N/kg). Show your working in the space below.

weight = ..... N [2]

- (b) Another two 50 g mass are added to the weighing pan.
- (i) Predict whether the beam balance will tilt in the clockwise or anticlockwise direction.  
..... [1]
- (ii) Suggest one possible way to balance the beam balance.  
You are not allowed to add or remove any weights from the beam balance.  
.....  
..... [1]

**[Turn Over**

- B2 (a)** Fig. 2.1 shows some chocolate wrapped in silver foil.

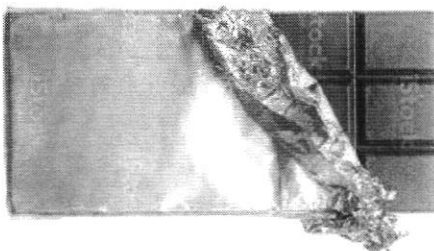
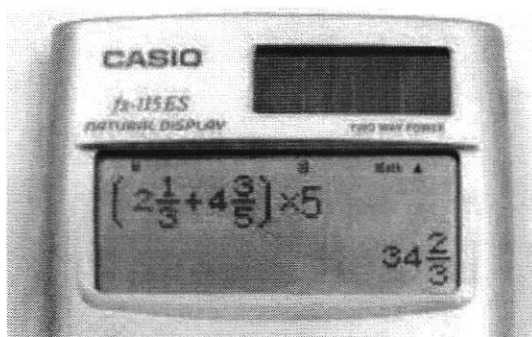

**Fig. 2.1**

Briefly explain why the chocolate wrapped in silver foil does not melt so easily.

..... [1]

- (b)** Fig. 2.2 shows a part of the solar calculator.



**Fig. 2.2**

- (i)** Explain why the solar panel is black in colour.

..... [1]

- (ii)** Trace the main energy change that take place when you use the calculator for 2 minutes. [2]



**[Turn Over**



- (b) Rhinoceros, goats, horses and cows are herbivores. Tigers not only prey on calves but also adult horses, cows and goats. Based on the description of the interaction between the living organisms, construct a food web in the box below. [2]

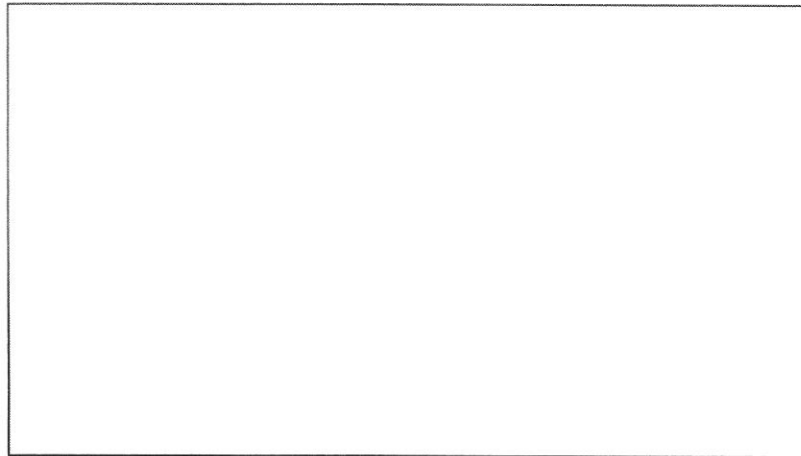

- B5 (a) Fill in the blanks with examples of contact and non-contact forces from the given list. [2]

*frictional force      weight      electrostatic force      magnetic force*

contact force	non-contact force

- (b) Bricks of the same volume and weight are stacked on top of each other in four different ways, as shown in Fig. 5.1.

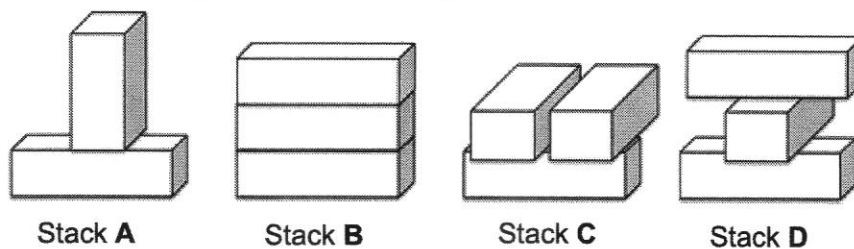

**Fig. 5.1**

Which stack exerts the least pressure on the table surface? Explain your answer.

.....

.....

..... [2]

[Turn Over

**B6** Table 6.1 shows the distance covered, time taken and speed of 3 different animals.

**Table 6.1**

animal	distance	time	speed / km/h
cheetah	64 km	$\frac{1}{2}$ h	
peregrine falcon	97.25 m	$\frac{1}{4}$ h	
humming bird	98 km	60 min	

**(a)** Given that speed is the ratio of distance over time, calculate the speed of each animal. Show your working neatly in the space provided and record the speed in **Table 6.1**. [3]

**(b)** Hence, which animal has the greatest speed?

..... [1]

**B7** Siti carried her 6 kg school bag and climbed up a flight of steps of total distance 1.2 m to her classroom.



**(a)** Is there any work done by her on her school bag? Suggest a reason to support your answer.

.....  
 .....  
 ..... [2]

**[Turn Over**

- (b) She used a measuring instrument to measure the height of each step. State an appropriate instrument she would use to take this measurement.

..... [1]

- (c) Calculate the work done. Show your working.  
Assume that acceleration due to gravity on earth is  $10 \text{ m/s}^2$ .

work done = ..... Nm [2]

**B8** Fig. 8.1 shows how Kelly uses power supply at home.

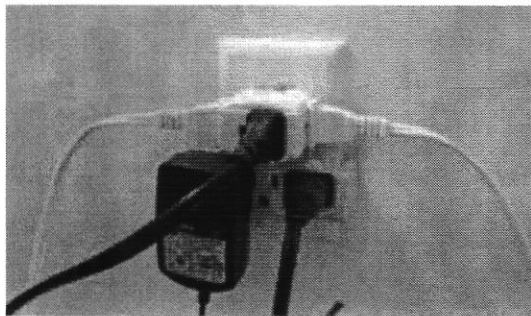

**Fig. 8.1**

- (a) Identify what is not safe in this connection. Explain why it is so.

.....  
 .....  
 ..... [2]

- (b) Suggest to Kelly an action she can take to use electricity safely.

..... [1]

**[Turn Over**

**B9** Indicate, on the pH scale, with arrow and label to show the appropriate positions of the substances listed below. [4]

*acid in car battery*      *toothpaste*      *vinegar*      *sodium hydroxide*

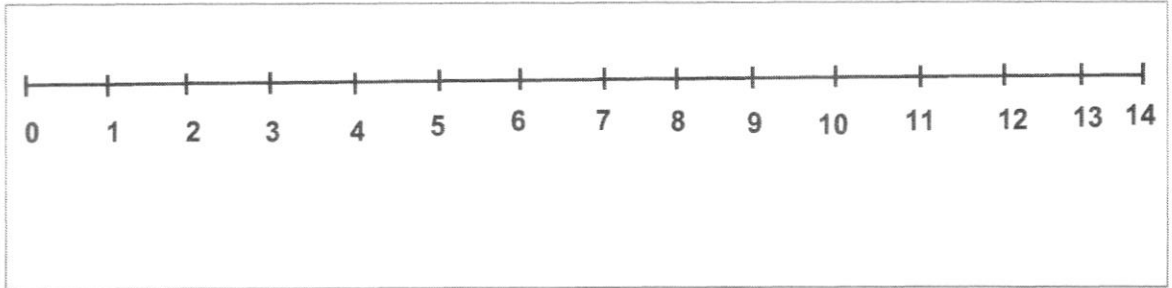

**B10** The article was posted by The Washington Post about a fire that took place in Australia in 2020. Ecologists have been trying to track the koala which they fear will go into extinction if nothing is done to save the remaining species.

**The Washington Post**

Asia

**Koalas are getting harder to find. Scientists in Australia are on a quest to uncover a hidden population.**

By Michael E. Miller  
January 12, 2022 at 4:03 a.m. EST

Two years ago, when bush fires supercharged by climate change killed or displaced an estimated 3 billion animals, thousands of koalas were among the dead. Between the blazes, drought, disease and deforestation, almost a third of the country’s koalas have disappeared since 2018, according to one conservation group. The federal government is weighing whether to label half the country’s koalas as endangered.

(a) Explain what do you understand by the phrase, “half the country’s koalas as endangered”.

.....

..... [1]

[Turn Over

(b) What is one action mentioned in the article that man had done or are still doing that has caused climate change?

.....

..... [1]

(c) Suggest one way in which man can reduce the rate of climate change.

.....

..... [1]

(d) In what way is climate change dangerous to man apart from endangering some species of animals?

.....

..... [1]

**[Turn Over**

**Section C (30 marks)**

Answer *all* the questions in the spaces or on the lines provided.

- C1 (a) Sheep has fur covering on its body while the man in the picture wears a woolen jacket to keep warm.



- (i) Explain how do the fur and woolen jacket keep the sheep and the man warm respectively.

.....  
 ..... [2]

- (ii) Mandy took some wool and conducted an experiment to explain how wool can keep man warm.

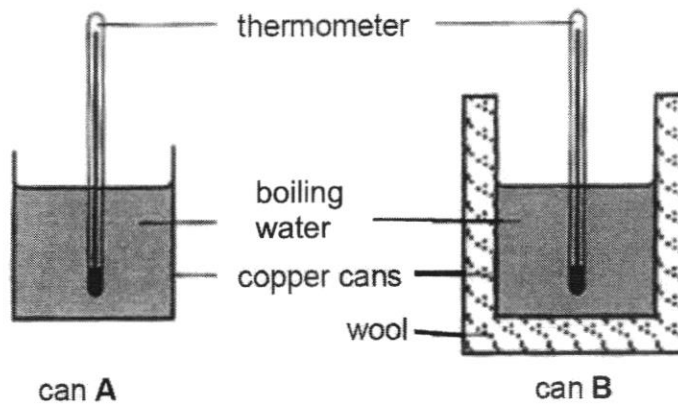

She filled two identical copper cans, **A** and **B**, with 300 ml of boiling water as shown in the diagram.

The temperature of the water in each can is taken every minute. The temperature of can **B** is plotted against time as shown in the graph on page 18.

[Turn Over

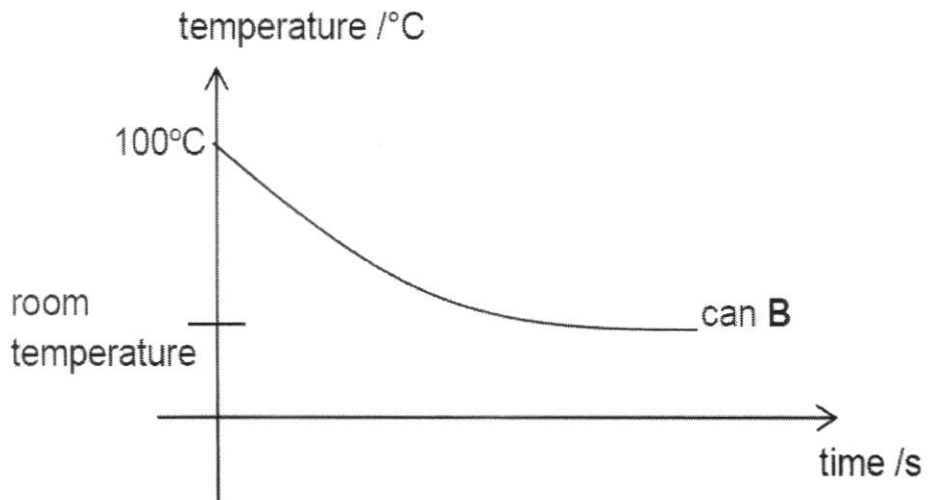

On the same graph, sketch a possible curve for the temperature taken for can A. Label this curve as "can A". [1]

Explain the graph that you have drawn for can A.

.....

.....

..... [1]

(b) Another method of ensuring that man is kept warm especially during the winter season is to have a heater installed in the house.

(i) In the box below, draw a rectangle to indicate where you would install the heater in the living room and write the word "heater" in your rectangle. [1]

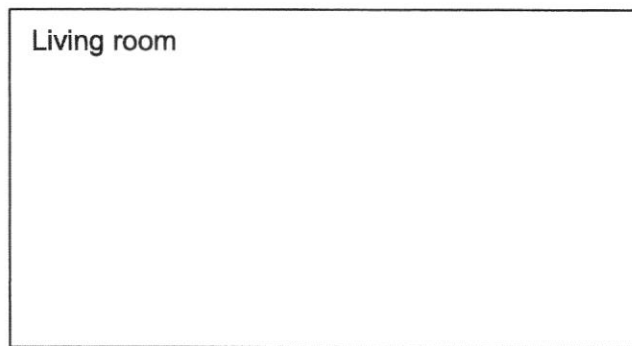

(ii) Explain why you have chosen to install the heater in that location shown in (b)(i).

.....

..... [1]

**[Turn Over**

- (c) Fig. 1.1 shows a LARQ bottle that can remove lead, chlorine and VOCs from tap water. It is also able to keep water hot up to 12 hours or keep water cold up to 24 hours.



Photo: LARQ



double wall

Longitudinal section of LARQ bottle

Fig. 1.1

Fig. 1.2 shows the longitudinal section of a traditional vacuum flask.

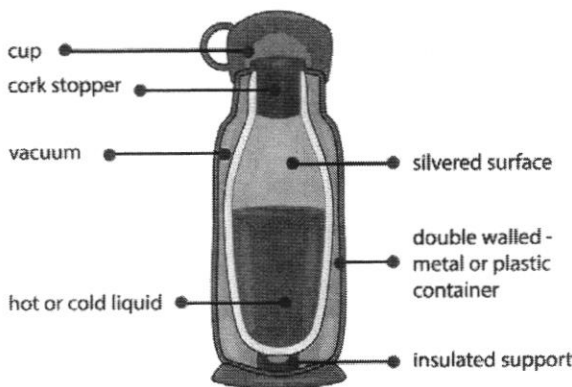

Longitudinal section of traditional vacuum flask

Fig. 1.2

- (i) State a similarity between the interior of a traditional vacuum flask and a LARQ flask.

..... [1]

- (ii) Both flasks have a cover to prevent heat loss. State the type of heat loss that is prevented by the cover.

..... [1]

- (iii) The double wall in the vacuum flask is usually silver in colour. Explain why silver is used.

..... [2]

[Turn Over

**C2** Wei Sheng uses the apparatus shown in Fig. 2.1 to investigate some reactions.

In each reaction, a solid reacts with dilute hydrochloric acid and the volume of gas produced is measured using a gas syringe.

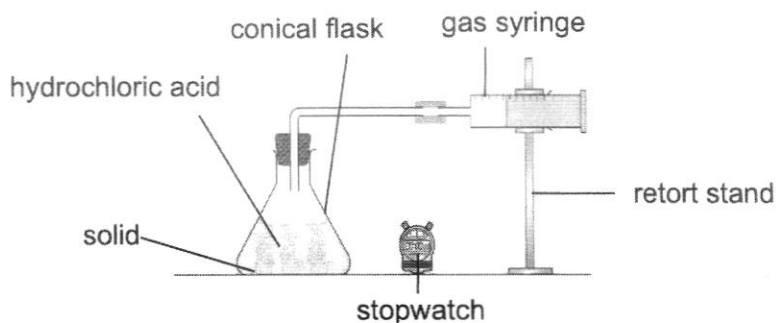

**Fig. 2.1**

Table 2.1 lists four experiments in which four different solids are reacted with hydrochloric acid.

**Table 2.1**

experiment	solid reacted	observation
1	egg shells	<ul style="list-style-type: none"> <li>• bubbles are seen</li> <li>• heat is given out</li> </ul>
2	zinc	
3	copper	
4	sodium hydroxide	<ul style="list-style-type: none"> <li>• no bubbles are seen</li> <li>• heat is given out</li> </ul>

Egg shells used in experiment 1 are found to contain calcium carbonate.

(a) Write the word equation for the reaction between calcium carbonate and hydrochloric acid.

..... [1]

(b) Describe a test that can be used to test for the gas formed in experiment 1 and the expected observation. [2]

test: .....

expected observation: .....

**[Turn Over**

- (c) State the type of change that experiment 1 has undergone.  
 ..... [1]
- (d) Briefly explain your reason for part (c).  
 ..... [1]
- (e) Complete Table 2.1 by filling in the observation for experiment 3. [1]
- (f) State one *physical* property of sodium hydroxide.  
 ..... [1]
- (g) Wei Sheng commented that no bubbles were seen in experiment 4.
- (i) Explain why.  
 ..... [1]
- (ii) Describe and explain what happens to the pH when hydrochloric acid was slowly added to the sodium hydroxide solution in experiment 4.  
 .....  
 ..... [2]

[Turn Over

- C3 (a)** Fig. 3.1 shows the circuit in an electric kettle. The kettle requires a current of 9.0 A to work.

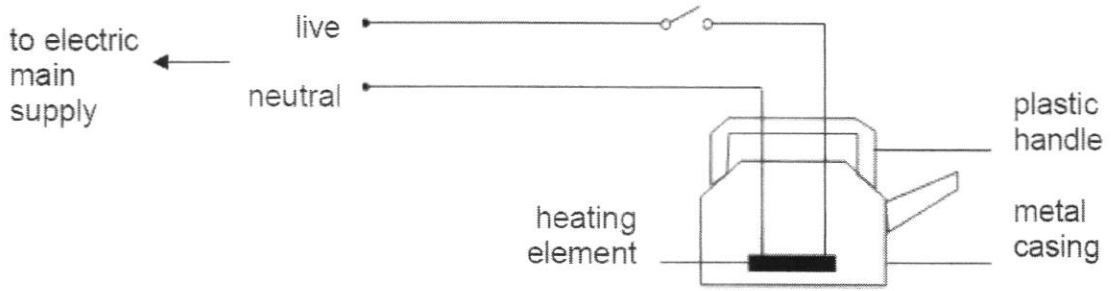

**Fig. 3.1**

- (i) The live wire must not touch the metal casing. Explain why this connection can be hazardous to users should the live wire touches the metal casing.

..... [1]

- (ii) Indicate with an 'X' on Fig. 3.1 to show the correct position to place a fuse. [1]

- (iii) Supplier P carries fuses with the following ratings as shown in Table 3.1. (NB: amp rating is the same as fuse rating)

**Table 3.1**

KT CODE	FUSE COLOUR	AMP RATING
KTBFM3	Pink	3 Amps
KTBFM5	Orange	5 Amps
KTBFM7.5	Brown	7.5 Amps
KTBFM10	Red	10 Amps
KTBFM15	Blue	15 Amps
KTBFM20	Yellow	20 Amps
KTBFM25	Clear	25 Amps
KTBFM30	Green	30 Amps

Suggest which fuse rating should the supplier fit into this electric kettle and explain your choice.

..... [2]

**[Turn Over**

- (b) Janice bought some electrical appliances and she compiled the power rating of these electrical appliances in Table 3.2.

**Table 3.2**

Electrical appliance	Power rating
air-conditioner	3.5 kW
electrical kettle	1 200 W
washing machine	0.5 kW
ceiling fan	50 W
electric iron	1 kW

- (i) State which electrical appliance(s) will consume the highest and lowest amount of energy per hour.  
 the highest amount of energy : ..... [1]  
 the lowest amount of energy : ..... [1]
- (ii) Janice read The Sunday Times, March 6 2022 about the open electricity market (OEM) rates offered to home users.

A2 | THE BIG STORY THE SUNDAY TIMES SUNDAY, MARCH 6, 2022



The Energy Market Authority warned that consumers will likely see higher prices when they renew or sign up for new plans. This is because volatility in the wholesale electricity market has shot up with the ongoing global energy crisis, which has been worsened by supply disruptions due to the Russia-Ukraine war. (PHOTO: KIM CHYF 10/20)

## Open electricity market retail rates up, closing gap with SP tariff

Energy Electricity Contracting Regulator Nicholas (Chris) Corbridge said the market is now more competitive and that the average electricity bill for a typical household in Singapore has fallen by 10% since the market opened in December. EMA has urged consumers to shop around for the best deal when they sign up for a new plan.

She is interested to take up a 12-month contract with one of the electricity contracting retailers. The table shows the cost of using electricity from each retailer.

[Turn Over

12-month contract			
Retailer	Plan	Electricity rate (per kWh)	Monthly bill*
Senoko Energy	LiteSave12	6% off the regulated tariff	\$89.90
Geneco	Get It Fixed 12	26.8 ¢	\$94.16
Keppel Electric	Fixed 12	26.88 ¢	\$94.44
Senoko Energy	LitePower12 (3% green energy)	27 ¢	\$94.86
Semcorp Power	12M Fixed Price Home	27.1 ¢	\$95.21
Tuas Power Supply	PowerFix 12	27.11 ¢	\$95.25
PacificLight Energy	Sunny Side-Up 12m (green plan)	27.11 ¢	\$95.25
PacificLight Energy	Savvy Saver 12	27.11 ¢	\$95.25

NOTE:\*Estimated for 4-room HDB flat

SOURCE: compare.openelectricitymarket.sg

SUNDAY TIMES GRAPHICS

Janice installed three identical air-conditioner units in her house. The three air-conditioners are turned on from 6.00 pm to 12.00 midnight. Calculate the total amount of electrical energy consumed by the three air-conditioner units in kilowatt-hour, kWh, per day. Show your working in the space provided below. [2]

[Turn Over

- (iii) She decided to sign a 12-month contract with Geneco. Calculate the electrical bill Janice has to pay for using the three air-conditioner units for 30 days. Show your working in the space provided below. [1]

For the same usage, Janice used to pay \$378 based on the old rate of \$0.20 per kWh. What is the difference in amount she has to pay when she changed to the retailer, Geneco? Show your working in the space provided below. [1]

End of Paper

Ping Yi Secondary School  
2022 Mid-Year Exam  
Secondary 2E Marking Scheme

## Section A (30%)

1	C	11	D	21	D
2	A	12	C	22	B
3	B	13	D	23	C
4	D	14	A	24	D
5	C	15	D	25	B
6	C	16	B	26	D
7	D	17	B	27	C
8	B & D	18	B	28	C
9	C	19	D	29	A
10	B	20	D	30	B

Qn	Explanation
11	Many wrote this answer as A. Students did not know that the ice did not melt despite being wrapped in a metal wire gauze. The presence of water prevented the conduction of heat to the ice since water is a poor conductor of heat.
15	Many did not know that magnesium is a metal. Hence since salt and gas is produced, this must be an acid-metal reaction. An acid+metal reaction would liberate hydrogen gas and a salt.
16	A chemical change occurs when new substances are formed, heat is given out. Hence dissolving sodium nitrate in water result in a physical change since no new substances are formed etc.
17	Students fail to see the link that with too much acid in the stomach, there is a need for an alkali to neutralize the acid. An alkali would contain hydroxide.
25	Many made careless mistake and forgot the rate of flow of electric charges is current.
28	Many could not do the question and gave their answer as B. When switch 2 is closed the entire circuit cannot be functioning on 2A since it is a parallel circuit.

## Section B (40%)

Qn	Answer	Remarks
B1a	100 g = 0.1 kg Weight = 0.1 x 10 N = 1 N	2
bi	clockwise	1
bii	decrease the distance of weighing pan from the pivot / move the weighing pan nearer to the pivot / move pivot closer to weighing pan	1
	Generally well answered. Not accepted: adjust distance between weighing pan and pivot.	
	Total	4 marks
B2a	Silver is a poor absorber of heat.	1
bi	Black is a better absorber of heat energy.	1
bii	Light energy → electrical energy [1] → light energy + heat energy [1]	2
	(a) Accepted: Silver is a good reflector of heat / good conductor of heat.	

[Turn Over]

This examination paper is the property of Ping Yi Secondary School. It must not be duplicated in part or whole.

	(b) Generally well answered. (c) Not accepted: Light energy → chemical energy Must have: <u>light energy</u> + sound energy / heat energy				
	Total				4 marks
<b>B3a</b>	<b>beneficial</b>		<b>harmful</b>		2
	cellular respiration , brushing teeth with toothpaste, decay of dead organisms		burning of forests		
<b>b</b>	(i) decay of dead organisms / cellular respiration				1
	(ii) it destroys the habitat of living organisms and may cause them to become extinct / produces carbon dioxide gas which cause global warming or increasing the temperature of the environment				1
	Students gave their own answers such as combustion, heating, thermal decomposition rather than infer from the paragraph.				
	Total				4 marks
<b>B4a</b>	Mutualism as the oxpecker helps to remove ticks and parasites from the rhino's body while the food remains from the rhino is feed by oxpecker.				2
<b>b</b>					2
	Generally well answered except for a handful who did not indicate with arrows or did not start with primary producer.				
	Total				4 marks
<b>B5a</b>	Contact force		Non-contact force		2
	Frictional force		Magnetic force		
			Weight (pull of gravity)		
			Electrostatic force		
<b>b</b>	Stack A as it has only 2 bricks while the other stacks have 3 bricks each. Hence, force is least while the surface area is the same resulting in least pressure exerted.				2
	(a) Generally well answered. (b) Not well answered. Most students chose B as the answer with reason like least or largest surface area.				
	Total				4 marks
<b>B6a</b>	animal	distance	time	speed / km/h	3
	cheetah	64 km	½ h	128	
	peregrine falcon	97.25 m	¼ h	389-0.389	
	humming bird	98 km	60 min	98	
<b>b</b>	Peregrine falcon-cheetah				1

[Turn Over

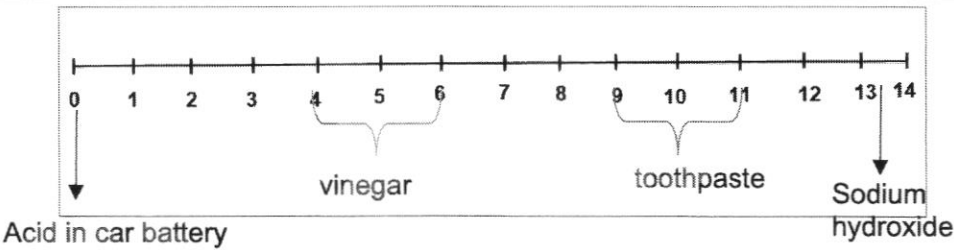
	(a) Error arise mainly from conversion of units. (b) Wrong answer given due to error in (a). Students given marks under error carried forward.	
	Total	4 marks
<b>B7a</b>	Yes, she uses a force and the bag moves in the direction of the force.	2
<b>b</b>	Ruler / measuring tape	1
<b>c</b>	Work done = force x distance travelled = $6 \times 10 \text{ N} \times 1.2 \text{ m}$ = 72 Nm	2
	(a) and (b) are generally well answered. (c) Students either forget to change force to N or multiplied 10 the distance.	
	Total	5 marks
<b>B8a</b>	Multiple plugs at one socket. May result in electrical fire due to too much current drawn from the socket.	1 1
<b>b</b>	Check the power of each electrical appliance that she is plugging into the socket to ensure that not too much current is drawn from there.	1
	(a) Overuse of the term short circuit.	
	Total	3 marks
<b>B9</b>		4
	Not well learnt.	
	Total	4 marks
<b>B10a</b>	Endangered means a drastic decrease in koalas that may cause them to become extinct.	1
<b>b</b>	deforestation	1
<b>c</b>	Plant more trees	1
<b>d</b>	Can cause sea level to rise / more floods	1
	Generally well answered. Not accepted: "endangered means getting extinct." Or "using the word endangered in the answer or decreased a lot." (d) Not accepted: climate change without further explanation and weather change instantly.	
	Total	4 marks

## Section C (30%)

Qn	Answer	Remarks
<b>C1ai</b>	Wool and fur traps pockets of air.	1
	Air being a poor conductor of heat will prevent heat loss from the body by conduction.	1

<b>Markers Report</b>	Most students were able to identify that there were some pockets of air that helped to keep warm. However many missed the marking point of air being a good insulator/poor conductor of heat.	
aii	<p>The heat from copper can A is lost to the surrounding faster as it does not have the insulation like in can B.</p> <p>the curve flatten as it has reached the room temp</p>	1  1
<b>Markers Report</b>	Most students were able to draw the curve for Can A, whereby the drop in temperature is faster due to no wool being present to keep the container warmer. Many could not get the 2 <sup>nd</sup> mark on the curve tapering earlier at room temperature.	
bi		1
bii	Cold air being denser sinks and will be heated up by the heater at the bottom of the room. The less dense hotter air rise and a convection current is set up to maintain a constant warm temperature inside the house.	1
<b>Markers Report</b>	Most students were able to answer this question and could grasp the concept of hot air being lighter rises and cold air being heavier sinks. This then creates a convection current to maintain a constant warm temperature. Some students used the termed convection cycle instead of convection current.	
ci	Both have double wall	1
<b>Markers Report</b>	Question was well done.	
cii	Conduction and convection cannot take place.	1
<b>Markers Report</b>	This question was poorly attempted. Many students forgot that both conduction and convection is taking place.	
ciii	Silver is a poor radiator of heat/good reflector of heat/poor absorber of heat/poor emitter of heat and hence retains the heat longer.	1 1
<b>Markers Report</b>	This question was poorly attempted. Many students did not understand how the shiny surface would help to retain the heat longer.	

[Turn Over

		Total	10
<b>C2a</b>	calcium carbonate + hydrochloric acid $\longrightarrow$ calcium chloride + carbon dioxide + water		1
<b>Markers Report</b>	<i>Many students could not identify the salt name and just gave a general term salt. Weaker students fail to recognize that carbon dioxide gas is given off and wrote hydrogen gas instead.</i>		
<b>b</b>	Test: Bubble the gas into limewater. Expected observation: A white precipitate is formed		1 1
<b>Markers Report</b>	<i>Question was poorly attempted. There was poor scientific phrasing and most students wrote limewater test.</i>		
<b>c</b>	Chemical change		1
<b>d</b>	Heat is given out/New products are formed/ Reaction is irreversible.		1
<b>Markers Report</b>	<i>This question was well done.</i>		
<b>e</b>	No bubbles are seen. No heat is given out.		1
<b>Markers Report</b>	<i>Many students forgot the Copper is an unreactive metal. Hence it would not want to react with an acid.</i>		
<b>f</b>	Soapy feel / turns moist red litmus blue / turns Universal indicator blue		1
<b>Markers Report</b>	<i>Question was poorly attempted. Many wrote physical properties of sodium hydroxide as alkaline/colourless/clear. All these were NOT accepted.</i>		
<b>g(i)</b>	There is no gas given off/Neutralisation has taken place		1
<b>(ii)</b>	When hydrochloric acid is added to sodium hydroxide solution, the pH decreases. pH decreases till it reach pH 7, neutralise.		1 1
<b>Markers Report</b>	<i>Better students were able to identify that this was a neutralization process and that pH of 7 would be reached. However they missed the part on pH decreasing since acid is being added to sodium hydroxide.</i>		
		Total	10
<b>C3a(i)</b>	when the live wire touches the metal casing, the metal casing becomes 'live' and can cause electrocution/electric shock.		1
<b>(ii)</b>	X should be next to live wire		1
	<p style="text-align: center;">Fig. 3.1</p>		
<b>Markers Report</b>	<i>Students were able to identify that placing the fuse was supposed to be placed near the live wire as a safety device. Weaker ones forget the intent of the fuse and placed it at the neutral wire.</i>		

(iii)	10A or KTBFM10 which will allow sufficient current to flow through the kettle and if current exceeds 10 A, the current will be cut off.	1 1
<b>Markers Report</b>	<i>Students didn't manage to get the 2nd mark on why a 10A fuse was used. Many just wrote that it was the nearest largest current and having too large a current is not safe. Many fail to mention that having a 10A fuse for a 9A current would allow the 9A current to flow and break off once more than 10A is passed through as a safety device.</i>	
b(i)	Highest amount of energy – air conditioner Lowest amount of energy - ceiling fan	1 1
<b>Markers Report</b>	<i>This question was well done. Students who got this wrong forgot the conversion of 1kW=1000W</i>	
(ii)	3 air-conditioners turned on for 6 h daily = 3 x 6 = 18 h  Energy used = 3.5 x 18 kWh = 63 kWh	1  1
<b>Markers Report</b>	<i>Some students didn't read the question properly and calculated the cost instead of the electrical energy consumed. Some weaker students had difficulty calculating the number of hours that the air-conditioners was left on.</i>	
(iii)	Cost of using 3 air-conditioners for 6 h daily for 30 days at \$0.268/unit = \$ (63 x 30 x 0.268) = \$ 506.52  Difference she has to pay = \$506.52 - \$378.00 = \$128.52  Allow for error carried forward if the cost is wrong.	1   1
<b>Markers Report</b>	<i>Students failed to recognize that if they were to pay per kWh using Geneco, it would cost \$0.268 per kWh, rather than a monthly bill.</i>	
	Total	10

[Turn Over