

Visit

FREETESTPAPER.com

for more papers



Website: [freetestpaper.com](http://www.freetestpaper.com)



[Facebook.com/freetestpaper](https://www.facebook.com/freetestpaper)



[Twitter.com/freetestpaper](https://www.twitter.com/freetestpaper)



2NA

KRANJI SECONDARY SCHOOL

END-OF-YEAR EXAMINATION 2018

MATHEMATICS 4045

PAPER 1

Level : Secondary Two

Date : 03 October 2018

Stream : Normal (Academic)

Duration : 1 hour 30 min

Name : _____ ()

Marks :

Class : Secondary 2 _____

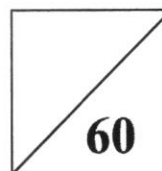

READ THESE INSTRUCTIONS FIRST:

Write your class, index number and name on all the work you hand in.

Write in dark blue or black pen.

You may use an HB pencil for any diagrams or graphs.

Do not use staples, paper clips, glue or correction fluid.

Answer **all** questions.

The number of marks is given in brackets [] at the end of each question or part question.

If working is needed for any question it must be shown with the answer.

Omission of essential working will result in loss of marks.

The total of the marks for this paper is 80.

The use of an approved scientific calculator is expected, where appropriate.

If the degree of accuracy is not specified in the question, and if the answer is not exact, give the answer to three significant figures. Give your answers in degrees to one decimal place.

For π , use either your calculator value or 3.142.

Set by : Ms Pow Li Ting

This question paper consists of 13 printed pages including the cover page.

[Turn over]

Mathematical Formulae

Compound Interest

$$\text{Total amount} = P \left(1 + \frac{r}{100} \right)^n$$

Mensuration

$$\text{Curved surface area of a cone} = \pi r l$$

$$\text{Surface area of a sphere} = 4\pi r^2$$

$$\text{Volume of a cone} = \frac{1}{3} \pi r^2 h$$

$$\text{Volume of a sphere} = \frac{4}{3} \pi r^3$$

$$\text{Area of triangle } ABC = \frac{1}{2} ab \sin C$$

$$\text{Arc length} = r\theta, \text{ where } \theta \text{ is in radians}$$

$$\text{Sector area} = \frac{1}{2} r^2 \theta, \text{ where } \theta \text{ is in radians}$$

Trigonometry

$$\frac{a}{\sin A} = \frac{b}{\sin B} = \frac{c}{\sin C}$$

$$a^2 = b^2 + c^2 - 2bc \cos A$$

Statistics

$$\text{Mean} = \frac{\sum fx}{\sum f}$$

$$\text{Standard deviation} = \sqrt{\frac{\sum fx^2}{\sum f} - \left(\frac{\sum fx}{\sum f} \right)^2}$$

Answer **all** the questions.

- 1 (a) Find the fraction which is halfway between $\frac{1}{2}$ and $\frac{1}{4}$.

Answer [1]

- (b) Arrange the numbers in ascending order.

$\frac{7}{9}$ $0.\dot{8}$ 0.82 $(0.9)^2$

Answer , , , [2]

- 2 A car travels for $1\frac{1}{2}$ hours at 50 km/h. It then travels for 2 hours at 65 km/h.
Find the average speed for the whole journey.

Answer km/h [3]

3 Factorise the following expressions completely.

(a) $3x - ax + 3y - ay$

Answer [2]

(b) $4m^2 - 4m - 15$

Answer [2]

4 Petrol cost x cents per litre. David buys some petrol and it costs him y dollars.
Find an expression, in terms of x and y , for the number of litres that David buys.

Answer litres [2]

- 5 Mr Ang bought a box of 100 mini chocolate bars and a bag of 140 candies. He intends to pack them into identical snack packs for his students.

Find

- (i) the greatest number of snack packs he could obtain,

Answer [1]

- (ii) the number of mini chocolate bars in each snack pack.

Answer [1]

- 6 (a) Solve the inequality $3x > x + 8$

Answer [2]

- (b) Hence write down the smallest integer value of x .

Answer $x =$ [1]

7 Which of these ratios are equivalent to the ratio $a : b$? Circle two. [2]

$$a^2 : b^2$$

$$3a : 3b$$

$$ak : bk$$

$$a+1 : b+1$$

8 (a) Express $x^2 + 6x + 7$ in the form $(x+a)^2 - b$.

Answer [1]

(b) Hence solve the equation $x^2 + 6x + 7 = 0$, giving your answers correct to two decimal places.

Answer $x =$ or [2]

- 9 Triangle ABC is an isosceles triangle. $BC = (2r - 4)$ cm and $AB = AC = r$ cm. $AF = (r - 3)$ cm is the perpendicular height of triangle ABC .

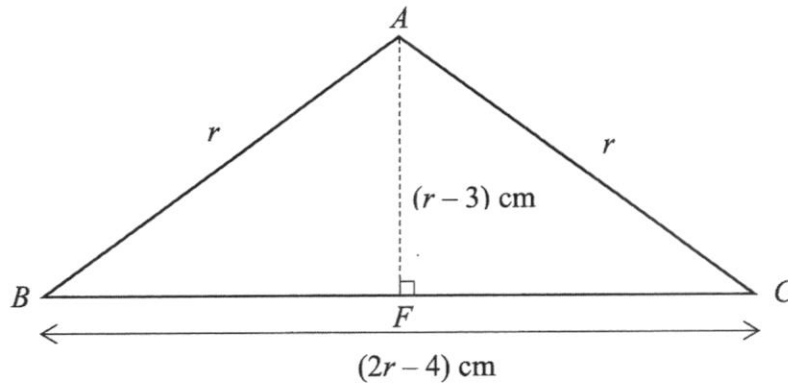

- (a) Write down an expression, in terms of r , for BF .

Answer $BF = \dots\dots\dots$ cm [1]

- (b) By using Pythagoras' Theorem, form an equation in r and show that it reduces to $r^2 - 10r + 13 = 0$ [2]

- (c) Solve the equation $r^2 - 10r + 13 = 0$.

Answer $\dots\dots\dots$ or $\dots\dots\dots$ [2]

- 10** Dree's parents deposit money into her bank account on her birthday every year. They deposited \$100 into her bank account on her first birthday. On her second birthday, \$150 was deposited, \$200 was deposited on her third birthday and so on. The deposit amount increases by \$50 each year.

(a) Complete the table below. [1]

Age (Years)	Deposit Amount
1	\$100
2	\$150
3	\$200
4	

(b) Write down an expression for the deposit amount when Dree turns n years old.

Answer \$ [1]

(c) If Dree's parents decide to stop depositing after Dree's deposit amount reaches \$1500, what will be Dree's age for the last deposit?

Answer years old [2]

- 11 In the diagram shown, QRS is a straight line.
 $PR = 13$ cm, $PQ = 5$ cm, $RQ = 12$ cm, $RS = 3$ cm.

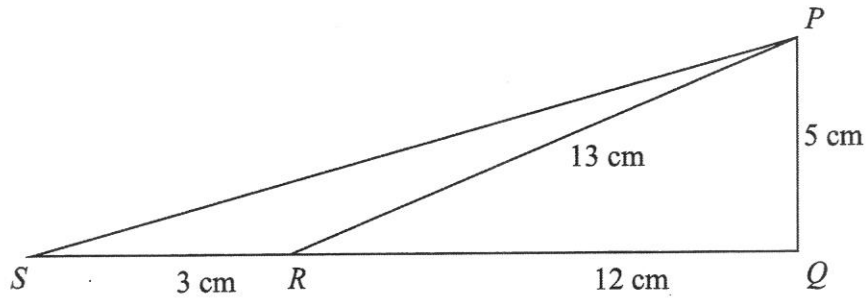

- (a) Show that triangle PQR is a right-angled triangle. [3]

- (b) Hence find the value of $\angle PRQ$.

Answer [2]

- (c) Without the use of calculator, write down the exact value of $\tan \angle PSQ$.

Answer [1]

- 12 The diagram below shows a triangle ABC with points $A(2, 5)$, $B(8, 5)$ and $C(12, 9)$.

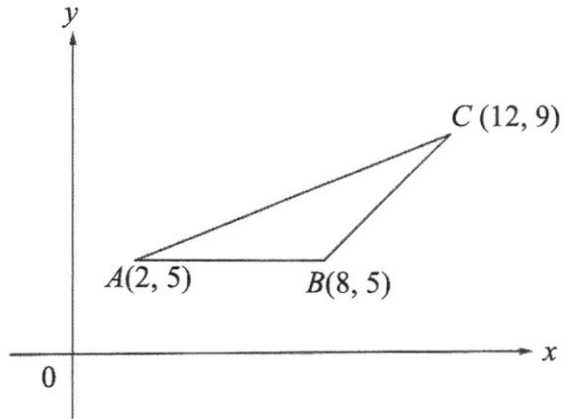

- (a) Find the length of AC

Answer units [2]

- (b) Find the equation of AC .

Answer [3]

- (c) Find the area of triangle ABC .

Answer units² [2]

13 Simplify $3x \div \frac{6x^4}{5}$.

Answer [2]

14 Solve the simultaneous equations

$$x + 2y = 5$$

$$2x + 3y = 9$$

Answer $x =$

$y =$ [3]

15 Find the value of k if

(i) $(p^3)^4 = p^k$

Answer $k = \dots\dots\dots$ [1]

(ii) $6^k = 1$

Answer $k = \dots\dots\dots$ [1]

(iii) $\frac{1}{25} = 5^k$

Answer $k = \dots\dots\dots$ [1]

16 (i) Find the size of each interior angle of a regular polygon with 18 sides.

Answer $\dots\dots\dots^\circ$ [2]

(ii) Hence, or otherwise, calculate the size of each exterior angle of a regular polygon with 18 sides.

Answer $\dots\dots\dots^\circ$ [1]

17 Assume the Earth is a perfect sphere with diameter 12742 km.

- (a) Calculate the volume of the Earth in km^3 .
Leave your answer in standard form, correct to 3 significant figures.

Answer km^3 [3]

- (b) The volume of the Moon is $2.1958 \times 10^{10} \text{ km}^3$. Calculate how many times greater in volume the Earth is compared to the Moon. Give your answer correct to the nearest integer.

Answer [2]

End of paper



2NA

KRANJI SECONDARY SCHOOL

END-OF-YEAR EXAMINATION 2018

MATHEMATICS 4045

PAPER 2

Level : Secondary Two

Date : 05 Oct 2018

Stream : Normal (Academic)

Duration : 1 hour 30 min

Name : _____ ()

Marks : 45

Class : Sec 2 _____

READ THESE INSTRUCTIONS FIRST:

Write your class, index number and name on all the work you hand in.

Write in dark blue or black pen.

You may use an HB pencil for any diagrams or graphs.

Do not use staples, paper clips, glue or correction fluid.

Section A

Answer **all** questions.

Section B

Answer **one** question.

The number of marks is given in brackets [] at the end of each question or part question.

If working is needed for any question it must be shown with the answer.

Omission of essential working will result in loss of marks.

The total of the marks for this paper is 45.

The use of an approved scientific calculator is expected, where appropriate.

If the degree of accuracy is not specified in the question, and if the answer is not exact, give the answer to three significant figures. Give your answers in degrees to one decimal place.

For π , use either your calculator value or 3.142.

At the end of the examination, fasten all your work securely together.

Set By: Ms Pow Li Ting

This question paper consists of 8 printed pages including the cover page.

[Turn over]

Mathematical Formulae

Compound Interest

$$\text{Total amount} = P \left(1 + \frac{r}{100} \right)^n$$

Mensuration

$$\text{Curved surface area of a cone} = \pi r l$$

$$\text{Surface area of a sphere} = 4\pi r^2$$

$$\text{Volume of a cone} = \frac{1}{3} \pi r^2 h$$

$$\text{Volume of a sphere} = \frac{4}{3} \pi r^3$$

$$\text{Area of triangle } ABC = \frac{1}{2} ab \sin C$$

$$\text{Arc length} = r\theta, \text{ where } \theta \text{ is in radians}$$

$$\text{Sector area} = \frac{1}{2} r^2 \theta, \text{ where } \theta \text{ is in radians}$$

Trigonometry

$$\frac{a}{\sin A} = \frac{b}{\sin B} = \frac{c}{\sin C}$$

$$a^2 = b^2 + c^2 - 2bc \cos A$$

Statistics

$$\text{Mean} = \frac{\sum fx}{\sum f}$$

$$\text{Standard deviation} = \sqrt{\frac{\sum fx^2}{\sum f} - \left(\frac{\sum fx}{\sum f} \right)^2}$$

Answer all questions.

1 Expand and simplify $(3x - 2y)(4x + y)$. [2]

2 a is directly proportional to b^2 .

Given that $a = 27$ when $b = 3$, find

(a) an expression for a in terms of b , [2]

(b) the value of a when $b = \frac{1}{11}$ [1]

3 A classroom in the shape of a rectangle is 8.6 m long and 7.5 m wide.

(a) Calculate the area of the classroom in square metres. [2]

A floorplan of the school is drawn to a scale of 1 : 200.

(b) Calculate the area on the floorplan which represents the classroom, giving your answer in square centimetres. [2]

4 Mr Ong wishes to borrow \$30 000 from a bank and he intends to repay the loan in 3 years.

(a) Bank A charges simple interest of 5.68% per annum. Find the interest Mr Ong has to pay if he borrows from Bank A. [2]

(b) Bank B charges compound interest of 5.4% per annum, compounded yearly.
Which bank should Mr Ong borrow from? Justify your answer. [3]

5 Jorja made a profit of 15% when she sold a camera at \$759.

Calculate the cost price of the camera. [2]

6 It is given that $\sqrt{\frac{b-a}{5}} = c$.

(i) If $a = 1$, $c = 2$, find the value of b . [1]

(ii) Express b in terms of a and c . [3]

7 Express $\frac{4}{1-2x} + \frac{3}{x}$ as a single fraction in its simplest form. [3]

8 Alysha walks to school every day. Her school is 1.7 km away from home. The distance-time graph below shows her journey on a particular day. On her way to school, Alysha stopped at a convenience store to buy breakfast.

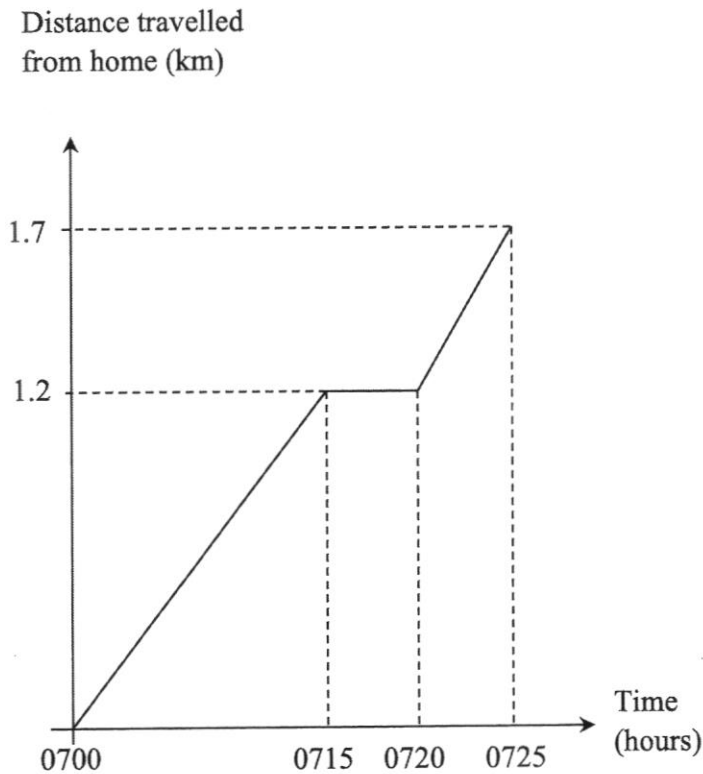

- (a) How far away is the convenience store from Alysha's home? [1]
- (b) How long did she spend at the convenience store? [1]
- (c) Did Alysha walk faster or slower after buying breakfast from the convenience store? [2]
Show your calculations clearly.

- 9 *Kuih Lapis* is a type of traditional steamed layer cake. It is commonly found in Singapore and is usually eaten as a snack. It is made by pouring rice flour mixture into a pan layer by layer during the steaming process.

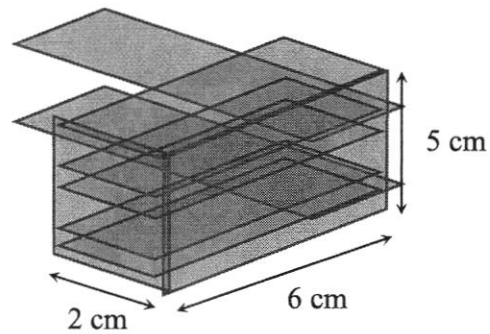
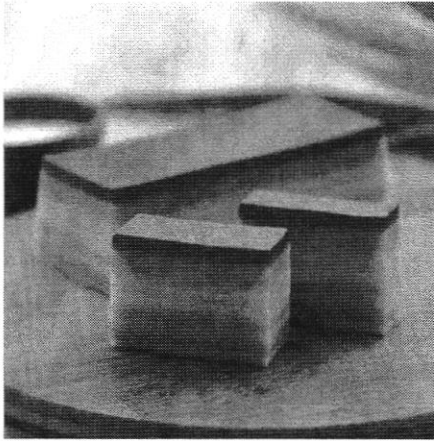

- (a) A piece of *kuih lapis* can be modelled using a cuboid measuring 2 cm in width, 6 cm in length and 5 cm in height. Calculate the volume of a piece of *kuih lapis* using dimensions given in the model.

[1]

The rice flour mixture is poured into a rectangular metal pan and steamed before individual pieces of *kuih lapis* are cut from it. The metal pan is shown in the diagram below.

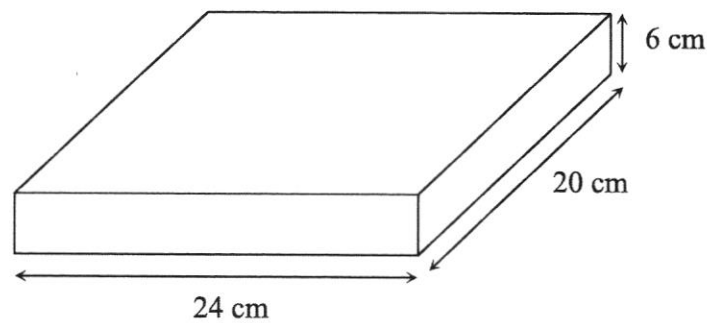

- (b) What is the maximum number of pieces of *kuih lapis* that can be made from steaming one pan of rice flour mixture?

[2]

- (c) Sally wishes to make a pan of rainbow-coloured *kuih lapis* that consists of 7 layers. She needs to buy a suitable ladle to scoop up the rice flour mixture.

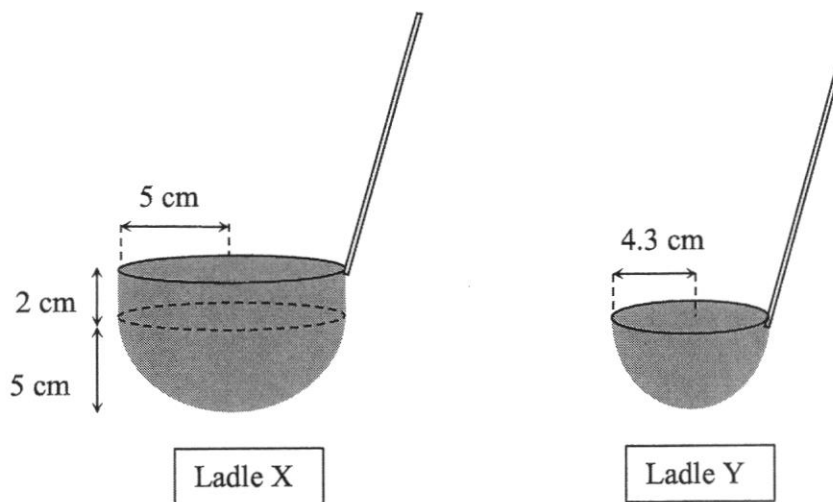

Ladle X is a composite figure which consist of a hemisphere and a cylinder. The cylinder has radius = 5 cm and height = 2 cm.

Ladle Y is a hemisphere with radius = 4.3 cm.

- (i) Calculate the volume of one layer of *kuih lapis* using the same rectangular metal pan shown in part (b). [1]
- (ii) Find the volume of rice flour mixture Ladle X can contain. [2]
- (iii) Find the volume of rice flour mixture Ladle Y can contain. [1]
- (iv) Which ladle should Sally buy in order to scoop out the rice flour mixture as accurately as possible for each layer? State your reason clearly. [1]

Section B (10 marks)

Answer one question from this section. Each question carries 10 marks.

10 Answer the whole of this question on the graph paper provided.

- (a) Copy and complete the table of values for $y = 2x - 3$.

x	-2	-1	0	1	2
y	-7			-1	

[1]

- (b) Write down the gradient and y -intercept of $y = 2x - 3$. [2]

- (c) Using a scale of 2 cm to 1 unit on both axes, draw the graph of $y = 2x - 3$ for the values of x from -2 to 2. [2]

- (d) From your graph, find the value of y when $x = 1.5$. [1]

- (e) The line $y = -6$ meets the graph at point A . State the coordinates of point A . [1]

- (f) On the same axes in (c), draw the graph of $y = -x$. [2]

- (g) Hence solve the simultaneous equations $y = 2x - 3$ and $y = -x$. [1]

- 11 (a) In the diagram below, $\angle KMN = 118^\circ$ and $\angle LKM = 79^\circ$.
 LKJ and LMN are straight lines. JI is parallel to LN .
 Calculate angle KJI . Show your reasoning clearly.

[3]

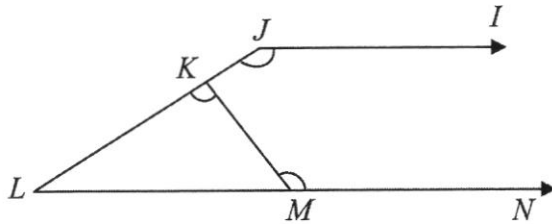

- (b) $ABCDEF$ is a regular hexagon. $\angle AFE = 120^\circ$, $\angle ABC = x^\circ$ and $\angle BCA = y^\circ$.

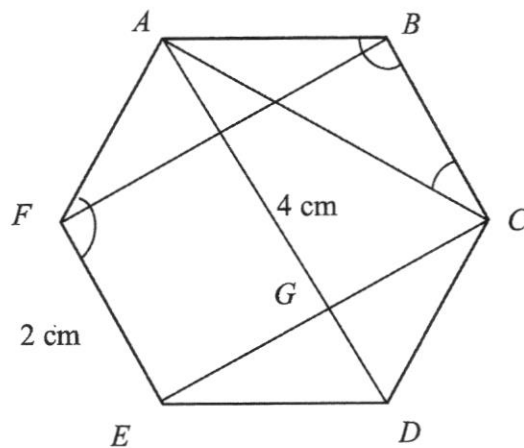

- (i) Find the values of x and y . [3]
- (ii) Given that $AD = 4$ cm, $FE = 2$ cm and the area of trapezium $AFED = 6.4$ cm²,
 find the perpendicular height, EG , of the trapezium. [2]
- (iii) Hence, find the area of rectangle $FBCE$. [2]

- End of Paper -

ANSWER KEY

Q	ANSWER
1a	$\frac{3}{8}$
1b	$\frac{7}{9}$, $(0.9)^2$, 0.82, $0.\dot{8}$
2	$58\frac{4}{7}$ km/h
3a	$(x+y)(3-a)$
3b	$(2m-5)(2m+3)$
4	$\frac{100y}{x}$ litres
5i	20
5ii	5
6a	$x > 4$
6b	5
7	$3a : 3b$, $ak : bk$
8a	$(x+3)^2 - 2$
8b	$x = -1.59$ or -4.41
9a	$r - 2$
9b	$r^2 - 10r + 13 = 0$ (shown)
9c	8.46 or 1.54
10a	\$250
10b	$\$(50n + 50)$
10c	29
11a	$PQ^2 + RQ^2 = RP^2$
11b	22.6°
11c	$\frac{1}{3}$
12a	10.8 units

12b	$y = \frac{2}{5}x + 4\frac{1}{5}$
12c	12 units ²
13	$\frac{5}{2x^3}$
14	$x = 3$ $y = 1$
15i	12
15ii	0
15iii	-2
16i	160°
16ii	20°
17a	1.08×10^{12}
17b	49

SEC 2 NA MATHEMATICS 4048 SA 2 2018
PAPER 2 MARK SCHEME

1	$(3x - 2y)(4x + y) = 12x^2 + 3xy - 8xy - 2y^2$ $= 12x^2 - 5xy - 2y^2$	
2	(a)	$a = kb^2$ $27 = k(3)^2$ $k = \frac{27}{9}$ $= 3$ $a = 3b^2$
	(b)	$a = 3b^2$ $= 3\left(\frac{1}{11}\right)^2$ $= \frac{3}{121}$
3	(a)	$\text{Area} = 8.6 \times 7.5$ $= 64.5 \text{ m}^2$
	(b)	$1 \text{ cm} \text{ --- } 200 \text{ cm}$ $1 \text{ cm} \text{ --- } 2 \text{ m}$ $1 \text{ cm}^2 \text{ --- } 4 \text{ m}^2$ $64.5 \text{ m}^2 \text{ --- } 16,125 \text{ cm}^2$
4	(a)	$\text{Interest} = \frac{(30000)(5.68)(3)}{100}$ $= \$5112$
	(b)	$A = 30000\left(1 + \frac{5.4}{100}\right)^3$ $= \$35127.164$ $I = \$35127.164 - \30000 $= \$5127.16$ <p>Mr Ong should borrow from Bank A as the interest is lower.</p>
5	<p>Let cost price of camera be x</p> $1.15x = 759$ $x = \$660$	

6	(i)	$\sqrt{\frac{b-1}{5}} = 2$ $\frac{b-1}{5} = 4$ $b-1 = 20$ $b = 21$
	(ii)	$\sqrt{\frac{b-a}{5}} = c$ $\frac{b-a}{5} = c^2$ $b-a = 5c^2$ $b = 5c^2 + a$
7	$\frac{4}{1-2x} + \frac{3}{x}$ $= \frac{4x}{x(1-2x)} + \frac{3(1-2x)}{x(1-2x)}$ $= \frac{4x+3(1-2x)}{x(1-2x)}$ $= \frac{4x+3-6x}{x(1-2x)}$ $= \frac{-2x+3}{x(1-2x)}$	
8	(a)	1.2 km
	(b)	5 min
	(c)	<p><u>Before</u></p> $\text{Speed} = \frac{1.2}{15}$ $= 0.08 \text{ km/min}$ <p><u>After</u></p> $\text{Speed} = \frac{1.7-1.2}{5}$ $= 0.1 \text{ km/min}$ <p>She walked faster after buying breakfast from the convenience store.</p>
9	(a)	$\text{Volume} = 2 \times 6 \times 5$ $= 60 \text{ cm}^3$
	(b)	$\text{number of pieces} = 4 \times 10$ $= 40$
	(c)	<p>(i) $\text{Volume of one layer} = 2400 \div 7$</p> $= 342\frac{6}{7} \text{ cm}^3$

	(ii)	$\text{Volume} = (\pi \times 5^2 \times 2) + \left(\frac{2}{3} \times \pi \times 5^3\right)$ $= 418.879 \text{ cm}^3$ $= 419 \text{ cm}^3$
	(iii)	$\text{Volume} = \left(\frac{2}{3} \times \pi \times 4.3^3\right)$ $= 166.519 \text{ cm}^3$ $= 167 \text{ cm}^3$
	(iv)	<p><u>Ladle X</u></p> $\text{Difference in Volume} = 418.879 - 342\frac{6}{7}$ $= 76.022 \text{ cm}^3$ <p><u>Ladle Y</u></p> $\text{Difference in Volume} = 2(166.519) - 342$ $= -9.819 \text{ cm}^3$ <p>Sally should buy Ladle Y as the difference in volume is the smallest.</p>
11	(a)	$\angle KML = 180^\circ - 118^\circ \text{ (angles sum of straight line)}$ $= 62^\circ$ $\angle MLK = 180^\circ - 62^\circ - 79^\circ \text{ (angles sum of triangle)}$ $= 39^\circ$ $\angle KJI = 180^\circ - 39^\circ \text{ (interior angles, LN//JI)}$ $= 141^\circ$
	(b) (i)	$x = 120^\circ$ $y = \frac{180^\circ - 120^\circ}{2}$ $= 30^\circ$
	(ii)	$6.4 = \frac{1}{2}(4+2)(h)$ $h = 2.13 \text{ cm}$
	(iii)	$\text{Area} = \left(2\frac{2}{15}\right)(2) \times 2$ $= 8.53 \text{ cm}^2$