

Visit

FREETESTPAPER.com

for more papers



Website: [freetestpaper.com](http://www.freetestpaper.com)



[Facebook.com/freetestpaper](https://www.facebook.com/freetestpaper)



ZHONGHUA SECONDARY SCHOOL
END-OF-YEAR EXAMINATION (2023)
SECONDARY 2 NORMAL (ACADEMIC)

CANDIDATE'S NAME

CLASS

INDEX NUMBER

--	--	--

MATHEMATICS SYLLABUS A

4045

29 September 2023

Candidates answer on the Question Paper.

2 hours

READ THESE INSTRUCTIONS FIRST

Write your name, class and index number on all the work you hand in.
Write in dark blue or black pen.
You may use an HB pencil for any diagrams or graphs.
Do not use paper clips, glue or correction fluid.

Answer **all** the questions.

The number of marks is given in brackets [] at the end of each question or part question.

If working is needed for any question it must be shown with the answer.

Omission of essential working will result in loss of marks.

The total of the marks for this paper is **70**.

The use of an approved scientific calculator is expected, where appropriate.

If the degree of accuracy is not specified in the question and if the answer is not exact, give the answer to three significant figures. Give answers in degrees to one decimal place.

For π , use either your calculator value or 3.142.

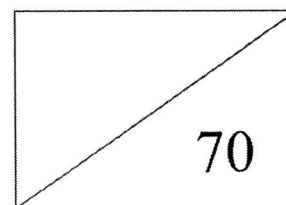

Answer **all** the questions.

1 Simplify $\frac{6y}{x} \times \frac{2}{3xy^2}$.

Give your answer as a single fraction in its simplest form.

Answer [2]

2 Express as a single fraction, in its simplest form, $\frac{2}{5}x - \frac{5(2-x)}{4}$.

Answer [2]

- 3 An **open** cone has a circular top of diameter 12 cm and a slant height of 7 cm. Calculate its curved surface area, giving your answer correct to 2 significant figures.

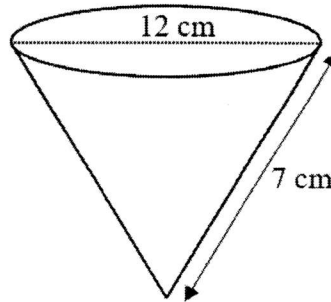

Answer cm² [2]

- 4 (a) Solve the inequality $-5n < 14$.

Answer [2]

- (b) Write down the smallest integer value for n .

Answer [1]

5 Expand and simplify each of the following.

(a) $(3 - 2w)(3 + 2w)$

Answer [1]

(b) $(4p + 1)^2$

Answer [2]

6 Solve $\frac{d-1}{2} - \frac{6-5d}{3} = 2$.

Answer $d =$ [3]

- 7 The diagram shows a shape with all the lengths given in centimetres.

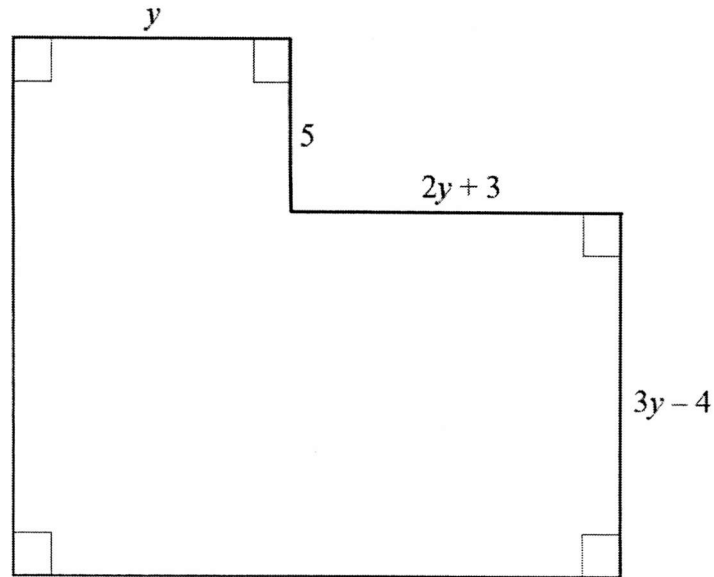

Find an expression, in terms of y , for the area of the shape.

Answer cm^2 [3]

- 8 Given that F is inversely proportional to the **cube** of R and $R = 2$ when $F = 4$, find

(a) an equation connecting F and R ,

Answer [2]

(b) the value of R when $F = 0.5$.

Answer $R =$ [1]

- 9 The diagram shows the sketch of a triangle ABC .

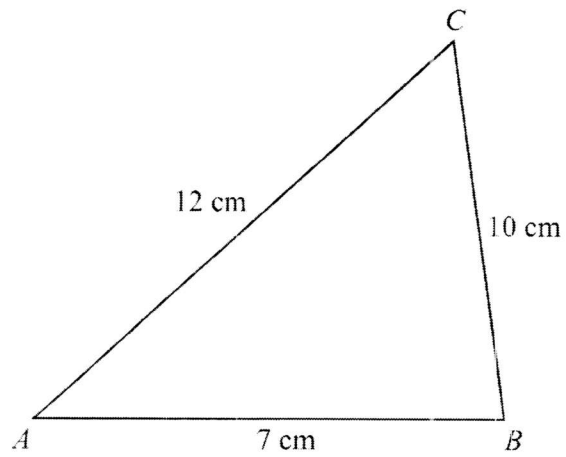

- (a) Construct an accurate full-sized drawing of triangle ABC .

Answer

[2]

- (b) Measure angle BAC .

Answer

[1]

10 The scale of a map is given as 1 : 20 000.

(a) Rewrite the scale in the form 1 cm to x km.

Answer 1 : [1]

(b) A paddy field on the map is 10 cm long.
Find the actual length of the field in kilometres.

Answer km [1]

(c) A swamp has an area of 5 km².
Find the area of the swamp on the map in square centimetres.

Answer cm² [2]

- 11 Trapezium $ABCD$ is similar to trapezium $PQRS$.
 $CD = 3$ cm, $QR = 3.7$ cm, $RS = 6$ cm and angle $BCD = 47^\circ$.

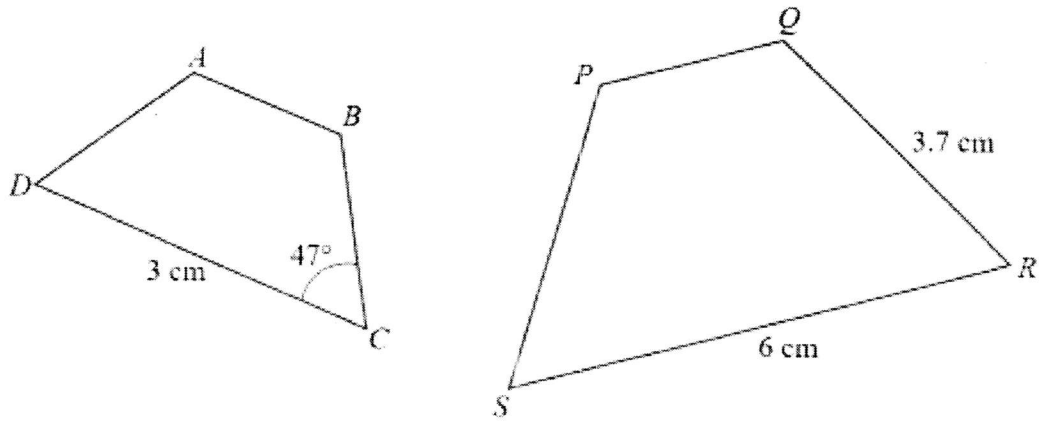

- (a) Find the length of BC .

Answer cm [2]

- (b) Find angle PQR .

Answer [2]

- 12 The masses (in grams) of 20 eggs are shown in the stem-and-leaf diagram below.

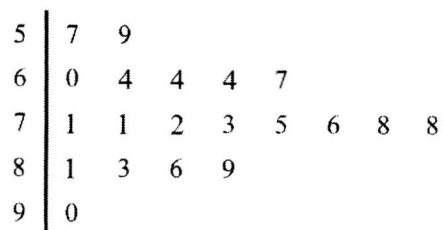

Key
1 | 2 means 12 grams

- (a) What is the difference in mass between the lightest and the heaviest egg?

Answer grams [1]

- (b) State the modal mass of the eggs.

Answer grams [1]

- (c) Find the median mass of the eggs.

Answer grams [2]

13 Factorise completely

(a) $35wy - 7w^2y,$

Answer [2]

(b) $3x^2 - 16x + 5,$

Answer [2]

(c) $2x^2 - 2.$

Answer [2]

- 14 (a) The exterior angle of a regular polygon is 45° .
How many sides does the polygon have?

Answer [2]

- (b) The diagram shows a polygon.
 DEF is a straight line.

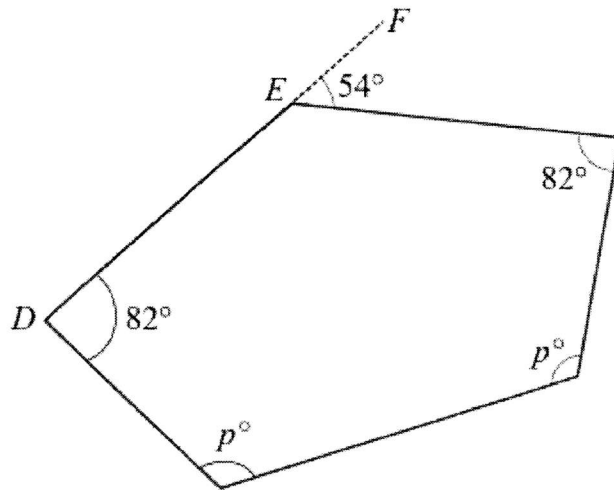

- (i) State the name of the polygon.

Answer [1]

- (ii) Find the value of p .

Answer [3]

- 15 The histogram shows the results of a survey conducted to find the number of phone calls made using handphones by a group of people in a certain month.

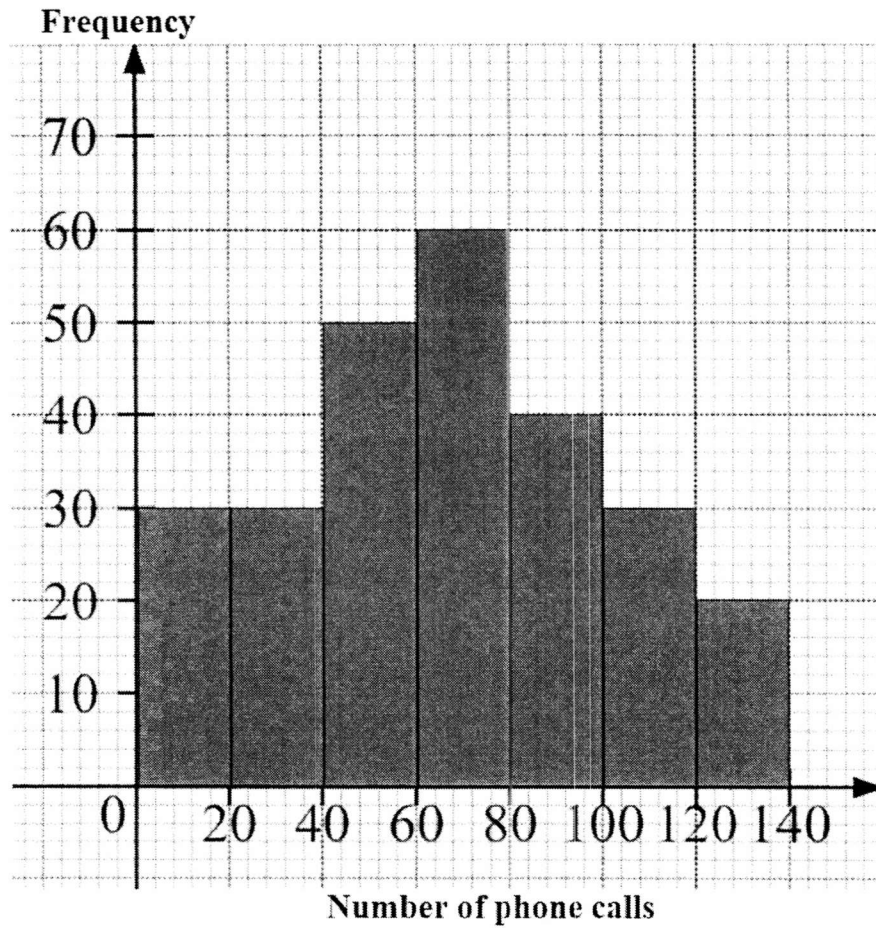

- (a) How many people were involved in the survey?

Answer people [1]

- (b) Find the percentage of people who made more than 100 phone calls in that month.

Answer % [2]

- (c) Calculate an estimate of the mean number of phone calls.

Answer phone calls [2]

- (d) Suggest why a dot diagram is not an appropriate statistical diagram to represent the data.

Answer
.....
..... [1]

- 16 Line P is shown on the grid.
The equation of line P is $3x + 2y = 6$.

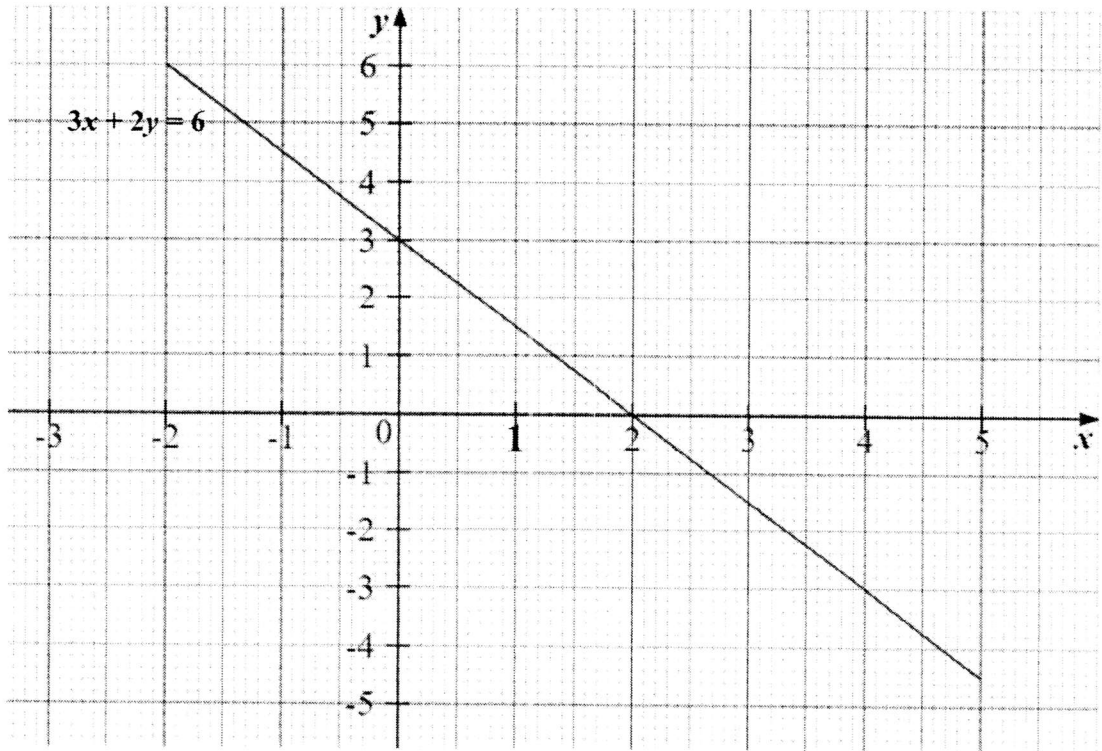

- (a) (i) Complete the table of values for $y = 1 - x$.

x	-2	0	3	5
y		1		-4

[1]

- (ii) Draw the line $y = 1 - x$.

[2]

- (b) Find the solution of these simultaneous equations.

$$\begin{aligned} 3x + 2y &= 6 \\ y &= 1 - x \end{aligned}$$

Answer $x =$

$y =$ [2]

- (c) (i) Find the gradient of line P .

Answer [1]

- (ii) Write down the y -intercept of the line $y = 1 - x$.

Answer [1]

- 17 Ryan is a local sculptor and his latest sculpture made from recycled iron was selected for an exhibit in Germany.
The sculpture is made up of a solid sphere of radius 0.5 m and a solid pyramid of a height 1.2 m with a square base of sides 1 m.

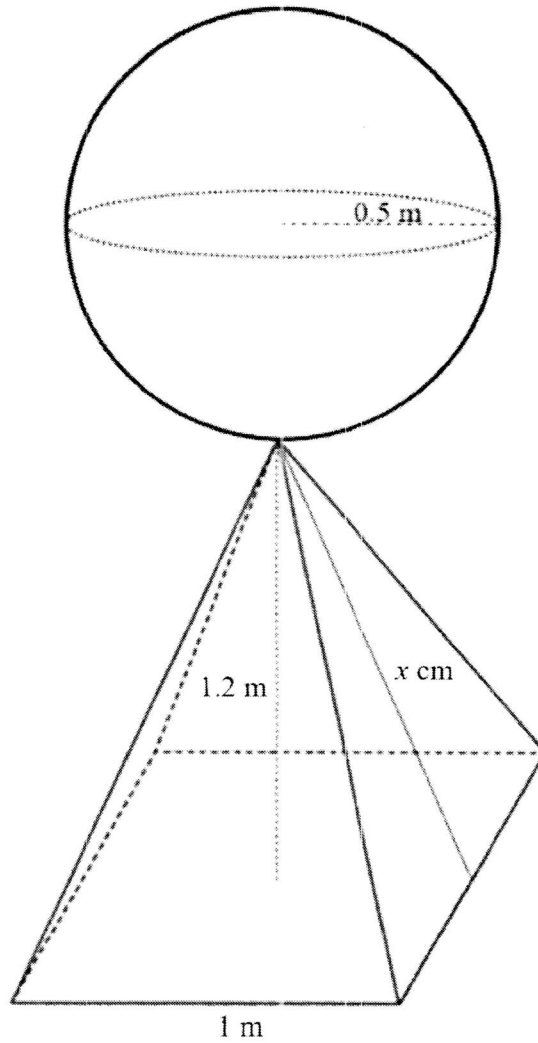

- (a) Calculate the volume of recycled iron used to make this sculpture.

Answer m^3 [3]

- (b) The slant height of the pyramid is x cm.
Find the value of x .

Answer $x =$ [2]

- (c) Ryan must paint the outer surface of the sculpture.
1 litre of paint can cover 3 m^2 .
Given that paint is sold in 2-litre containers, he buys 2 such tins.
By showing your working clearly, justify whether Ryan has bought enough paint to paint the outer surface of the sculpture.

Answer Ryan bought enough paint because

.....
..... [4]

End Of Paper



ZHONGHUA SECONDARY SCHOOL
END-OF-YEAR EXAMINATION 2023
SECONDARY 2 NORMAL (ACADEMIC)

CANDIDATE NAME	CLASS	INDEX NUMBER

MATHEMATICS SYLLABUS A

4045

29 September 2023

Candidates answer on the Question Paper.

2 hours

READ THESE INSTRUCTIONS FIRST

Write your name, class and index number on all the work you hand in.
Write in dark blue or black pen.
You may use an HB pencil for any diagrams or graphs.
Do not use paper clips, glue or correction fluid.

Answer **all** the questions.

The number of marks is given in brackets [] at the end of each question or part question.

If working is needed for any question it must be shown with the answer.

Omission of essential working will result in loss of marks.

The total of the marks for this paper is **70**.

The use of an approved scientific calculator is expected, where appropriate.

If the degree of accuracy is not specified in the question and if the answer is not exact, give the answer to three significant figures. Give answers in degrees to one decimal place.

For π , use either your calculator value or 3.142.

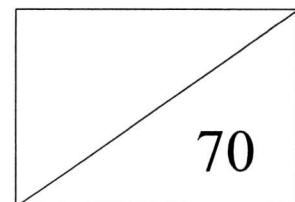

Set by: Mr Brandon Choy

Vetted by: Ms June Yeo & Mr Francis Tan

This document consists of **19** printed pages and **1** blank page.

Mathematical Formulae*Mensuration*

Curved surface area of a cone = $\pi r l$

Surface area of a sphere = $4\pi r^2$

Volume of a cone = $\frac{1}{3}\pi r^2 h$

Volume of a sphere = $\frac{4}{3}\pi r^3$

Answer **all** the questions.

1 Simplify $\frac{6y}{x} \times \frac{2}{3xy^2}$.

Give your answer as a single fraction in its simplest form.

$$\frac{6y}{x} \times \frac{2}{3xy^2}$$

$$= \frac{12y}{3x^2y^2}$$

$$= \frac{4}{x^2y}$$

4 seen - A1

x^2y seen - A1

Answer [2]

2 Express as a single fraction, in its simplest form, $\frac{2}{5}x - \frac{5(2-x)}{4}$.

$$\frac{2}{5}x - \frac{5(2-x)}{4}$$

$$= \frac{2x}{5} - \frac{10-5x}{4}$$

$$= \frac{4(2x) - 5(10 - 5x)}{20} \quad \boxed{\text{M1}}$$

$$= \frac{8x - 50 + 25x}{20}$$

$$= \frac{33x - 50}{20} \quad \boxed{\text{A1}}$$

Answer [2]

- 3 An **open** cone has a circular top of diameter 12 cm and a slant height of 7 cm. Calculate its curved surface area, giving your answer correct to 2 significant figures.

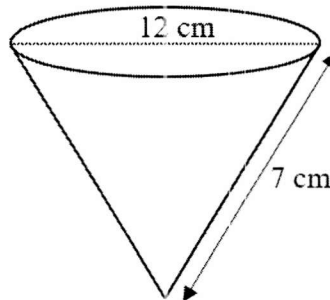

$\pi \left(\frac{12}{2}\right)7$ [radius & slant length must be correct values - M1] = 130 [A1] (3. s. f.)

Answer cm² [2]

- 4 (a) Solve the inequality $-5n < 14$.

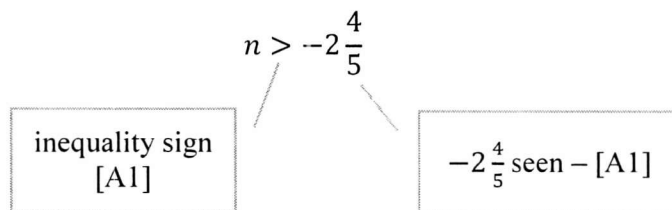

Answer [2]

- (b) Write down the smallest integer value for n .

Answer -2 [A1] [1]

5 Expand and simplify each of the following.

(a) $(3 - 2w)(3 + 2w)$

Answer $\underline{9 - 4w^2}$ [A1] [1]

(b) $(4p + 1)^2$

$$\begin{aligned} &(4p + 1)^2 \\ &= (4p + 1)(4p + 1) \\ &= (4p)^2 + 2(4p) + 1^2 \text{ [M1] or use of multiplication frame} \\ &= 16p^2 + 8p + 1 \text{ [A1]} \end{aligned}$$

Answer $\underline{16p^2 + 8p + 1}$ [A2] [2]

6 Solve $\frac{d-1}{2} - \frac{6-5d}{3} = 2$.

$$\frac{3(d-1) - 2(6-5d)}{6} = 2$$

$$\frac{3d - 3 - 12 + 10d}{6} = 2$$

$$\frac{13d - 15}{6} = 2$$

$13d - 15 = 12$ [cross-multiplication - M1] or multiplying equation by 6 throughout

$13d = 27$ [M1]

$d = \frac{27}{13}$ [exact answer - A1]

Answer $d = \underline{\hspace{2cm}}$ [3]

- 7 The diagram shows a shape with all the lengths given in centimetres.

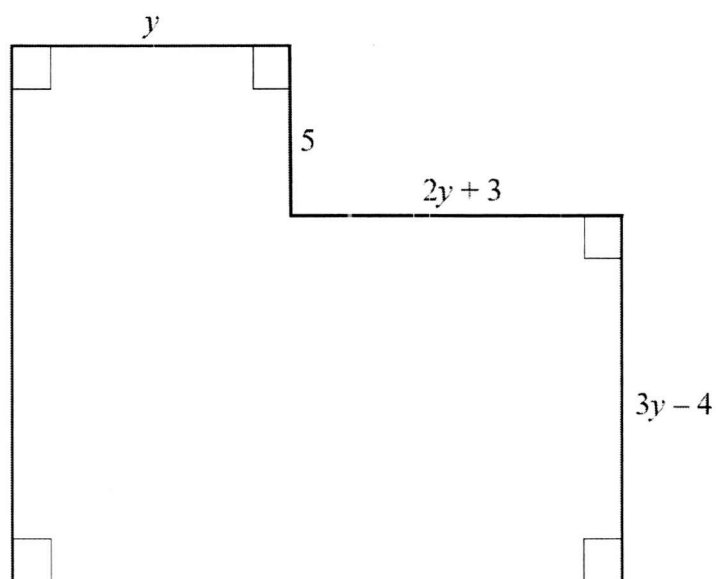

Find an expression, in terms of y , for the area of the shape.

$$5y + (3y - 4)(3y + 3) = 5y + 9y^2 + 9y - 12y - 12 = 9y^2 - 2y - 12 \text{ [A1]}$$

Correct expansion of quadratic expression – M1

Formation of quadratic expression – M1

Answer cm² [3]

8 Given that F is inversely proportional to the **cube** of R and $R = 2$ when $F = 4$, find

(a) an equation connecting F and R ,

$$FR^3 = 4(2^3)$$

$$FR^3 = 4(2^3)$$

M1

$$FR^3 = 32 \text{ [A1]}$$

Answer [2]

(b) the value of R when $F = 0.5$.

$$0.5R^3 = 32$$

$$R^3 = 64$$

Answer $R =$ 4 [A1] [1]

- 9 The diagram shows the sketch of a triangle ABC .

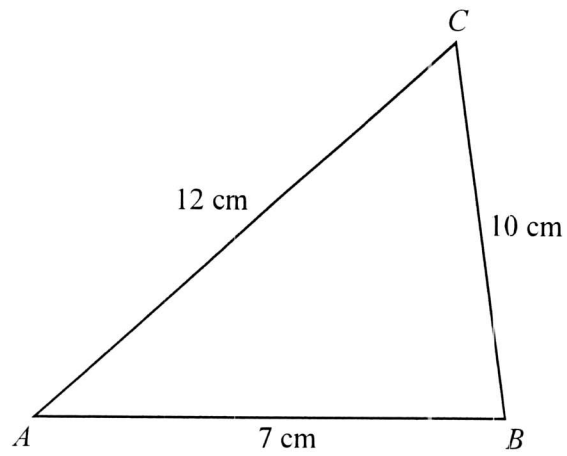

- (a) Construct an accurate full-sized drawing of triangle ABC .

Answer

[2]

- (b) Measure angle BAC .

Answer

.....

[1]

10 The scale of a map is given as 1 : 20 000.

(a) Rewrite the scale in the form 1 cm to x km.

Answer 1 : 0.2 [A1] [1]

(b) A paddy field on the map is 10 cm long.
Find the actual length of the field in kilometres.

Answer 2 [A1] km [1]

(c) A swamp has an area of 5 km².
Find the area of the swamp on the map in square centimetres.

1 cm represents 0.2 km

1 cm² represents 0.04 km² [M1]

0.04 km² is represented by 1 cm²

5 km² is represented by 125 [A1] cm²

Answer cm² [2]

- 11 Trapezium $ABCD$ is similar to trapezium $PQRS$.
 $CD = 3$ cm, $QR = 3.7$ cm, $RS = 6$ cm and angle $BCD = 47^\circ$.

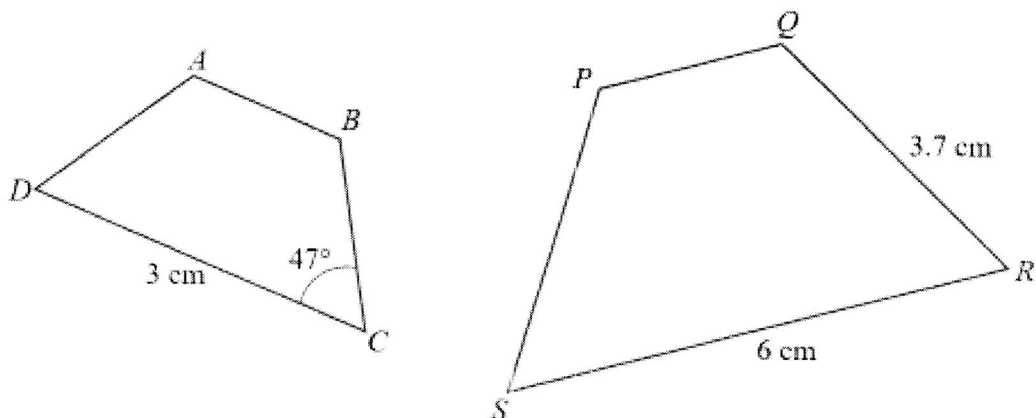

- (a) Find the length of BC .

$$3.7 \div 2 \text{ [2 - seen [M1]]} = 1.35 \text{ [A1] cm}$$

Answer cm [2]

- (b) Find angle PQR .

$$\text{angle } ABC = 133^\circ \text{ [M1]}$$

Answer 133° [A1] [2]

- 12 The masses (in grams) of 20 eggs are shown in the stem-and-leaf diagram below.

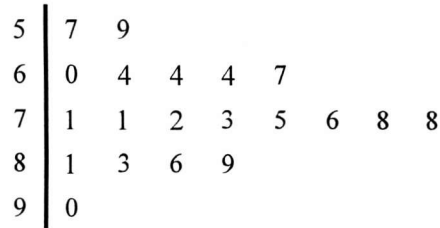

Key
1 | 2 means 12 grams

- (a) What is the difference in mass between the lightest and the heaviest egg?

Answer 33 [A1] grams [1]

- (b) State the modal mass of the eggs.

Answer 64 [A1] grams [1]

- (c) Find the median mass of the eggs.

$$\frac{72+73}{2} \text{ [M1]}$$

$$= 72.5 \text{ [A1]}$$

Answer 72.5 [A2] grams [2]

13 Factorise completely

(a) $35wy - 7w^2y$,

$7wy$ [A1] $5 - w$ [A1]

Answer $7wy(5 - w)$ [2]

(b) $3x^2 - 16x + 5$,

$(3x - 1)$ [A1] $(x - 5)$ [A1]

Answer [2]

(c) $2x^2 - 2$.

$2(x^2 - 1)$ [M1] = $2(x - 1)(x + 1)$ [A1]

Answer [2]

- 14 (a) The exterior angle of a regular polygon is 45° .
How many sides does the polygon have?

$360^\circ \div 45^\circ$ [M1] = 8 [A1]

Answer [2]

- (b) The diagram shows a polygon.
 DEF is a straight line.

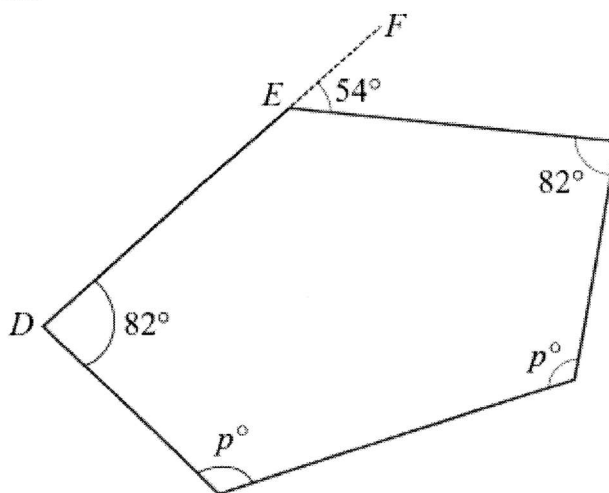

- (i) State the name of the polygon.

Spelling must be correct

Answer pentagon [B1] [1]

- (ii) Find the value of p .

$(180 - 54) + 82 + 82 + p + p = 180(5 - 2)$

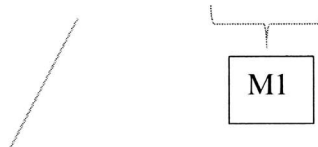

Formation of equation – [M1]

Answer 125 [A1] [3]

- 15 The histogram shows the results of a survey conducted to find the number of phone calls made using handphones by a group of people in a certain month. .

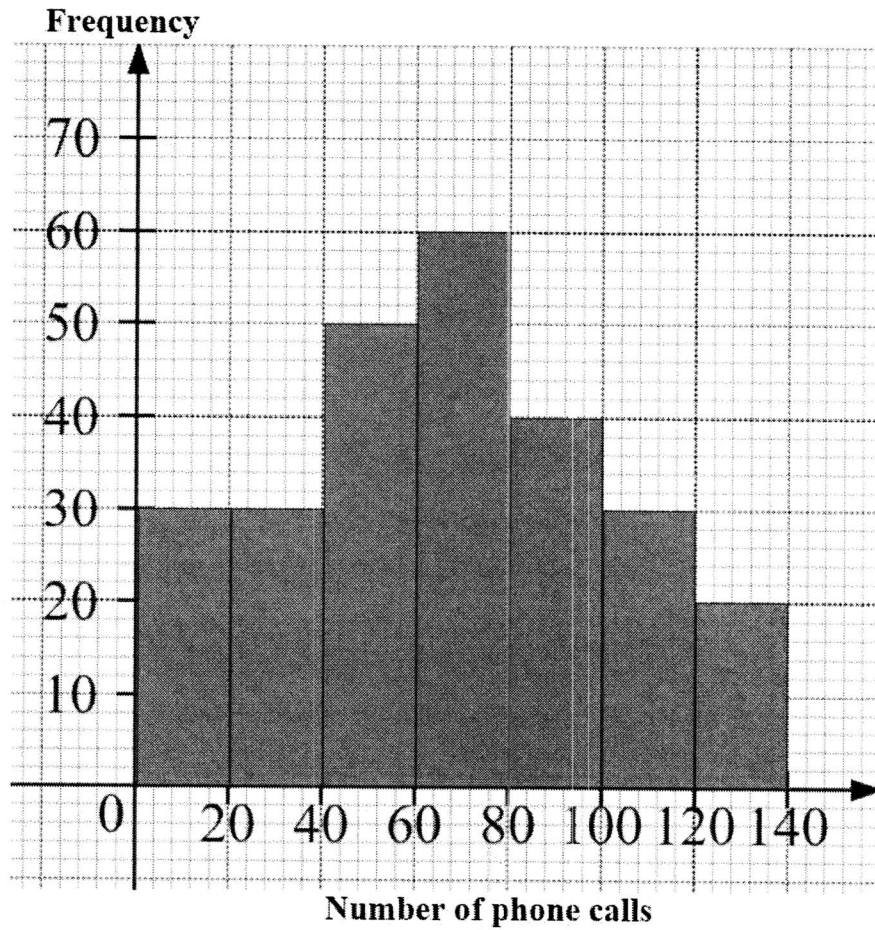

- (a) How many people were involved in the survey?

Answer 260 [A1] people [1]

- (b) Find the percentage of people who made more than 100 phone calls in that month.

$$\frac{30+20}{260} [M1] = 19.2\% \text{ (3 s. f.) [A1]}$$

Answer % [2]

- (c) Calculate an estimate of the mean number of phone calls.

$$\frac{10 \times 30 + 30 \times 30 + 50 \times 50 + 70 \times 60 + 90 \times 40 + 110 \times 30 + 120 \times 20}{260} = 66.2 \text{ (3 s. f.) [A1]}$$

Mid values seen – [M1]

Answer phone calls [2]

- (d) Suggest why a dot diagram is not an appropriate statistical diagram to represent the data.

Answer not practical to use a dot diagram for 260 data which is
 relatively a large number [A1] or any suitable suggestion

..... [1]

- 16 Line P is shown on the grid.
The equation of line P is $3x + 2y = 6$.

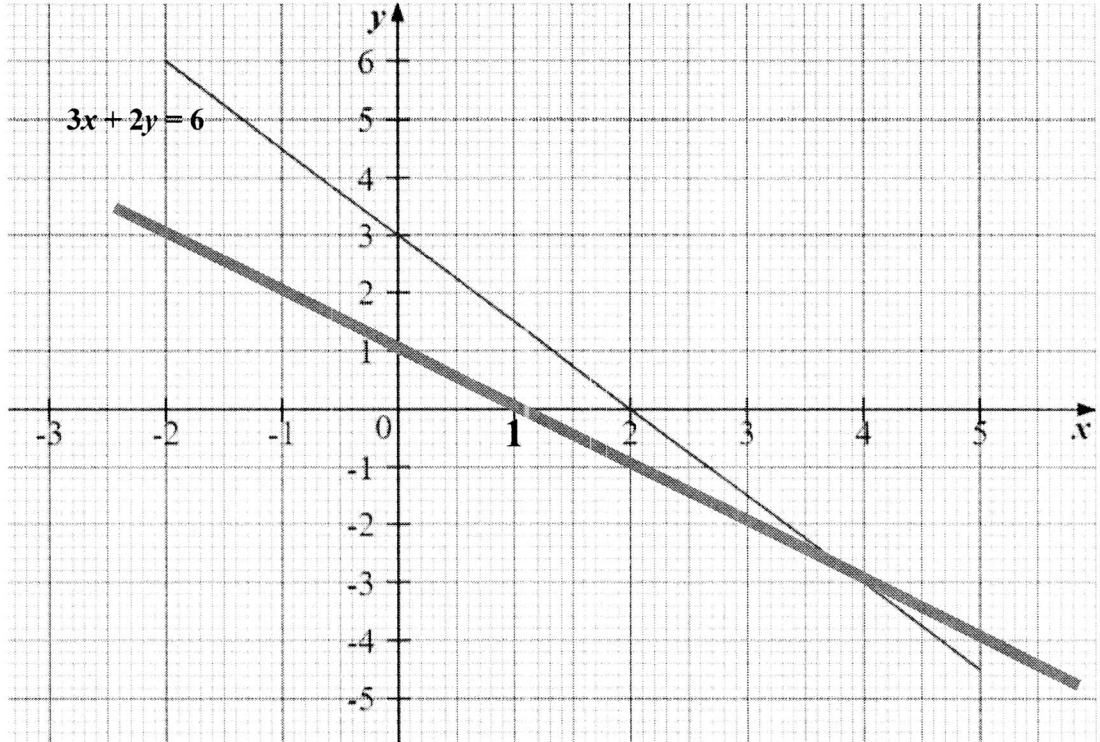

- (a) (i) Complete the table of values for $y = 1 - x$.

x	-2	0	3	5
y	3	1	-2	-4

[1]

- (ii) Draw the line $y = 1 - x$.

[2]

- (b) Find the solution of these simultaneous equations.

$$\begin{aligned} 3x + 2y &= 6 \\ y &= 1 - x \end{aligned}$$

Answer $x = \underline{\quad 4 \text{ [A1]} \quad}$

$y = \underline{\quad -3 \text{ [A1]} \quad}$ [2]

- (c) (i) Find the gradient of line P .

Answer -1 [A1] [1]

- (ii) Write down the y -intercept of the line $y = 1 - x$.

Answer 1 [B1] [1]

- 17 Ryan is a local sculptor and his latest sculpture made from recycled iron was selected for an exhibit in Germany.
The sculpture is made up of a solid sphere of radius 0.5 m and a solid pyramid of a height 1.2 m with a square base of sides 1 m.

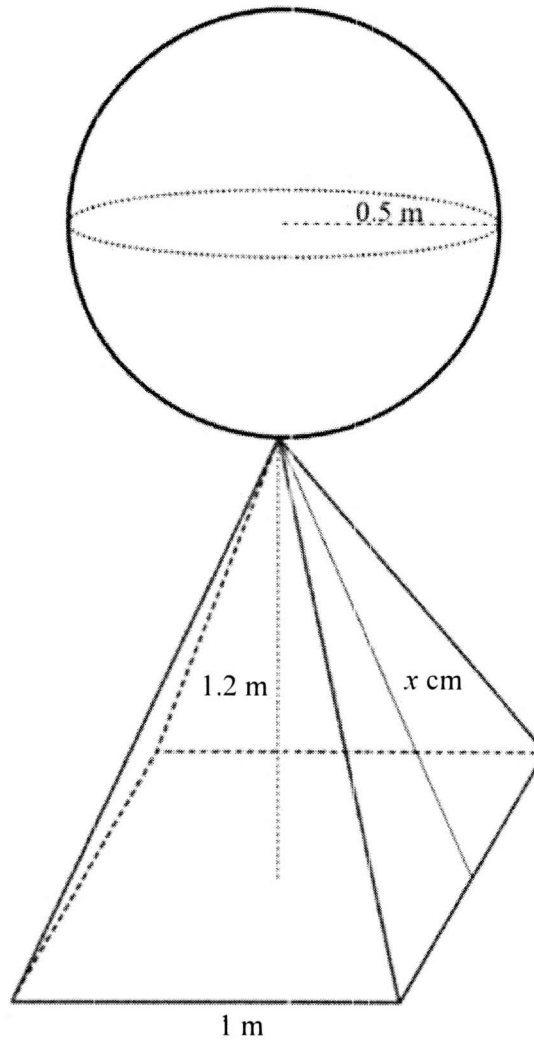

- (a) Calculate the volume of recycled iron used to make this sculpture.

$$\frac{1}{3} \times 1.2 \times 1^2 = 0.4 \text{ m}^3 \text{ [M1]}$$

$$\frac{4}{3} \times \pi \times 0.5^3 = 0.52359 \text{ m}^3 \text{ [M1]}$$

Answer 0.924 (3 s. f.) [A1] m³ [3]

- (b) The slant height of the pyramid is x cm.
Find the value of x .

$$x^2 + 0.5^2 = 1.2^2 \text{ [M1]}$$

$$x = 1.19 \text{ [A1]}$$

Answer $x =$ [2]

- (c) Ryan must paint the outer surface of the sculpture.
1 litre of paint can cover 3 m^2 .
Given that paint is sold in 2-litre containers, he buys 2 such tins.
By showing your working clearly, justify whether Ryan has bought enough paint to paint the outer surface of the sculpture.

$$4\pi 0.5^3 \text{ [M1]} = 0.125\pi \text{ m}^2$$

$$1^2 + 4\left(\frac{1}{2} \times 1 \times 1.19\right) = 3.38 \text{ m}^2 \text{ [M1]}$$

$$\text{Outer surface} = (0.125\pi + 3.38) \text{ m}^2$$

3 m^2 is covered by using 1 litre of paint

$(0.125\pi + 3.38) \text{ m}^2$ is painted by 3.7727 l of paint [M1]

amount of paint brought of $= 2 \times 2 = 4 \text{ m}^2$

Answer Ryan did bought enough paint because

$$\text{.....} \quad 3.77 < 4 \text{ [A1]} \quad \text{.....}$$

..... [4]

End Of Paper

