

*Visit*

**FREETESTPAPER.com**

*for more papers*



Website: [freetestpaper.com](http://www.freetestpaper.com)



[Facebook.com/freetestpaper](https://www.facebook.com/freetestpaper)



[Twitter.com/freetestpaper](https://www.twitter.com/freetestpaper)



Answer **all** the questions.

1 In the diagram below, construct

(a) an angle bisector at angle  $ACB$ ,

[1]

(b) a perpendicular bisector at line  $AB$ .

[1]

*Answer*

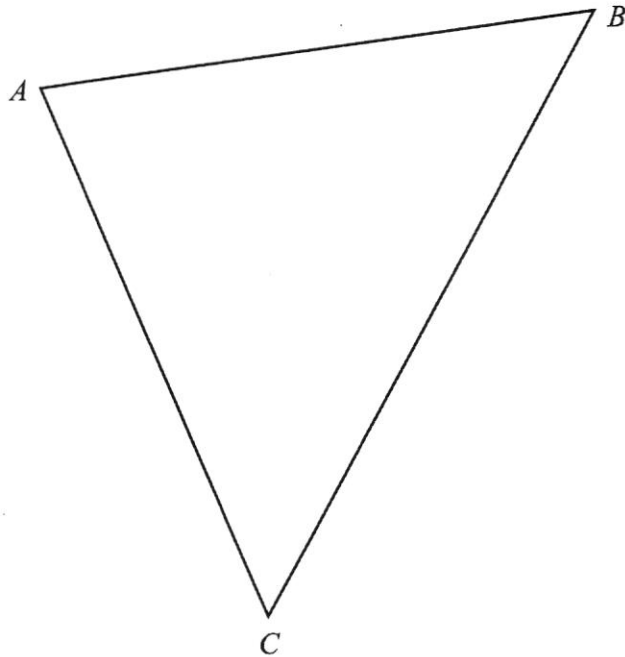

2 The tables below are similar. Find the height,  $h$  of the smaller table.

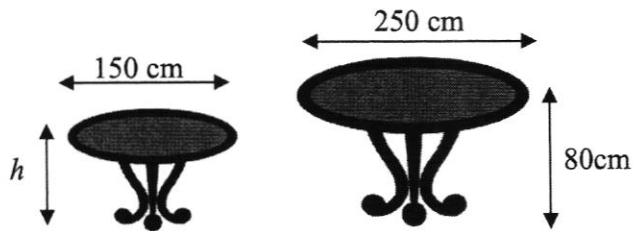

*Answer* ..... cm [2]

3 Given that  $f = 7$ ,  $g = 4$  and  $h = -1$ , find the value of

(a)  $f(\sqrt{g} - h)$ ,

*Answer* ..... [1]

(b)  $\frac{gh^2}{f+3}$ .

*Answer* ..... [1]

---

4 Express  $\frac{4x+1}{5} + \frac{3-x}{4}$  as a single fraction in its simplest form.

*Answer* ..... [2]

---

5 Solve  $\frac{3x}{5} = 2$ .

*Answer*  $x = \dots\dots\dots$  [2]

---

- 6 The following dot diagram represents the number of errors made in each report typed by each data entry personnel in a company.

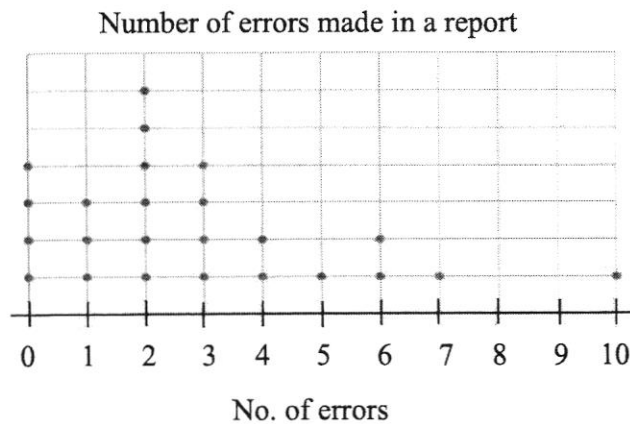

- (a) How many data entry personnel are there in the company?

*Answer*  $\dots\dots\dots$  [1]

- (b) Write down the most common number of errors made.

*Answer*  $\dots\dots\dots$  [1]

---

- 7 At a carnival, a fair spinner was used in a game stall. The spinner is divided into equal sectors. Prizes are awarded to participants if they spin a score that is 4 points or more. Aden spins the wheel once to obtain a score.

Find the probability that Aden

- (a) obtains a score of 6,

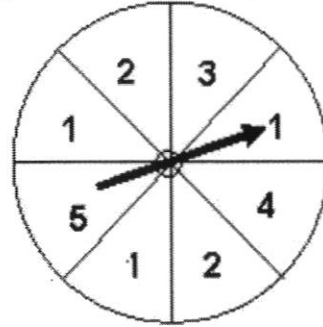

Answer ..... [1]

- (b) obtains a score of even numbers,

Answer ..... [1]

- (c) wins a prize for his spin.

Answer ..... [1]

- 8 In the diagram,  $S$  is on  $PR$  such that  $QS$  is perpendicular to  $PR$ . It is given that  $PQ = 13$  cm,  $PS = 5$  cm and  $SR = 16$  cm.

Find

- (a) the length of  $QS$ ,

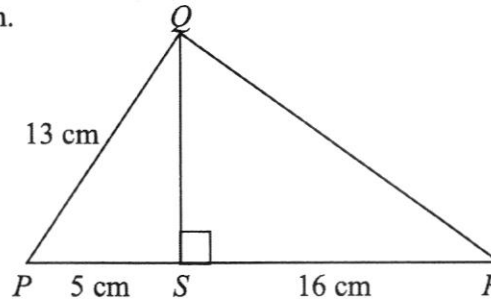

Answer ..... cm [2]

- (b) the length of  $QR$ .

Answer ..... cm [2]

- 9 In the figure below,  $PQRS$  is congruent to  $XYZS$ . It is given that  $PQ = 13$  cm,  $PS = 11$  cm,  $SZ = 9$  cm, angle  $SPQ = 94^\circ$ , angle  $PQR = 72^\circ$  and angle  $QRS = 78^\circ$ .

Find

- (a) the length of  $RX$ ,

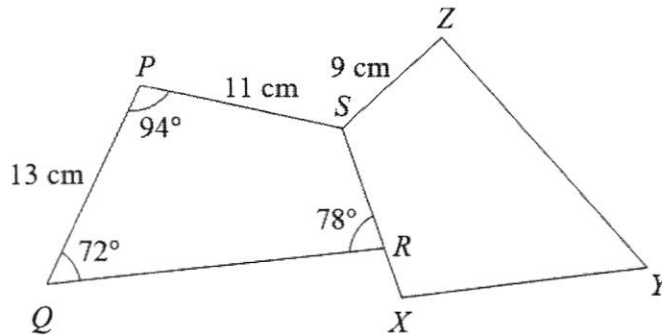

Answer ..... cm [2]

- (b) the angle  $XSZ$ .

Answer angle  $XSZ$  .....  $^\circ$  [2]

- 10 (a) 5 men can build a sailing boat in 18 days. How many men are needed to build the same sailing boat in 10 days?

Answer ..... men [2]

- (b) Bernice deposits \$68 000 in a bank that pays simple interest of 5.8% per annum. Find the amount she has at the end of 4 years.

Answer \$..... [3]

- 11 In 2010, Mr Chandra bought a house for \$180 000. The market value of the house between the years 2010 and 2015 is represented in the graph below.

Market value (in thousand dollars)

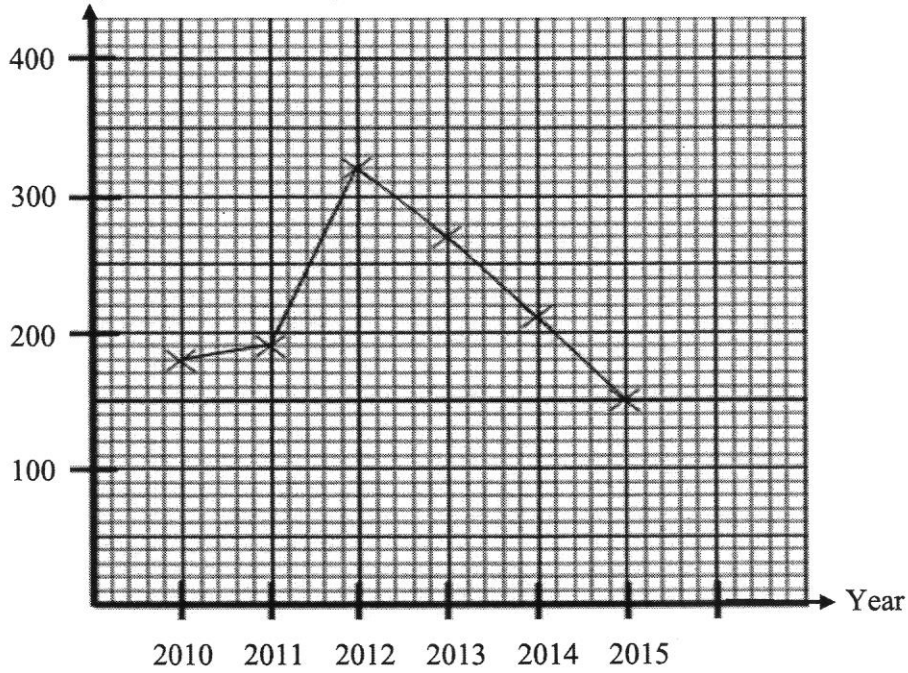

- (a) What was the market value of the house in the year 2014?

Answer \$ ..... [1]

- (b) In which year did the house have the greatest market value?

Answer Year ..... [1]

- (c) When was the market value of the house 1.5 times the purchase value?

Answer Year ..... [2]

- (d) Did Mr Chandra earn / lose money when he sold his house in 2015? How much did he earn / lose? (Circle your answer)

Answer \$ ..... [1]

Earn / Lose [1]

12 The diagram shows the shape of a chocolate bar in the shape of a triangular prism.

(a) Calculate the volume of the chocolate bar.

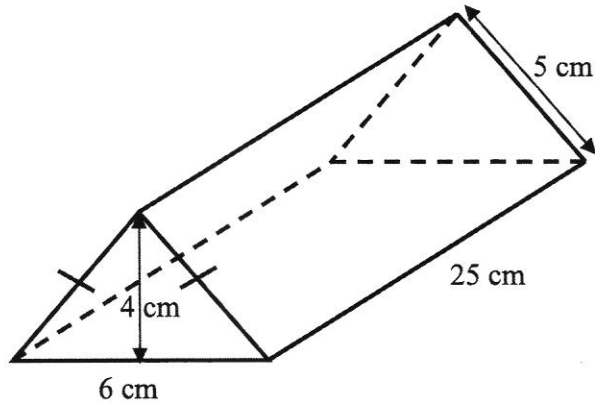

Answer ..... cm<sup>3</sup> [2]

(b) Calculate the surface area of aluminium foil needed to wrap the chocolate bar fully.

Answer ..... cm<sup>2</sup> [2]

(c) If one sheet of aluminum foil is 50 cm<sup>2</sup>, how many sheets of aluminum foil are needed to wrap the chocolate bar fully?

Answer ..... [2]



**NORTH VISTA SECONDARY SCHOOL**  
**END-OF-YEAR EXAMINATION 2018**

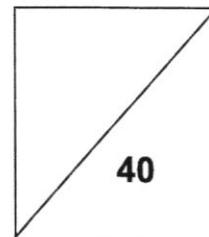

**NAME:** \_\_\_\_\_ (       )       **CLASS:** \_\_\_\_\_

**SUBJECT: MATHEMATICS (PAPER 2)**

**DATE: 8 OCTOBER 2018**

**LEVEL/STREAM: SECONDARY 2 NORMAL (TECHNICAL)**

**TIME: 1 HOUR 15 MINUTES**

**READ THESE INSTRUCTIONS FIRST**

Write your register number and name on all the work you hand in.  
Write in dark blue or black pen.  
You may use a pencil for any diagrams or graphs.  
Do not use staples, paper clips, highlighters, glue or correction fluid.

Answer **all** questions.  
The number of marks is given in brackets [ ] at the end of each question or part question.

If working is needed for any question it must be shown in the space below that question.  
Omission of essential working will result in loss of marks.  
The total of the marks for this paper is 40.

The use of an approved scientific calculator is expected, where appropriate.  
If the degree of accuracy is not specified in the question and if the answer is not exact, give the answer to three significant figures. Give answers in degrees to one decimal place.  
For  $\pi$ , use either your calculator value or 3.142

<i>For Examiner's Use</i>	
<b>Category</b>	<b>Question No.</b>
Accuracy	
Brackets	
Fractions	
Units	
Others	
<b>Marks Deducted</b>	

Answer **all** the questions.

- 1 The diagram below shows a set of game balls. The blue balls are numbered 1 to 6. The red balls are numbered 7 to 12. There are two white balls without any number.

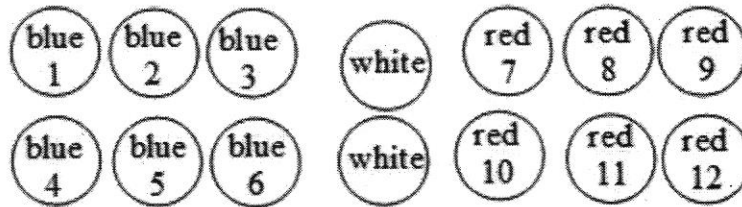

All the balls are placed in a black bag and one ball is drawn randomly from the bag. Find the probability of drawing

- (a) a ball that is not red,

*Answer* ..... [1]

- (b) a white ball with an even number,

*Answer* ..... [1]

- (c) a blue ball or a ball with an odd number.

*Answer* ..... [1]

- 2 Simplify  $3(6x + y) - (x + y)$ .

*Answer* ..... [3]

- 3 Mr David drives for 4 hours 35 minutes from Singapore to Kuala Lumpur. He stops at Kuala Lumpur for 3 hours 20 minutes. He then drives from Kuala Lumpur to Penang for 3 hours 45 minutes.

(a) How long did the journey from Singapore to Penang take? Give your answer in hours and minutes.

*Answer* .....h.....min [1]

(b) The distance from Singapore to Kuala Lumpur is 410 km and the distance from Kuala Lumpur to Penang is 350 km. Find the average speed, in km/h, of Mr David for his journey from Singapore to Penang.

*Answer* ..... km/h [2]

- 4 Anne bought a T-shirt and a dress. The price of a dress is \$35 more than the price of a T-shirt. Let the price of the T-shirt be \$ $x$ .

(a) Express the price of the dress in terms of  $x$ .

*Answer* \$..... [1]

(b) If the total cost of a T-shirt and a dress is \$200, form an equation in terms of  $x$ .

*Answer* ..... [1]

(c) Solve the equation and find the price of the dress.

*Answer* \$..... [2]

- 5 (a) The diagonal,  $d$ , gives the screen size of a laptop computer.  
Calculate  $d$  for the rectangular screen of 26 cm by 21 cm shown below. Give your answer correct to the nearest whole number.

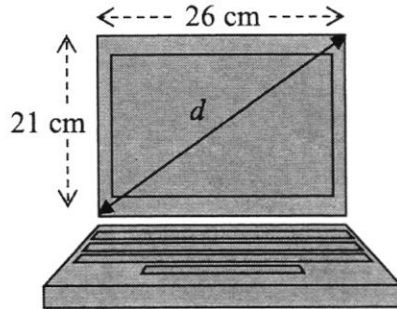

Answer ..... cm [2]

- (b) A transit was used to calculate the height of an object.  
Find the height of the tree using the dimensions given. Give your answer to 2 decimal places.

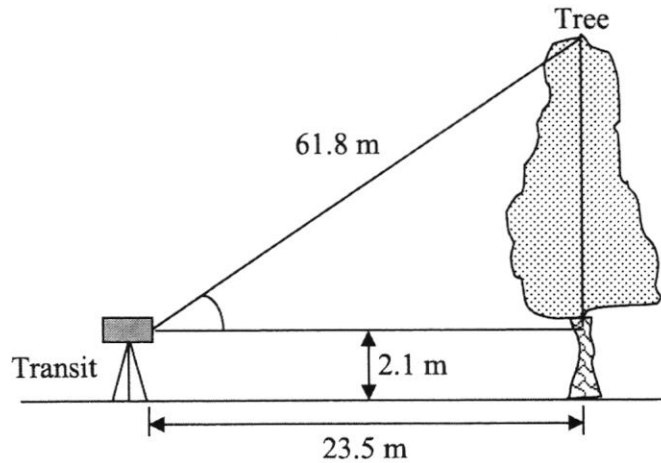

Answer ..... m [3]

- 6 (a) Complete the table of values for  $y = 2x + 1$  below.

*Answer*

[1]

$x$	-3	-1	0	2
$y$		-1	1	

- (b) On the axes, plot and label the graph of  $y = 2x + 1$ .

[2]

*Answer (b) and (c)*

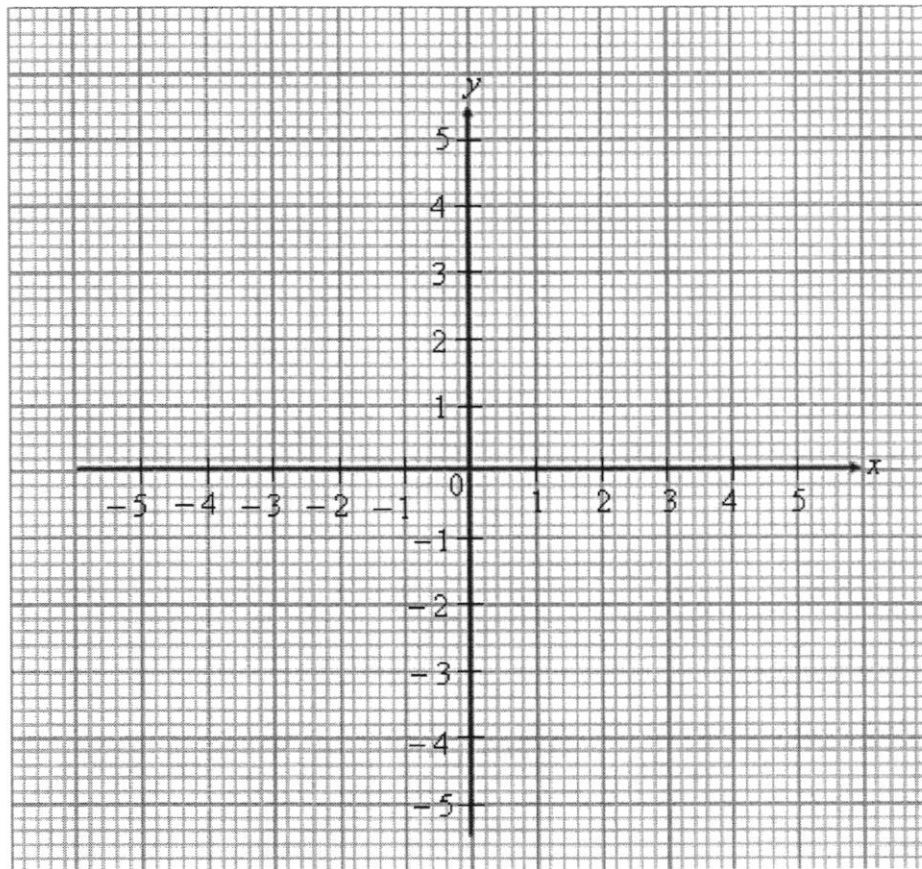

- (c) On the graph, draw and label the line  $y = -3$ .

[1]

- (d) State the coordinates where the two lines intercept each other.

*Answer* (....., .....)

[1]

- 7 A 6-sided die is thrown  $x$  times and the results are shown in the table below.

No. shown on the die	1	2	3	4	5	6
Frequency	8	7	5	2	3	4

Find

- (a)  $x$ ,

*Answer* ..... [1]

- (b) the mode number shown on the die,

*Answer* ..... [1]

- (c) the median number shown on the die,

*Answer* ..... [1]

- (d) the mean number shown on the die.

*Answer* ..... [2]

---

- 8 The table below shows part of a utility bill.

<b>CURRENT MONTH CHARGES</b>	<i>Usage</i>	<i>Rate (\$)</i>	<i>Amount (\$)</i>	<i>Total (\$)</i>
<b>Electricity Services</b>				
Electricity Estimated on 29-06-2015				
Electricity	627 kWh	0.2087	(a)	
<b>Water Services by Public Utilities Board</b>				
Water Estimated on 29-06-2015				
Water	22.7 Cu M	1.1700	26.56	
Waterborne Fee	22.7 Cu M	0.2803	6.36	
Sanitary Appliance Fee	3 Fittings	2.8037	8.41	
<b>Refuse Removal by SembWaste Pte Ltd</b>				
Refuse	1 Qty	7.00	7.00	
<b>Water Conservation Tax</b>				
	\$26.56	30%	(b)	
<b>Total Charges</b>				
<b>Goods &amp; Services Tax</b>				
		7%	(c)	
<b>Total Current Charges Inclusive of GST</b>				<b>\$200.26</b>

Calculate the missing  
(a) electricity charges,

Answer \$ ..... [2]

(b) water conservation tax,

Answer \$ ..... [2]

(c) GST charges, given that it is included in the total amount of \$200.26.

Answer \$ ..... [2]

9 The picture shows the wheel and the passenger capsules of the Singapore Flyer.

(a) Each passenger capsule is a cylinder of radius 2 m and length 7 m.

(i) Using  $\pi = 3.142$ , calculate the volume of each capsule.

Leave your answer to the nearest whole number.

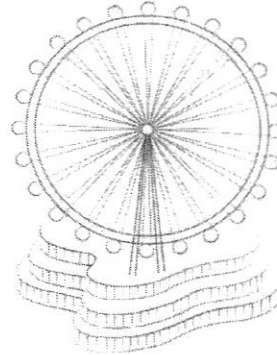

Answer ..... m<sup>3</sup> [2]

(ii) For safety reason, each passenger requires a volume of 3.05 m<sup>3</sup> of air in a capsule. What is the largest number of passengers that each capsule can carry?

Answer ..... [2]

(b) Each capsule travels in a circle of radius 75 m. How far does a capsule travel in one revolution?

Answer ..... m [2]

Sec 2NT End-of-Year Exam 2018 Mathematics Paper 1

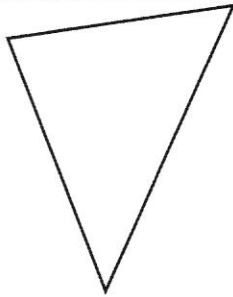
	Answer	Marking Scheme
1 (a) (b)		B1 B1
2	$h = 80 \times \frac{150}{250} = 48$	M1, A1
3 (a) (b)	21 $\frac{2}{5}$	B1 B1
4	$\frac{4x+1}{5} + \frac{3-x}{4} = \frac{4(4x+1)+5(3-x)}{20}$ $= \frac{16x+4+15-5x}{20} = \frac{11x+19}{20}$	M1 A1
5	$\frac{3x}{5} = 2$ (multiply both sides by 5) $3x = 10$ $x = 3\frac{1}{3}$	M1 A1
6 (a) (b)	24 2	B1 B1
7 (a) (b) (c)	0 $\frac{3}{8}$ $\frac{1}{4}$	B1 B1 B1
8 (a) (b)	QS = $\sqrt{13^2 - 5^2} = 12$ cm QR = $\sqrt{16^2 + 12^2} = 20$ cm	M1, A1 M1, A1

9 (a)	$11 - 9 = 2 \text{ cm}$	M1, A1
(b)	$360 - 94 - 78 - 72 = 116^\circ$	M1, A1
10 (a)	$5 \times \frac{18}{10} = 9$	M1, A1
(b)	$68000 \times 5.8\% \times 4 = 15776$ Total amount = \$83 776	M1, A1 B1
11 (a)	\$210 000	B1
(b)	Year 2012	B1
(c)	$180\,000 \times 1.5 = \$270\,000$ Year 2013	M1 A1
(d)	$150\,000 - 180\,000 = \$30\,000$ Lost	M1 A1
12 (a)	$\frac{1}{2} \times 6 \times 4 \times 25 = 300 \text{ cm}^3$	M1, A1
(b)	$(5 + 5 + 6) \times 25 + 2\left(\frac{1}{2} \times 6 \times 4\right)$ $= 424 \text{ cm}^2$	M1 for seeing $(5 + 5 + 6) \times 25$ or $2\left(\frac{1}{2} \times 6 \times 4\right)$ A1
(c)	$424 \div 50 = 8.48$ 9 sheets	M1 A1

Sec 2NT End-of-Year Exam 2018 Mathematics Paper 2

	Answer	Marking Scheme
1 (a)	$\frac{4}{7}$	B1
(b)	0	B1
(c)	$\frac{9}{14}$	B1
2	$18x + 3y - (x + y)$ $= 18x + 3y - x - y$ $= 17x + 2y$	M1 M1 A1
3 (a)	11 h 40 min	B1
(b)	$(410 + 350) \div 11 \frac{40}{60} = 65 \frac{1}{7}$ km/h	M1, A1
4 (a)	$x + 35$	B1
(b)	$2x + 35 = 200$	A1
(c)	$2x + 35 = 200$ $2x = 165$ $x = 82.5$ Dress = \$117.50	M1 A1
5 (a)	$\sqrt{21^2 + 26^2} = 33.4$ $= 33$ (nearest whole number)	M1 A1
(b)	$\sqrt{61.8^2 - 23.5^2} = 57.1578$ $57.1578 + 2.1 = 59.2578$ $= 59.26$ m (2.d.p)	M1 M1 A1

6 (a)	-5, 5	B1
(b)		B2, -1m if no label or only 1 point plotted wrongly
(c)		B1
(d)	(-2, -3)	B1
7 (a)	29	B1
(b)	1	B1
(c)	2	B1
(d)	$(1 \times 8 + 2 \times 7 + 3 \times 5 + 4 \times 2 + 5 \times 3 + 6 \times 4) \div 29 = 2 \frac{26}{29}$	M1, A1
8 (a)	$627 \times 0.2087 = \$130.85$	M1, A1
(b)	$26.56 \times 30\% = \$7.97$	M1, A1
(c)	$200.26 \div 107 \times 7 = \$13.10$	M1, A1
9(a)(i)	$3.142 \times 2^2 \times 7 = 87.976$ $= 88 \text{ m}^3$ (nearest whole number)	M1 A1
(ii)	$88 \div 3.05 = 28.85$ 28 passenger	M1 A1
(b)	$2 \times 3.142 \times 75 = 471.3 \text{ m}$	M1, A1