

*Visit*

**FREETESTPAPER.com**

*for more papers*



Website: [freetestpaper.com](http://www.freetestpaper.com)



[Facebook.com/freetestpaper](https://www.facebook.com/freetestpaper)



[Twitter.com/freetestpaper](https://www.twitter.com/freetestpaper)



## WOODLANDS RING SECONDARY SCHOOL

---

Name : \_\_\_\_\_ Reg No. \_\_\_\_\_ Class : 2T7

---

**EXAMINATION : END-OF-YEAR EXAMINATION**

**LEVEL : SECONDARY 2 NORMAL TECHNICAL DATE: 02 Oct 2018**

**SUBJECT : MATHEMATICS PAPER: 1**

**DURATION : 1 hour 15 minutes MAX MARKS: 50**

**SETTER(S) : Mrs Sharon Sim Parent's/Guardian's Signature:**

---

### INSTRUCTIONS TO CANDIDATES

Write your name, class and register number on all the work you hand in.

Write in dark blue or black pen in the spaces provided on the Question Paper.

You may use a pencil for any diagrams or graphs.

Do not use staples, paper clips, glue or correction fluid.

Answer **all** questions.

The number of marks is given in brackets [ ] at the end of each question or part question.

If working is needed for any question, it must be shown in the space below the question.

Omission of essential working will result in loss of marks.

The use of an approved scientific calculator is expected, where appropriate.

If the degree of accuracy is not specified in the question, and if the answer is not exact, give the answer to three significant figures. Give answers in degrees to one decimal place.

For  $\pi$ , use either your calculator value or 3.142.

For Examiner's Use

/50

***Mathematical Formulae****Compound interest*

$$\text{Total amount} = P \left( 1 + \frac{r}{100} \right)^n$$

Answer **all** the questions.

1 Write the number 7.98324 correct to

(a) 3 significant figures,

Answer ..... [1]

(b) 1 decimal place.

Answer ..... [1]

2 Write the following in order of size, starting with the **largest**.

$$\frac{8}{13} \quad 0.60 \quad 59\% \quad 0.43$$

Answer ....., ....., ....., ..... [2]  
largest smallest

3 Each week Tim works partly at home and partly in the office.

He divides the time so that the ratio of home hours to office hours is 30 : 70.

(a) Write the ratio 30 : 70 in its simplest form.

Answer ..... [1]

(b) He worked a total of 40 hours each week.

Calculate how many hours he worked

(i) at home and

Answer ..... hours [2]

(ii) in the office.

Answer ..... hours [1]

- 4 The cable car from Mount Faber to Sentosa Island travels a distance of 1650 metres in 15 minutes.

Calculate the average speed of the cable car in

(a) metres per minute and

*Answer* ..... m/min [1]

(b) kilometres per hour.

*Answer* ..... km/h [2]

- 
- 5 (a) Draw the triangle  $ABC$  where  $BC = 7$  cm and  $AC = 9$  cm. [2]

(b) Draw the angle bisector of  $\angle ABC$ . [1]

The line  $AB$  has been drawn for you.

*Answer*

$A$  \_\_\_\_\_  $B$

---

- 6 Triangle X is shown on the grid.

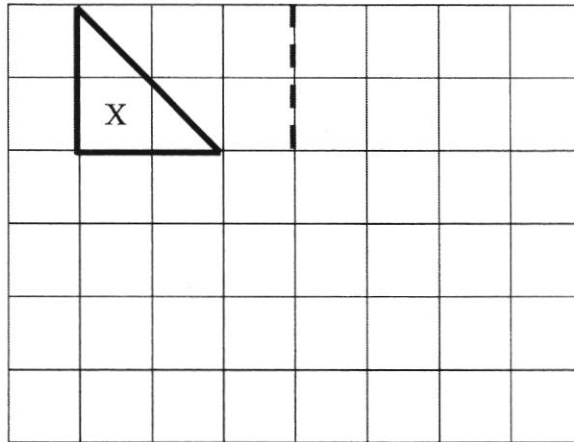

On the grid, draw

- (a) the image of triangle X when reflected along the dotted line, label it Y, [1]  
 (b) a triangle similar to, but not congruent to, triangle X. Label it Z. [1]

- 7 Simplify the following expressions.

(a)  $2x + 3 + 6x$

*Answer* ..... [1]

(b)  $4(x + 3)$

*Answer* ..... [1]

(c)  $2x + \frac{1}{2}x - \frac{2}{3}x$

*Answer* ..... [2]

- 8 When  $a = 0.25$ ,  $b = 3$  and  $c = 6$ , find the value of  $\sqrt{a(b + c)}$ .

Answer ..... [2]

---

- 9 A pack of 500 sheets of photocopying paper is 29.7 cm long, 21 cm wide and 5.3 cm thick.

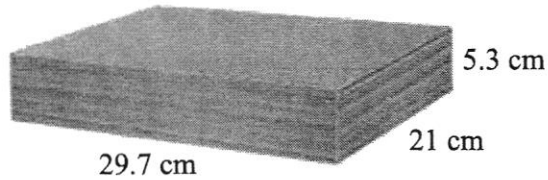

- (a) Calculate the thickness of one sheet of paper.

Answer ..... cm [2]

- (b) Calculate the volume of one pack of paper.

Answer .....  $\text{cm}^3$  [2]

---

- 10 (a) Calculate 85% of \$80.

Answer \$..... [2]

- (b) Express \$10 as a percentage of \$80.

Answer ..... % [2]

---

- 11 The diagram shows two similar triangles,  $ABC$  and  $PQR$ .

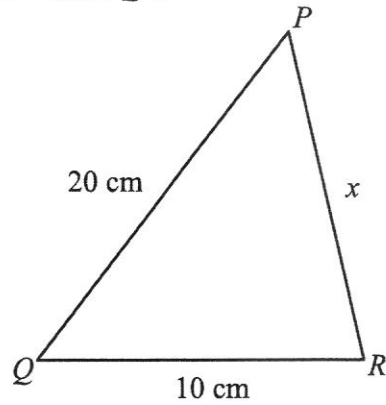
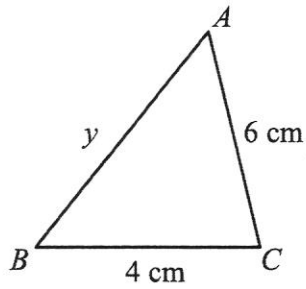

- (a) State the angle from triangle  $PQR$  that corresponds to  $\angle BCA$ .

Answer  $\angle$  ..... [1]

- (b) Write the ratio of  $\frac{BC}{QR}$ .

Answer ..... [1]

- (c) Calculate the value of  
(i)  $x$  and

Answer  $x =$  ..... [2]

- (ii)  $y$ .

Answer  $y =$  ..... [2]

- (d) Hence, calculate the perimeter of triangle  $PQR$ .

Answer ..... cm [1]

- 12 A square,  $ABCD$ , is drawn on the side of a right-angled triangle to form a pentagon.

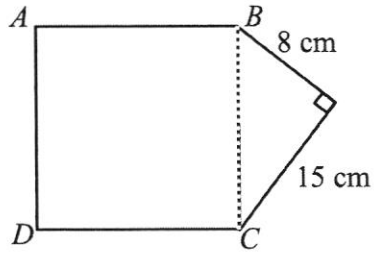

- (a) Calculate the length of side  $BC$  of the right-angled triangle.

*Answer* ..... cm [2]

- (b) Calculate the perimeter of the pentagon.

*Answer* ..... cm [1]

- (c) Calculate the area of the pentagon.

*Answer* .....  $\text{cm}^2$  [3]

---

- 13 Plumber A charges a basic fee for the first hour of a job and a fixed rate for extra time spent. The graph shows plumber A's charges.

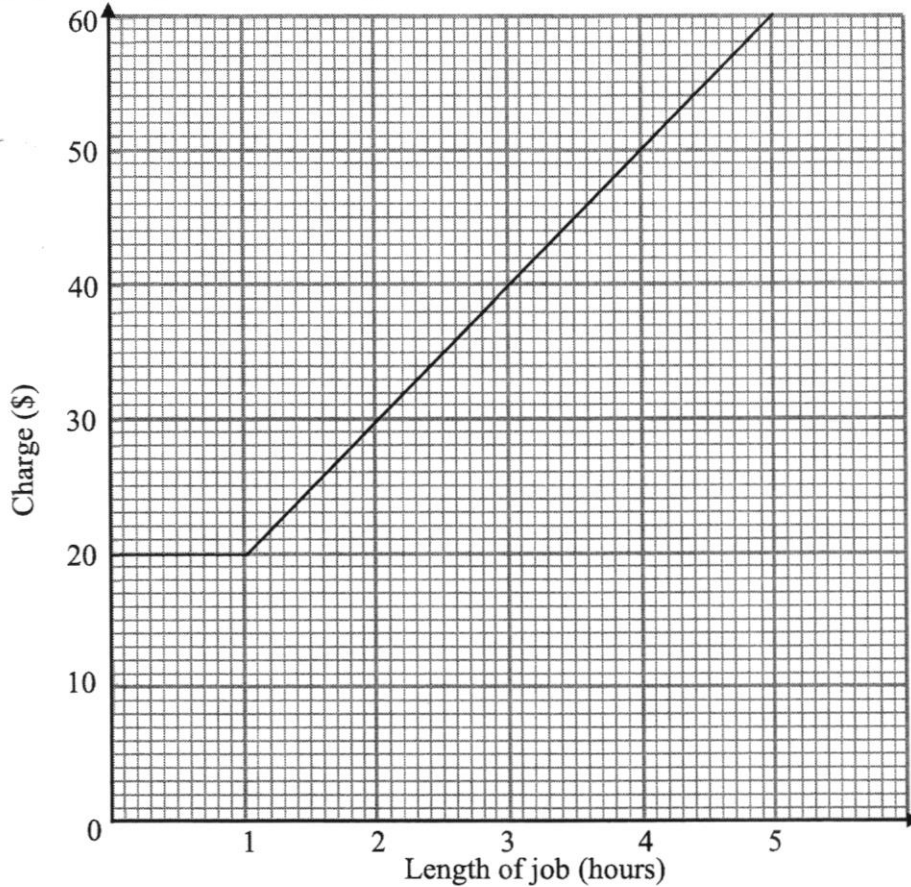

- (a) (i) What is the basic fee charged by plumber A?  
 Answer \$ ..... [1]
- (ii) How much does plumber A charge for 3 hours of work?  
 Answer \$ ..... [1]
- (b) Plumber B charges a fixed rate of \$15 per hour.  
 (i) Complete the table. [2]

Length of job (hours)	0	3	4
Charge (\$)	0		

- (ii) Plot the 3 points on the same axes above and draw a line to show plumber B's charges. [2]
- (c) What is the length of job if both plumber A and plumber B charge the same?  
 Answer ..... hours [1]



## WOODLANDS RING SECONDARY SCHOOL

---

Name : \_\_\_\_\_ Reg No. \_\_\_\_\_ Class : 2T7

---

**EXAMINATION : END-OF-YEAR EXAMINATION**

**LEVEL : SECONDARY 2 NORMAL TECHNICAL DATE: 04 Oct 2018**

**SUBJECT : MATHEMATICS PAPER: 2**

**DURATION : 1 hour 15 minutes MAX MARKS: 50**

**SETTER(S) : Mrs Sharon Sim Parent's/Guardian's Signature:**

---

### INSTRUCTIONS TO CANDIDATES

Write your name, class and register number on all the work you hand in.

Write in dark blue or black pen in the spaces provided on the Question Paper.

You may use a pencil for any diagrams or graphs.

Do not use staples, paper clips, glue or correction fluid.

Answer **all** questions.

The number of marks is given in brackets [ ] at the end of each question or part question.

If working is needed for any question, it must be shown in the space below the question.

Omission of essential working will result in loss of marks.

The use of an approved scientific calculator is expected, where appropriate.

If the degree of accuracy is not specified in the question, and if the answer is not exact, give the answer to three significant figures. Give answers in degrees to one decimal place.

For  $\pi$ , use either your calculator value or 3.142.

For Examiner's Use

/50

***Mathematical Formulae****Compound interest*

$$\text{Total amount} = P \left( 1 + \frac{r}{100} \right)^n$$

Answer **all** the questions.

- 1 Change S\$800 into Malaysian Ringgit (MYR) when the exchange rate is S\$1 = 2.983 MYR.

*Answer* ..... MYR [2]

---

- 2 By rounding each number to 1 significant figure, **estimate** the value of

$$\frac{4.23 \times 58.9}{8.28 - 1.78}$$

You must show your working.

*Answer* ..... [3]

---

- 3 A swimming pool can be filled with water in 12 hours using 4 pumps.

How many hours would it take if 8 pumps were used?

*Answer* ..... [2]

---

- 4 At a school event  $\frac{1}{2}$  of the audience were students,  $\frac{1}{5}$  were staff and the remaining were visitors.  
What fraction were visitors?

*Answer* ..... [1]

---

5 Calculate

(a)  $\sqrt[3]{47}$

Answer ..... [1]

(b)  $7^2 - 4 \times 3 \times (-2)$

Answer ..... [1]

---

6 Solve the following equations.

(a)  $2x + 7x = 63$

Answer  $x =$  ..... [2]

(b)  $9y = 5y - 15$

Answer  $y =$  ..... [2]

(c)  $3(2z + 5) = 12$

Answer  $z =$  ..... [3]

---

5

7 (a)

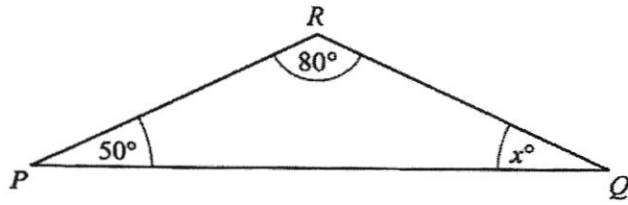

Find  $x$ .

Answer  $x = \dots\dots\dots$  [1]

(b)

Find angle  $y$ .

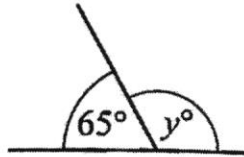

Answer  $y = \dots\dots\dots$  [1]

8

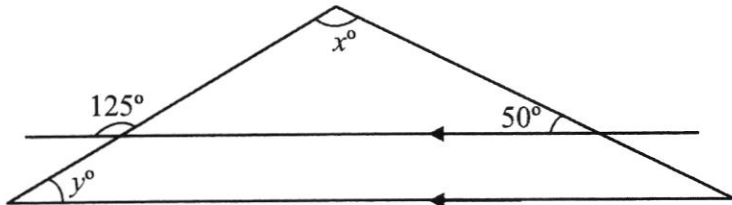

(a) Find angle  $x$ .

Answer  $x = \dots\dots\dots$  [2]

(b) Find angle  $y$ .

Answer  $y = \dots\dots\dots$  [1]

9

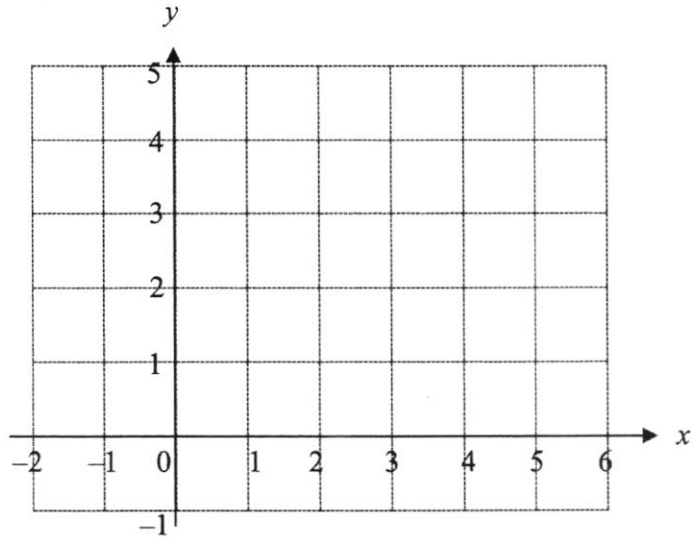

- (a) Plot and label the points  $A(-1, 2)$  and  $B(3, 4)$  [2]
- (b) Find the gradient of the line  $AB$ .

Answer ..... [2]

10 Find the unknown sides of the following right angle triangles.

(a)

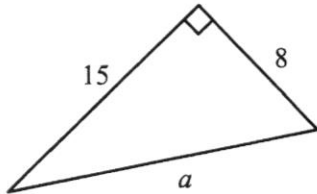

Answer  $a =$  ..... [2]

(b)

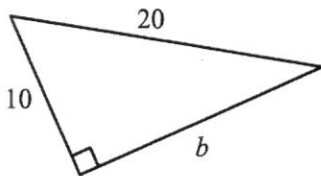

Answer  $b =$  ..... [2]

11

<p><u>Krunchybits</u></p> <p>Contains</p> <p>7.8% fruit</p>	<p><u>Yummybran</u></p> <p>4 g of fruit</p> <p>in every</p> <p>70 g portion</p>
---	---

Which cereal contains more fruit in a 70g portion and by how much?





Answer ..... contains more fruit by ..... g. [3]

12 Asraf and Ifah are doing a survey on how people travel to work.

- (a) Asraf got his data by asking people outside the MRT station.  
Explain why this is not a good way to obtain his data.

Answer ..... [1]

- (b) Ifah illustrates her results in a pictogram.  
She has drawn the pictogram for bus, MRT, walking and car.

Method of travel		Key
Bus		 represents 10 people
MRT		
Walking		
Car		

- (i) How many people travelled by MRT?

Answer ..... [1]

- (ii) How many people walked?

Answer ..... [1]

- 13 The following data represents the number of waffles eaten by students in one week.

2	4	3	3	1	0	0	1	2	2
4	5	3	2	2	1	1	0	0	2

- (a) Complete the frequency table for the data. [2]

Number of waffles	0	1	2	3	4	5
Number of students (Frequency)						

- (b) Represent the data in a dot diagram. [2]

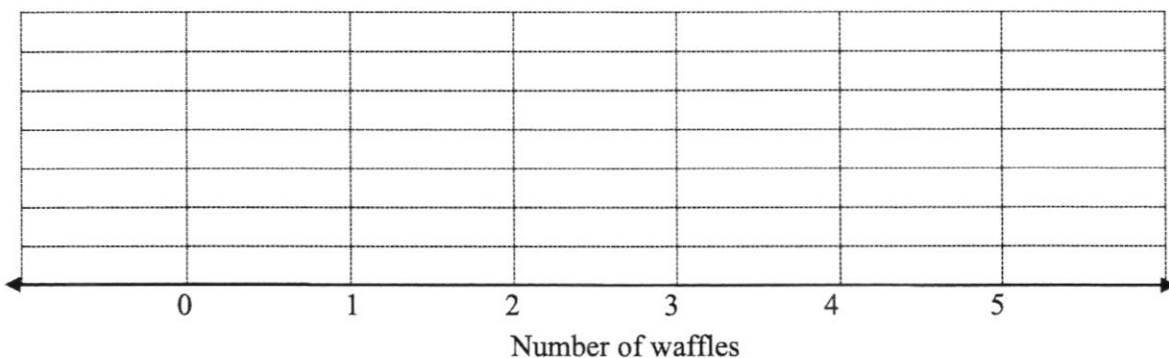

- (c) How many students were surveyed?

*Answer* ..... students [1]

- (d) How many students ate more than 2 waffles in one week?

*Answer* ..... students [1]

- (e) What is the mode?

*Answer* ..... waffles [1]

- (f) Calculate the percentage of students who ate more than 2 waffles in one week.

*Answer* ..... [1]

14 Sally and Johnny each had \$3000 to invest for 3 years.

(a) Sally invested her \$3000 in an account which paid **simple interest** at a rate of 2.5% per annum. Calculate

(i) the interest she earned at the end of 3 years,

*Answer* \$..... [1]

(ii) the total amount she has in her account at the end of 3 years.

*Answer* \$..... [1]

(b) Johnny invested his \$3000 in an account which paid **compound interest** at a rate of 2.3% per annum.

Who received more interest at the end of 3 years and by how much?

Give your answer to the nearest cent.

*Answer* ..... received \$..... more interest. [4]

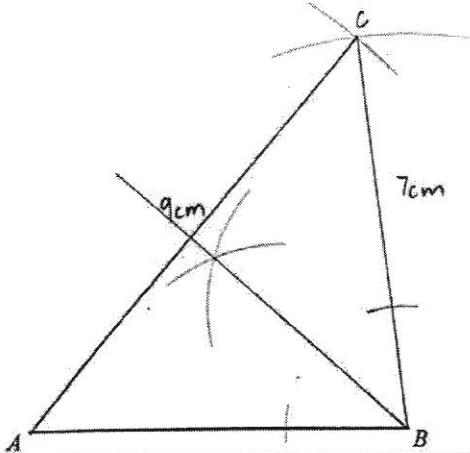
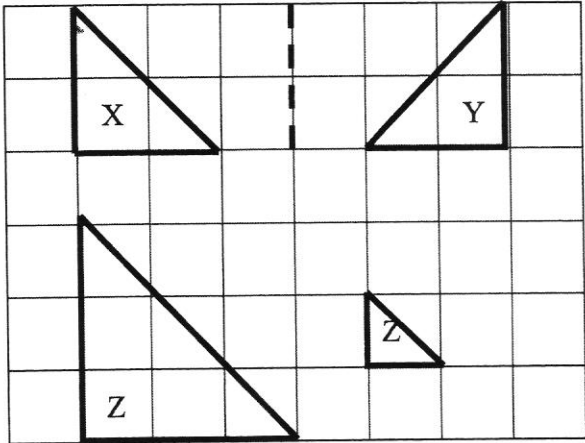
Qn	Working	Marks
1	(a) 7.98 (3 s.f.)	B1
	(b) 8.0 (1 d.p.)	B1
2	$\frac{8}{13}$ 0.60    59%    0.43	B2 B1 for 2 consecutive correct order
3	(a) 3 : 7	B1
	(b) (i) 10 units $\rightarrow$ 40 hours 1 unit $\rightarrow$ 4 hours 3 units $\rightarrow$ $4 \times 3$ = 12 hours	M1  A1
	(ii) 40 - 12 = 28 hours	B1
4	(a) Speed = $\frac{1650}{15}$ = 110 m/min	A1
	(b) Speed = $1.65\text{km} \div \frac{15}{60}\text{h}$ = 6.6 km/h	M1 (conversion of units) A1
5	<p><i>Answer</i></p> 	(a) Accuracy – M1 Construction lines – M1  (b) Correct construction of angle bisector at angle ABC – A1
6		(a) A1: Y is drawn correctly  (b) A1: Either enlargement or reduction

7	(a) $8x + 3$	B1
	(b) $4x + 12$	B1
	(c) $2x + \frac{1}{2}x - \frac{2}{3}x = \frac{12}{6}x + \frac{3}{6}x - \frac{4}{6}x$ $= \frac{11}{6}x$	M1  A1
8	$\sqrt{0.25(3 + 6)} = \frac{3}{2}$	M1 show substitution A1
9	(a) $5.3 \div 500$ $= 0.0106 \text{ cm}$	M1 A1
	(b) Volume = $29.7 \times 21 \times 5.3$ $= 3305.61 \text{ cm}^3$	M1 A1
10	(a) $80 \times 85\%$ $= \$68$	M1 A1
	(b) $\frac{10}{80} \times 100\%$ $= 12.5\%$	M1 A1
11	(a) $\angle QRP$	B1
	(b) $\frac{4}{10} = \frac{2}{5}$	B1
	(c) (i) $\frac{6}{x} = \frac{2}{5}$ $2x = 30$ $x = 15$	M1  A1
	(ii) $\frac{y}{20} = \frac{2}{5}$ $5y = 40$ $y = 8$	M1  A1
	(d) Perimeter = $20 + 10 + 15$ $= 45 \text{ cm}$	A1
12	(a) $BC^2 = 8^2 + 15^2$ $= 289$ $BC = \sqrt{289}$ $= 17 \text{ cm}$	M1   A1
	(b) Perimeter = $17 + 17 + 17 + 8 + 15$ $= 74 \text{ cm}$	B1
	(c) Area of square = $17 \times 17$ $= 289 \text{ cm}^2$ Area of triangle = $\frac{1}{2} \times 8 \times 15$ $= 60 \text{ cm}^2$ Area of pentagon = $289 + 60$ $= 349 \text{ cm}^2$	M1  M1  A1

13	(a) (i) \$20		B1							
	(ii) \$40		B1							
	(b) (i)		Each correct answer: B1							
	<table border="1" style="width: 100%; border-collapse: collapse; text-align: center;"> <tr> <td style="padding: 5px;">Length of job (hours)</td> <td style="padding: 5px;">0</td> <td style="padding: 5px;">3</td> <td style="padding: 5px;">4</td> </tr> <tr> <td style="padding: 5px;">Charge (\$)</td> <td style="padding: 5px;">0</td> <td style="padding: 5px;"><u>45</u></td> <td style="padding: 5px;"><u>60</u></td> </tr> </table>	Length of job (hours)	0	3	4	Charge (\$)	0	<u>45</u>	<u>60</u>	
Length of job (hours)	0	3	4							
Charge (\$)	0	<u>45</u>	<u>60</u>							
(ii)	<p>The graph shows two lines representing charging rates. The y-axis is labeled 'Charge (\$)' and ranges from 0 to 60 in increments of 10. The x-axis is labeled 'Length of job (hours)' and ranges from 0 to 5 in increments of 1. One line is a straight line starting at (0,0) and ending at (5,60). The other line starts at (0,0), passes through (1,20), (3,45), and ends at (4,60). The points (3,45) and (4,60) are marked with an 'x'.</p>		M1: 3 points plotted correctly M1: 3 points joined by a straight line							
	(c) 2 hours		B1							

Qn	Working	Marks
1	$2.983 \times 800$ $= 2386.40 \text{ MYR}$	M1 A1
2	$\frac{4.23 \times 58.9}{8.28 - 1.78} \approx \frac{4 \times 60}{8 - 2}$ $= \frac{240}{6}$ $= 40$	M2 (rounding to 1 sf) – M1 for any 1 mistake A1
3	4 pumps $\rightarrow$ 12 hours 1 pump $\rightarrow 12 \times 4$ $= 48 \text{ hours}$ 8 pumps $\rightarrow 48 \div 8$ $= 6 \text{ hours}$	M1  A1
4	Visitors $= 1 - \frac{1}{2} - \frac{1}{5}$ $= \frac{3}{10}$	B1
5	(a) 3.61 (3 sf)	B1
	(b) 73	B1
6	(a) $2x + 7x = 63$ $9x = 63$ $x = 7$	M1 A1
	(b) $9y = 5y - 15$ $9y - 5y = -15$ $4y = -15$ $y = -3.75 \text{ or } -3\frac{3}{4}$	M1 A1
	(c) $3(2z + 5) = 12$ $6z + 15 = 12$ $6z = -3$ $z = -0.5 \text{ or } -\frac{1}{2}$	M1 M1 A1
7	(a) $x = 180 - 80 - 50$ $= 50$	A1
	(b) $y = 180 - 65$ $= 115$	A1
8	(a) other base angle of triangle $= 180 - 125$ $= 55$  $x = 180 - 55 - 50$ $= 75$	M1  A1
	(b) $y = 55$ (alternate angles)	A1

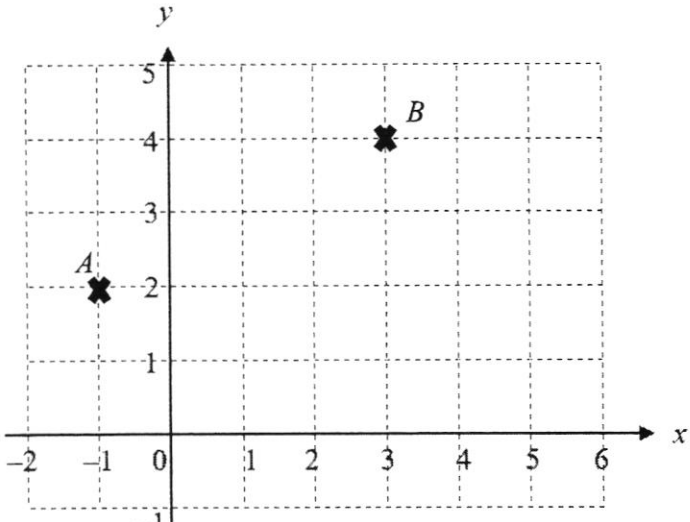
<p>9</p>	<p>(a)</p> 	<p>M1 for each correctly marked and labelled point</p>
	<p>(b) Gradient = <math>\frac{2}{4}</math> = <math>\frac{1}{2}</math> or 0.5</p>	<p>M1 correct vertical and horizontal change A1</p>
<p>10</p>	<p>(a) <math>a^2 = 15^2 + 8^2</math> = 289 <math>a = \sqrt{289}</math> = 17</p>	<p>M1  A1</p>
	<p>(b) <math>20^2 = 10^2 + b^2</math> <math>b^2 = 20^2 - 10^2</math> = 300 <math>b = \sqrt{300}</math> = 17.3 (3 sf)</p>	<p>M1  A1</p>
<p>11</p>	<p><i>Krunchybits</i> = <math>70 \text{ g} \times 7.8\%</math> = 5.46 g <i>Yummybran</i> = 4 g Difference = <math>5.46 - 4</math> = 1.46 g <b><u>Krunchybits</u></b> contains more fruit by <b><u>1.46 g</u></b>.</p>	<p>M1  M1  A1</p>
<p>12</p>	<p>(a) Most of the people he ask will take MRT instead of other transport. Or The data he obtained will not be accurate.</p>	<p>B1</p>
	<p>(b) (i) 45 people</p>	<p>B1</p>
	<p>(ii) 20 people</p>	<p>B1</p>

13	(a)	<table border="1"> <tr> <td>Number of waffles</td> <td>0</td> <td>1</td> <td>2</td> <td>3</td> <td>4</td> <td>5</td> </tr> <tr> <td>Number of students (Frequency)</td> <td><u>4</u></td> <td><u>4</u></td> <td><u>6</u></td> <td><u>3</u></td> <td><u>2</u></td> <td><u>1</u></td> </tr> </table>	Number of waffles	0	1	2	3	4	5	Number of students (Frequency)	<u>4</u>	<u>4</u>	<u>6</u>	<u>3</u>	<u>2</u>	<u>1</u>	B2 -1 for an incorrect answer
	Number of waffles	0	1	2	3	4	5										
	Number of students (Frequency)	<u>4</u>	<u>4</u>	<u>6</u>	<u>3</u>	<u>2</u>	<u>1</u>										
	(b)		B2 -1 for an incorrect answer														
	(c)	20 students	B1														
	(d)	6 students	B1														
(e)	2 waffles	B1															
(f)	$\frac{6}{20} \times 100\% = 30\%$	A1															
14	(a) (i)	$\text{Interest} = 3000 \times 2.5\% \times 3$ $= \$225$	A1														
	(ii)	$\text{Total amount} = \$3000 + \$225$ $= \$3225$	A1														
	(b)	$\text{Johnny total amount} = 3000 \left(1 + \frac{2.3}{100}\right)^3$ $= \$3211.80 \text{ (nearest cent)}$	M1														
		$\text{Johnny interest} = \$3211.80 - \$3000$ $= \$211.80$	M1														
		$\text{Difference} = \$225 - \$211.80$ $= \$13.20$	M1														
	<b>Sally</b> received <b>\$13.20</b> more interest.	A1															