

Visit

FREETESTPAPER.com

for more papers



Website: [freetestpaper.com](http://www.freetestpaper.com)



[Facebook.com/freetestpaper](https://www.facebook.com/freetestpaper)



[Twitter.com/freetestpaper](https://www.twitter.com/freetestpaper)



East Spring Secondary School
Towards Excellence and Success

Name: _____ ()

Class: Sec 3-____

First Semester Examinations 2018
Secondary 3 Express

Mathematics

Paper 1

Monday 7 May 2018

2 hours
0800 – 1000

INSTRUCTIONS TO CANDIDATES

Write your name, class and register number in the spaces provided on the paper/ answer booklet.

Write in dark blue or black pen on both sides of the paper.
Do not use staples, paper clips, highlighters, glue or correction fluid.

Answer **All** questions.

Write your answers in the space provided on the question booklet.
If working is needed for any question it must be shown with the answer.

Omission of essential working will result in loss of marks.

Calculators should be used where appropriate.

If the degree of accuracy is not specified in the question and if the answer is not exact, the answer should be given to three significant figures. Answers in degrees should be given to one decimal place.

For π , use either your calculator value or 3.142 unless the question requires the answer in terms of π .

You are reminded of the need for good English and clear presentation in your answers. At the end of the examination, fasten all your work securely together.

INFORMATION FOR CANDIDATES

The number of mark is given in brackets [] at the end of each question or part question.

The total number of marks for this paper is **80**.

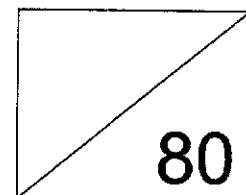

This question paper consists of **16** printed pages including the cover page.



Mathematical Formulae

Compound Interest

$$\text{Total amount} = P \left(1 + \frac{r}{100} \right)^n$$

Mensuration

$$\text{Curve surface area of a cone} = \pi r l$$

$$\text{Surface area of a sphere} = 4\pi r^2$$

$$\text{Volume of a cone} = \frac{1}{3} \pi r^2 h$$

$$\text{Volume of a sphere} = \frac{4}{3} \pi r^3$$

$$\text{Area of triangle ABC} = \frac{1}{2} ab \sin C$$

$$\text{Arc length} = r\theta, \text{ where } \theta \text{ is in radians}$$

$$\text{Area of sector} = \frac{1}{2} r^2 \theta \text{ where } \theta \text{ is in radians}$$

Trigonometry

$$\frac{a}{\sin A} = \frac{b}{\sin B} = \frac{c}{\sin C}$$

$$a^2 = b^2 + c^2 - 2bc \cos A$$

Statistics

$$\text{Mean} = \frac{\sum fx}{\sum f}$$

$$\text{Standard deviation} = \sqrt{\frac{\sum fx^2}{\sum f} - \left(\frac{\sum fx}{\sum f} \right)^2}$$



Answer all the questions

1. (a) Evaluate $\frac{\sqrt{7.21+(2.45 \times 7)^2}}{9-\sqrt{29}}$, giving your answer correct to 4 significant figures.
- (b) Express $23\frac{1}{4}\%$ as a decimal.

Ans: (a) _____ [1]

(b) _____ [1]

2. The numerator of a fraction is 2 less than the denominator. If 3 is subtracted from the numerator and 7 is added to the denominator, the fraction becomes $\frac{1}{5}$. Find the original fraction.

Ans: _____ [2]



3. 180 can be expressed as a product of its prime factors as $2^2 \times 3^2 \times 5$.
- (a) (i) Express 240 as a product of its prime factors.
- (ii) Hence, find the HCF of 180 and 240.
- (b) Given that $3780 = 2^2 \times 3^3 \times 5 \times 7$, find the smallest integer x such that the lowest common multiple of 14, 180 and x is 3780.

Ans: (a) (i) _____ [2]
 (ii) _____ [1]
 (b) _____ [1]

4. In a class of 40 students, $\frac{3}{5}$ are girls and the remaining students are boys.
- $\frac{5}{8}$ of the girls are short-sighted and $\frac{3}{4}$ of the boys are short-sighted.
- (a) If a student is selected at random, find the probability that the student will be a short-sighted boy.
- (b) If a short-sighted student is selected at random, find the probability that the student will be a girl.

Ans: (a) _____ [2]
 (b) _____ [2]



5. In the diagram, PQ , LM and RS are parallel. $PQ = 30$ cm and $RS = 50$ cm. M lies on both PS and QR .

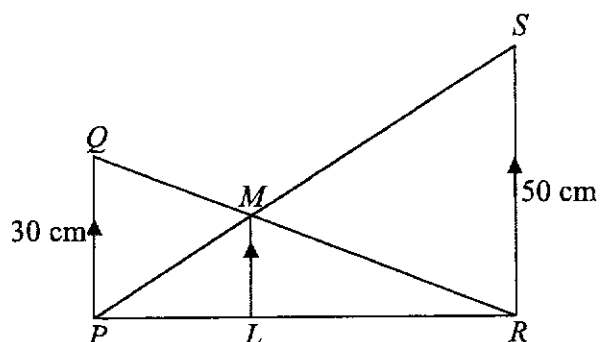

- (a) Is $\triangle QPM$ similar to $\triangle RSM$? Explain your answer with working.
 (b) Find the ratio of $PM : SM$.
 (c) Find the length of ML .

Ans: (a) _____ [2]

(b) _____ [1]

(c) _____ cm [2]



6. A ladder AB leans against a vertical wall OT . $OA = 4.8$ m and $OB = 3.6$ m. If the ladder slid down to a new position CD and $OC = 2.5$ m, find

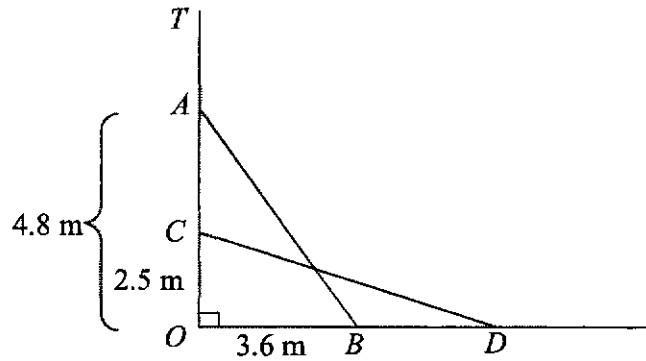

- (a) the length of the ladder AB .
 (b) the distance BD .

Ans: (a) _____ m [2]
 (b) _____ m [2]



7. In the diagram, $AB = 20$ cm, $BD = 24$ cm and ABC is a straight line and $\angle BAD = 90^\circ$.

- (a) Find the value of x .
(b) Given that $BC = 8$ cm, find $\angle ADC$.

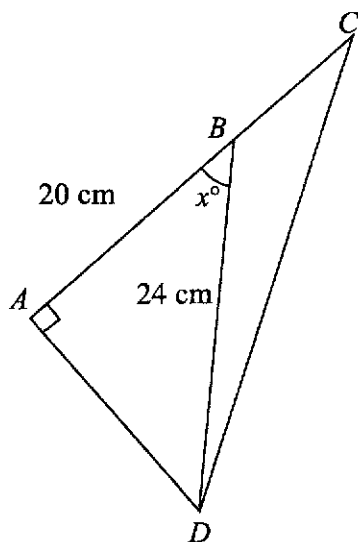

- Ans: (a) $x =$ _____ [2]
(b) $\angle ADC =$ _____ $^\circ$ [2]

8. (a) Expand and simplify $x^2 - (x - a)(x + a)$.
(b) Hence, by showing your workings clearly, evaluate $32185^2 - 32181 \times 32189$.

- Ans: (a) _____ [2]
(b) _____ [1]



9. Simplify each of the following.

(a) $\frac{9x-18}{2x^2-4x}$

(b) $\frac{x^2-5x-14}{3x+6} \div \frac{(x-7)^2}{5}$

Ans: (a) _____ [2]
(b) _____ [3]



10. It is given that y is inversely proportional to $(x^2 - 3)$ and $x = 3$ when $y = 1$.

- (a) Find the equation connecting x and y .
(b) Find the values of x when $y = 4.5$.

Ans: (a) _____ [2]
(b) _____ [2]

11. Given that $-7 \leq \frac{5x+6}{2} < 2x+11$,

- (a) find the range of values of x .
(b) find the smallest possible value of x^2 .

Ans: (a) _____ [3]
(b) _____ [1]



12. The diagram shows part of a regular polygon with n sides. Given that $\angle RST = 140^\circ$

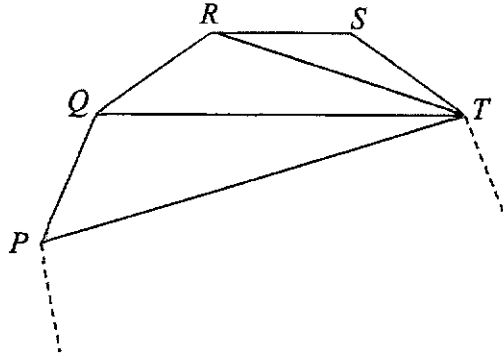

Find

- (a) the value of n .
(b) $\angle QRT$

Ans: (a) $n = \underline{\hspace{2cm}}$ [2]
(b) $\angle QRT = \underline{\hspace{2cm}}^\circ$ [2]



13. A solid metal cone has a volume of $100\pi \text{ cm}^3$ and base radius of 5 cm.

Find

- (a) the height of the cone.
(b) the radius of a hemisphere, if the entire cone is melted and made to form a hemisphere.

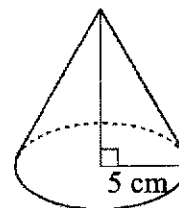

Ans: (a) _____ cm [2]
(b) _____ cm [2]



14. Thomas deposited \$15000 into each of the 2 banks, bank A and B , for 5 years. Both banks pay the same interest rate of 1.5% per annum. Find the total amount of money he would collect from
- (a) bank A if it pays simple interest.
 - (b) bank B if it pays compound interest half-yearly.

Ans: (a) \$ _____ [2]
(b) \$ _____ [2]



15. In the diagram, O is the centre of the circle. CBD is a straight line, $\angle OBA = 40^\circ$ and $\angle BAC = 69^\circ$.

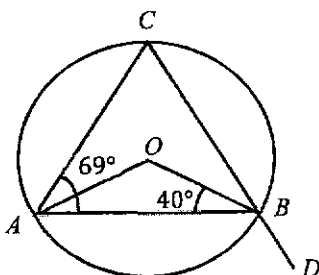

Calculate

- (a) $\angle ACB$
(b) $\angle ABD$

Ans: (a) $\angle ACB = \underline{\hspace{2cm}}^\circ$ [2]
(b) $\angle ABD = \underline{\hspace{2cm}}^\circ$ [2]

16. The table shows a survey done on 30 pupils to find out the amount of time they spent surfing the internet during weekends.

No. of hours	0	1	3	5
No. of pupils	2	13	8	7

Find

- (a) the mean number of hours.
(b) the median number of hours.

Ans: (a) $\underline{\hspace{2cm}}$ [2]
(b) $\underline{\hspace{2cm}}$ [1]



17. (a) Express $x^2 - 6x - 2$ in the form $(x - a)^2 + b$.
 (b) Hence, solve $x^2 - 6x - 2 = 5$.

Ans: (a) _____ [2]

(b) _____ [2]

18. (a) Sketch the graph of $y = (x + 1)(x - 2)$. [3]

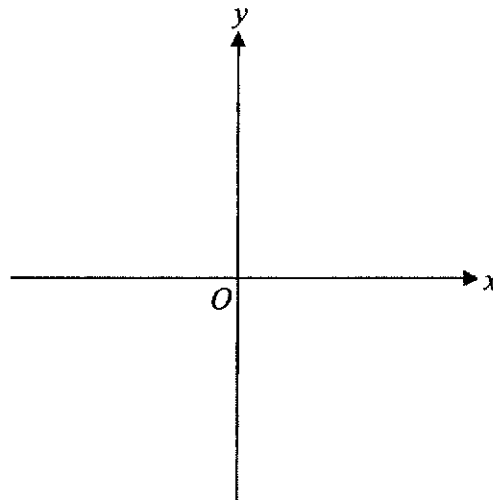

- (b) State the equation of the line of symmetry of the graph $y = (x + 1)(x - 2)$.

Ans: (b) _____ [2]



19. Given that $T = 2h\sqrt{\frac{L}{g}}$,

- (a) express L in terms of h , g and T .
 (b) find the value of T when $h = 3$, $L = 4$ and $g = 9$.

Ans: (a) $L =$ _____ [2]

(b) _____ [2]

20. A map is drawn to a scale of 1 : 20000. A cyclist travelled from Town A to Town B which are 10.4 km apart.



- (a) Calculate, in cm, the distance between the two towns on the map.
 (b) The cyclist visited a carnival in Town B . The area of the carnival on the map is 6.7 cm^2 . Calculate, in km^2 , the actual area of the carnival.

Ans: (a) _____ cm [2]

(b) _____ km^2 [2]



21. The pictogram below shows the number of commuters at Airport Z yearly.

<u>Year</u>	<u>Number of Commuters</u>	
2014		400 Thousand
2015		500 Thousand
2016		1 Million

- (a) The number of commuters increased by 100% from 2012 to 2013 and then decreased by 20% in 2014. Find the number of commuters in 2012.
- (b) State **one** aspect of the pictogram as displayed above that may be misleading and explain how this may lead to a misinterpretation of the actual data.

Ans: (a) _____ [2]

(b) _____ [1]

--- End of Paper ---



East Spring Secondary School
Towards Excellence and Success

Name: _____ ()

Class: _____

First Semester Examination 2018
Secondary 3 Express

Mathematics
Paper 2

4048/02

2 May 2018
Wednesday

2 h 30 min
1005 - 1235

Additional materials:

6 sheets of writing paper

1 sheet of graph paper

1 sheet of blank paper

INSTRUCTIONS TO CANDIDATES

Write your name, class and register number in the spaces provided on the writing paper.

Write in dark blue or black pen on both sides of the paper.
Do not use staples, paper clips, highlighters, glue or correction fluid.

Answer **all** questions.

Write your answers on the separate writing papers provided.

If working is needed for any question it must be shown with the answer.

Omission of essential working will result in loss of marks.

Electronic calculators can be used in this paper.

If the degree of accuracy is not specified in the question, and if the answer is not exact, give the answer to three significant figures. Give answers in degrees to one decimal place.

For π , use either your calculator value or 3.142, unless the question requires the answer in terms of π .

You are reminded of the need for good English and clear presentation in your answers. At the end of the examination, fasten all your work securely together.

INFORMATION FOR CANDIDATES

The number of marks is given in brackets [] at the end of each question or part question.

The total number of marks for this paper is 100.

MARKS:

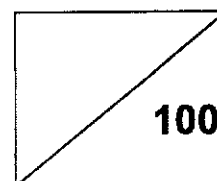

This question paper consists of **8** printed pages including the cover page.



Mathematical Formulae

Compound interest

$$\text{Total amount} = P \left(1 + \frac{r}{100} \right)^n$$

Mensuration

$$\text{Curved surface area of a cone} = \pi r l$$

$$\text{Surface area of a sphere} = 4\pi r^2$$

$$\text{Volume of a cone} = \frac{1}{3}\pi r^2 h$$

$$\text{Volume of a sphere} = \frac{4}{3}\pi r^3$$

$$\text{Area of triangle } ABC = \frac{1}{2} ab \sin C$$

$$\text{Arc length} = r\theta, \text{ where } \theta \text{ is in radians}$$

$$\text{Sector area} = \frac{1}{2}r^2\theta, \text{ where } \theta \text{ is in radians}$$

Trigonometry

$$\frac{a}{\sin A} = \frac{b}{\sin B} = \frac{c}{\sin C}$$

$$a^2 = b^2 + c^2 - 2bc \cos A$$

Statistics

$$\text{Mean} = \frac{\sum fx}{\sum f}$$

$$\text{Standard deviation} = \sqrt{\frac{\sum fx^2}{\sum f} - \left(\frac{\sum fx}{\sum f} \right)^2}$$



ANSWER ALL QUESTIONS

- 1 (a) Factorise completely $5x^2 - 20$. [1]
- (b) Simplify $\frac{5x^2 - 20}{x^2 - x - 2}$. [2]
- (c) Express $\frac{3}{y+5} - \frac{4}{y-3}$ as a single fraction in its simplest form. [2]
- (d) Given that $x \leq 15\frac{1}{3}$, state the largest value of x if x is
- (i) an integer, [1]
- (ii) a prime number, [1]
- (iii) a rational number. [1]
- (e) There are 20 pieces of \$2 notes and \$10 notes in an envelope. If the total value of all the notes is less than \$120, find the minimum number of \$2 notes in the envelope. Hence, find the total value of all the notes in the envelope. [3]

- 2 Lynn and Sam took part in a marathon race. They each ran a distance of 42 km.
- (a) Lynn ran at a constant speed of x km/h.
Write down an expression, in terms of x , for the number of hours Lynn took. [1]
- (b) Sam ran at a constant speed which was 0.5 km/h slower than Lynn.
Write down an expression, in terms of x , for the number of hours Sam took. [1]
- (c) The difference between their times was 10 minutes. Form an equation and show that it reduces to $2x^2 - x - 252 = 0$. [2]
- (d) Solve the equation $2x^2 - x - 252 = 0$, giving your answers correct to three decimal places. [3]
- (e) Calculate the time that Lynn took to complete the race, giving your answer in hours and minutes. [2]



-
- 3 (a) Simplify
- (i) $\left(\frac{1}{a}\right)^{-2}$, [1]
- (ii) $(2x^0y^4)^3$. [2]
- (b) Solve the equation $8^x = 16$. [2]
- (c) Given that $a^3 \times a^4 \div \sqrt{a} = a^k$, write down the value of k . [3]
-

- 4 (a) Given that $5.44 \times 10^{-22} = k \times 10^{-17}$. Find the value of k in standard form. [1]
- (b) At a certain time, the population of an organism is 74 billion.
- (i) Write 74 billion in standard form. [1]
- (ii) The population doubles every 15 days.
 Find the population 45 days later.
 Write your answer in standard form. [2]
- (c) To make a cake, you mix flour, sugar and butter in the ratio 5 : 3 : 2.
 How many grams of sugar is needed to make a cake weighing 1800 g? [2]
- (d) An airplane travels for $1\frac{3}{4}$ hours at 720 km/h.
 It then travels for 4 hours at 650 km/h.
 Find the average speed for the whole journey. [3]
-

Answer the whole of this question on a single sheet of blank paper provided.

- 5 In triangle ABC , $AB = 7.5$ cm, $AC = 5.5$ cm and $BC = 9$ cm.
- (a) Construct triangle ABC . [3]
- (b) Measure $\angle ACB$. [1]
- (c) Construct the angle bisector of $\angle ABC$. [1]
- (d) Construct the perpendicular bisector of BC . [1]
- (e) The angle bisector of $\angle ABC$ meets the perpendicular bisector of BC at X .
 Measure the length of BX . [1]



- 6 The coordinates of A , B and C are $(-2, 4)$, $(-2, 8)$ and $(6, -4)$ respectively.

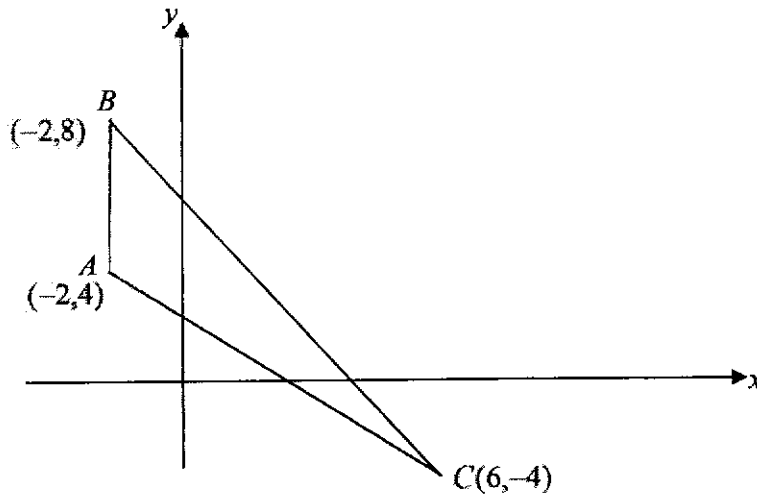

- (a) Find the gradient of the line BC . [1]
- (b) Find the length of BC . [2]
- (c) Find the area of $\triangle ABC$. [2]
- (d) Find the shortest distance from A to the line BC . [2]
- (e) Find the equation of the line through A and is parallel to BC . [2]

- 7 A semi-circular prism of radius r cm is fitted exactly on top of a trapezoidal prism to form a solid as shown. The shaded region has an area of 184 cm^2 .

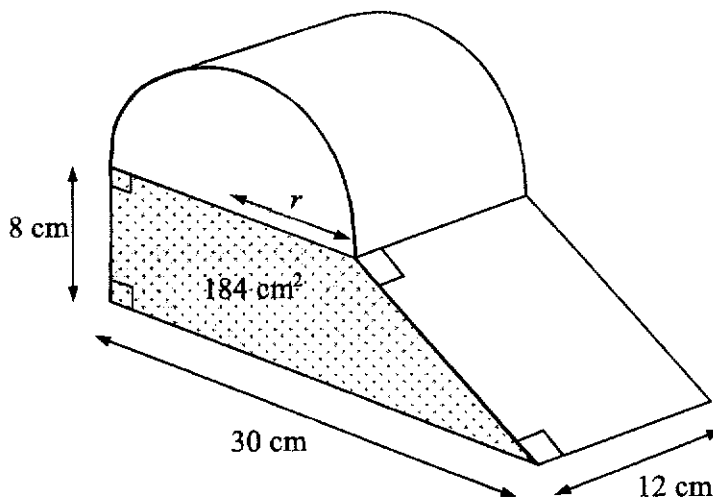

- (a) Show that $r = 8$ cm. [2]
- (b) Find the total volume of the solid. [3]
- (c) The entire exterior surface area of the solid is to be painted. The cost of paint is $\$0.02$ per cm^2 . Find the total cost of paint. [5]



8 The first three terms in a sequence of numbers, are given below.

$$T_1 = 1^3 + 3 = 4$$

$$T_2 = 2^3 + 6 = 14$$

$$T_3 = 3^3 + 9 = 36$$

(a) (i) Find T_4 . [1]

(ii) Find an expression, in terms of n , for T_n . [2]

(iii) Evaluate T_{60} . [1]

(b) The first four terms in a different sequence are 5, 9, 13, 17.

Find an expression, in terms of n , for the n th term, P_n , of this sequence. [1]

(c) By forming an equation in n , find the values of n for which $\frac{T_n}{P_n} = \frac{n^2}{4}$. [3]

9 The diagram shows the speed - time graph of a train.

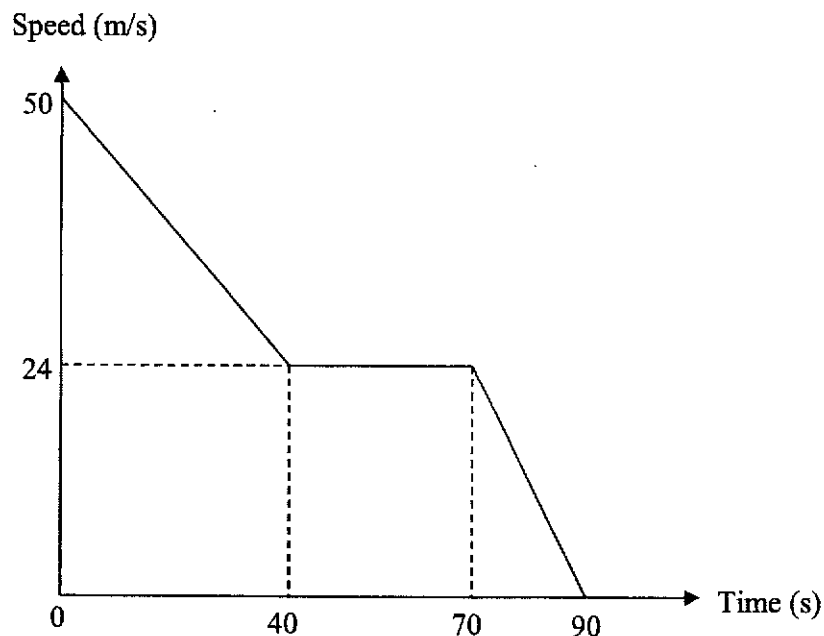

Calculate the

(a) deceleration during the first 40 seconds. [2]

(b) speed of the train at 30 seconds. [2]

(c) total distance travelled. [3]

(d) average speed of the whole journey. [2]



10 Answer the whole of this question on a single sheet of graph paper.

The variables x and y are related by the equation $y = 24 + 3x - 2x^2$.

x	-3	-2	-1	0	1	2	3	4	5
y	-3	10	p	24	25	q	15	4	-11

- (i) Find the value of p and q . [2]
- (ii) Use a scale of 2 cm to 1 unit on the horizontal x -axis and 2 cm to 5 units on the vertical y -axis. Draw the graph of $y = 24 + 3x - 2x^2$. [3]
- (iii) Draw and label the equation of the line of symmetry on the graph. [2]
- (iv) From the graph, find the values of x when $24 + 3x - 2x^2 = 0$. [2]



Real World Context Question

11 The price board displayed at a petrol station on 12 March 2018.

Grade	Pump price (per litre)	Nett price (per litre)
Unleaded 95	\$2.09	x
Unleaded 98	\$2.40	\$2.28
V Power	\$2.65	y

*Pump price refers to the price before a discount is given, whereas nett price refers to the price after a discount is given.

- (a) (i) Show that the ratio of the nett price to the pump price of Unleaded 98 was 19:20. [1]
- (ii) Using the same ratio in (a)(i), find the values of x and y . [2]
- (b) Here are some information about the new parallel imported car Tena Bolt E.V from the United States of America. According to the manufacturer, it is a fuel efficient car suitable for urban city driving.



- Fuel tank capacity: 45 litres
- Fuel consumption: 58.8 miles per gallon (mpg)

Fuel consumption is the distance travelled per unit volume of fuel used. According to the manufacturers, the car can travel 1 mpg. (1 mpg \approx 0.354006km/ litre)

Ronnie drove the car for a distance of 562km with a full tank of fuel. The tank was left with 40% of the fuel in the end. He claimed that the fuel consumption was indeed 58.8mpg accordingly to the manufacturer.

Was his claim correct? Explain your answer based on calculations. [4]

- (c) Ronnie pumped a full tank of Unleaded 95 for the car. He also claimed that the total discount he got would allow him to travel a further distance of approximately 47km. Using your answer in (b), check if Ronnie's claim was correct. [4]

~ END OF PAPER ~



Answer Scheme for E Maths Paper 1

Qn	Workings	Total Marks														
1(a)	4.802	B1														
1(b)	0.2325	B1														
2	$\frac{x-3}{x+2+7} = \frac{1}{5}$ $\frac{x-3}{x+9} = \frac{1}{5}$ $5(x-3) = x+9$ $5x-15 = x+9$ $5x-x = 9+15$ $4x = 24$ $x = 6$ Ans: $\frac{6}{8} = \frac{3}{4}$ (Accept either answer)	M1 A1														
3(a)(i)	<table style="margin-left: auto; margin-right: auto; border-collapse: collapse;"> <tr><td style="border-right: 1px solid black; padding: 2px 10px;">2</td><td style="padding: 2px 10px;">240</td></tr> <tr><td style="border-right: 1px solid black; padding: 2px 10px;">2</td><td style="padding: 2px 10px;">120</td></tr> <tr><td style="border-right: 1px solid black; padding: 2px 10px;">2</td><td style="padding: 2px 10px;">60</td></tr> <tr><td style="border-right: 1px solid black; padding: 2px 10px;">2</td><td style="padding: 2px 10px;">30</td></tr> <tr><td style="border-right: 1px solid black; padding: 2px 10px;">3</td><td style="padding: 2px 10px;">15</td></tr> <tr><td style="border-right: 1px solid black; padding: 2px 10px;">5</td><td style="padding: 2px 10px;">5</td></tr> <tr><td style="border-right: 1px solid black; padding: 2px 10px;">1</td><td style="padding: 2px 10px;"></td></tr> </table> $240 = 2^4 \times 3 \times 5$	2	240	2	120	2	60	2	30	3	15	5	5	1		M1 A1
2	240															
2	120															
2	60															
2	30															
3	15															
5	5															
1																
3(a)(ii)	$180 = 2^2 \times 3^2 \times 5$ $240 = 2^4 \times 3 \times 5$ $HCF = 2^2 \times 3 \times 5 = 60$	B1														
3(b)	$14 = 2 \times 7$ $180 = 2^2 \times 3^2 \times 5$ $x = 3^3$ $LCM = 2^2 \times 3^3 \times 5 \times 7$ Ans: $x = 27$	B1														



4(a)	Number of boys $= \frac{2}{5} \times 40$ $= 16$ Number of short-sighted boys $= \frac{3}{4} \times 16$ $= 12$ P(short-sighted boy) $= \frac{12}{40}$ $= \frac{3}{10}$	M1 A1
4(b)	Number of girls $= \frac{3}{5} \times 40$ $= 24$ Number of short-sighted girls $= \frac{5}{8} \times 24$ $= 15$ P(short-sighted student is a girl) $= \frac{15}{15+12}$ $= \frac{5}{9}$	M1 A1
5(a)	$\angle QMP = \angle RMS$ (vert. opp. \angle) $\angle PQM = \angle SRM$ (alt. \angle , $PQ \parallel RS$) $\angle MPQ = \angle MSR$ (alt. \angle , $PQ \parallel RS$) Yes, since all corresponding angles are equal, then $\triangle QPM$ is similar to $\triangle RSM$.	M1 A1
5(b)	$PM : SM$ $30 : 50$ $3 : 5$	B1
5(c)	$\frac{3}{8} = \frac{ML}{50}$ $ML = \frac{150}{8}$ $ML = 18\frac{3}{4}$ or 18.75	M1 A1



6(a)	Length of ladder $=\sqrt{4.8^2 + 3.6^2}$ $= 6 \text{ m}$	M1 A1
6(b)	OD $=\sqrt{6^2 - 2.5^2}$ $\approx 5.45 \text{ (3s.f)}$ BD $= 5.45 - 3.6$ $\approx 1.85 \text{ m (3s.f)}$	M1 A1
7(a)	$x = \cos^{-1}\left(\frac{20}{24}\right)$ $x = 33.557$ $x \approx 33.6^\circ \text{ (3s.f)}$	M1 A1
7(b)	AD $=\sqrt{24^2 - 20^2}$ $= 13.266 \text{ cm}$ $\angle ADC = \tan^{-1}\left(\frac{28}{13.266}\right)$ $\angle ADC \approx 64.6^\circ$	M1 A1
8(a)	$x^2 - (x-a)(x+a)$ $= x^2 - (x^2 - a^2)$ $= x^2 - x^2 + a^2$ $= a^2$	M1 A1
8(b)	$32185^2 - (32185 - 4)(32185 + 4)$ $= 4^2$ $= 16$	B1
9(a)	$\frac{9x-18}{2x^2-4x}$ $= \frac{9(x-2)}{2x(x-2)}$ $= \frac{9}{2x}$	M1 A1



9(b)	$\frac{x^2 - 5x - 14}{3x + 6} \div \frac{(x - 7)^2}{5}$ $= \frac{(x - 7)(x + 2)}{3x + 6} \div \frac{(x - 7)^2}{5}$ $= \frac{(x - 7)(x + 2)}{3(x + 2)} \times \frac{5}{(x - 7)^2}$ $= \frac{5}{3(x - 7)}$	 M1 M1 A1
10(a)	$y = \frac{k}{x^2 - 3}$ <p>When $x = 3$ and $y = 1$,</p> $1 = \frac{k}{3^2 - 3}$ $1 = \frac{k}{3^2 - 3}$ $1 = \frac{k}{6}$ $k = 6$ $y = \frac{6}{x^2 - 3}$	 M1 A1
10(b)	$4.5 = \frac{6}{x^2 - 3}$ $4.5x^2 - 13.5 = 6$ $4.5x^2 = 19.5$ $x = \pm \sqrt{\frac{19.5}{4.5}}$ $x = \pm 2.08$	 M1 A1
11(a)	$-7 \leq \frac{5x + 6}{2} < 2x + 11$ $-7 \leq \frac{5x + 6}{2}$ $-14 \leq 5x + 6$ $-20 \leq 5x$ $-4 \leq x$ $\frac{5x + 6}{2} < 2x + 11$ $5x + 6 < 4x + 22$ $5x - 4x < 22 - 6$	 M1



	$x < 16$ Ans: $-4 \leq x < 16$	M1 A1
11(b)	Ans: 0	B1
12(a)	$ext \angle = 180 - 140$ $ext \angle = 40$ $n = \frac{360}{40} = 9$ Or $\frac{180(n-2)}{n} = 140$ $180n - 360 = 140n$ $180n - 140n = 360$ $40n = 360$ $n = 9$	M1 A1 M1 A1
12(b)	$\angle SRT = \frac{180-140}{2}$ (base \angle of isos Δ) $\angle SRT = 20^\circ$ $\angle QRT = 140 - 20$ $\angle QRT = 120^\circ$	M1 A1
13(a)	$\frac{1}{3} \pi r^2 h = 100\pi$ $\frac{1}{3} (5^2) h = 100$ $h = \frac{100 \times 3}{25}$ $h = 12cm$	M1 A1
13(b)	$\frac{2}{3} \pi r^3 = 100\pi$ $\frac{2}{3} r^3 = 100$ $r^3 = 100 \div \frac{2}{3}$ $r = \sqrt[3]{100 \div \frac{2}{3}}$ $r \approx 5.31cm$ (3s.f)	M1 A1



14(a)	Simple interest for 5 years $= \frac{1.5}{100} \times 15000 \times 5$ $= \$1125$ Total amount he can collect $= 15000 + 1125$ $= \$16125$	M1 A1
14(b)	$A = 15000 \left(1 + \frac{0.75}{100}\right)^{10}$ $A \approx \$16163.74 \text{ (2d.p.)}$	M1 A1
15(a)	$\angle AOB = 180 - 40 - 40$ (base \angle of isos Δ) $\angle AOB = 100^\circ$ $\angle ACB = 100 \div 2$ (\angle at the centre, is $2\angle$ at circumference) $\angle ACB = 50^\circ$	M1 A1
15(b)	$\angle ABC = 180 - 69 - 50$ (\angle sum of Δ) $\angle ABC = 61^\circ$ $\angle ABD = 180 - 61$ (adj \angle s on a str. line) $\angle ABD = 119^\circ$	M1 A1
16(a)	Mean number of hours $= \frac{(0 \times 2) + (1 \times 13) + (3 \times 8) + (5 \times 7)}{30}$ $= \frac{(0 \times 2) + (1 \times 13) + (3 \times 8) + (5 \times 7)}{30}$ $= 2.4$	M1 A1
16(b)	Median number of hours $= \frac{1+3}{2}$ $= 2$	B1
17(a)	$x^2 - 6x - 2$ $= x^2 - 6x + \left(\frac{6}{2}\right)^2 - \left(\frac{6}{2}\right)^2 - 2$ $= (x-3)^2 - 11$	M1 A1
17(b)	$x^2 - 6x - 2 = 5$ $(x-3)^2 - 11 = 5$ $(x-3)^2 = 16$ $x-3 = \pm 4$ $x = \pm 4 + 3$	M1



	$x = 7$ or $x = -1$	A1
18(a)	<p>When $x = 0$,</p> $y = (0+1)(0-2)$ $y = -2$	
	<p>Correct shape – C1 x – intercept – P1 y – intercept – P1</p>	
18(b)	<p>Mid- pt</p> $= \frac{-1+2}{2}$ $= \frac{1}{2}$ <p>Equation of line of symmetry:</p> $x = \frac{1}{2}$	M1
		A1
19(a)	$T = 2h \sqrt{\frac{L}{g}}$ $\frac{T}{2h} = \sqrt{\frac{L}{g}}$ $\left(\frac{T}{2h}\right)^2 = \frac{L}{g}$ $L = g \left(\frac{T}{2h}\right)^2$	M1
		A1
19(b)	$T = 2(3)\sqrt{\frac{4}{9}}$ $T = 4$	M1
		A1



20(a)	<p>1 cm ----- 20 000 cm 1 cm ----- 0.2 km 0.2 km ----- 1 cm 10.4 km ----- $\frac{1}{0.2} \times 10.4$ = 52 cm</p>	M1 A1
20(b)	<p>1 cm ----- 0.2 km 1 cm² ----- 0.2² km² 1 cm² ----- 0.04 km² 6.7 cm² ----- 6.7×0.04 = 0.268 km²</p>	M1 A1
21(a)	<p><u>2014</u> 80% ----- 400 100% ----- $\frac{400}{80} \times 100$ = 500</p> <p><u>2015</u> 200% ----- 500 100% ----- $\frac{500}{200} \times 100$ = 250</p> <p>Ans: 250 Thousand</p>	M1 A1
21(b)	<ul style="list-style-type: none"> • The size of the pictogram symbol in 2016 is different from that of 2015. It becomes misleading that the number may be based on size of the symbols. • Each pictogram symbol in 2014/2015 represents thousand but symbol in 2016 represent million. • The decrease in number of symbols in the pictogram may appear to suggest that the number of commuters decreased when it actually increased in 2016. 	Any B1

MARKING SCHEME

Qn		Remarks
1a	$5(x^2 - 4)$ $= 5(x-2)(x+2)$	B1
b	$\frac{5(x-2)(x+2)}{(x-2)(x+1)}$ $= \frac{5(x+2)}{(x+1)}$	M1 A1
c	$\frac{3(y-3)-4(y+5)}{(y+5)(y-3)}$ $= \frac{-y-29}{(y+5)(y-3)}$	M1 A1
di	15	B1
dii	13	B1
diii	$15\frac{1}{3}$	B1
div	<p>Let the number of \$2 notes be x, then the number of \$10 notes is $20 - x$.</p> $2x + 10(20 - x) < 120$ $-8x < -80$ $x > 10$ <p>Minimum no. of \$2 notes = 11 Hence, number of \$10 notes = 9</p> <p>Total value = $11 \times 2 + 10 \times 9 = \\112</p>	B1 B1 B1
2a	$\frac{42}{x}$	B1
b	$\frac{42}{x-0.5}$ or $\frac{84}{2x-1}$	B1
c	$\frac{42}{x-0.5} - \frac{42}{x} = \frac{10}{60}$ $\frac{42x - 42(x-0.5)}{x(x-0.5)} = \frac{1}{6}$ $2x^2 - x - 252 = 0$	M1 A1



d	$x = \frac{-(-1) \pm \sqrt{(-1)^2 - 4 \times 2 \times (-252)}}{2(2)}$ $\frac{1 \pm \sqrt{2017}}{4}$ <p>= 11.4777 or -10.9777</p> <p>= 11.478 or -10.978 (3dp)</p>	M1 M1 A1 (Must be 3dp)
e	<p>$x = 11.478$ or -10.978 (reject)</p> <p>Lee's time = $\frac{42}{11.478}$</p> <p>= 3.65917 hours ≈ 3 hours 40 minutes</p>	M1 A1
3ai	a^2	B1
aii	$(2y^4)^3$ $= 8y^{12}$	M1 [$x^0=1$] A1
b	$2^{3x} = 2^4$ $3x = 4$ $x = \frac{4}{3}$	M1 A1
c	$a^3 \times a^4 \div a^{\frac{1}{2}} = a^k$ $a^7 \div a^{\frac{1}{2}} = a^k$ $a^{7-\frac{1}{2}} = a^k$ $k = 6.5$	M1 M1 A1
4a	5.44×10^{-5}	B1
bi	7.4×10^{10}	B1
bii	$7.4 \times 10^{10} \times 2^3$	M1



	$= 5.92 \times 10^{11}$	A1
c	$\frac{3}{10} \times 1800$ $= 540 \text{ g}$	M1 A1
d	Total Distance $= 1\frac{3}{4} \times 720 + 4 \times 650$ $= 3860 \text{ km}$ Total Time $= 1\frac{3}{4} + 4 = 5\frac{3}{4} \text{ h}$ Average Speed $= \frac{3860}{5\frac{3}{4}}$ $= 671 \text{ km/h (3 sf)}$	M1 M1 A1
5a		B2 Correct Triangle B1 Construct Lines
b	$\angle ACB = 57^\circ (\pm 1^\circ)$	B1
c	Correct angle bisector	B1
d	Correct perpendicular bisector	B1
e	$BX = 4.7 \text{ cm} (\pm 0.1^\circ)$	B1
6a	Gradient of $BC = \frac{8 - (-4)}{-2 - 6}$ $= -\frac{3}{2}$	B1
b	Length of $BC = \sqrt{(6 - (-2))^2 + (-4 - 8)^2}$ $= \sqrt{208}$ $= 14.4222$ $= 14.4 \text{ units (3 sf)}$	M1 A1
c	Area of $\triangle ABC = \frac{1}{2} \times 4 \times 8$ $= 16 \text{ units}^2$	M1 B1



d	$\frac{1}{2} \times BC \times h = 16$ $\frac{1}{2} \times 14.4222 \times h = 16$ $h = 2.2188$ $= 2.22 \text{ units (3 sf)}$	M1 A1
e	<p>Sub (-2, 4) into $y = -\frac{3}{2}x + c$</p> $4 = -\frac{3}{2}(-2) + c$ $c = 1$ $\therefore y = -\frac{3}{2}x + 1$	M1 A1
7a	$\frac{1}{2}(30 + 2r) \times 8 = 184$ $r = 8 \text{ (shown)}$	M1 A1
7b	<p>Volume of semi-circular prism</p> $= \frac{1}{2} \times \pi \times 8^2 \times 12 = 384\pi \text{ cm}^3$ <p>Volume of trapezoidal prism</p> $= 184 \times 12 = 2208 \text{ cm}^3$ <p>Total volume = $384\pi + 2208 = 3410 \text{ cm}^3$ (3 s.f.)</p>	M1 M1 A1
7c	$l^2 = 8^2 + 14^2$ $l = \sqrt{260}$ <p>Total surface area</p> $= (30 \times 12) + 12(\sqrt{260}) + 2(184) + 2\left(\frac{1}{2}\pi \times 8^2\right) + (8 \times 12)$ $+ (\pi \times 8) \times 12$ $= 1520.149011 \text{ cm}^2$ <p>Cost = $1520.149011 \times \\$0.02$</p> $= \$30.40$	M1 M2 M1 A1



8ai	$T_4 = 4^3 + 12 = 76$	B1
aii	$T_n = n^3 + 3n$	B1 , B1
aiii	$T_{60} = 60^3 + 3(60)$ $= 216\ 180$	B1
b	$P_n = 4n + 1$	B1
c	$\frac{T_n}{P_n} = \frac{n^2}{4}$ $\frac{n^3 + 3n}{4n + 1} = \frac{n^2}{4}$ $4n^2 + 12n = 4n^3 + n^2$ $n^2 - 12n = 0$ $n(n - 12) = 0$ $n = 0 \quad \text{or} \quad n = 12$	M1 M1 A1
9a	<p>Acceleration</p> $= \frac{24 - 50}{40 - 0}$ $= -0.65 \text{ m/s}^2$ <p>\therefore Deceleration</p> $= 0.65 \text{ m/s}^2$	M1 A1
b	$-0.65 = \frac{S - 50}{30 - 0}$ $S = 30.5 \text{ m/s}$	M1 A1
c	<p>Total distance travelled</p> $= \frac{1}{2} \times (50 + 24) \times 40 + (30 \times 24) + \left(\frac{1}{2} \times 20 \times 24\right)$ $= 2440 \text{ m}$	M2 A1
d	<p>Average speed of whole journey</p> $= \frac{2440}{90}$ $= 27.1 \text{ m/s (3.s.f)}$	M1 A1



10i	$p = 19$ $q = 22$	B1 B1
ii		B1 Scale B1 Plot B1 Curve
iii	$x = 0.75$ (accept 0.70 to 0.80)	B2
iv	(accept -2.80 to -2.90) and (accept 4.20 to 4.30)	B2
11i	Net price: pump price $= \$2.28 : \2.40 $= 228 : 240$ $= 228 (\div 12) : 240 (\div 12)$ $= 19 : 20$ (Shown)	B1
ii	$x = \$2.09 \times \frac{19}{20}$ $= \$1.9855$ $= \$1.99$ (2dp)	B1



c	<p>Total discount Ronnie got = $(\\$2.09 - \\$1.99) \times 45$ = \$4.50</p>	<p>Alternatively: $45(\\$2.09) = \\94.05</p>	B1
	<p>Extra amount of fuel pumped = $\frac{4.50}{1.99}$ = 2.261306 L</p>	<p>$\frac{94.05}{1.99} - 45 = 2.261306 \text{ L}$</p>	B1
	<p>Further distance that Ronnie could travel = 2.261306×20.8156 = 47.0704 = 47 km</p>		B1
	<p>Ronnie's claim was correct.</p>		B1