

*Visit*

**FREETESTPAPER.com**

*for more papers*



Website: [freetestpaper.com](http://www.freetestpaper.com)



[Facebook.com/freetestpaper](https://www.facebook.com/freetestpaper)



[Twitter.com/freetestpaper](https://www.twitter.com/freetestpaper)



**NORTH VISTA SECONDARY SCHOOL**  
**END-OF-YEAR EXAMINATION 2021**

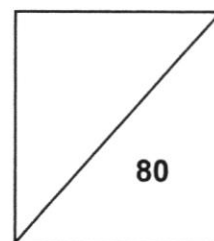

**NAME:** \_\_\_\_\_ (       ) **CLASS:** \_\_\_\_\_

**SUBJECT: ELEMENTARY MATHEMATICS (PAPER 1)**      **DATE: 4 OCTOBER**

**LEVEL / STREAM: SECONDARY 3 EXPRESS**                      **TIME: 2 HOURS**

**SUBJECT CODE: 4048/01**

**READ THESE INSTRUCTIONS FIRST**

Write your name, register number and class on all the work you hand in.

Write in dark blue or black pen.

You may use a pencil for any diagrams or graphs.

Do not use staples, paper clips, glue or correction fluid.

Answer **all** questions.

If working is needed for any question, it must be shown with the answer.

Omission of essential working will result in loss of marks.

The use of an approved scientific calculator is expected, where appropriate.

If the degree of accuracy is not specified in the question, and if the answer is not exact, give the answer to three significant figures. Give answers in degree to one decimal place.

For  $\pi$ , use either your calculator value or 3.142, unless the question requires answer in terms of  $\pi$ .

At the end of the examination, fasten all your work securely together.

The number of marks is given in brackets [ ] at the end of each question or part question.

The total of the marks for this paper is **80**.

<i>For Examiner's Use</i>	
<b>Category</b>	<b>Question No.</b>
Accuracy	
Brackets	
Fractions	
Units	
Others	
<b>Marks Deducted</b>	

This question paper consists of **19** printed pages.

**[Turn over**

**Mathematical Formulae***Compound Interest*

$$\text{Total amount} = P \left( 1 + \frac{r}{100} \right)^n$$

*Mensuration*

$$\text{Curved surface area of a cone} = \pi r l$$

$$\text{Surface area of a sphere} = 4\pi r^2$$

$$\text{Volume of a cone} = \frac{1}{3} \pi r^2 h$$

$$\text{Volume of a sphere} = \frac{4}{3} \pi r^3$$

$$\text{Area of triangle } ABC = \frac{1}{2} ab \sin C$$

$$\text{Arc length} = r\theta, \text{ where } \theta \text{ is in radians}$$

$$\text{Sector area} = \frac{1}{2} r^2 \theta, \text{ where } \theta \text{ is in radians}$$

*Trigonometry*

$$\frac{a}{\sin A} = \frac{b}{\sin B} = \frac{c}{\sin C}$$

$$a^2 = b^2 + c^2 - 2bc \cos A$$

*Statistics*

$$\text{Mean} = \frac{\Sigma fx}{\Sigma f}$$

$$\text{Standard deviation} = \sqrt{\frac{\Sigma fx^2}{\Sigma f} - \left( \frac{\Sigma fx}{\Sigma f} \right)^2}$$

3

Answer **all** questions.

- 1 (a) Arrange the following in ascending order.

$$3\frac{7}{50}, \pi, 3.142, 3.\dot{1}\dot{4}$$

*Answer* ..... , ..... , ..... , ..... [1]

- (b) Write down the number that is exactly halfway between  $\frac{1}{2}$  and  $\frac{7}{8}$ .

*Answer* ..... [1]

---

- 2 Given that  $27^{n-1} = 1$ , find the value of  $n$ .

*Answer*  $n =$  ..... [2]

---

[Turn over

3

$y = 2^x$	$y = \frac{3}{x}$	$y = x^2 - 3x + 2$
$y = \frac{2}{x^2}$	$y = x^3 + 4$	$y = 3 - x^3$

Write down a possible equation for each of the sketch graphs below.  
In each case, select one of the equations from the box above.

(a)

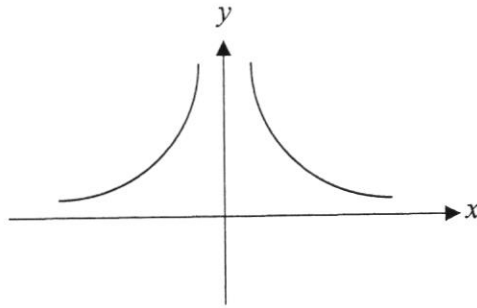

Answer ..... [1]

(b)

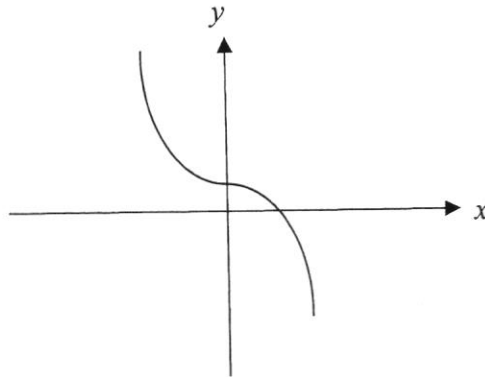

Answer ..... [1]

4

(a) The equation of the line  $l_1$  is  $x + 4 = 0$ .

State the length of the shortest distance between  $l_1$  and the point  $(5, -1)$ .

Answer ..... units [1]

(b) Find the equation of the line that is parallel to the  $x$ -axis and passes through the point  $(4, 7)$ .

Answer ..... [1]

5

- 5 (a) Written as a product of its prime factors,  $3500 = 2^x \times 5^y \times 7$ .  
Find the values of  $x$  and  $y$ .

Answer  $x = \dots\dots\dots$

$y = \dots\dots\dots$  [2]

- (b) The number  $3500k$  is a perfect cube.  
Find the smallest positive integer value of  $k$ .

Answer  $k = \dots\dots\dots$  [1]

- 6 A container is filled with water until 70% full.  
20% of the water in the container is used.  
There are 476 litres of water left in the container.

Calculate the capacity of the container when full.

Answer  $\dots\dots\dots$  litres [2]

[Turn over

6

- 7 An equality in  $x$  is represented on the number line below. The markings on the number line are at equal intervals.

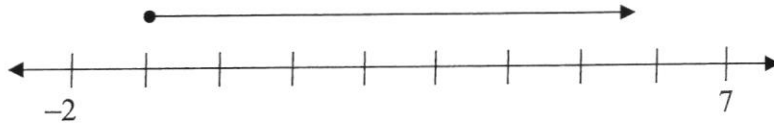

- (a) State the inequality in  $x$ .

*Answer* ..... [1]

- (b) State the smallest prime number satisfying the inequality.

*Answer* ..... [1]

- 8 Expand and simplify the following algebraic expressions.

(a)  $2(x+3y)-5y$ ,

*Answer* ..... [1]

(b)  $4x-x(3-y)$ .

*Answer* ..... [1]

- 9 The value of  $x^2 - y^2 = 12$ .  
Given that  $x$  and  $y$  are positive integers and  $x > y$ , find the value of  $x$  and of  $y$ .

*Answer*  $x = \dots\dots\dots y = \dots\dots\dots$  [2]

---

- 10 Jane borrowed \$8000 from Bank A for 3 years.  
Bank A charges 1.5% compound interest per annum compounded quarterly.  
Jane would have paid the same amount of interest if she borrowed money from Bank B for 3.5 years, which charges simple interest of  $r\%$  per annum. Find  $r$ .

*Answer*  $r = \dots\dots\dots$  [4]



---

[Turn over

- 11 A supermarket sells a particular type of fresh milk in two different types of packaging at different prices as shown below.

Andrea said that it is more cost saving to buy Package A.

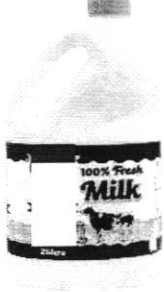
Do you agree? Explain your answer by showing your working clearly.

Package A	Package B
 <p data-bbox="435 853 655 920">2 Litres Price: 1 for \$6.34</p>	 <p data-bbox="935 853 1155 920">830 ml Price: 2 for \$5.85</p>

*Answer*

[3]

- 12 If  $x = -5$  is a solution of the equation  $2x^2 + 9x - a = 0$ , find the other solution of the equation.

*Answer*  $x = \dots\dots\dots$  [3]

---

- 13 (a) Express  $x^2 + 6x + 1$  in the form  $(x + a)^2 + b$ .

*Answer*  $\dots\dots\dots$  [2]

- (b) Write down the coordinates of the minimum point on the graph of  $y = x^2 + 6x + 1$ .

*Answer* ( $\dots\dots\dots$ ,  $\dots\dots\dots$ ) [1]

---

- 14 The diagram shows a trapezium  $ABCD$  with  $AB \parallel DC$ .  
 $D$  is due south of  $A$ . Angle  $DCB = 145^\circ$  and angle  $BAD = 110^\circ$ .

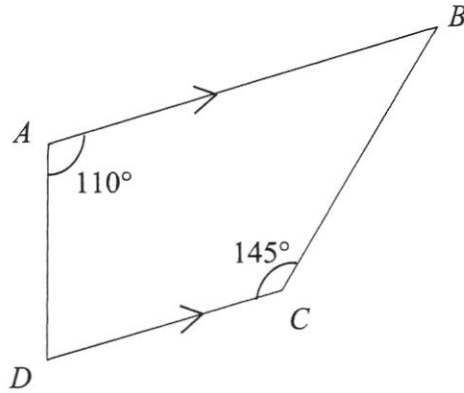

- (a) Find the bearing of  $B$  from  $A$ .

Answer ..... [1]

- (b) Find the bearing of  $C$  from  $B$ .

Answer ..... [2]

- 15 Factorise completely

(a)  $10pq^2 - 14p^3q^2$ ,

Answer ..... [1]

(b)  $4ax - 2bx + 6ay - 3by$ .

Answer ..... [2]

- 16 In the figure below,  $ABC$  is a straight line.  
 It is given that  $BD = 15$  cm,  $DC = 8$  cm and  $BC = 17$  cm.

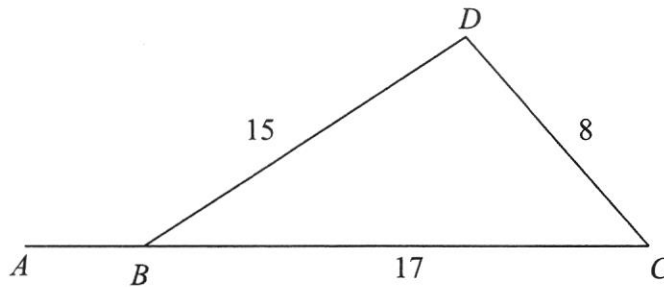

- (a) Show that triangle  $BCD$  is a right-angled triangle.

Answer .....  
 .....  
 .....  
 ..... [2]

- (b) Express the following as a fraction in its simplest form.

(i)  $\cos \angle CBD$

Answer  $\cos \angle CBD = \dots\dots\dots$  [1]

(ii)  $\sin \angle ABD$

Answer  $\sin \angle ABD = \dots\dots\dots$  [1]

17 (a) Given  $x$  and  $y$  are integers such that  $-2 \leq x \leq 5$  and  $-5 \leq y \leq 4$ , find

(i) the largest possible value of  $xy^2$ ,

*Answer* ..... [1]

(ii) the smallest possible value of  $\frac{3x}{y}$ .

*Answer* ..... [1]

(b) Solve the inequality  $\frac{3x+5}{4} < \frac{4x-3}{2}$ .

*Answer* ..... [2]

---

18

Country	Monaco	Singapore	Hong Kong
Population	$3.951 \times 10^4$	$5.897 \times 10^6$	$7.553 \times 10^6$
Land Area (km <sup>2</sup> )	2.01	$7.103 \times 10^2$	$1.104 \times 10^3$

- (a) Using information from the table above, find how many more people lived in Singapore than in Monaco, giving your answer in standard form correct to 3 significant figures.

*Answer* ..... [2]

- (b) Given that Population Density =  $\frac{\text{Population}}{\text{Land Area}}$ , determine whether Hong Kong or Singapore has a higher population density. Justify your answer with calculations.

*Answer*

[2]

[Turn over

- 19 (a) Sketch the graph of  $y = (x+2)(3-x)$  on the axes below.  
Indicate clearly the values where the graph crosses the  $x$ - and  $y$ - axes.

*Answer*

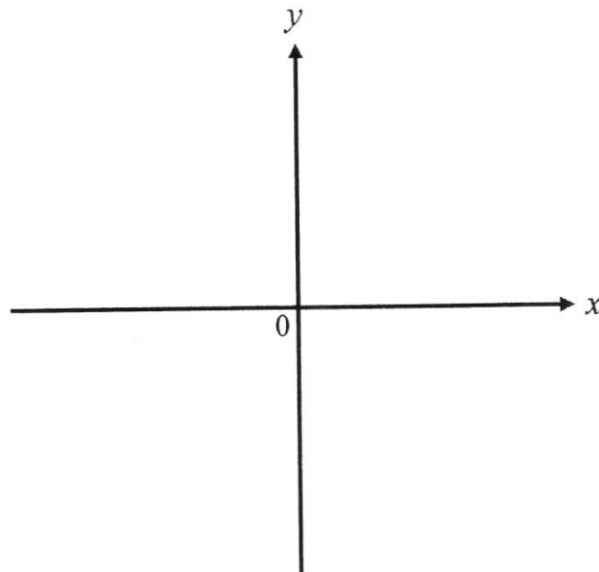

[2]

- (b) Write down the equation of the line of symmetry of the graph.

*Answer* ..... [1]

- (c) Find the coordinates of the turning point.

*Answer* (....., .....) [1]

- 20 (a) Solve the equation  $\frac{x-1}{3} + \frac{x}{5} = 1$

*Answer*  $x =$  ..... [2]

15

20 (b) Solve these simultaneous equations.

$$\frac{x}{2} + 4y = 15$$

$$x - y = 3$$

*Answer*  $x = \dots\dots\dots$

$y = \dots\dots\dots$  [3]

---

- 21 A container is made up of a cylinder and a cone which has a height of 20 cm each. Water is poured into the empty container at a constant rate. It takes 14 seconds to fill up the container.

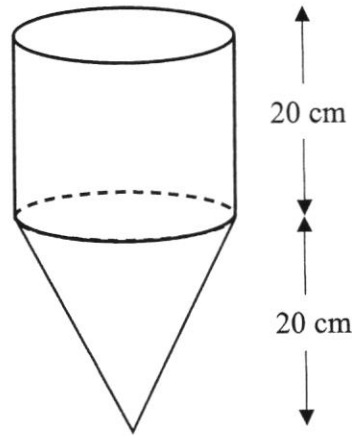

- (a) How long does it take to fill up the entire cone?

Answer ..... s [1]

- (b) On the axes in the answer space, sketch the graph showing how the depth of the water in the container varies over the 14 seconds.

Answer

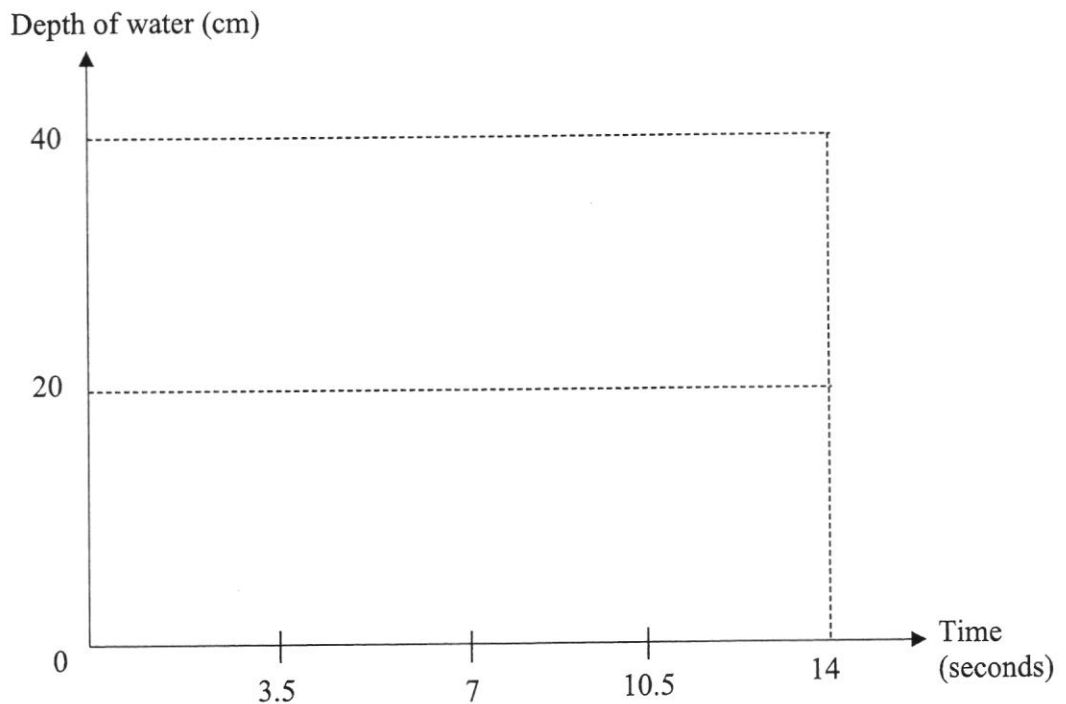

[2]

22 A solid cuboid has length 25 cm, width 12 cm and height 8 cm.

(a) Calculate the total surface area of the cuboid.

*Answer* ..... cm<sup>2</sup> [2]

(b) A tin of paint can cover an area of 60 000 cm<sup>2</sup>. How many cuboids can be completely painted using just 1 tin of paint?

*Answer* ..... [2]

(c) State one assumption made in your calculations to part (b).

*Answer* .....  
.....  
.....[1]

[Turn over

23 (a) It is given that  $T = \sqrt{\frac{A^2 + 41}{B}}$ .

(i) Find the value of  $T$  when  $A = -3$  and  $B = 2$ .

*Answer*  $T = \dots\dots\dots$  [1]

(ii) Express  $A$  in terms of  $B$  and  $T$ .

*Answer*  $\dots\dots\dots$  [3]

(b) Simplify  $\frac{x^2 - x - 2}{3x^2 - 12}$ .

*Answer*  $\dots\dots\dots$  [3]

- 24 In the diagram,  $ABCD$  is a square of side  $\sqrt{3}$  cm.  $BE$  is an arc of a circle with centre  $A$  and radius  $\sqrt{3}$  cm.

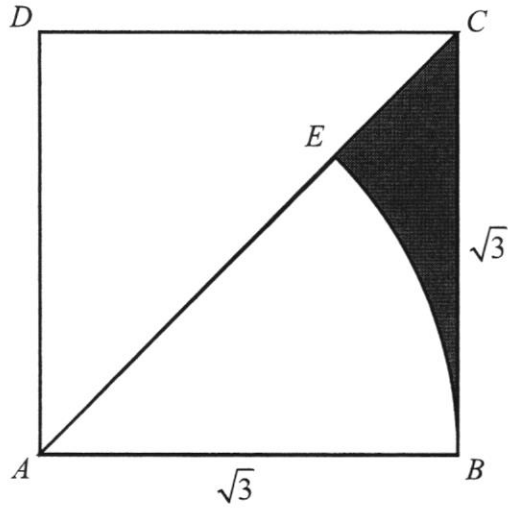

- (a) Calculate the perimeter of the shaded region  $BEC$ .

Answer ..... cm [3]

- (b) Find the area of the shaded region  $BEC$ .

Answer .....  $\text{cm}^2$  [3]

---

**End of Paper**



**NORTH VISTA SECONDARY SCHOOL**  
**END-OF-YEAR EXAMINATION 2021**

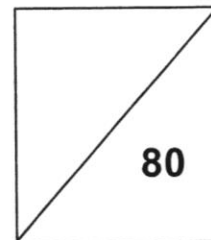

**NAME:** \_\_\_\_\_ (     )     **CLASS:** \_\_\_\_\_

**SUBJECT: ELEMENTARY MATHEMATICS (PAPER 2)**     **DATE: 6 OCTOBER**

**LEVEL / STREAM: SECONDARY 3 EXPRESS**     **TIME: 2 HOURS**

**SUBJECT CODE: 4048/02**

**READ THESE INSTRUCTIONS FIRST**

Write your register number and name on all the work you hand in.  
 Write in dark blue or black pen.  
 You may use a pencil for any diagrams or graphs.  
 Do not use staples, paper clips, glue or correction fluid.

Answer **all** questions.

If working is needed for any question, it must be shown with the answer.  
 Omission of essential working will result in loss of marks.

The use of an approved scientific calculator is expected, where appropriate.

If the degree of accuracy is not specified in the question, and if the answer is not exact, give the answer to three significant figures. Give answers in degrees to one decimal place.

For  $\pi$ , use either your calculator value or 3.142, unless the question requires the answer in terms of  $\pi$ .

The number of marks is given in brackets [ ] at the end of each question or part question.  
 The total of the marks for this paper is 80.

<i>For Examiner's Use</i>	
<b>Category</b>	<b>Question No.</b>
Accuracy	
Brackets	
Fractions	
Units	
Others	
<b>Marks Deducted</b>	

This paper consists of **22** printed pages.

[Turn over

*Mathematical Formulae**Compound Interest*

$$\text{Total amount} = P \left( 1 + \frac{r}{100} \right)^n$$

*Mensuration*

$$\text{Curved surface area of a cone} = \pi r l$$

$$\text{Surface area of a sphere} = 4\pi r^2$$

$$\text{Volume of a cone} = \frac{1}{3} \pi r^2 h$$

$$\text{Volume of a sphere} = \frac{4}{3} \pi r^3$$

$$\text{Area of triangle } ABC = \frac{1}{2} ab \sin C$$

$$\text{Arc length} = r\theta, \text{ where } \theta \text{ is in radians}$$

$$\text{Sector area} = \frac{1}{2} r^2 \theta, \text{ where } \theta \text{ is in radians}$$

*Trigonometry*

$$\frac{a}{\sin A} = \frac{b}{\sin B} = \frac{c}{\sin C}$$

$$a^2 = b^2 + c^2 - 2bc \cos A$$

*Statistics*

$$\text{Mean} = \frac{\sum fx}{\sum f}$$

$$\text{Standard Deviation} = \sqrt{\frac{\sum fx^2}{\sum f} - \left( \frac{\sum fx}{\sum f} \right)^2}$$

Answer all the questions.

- 1 (a) Write as a single fraction in its simplest form  $\frac{4}{(x-5)^2} + \frac{3}{5-x}$ .

*Answer* ..... [3]

- (b) Simplify  $\left(\frac{x^{16}}{36y^6}\right)^{-\frac{1}{2}}$ .

*Answer* ..... [2]

**[Turn over**

- 1 (c) Given that  $9^{k-1} = 27 \times \sqrt{3^k}$ , find the value of  $k$ .

*Answer*  $k = \dots\dots\dots$  [3]

- 2 Janet spends a certain amount of money for her monthly petrol bill.

- (a) In April, the price of petrol was \$ $x$  per litre.  
Janet paid \$560 for her petrol bill that month.

Write an expression, in terms of  $x$ , for the number of litres of petrol used by Janet in April.

*Answer*  $\dots\dots\dots$  litres [1]

- (b) In May, the price of petrol was decreased by \$0.30 per litre.  
Janet still paid \$560 for her petrol bill that month.

Write an expression, in terms of  $x$ , for the number of litres of petrol used by Janet in May.

*Answer*  $\dots\dots\dots$  litres [1]

- 2 (c) Janet used 20 litres of petrol more in May than in April.  
Write down an equation in  $x$  and show that it reduces to  $20x^2 - 6x - 168 = 0$ .

*Answer*

- (d) Solve the equation  $20x^2 - 6x - 168 = 0$ , giving your solutions correct to two decimal places. [3]

*Answer*  $x = \dots\dots\dots$  or  $\dots\dots\dots$  [3]

- 2 (e) Find the number of litres of petrol used by Janet in April.

Answer ..... litres [1]

- 3 The points  $P(-5, -3)$ ,  $S(10, 15)$  and  $T(2, -3)$  are shown in the diagram below.

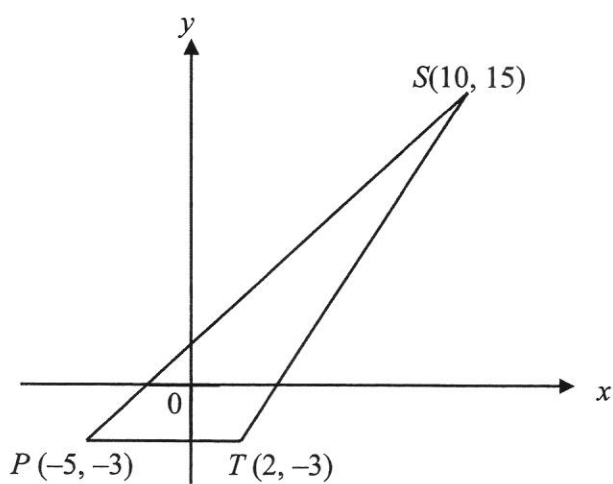

- (a) Find the gradient of line  $SP$ .

Answer ..... [1]

- 3 (b) Find the equation of a line which is parallel to  $SP$  and passes through point  $T$ .

*Answer* ..... [2]

- (c) A point  $B$ , with coordinates  $(2, y)$  is such that the area of triangle  $PTB$  is  $42 \text{ units}^2$ . Find the values of  $y$ .

*Answer*  $y = \dots\dots\dots$  or  $\dots\dots\dots$  [3]

[Turn over

- 4 The diagram shows a speed time graph of an object  $A$  during a period of 40 seconds.

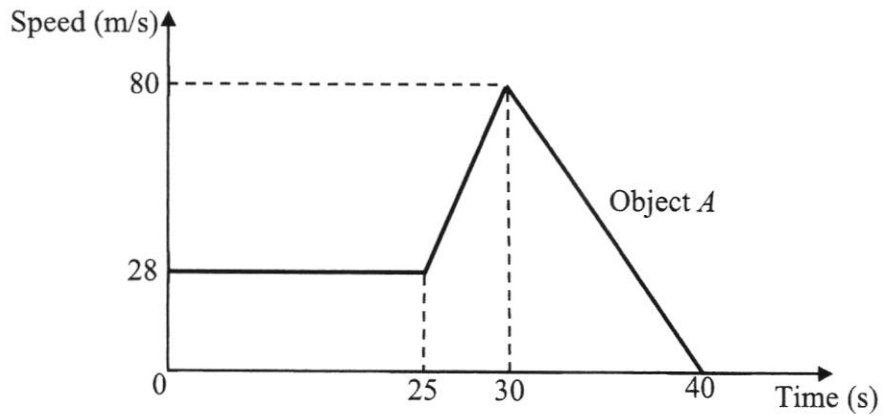

- (a) Calculate the deceleration of object  $A$  when the time is 36 seconds.

*Answer* .....  $\text{m/s}^2$  [2]

- (b) Calculate the speed of object  $A$  at 27 seconds.

*Answer* .....  $\text{m/s}$  [2]

- 4 (c) Object *B* started its journey from the same place and same time as object *A*. It accelerated uniformly and met object *A* when the time is 30 seconds. Calculate the speed of object *B* when it met up with object *A*.

Answer ..... m/s [2]

- (d) On the axes in the answer space, sketch the distance-time graph of object *A* for the first 40 seconds of the motion, labelling your distance-axis clearly.

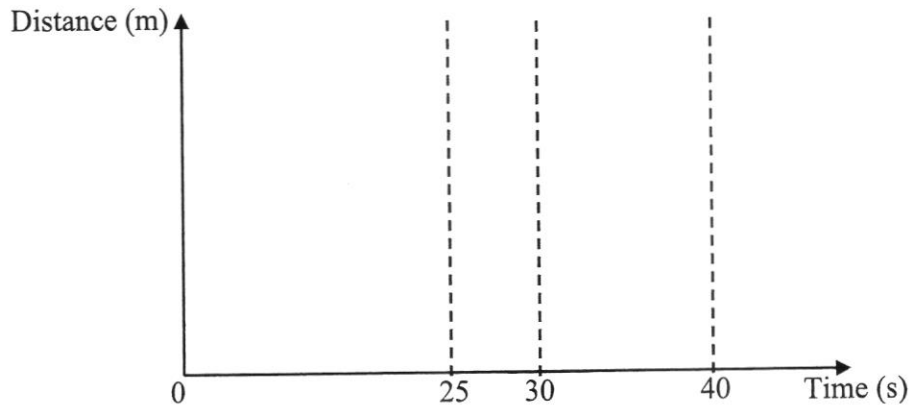

[3]

[Turn over

- 5 The diagram shows a metal tin with a uniform cross-section  $ANBCD$ .  $ABCD$  is a rectangle,  $O$  is the midpoint of  $DC$  and  $ANB$  is an arc of a circle with centre  $O$ .  $AB = 10$  cm,  $AD = 12$  cm and the length of the metal tin is 28 cm.

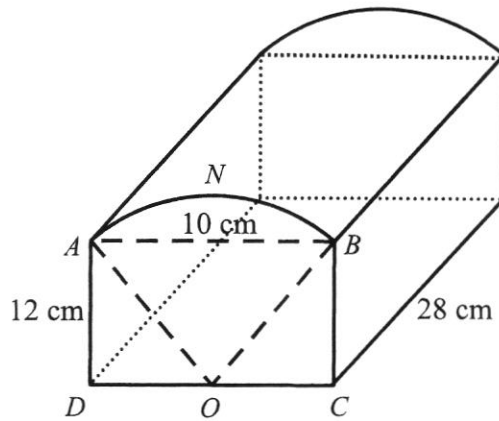

- (a) Show that acute angle  $AOB = 0.790$  radians, correct to 3 significant figures.  
*Answer*

[2]

- 5 (b) Calculate
- (i) the area of segment  $ANB$ ,

*Answer* .....  $\text{cm}^2$  [4]

- (ii) the total volume of the metal tin.

*Answer* .....  $\text{cm}^3$  [2]

- 6 In the diagram,  $ABCD$  is the base of a cuboid  $ABCDPQRS$ .  
 $RC = 32$  cm and  $AB = BC = 10$  cm.

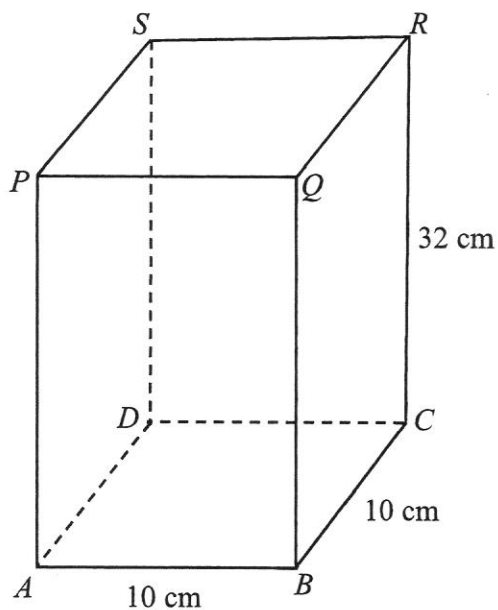

- (a) Calculate the length  $AC$ .

Answer ..... cm [1]

- (b) If the cuboid is inscribed in a sphere of radius  $r$  cm such that all the vertices  $A, B, C, D, P, Q, R$  and  $S$  are on the surface of the sphere.

- (i) Find the value of  $r$ .

Answer ..... cm [2]

- 6 (b) (ii) Calculate the volume of the sphere.

*Answer* .....  $\text{cm}^3$  [1]

- 7 The variables  $x$  and  $y$  are connected by the equation  $y = \frac{x^2}{5} + \frac{15}{x} - 8$ .

The table below shows some values of  $x$  and the corresponding values of  $y$ .

$x$	1	1.5	2	3	4	5	6	7
$y$	7.2	2.45	0.3	-1.2	-1.05	0	$p$	3.9

- (a) Find the value of  $p$ .

*Answer*  $p = \dots\dots\dots$  [1]

- (b) On the grid on the next page, draw the graph of  $y = \frac{x^2}{5} + \frac{15}{x} - 8$  for  $1 \leq x \leq 7$ . [3]

- (c) By drawing a tangent, find the gradient of the curve at  $x = 2$ .

*Answer*  $\dots\dots\dots$  [2]

- (d) Use your graph to find the solution of the equation  $\frac{x^2}{5} + \frac{15}{x} - 8 = 5$  in the range  $1 \leq x \leq 7$ .

*Answer*  $x = \dots\dots\dots$  [1]

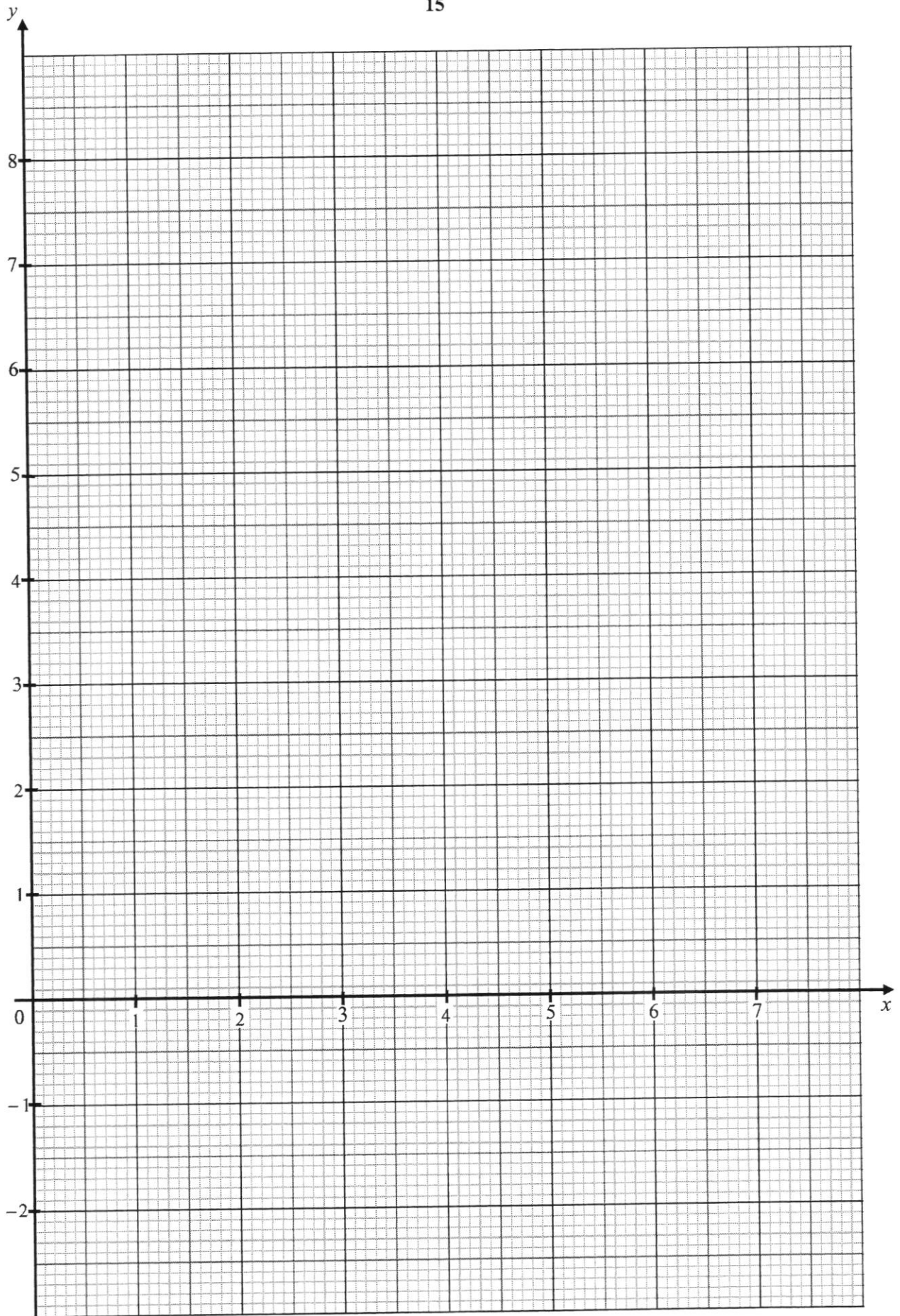

[Turn over

- 7 (e) (i) On the grid in part (b), draw the line  $y = -\frac{1}{2}x + 4$  for  $1 \leq x \leq 7$ .

[2]

- (ii) Write down the  $x$ -coordinates of the points where the two graphs intersect.

*Answer*  $x = \dots\dots\dots$  or  $\dots\dots\dots$  [2]

- (iii) Given that these values of  $x$  are the solutions of the equation

$$2x^3 + Ax^2 + Bx + 150 = 0,$$

find the value of  $A$  and the value of  $B$ .

*Answer*  $A = \dots\dots\dots$

$B = \dots\dots\dots$  [2]

- 8  $P, Q, R$  and  $S$  are four points on level ground.  $P$  is due west of  $Q$  and the bearing of  $Q$  from  $R$  is  $158^\circ$ .  $SP = 94$  m,  $PQ = 240$  m,  $QR = 135$  m and angle  $PSR = 46^\circ$ .

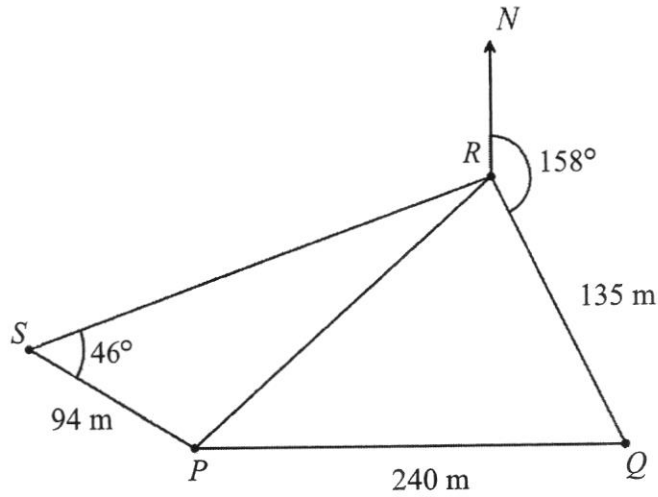

- (a) Show that angle  $PQR = 68^\circ$ , stating your reasons clearly.

*Answer*

[2]

- (b) Calculate  
 (i) the distance  $PR$ ,

*Answer* ..... m [3]

[Turn over

8 (b) (ii) angle  $PRS$ ,

*Answer* ..... [2]

(iii) the area of triangle  $PQR$ ,

*Answer* .....  $\text{m}^2$  [2]

- 8 (b) (iv) the shortest distance from  $R$  to  $PQ$ .

*Answer* ..... m [2]

- (c) A vertical tower of height 42 m stands at the point  $R$ .  
Find the greatest angle of elevation of the top of the tower from a person walking along  $PQ$ .

*Answer* ..... [2]

[Turn over

- 9 Jackie wants to set up a buffet restaurant, where each buffet set consists of free flow of meat, vegetables and soft drinks.

Jackie needs to decide how much he should charge each customer for a buffet meal. In order to do so, he did a market survey.

Market Survey	
<b>Estimated number of customers per day</b>	200 customers [ <b>Assumption:</b> Exactly half of the daily customers belong to group A and the other half belong to group B.]
<b>Dietary behaviours</b>	<u>Group A</u> Consumes at most 2.5 kg of meat per person.  <u>Group B</u> Consumes at most 400 g of meat and 350 g of vegetables per person.
<b>Drink consumption per customer</b>	About 600ml of soft drinks per person.

Cost of food supplies (costs excluding 7% GST)		
Item	Description	Unit cost
Meat	Per kg	\$5.20
	Minimum order of at least 250kg	\$4.90
	Minimum order of at least 400kg	\$4.70
Vegetables	Per kg	\$0.80
	Minimum order of at least 15kg	\$0.70
	Minimum order of at least 25kg	\$0.60
Soft drinks	Per bottle (1 litre each)	\$1.80
	1 box of 100 bottles	\$120
Note: <ul style="list-style-type: none"> <li>• Cost of food supplies should take up maximum 30% of your buffet pricing.</li> <li>• Buffet pricing should be inclusive of GST.</li> </ul>		

- 9 (a) Estimate the maximum amount of vegetables (kg) that will be consumed in a day.

*Answer* ..... kg [1]

- (b) Estimate the maximum amount of meat (kg) that will be consumed in a day.

*Answer* ..... kg [1]

- 9 (c) Using only the information provided, suggest a reasonable amount for Jackie to charge for a buffet per person.

Justify the decision you make and show your calculations clearly.

*Answer*

.....

.....

.....

.....[8]

---

**End of Paper**

**Marking Scheme for Sec 3 Paper 1 2021**

1a	$3\frac{7}{50}, 3.14, \pi, 3.142$
1b	$\frac{11}{16}$
2	$27^{n-1} = 1$ $(3^3)^{n-1} = 1$ $3^{3n-3} = 3^0$ $n = 1$
	$27^{n-1} = 27^0$ $n - 1 = 0$ $n = 1$
3a	$y = \frac{2}{x^2}$
3b	$y = 3 - x^3$
4a	9
4b	$y = 7$
5a	$3500 = 2^2 \times 5^3 \times 7$ $x=2, y=3$
5b	$k = 2 \times 7^2 = 98$
6	Amount of water in the container = $\frac{476}{80} \times 100$ = 595 litres Capacity of container = $\frac{595}{70} \times 100 = 850$ litres
7a	$x \geq -1$ (OR $-1 \leq x$ )
7b	2
8a	$2(x+3y) - 5y = 2x + y$
8b	$4x - x(3-y) = x + xy$
9	$x^2 - y^2 = 12$ $(x+y)(x-y) = 12$ $(4)(3) = 12$ OR $(6)(2) = 12$ OR $(12)(1) = 12$ $\therefore x = 4, y = 2$
10	$A = 8000 \left(1 + \frac{1.5}{100}\right)^{12}$ $= 8000 \left(1 + \frac{1.5}{400}\right)^{12}$ $= 8367.5186$

	<p>Interest = 367.5186</p> $367.5186 = \frac{8000 \times r \times 3.5}{100}$ $r = \frac{367.5186 \times 100}{8000 \times 3.5}$ $= 1.31 \text{ (3 sf)}$
11	<p>Packing A</p> $\frac{6.34}{2000} = \$0.00317 / ml$ <p>Packing B</p> $\frac{5.85}{2 \times 830} = \frac{5.85}{1660} = \$0.003524 / ml$ <p>Yes, agree. Packing A is cheaper.</p> <p><b>OR</b></p> <p>Packing B</p> $\frac{5.85}{1660} \times 2000 = \$7.05 \text{ for 2 litres (M2, A1 for agreeing)}$
12	$2(-5)^2 + 9(-5) - a = 0$ $a = 5$ $2x^2 + 9x - 5 = 0$ $(x+5)(2x-1) = 0$ $x = \frac{1}{2}$
13a	$x^2 + 6x + 1$ $= (x+3)^2 + 1 - 3^2$ $= (x+3)^2 - 8$
13b	$(-3, -8)$
14a	$070^\circ$
14b	$\left. \begin{array}{l} \angle ABC = 180 - 145 = 35^\circ \\ \angle ABN = 180 - 70 = 110^\circ \end{array} \right\} \text{ or } \left. \begin{array}{l} \angle NCB = 145 - 110 = 35^\circ \\ \angle CBS = 35^\circ \end{array} \right\}$ $\text{bearing} = 360 - 110 - 35 = 215^\circ \quad \text{Bearing} = 180 + 35 = 215^\circ$
15a	$10pq^2 - 14p^3q^2$ $= 2pq^2(5 - 7p^2)$

15b	$4ax - 2bx + 6ay - 3by$ $= 2x(2a - b) + 3y(2a - b)$ $= (2x + 3y)(2a - b)$
16a	$BC^2 = 17^2 = 289$ $BD^2 + DC^2 = 15^2 + 8^2 = 289$ <p>Since <math>BC^2 = BD^2 + DC^2</math>, by the Converse of Pythagoras theorem, triangle <math>BCD</math> is a right-angled triangle.</p>
16bi	$\frac{15}{17}$
16bii	$\frac{8}{17}$
17ai	largest $xy^2 = (5)(-5)^2 = 125$
17aii	smallest $\frac{3x}{y} = \frac{3(5)}{-1} = -15$
17b	$\frac{3x+5}{4} < \frac{4x-3}{2}$ $2(3x+5) < 4(4x-3)$ $6x+10 < 16x-12$ $22 < 10x$ $2\frac{1}{5} < x$
18a	$(5.897 \times 10^6) - (3.951 \times 10^4) = 5.86 \times 10^6$
18b	<p><b>Hong Kong</b></p> $\text{Density}_{HK} = \frac{7.553 \times 10^6}{1.104 \times 10^3}$ $= 6841.485507$ <p><b>Singapore</b></p> $\text{Density}_{SG} = \frac{5.897 \times 10^6}{7.103 \times 10^2}$ $= 8302.125862$ <p>Singapore has a higher population density.</p>

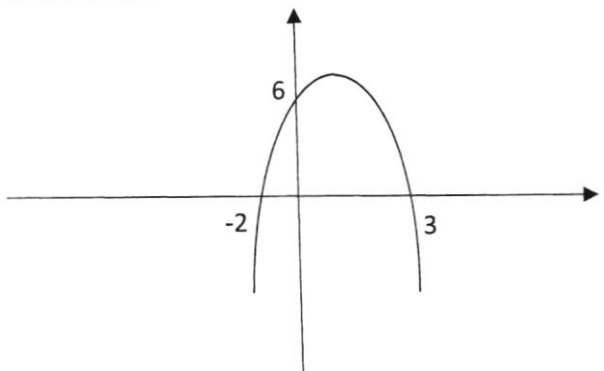
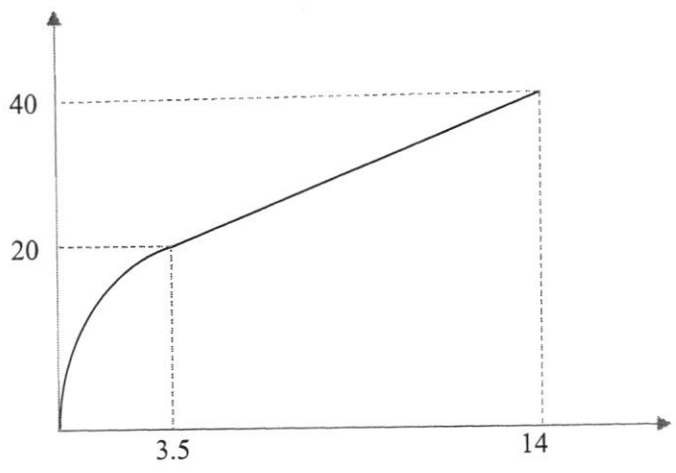
19a	
19b	$x = 0.5$
19c	$(0.5, 6.25)$ or $(\frac{1}{2}, 6\frac{1}{4})$
20a	$\frac{x-1}{3} + \frac{x}{5} = 1$ $\frac{5(x-1)+3x}{15} = 1 \quad \text{or} \quad \frac{5(x-1)}{15} + \frac{3x}{15} = 1$ $8x - 5 = 15$ $x = 2.5$
20b	$\frac{x}{2} + 4y = 15 \quad \text{----(1)}$ $x - y = 3 \quad \text{----(2)}$ $(1) \times 2, x + 8y = 30 \quad \text{----(3)}$ $(3) - (2), 9y = 27$ $y = 3$ $x = 6$
21a	$\frac{14}{4} = 3.5s$
21b	

22a	$2(25 \times 12) + 2(25 \times 8) + 2(12 \times 8)$ $= 1192$
22b	$\frac{60000}{1192} = 50 \frac{50}{149} \text{ or } 50.33557047 \text{ or } \frac{7500}{149}$ <p>50 cuboids</p>
22c	<p>Any logical answer</p> <p>The amount of paint used for each cuboid is <b>exactly</b> 1192.</p> <p>There is no spillage of paint.</p> <p>The thickness of paint used for <b>each</b> cuboid is the same.</p> <p>The <b>total</b> surface area of <b>each</b> cuboid is <b>exactly</b> the same.</p>
23ai	5
23aii	$T = \sqrt{\frac{A^2 + 41}{B}}$ $T^2 = \frac{A^2 + 41}{B}$ $A^2 = T^2 B - 41$ $A = \pm \sqrt{T^2 B - 41}$
23b	$\frac{x^2 - x - 2}{3x^2 - 12} = \frac{(x-2)(x+1)}{3(x+2)(x-2)}$ $= \frac{x+1}{3(x+2)}$
24a	$AC = \sqrt{3+3} = \sqrt{6}$ $EB = \frac{1}{8}(2 \times \pi \times \sqrt{3}) = 1.360349$ $\text{Perimeter} = \sqrt{3} + 1.360349 + (\sqrt{6} - \sqrt{3})$ $= 3.81 \text{ cm (3 sf)}$
24b	$\text{Area of sector} = \frac{1}{8}(\pi)(\sqrt{3})^2$ $= \frac{3\pi}{8} \quad (\text{or } 1.178097) \quad \text{or} \quad \frac{1}{2}(\sqrt{3})^2 \left(\frac{\pi}{4}\right)$ $\text{Area of shaded region} = \frac{1}{2}(\sqrt{3} \times \sqrt{3}) - \frac{3\pi}{8}$ $= 0.322 \text{ cm}^2 \text{ (3 sf)}$

## 2021 Sec 3E EM EOY Paper 2 (Marking Scheme) 80m

No.	Solutions
1(a)	$\frac{4}{(x-5)^2} + \frac{3}{5-x}$ $= \frac{4}{(x-5)^2} - \frac{3}{(x-5)}$ $= \frac{4-3(x-5)}{(x-5)^2}$ $= \frac{4-3x+15}{(x-5)^2}$ $= \frac{19-3x}{(x-5)^2}$
1(b)	$\left(\frac{x^{16}}{36y^6}\right)^{-\frac{1}{2}}$ $= \left(\frac{36y^6}{x^{16}}\right)^{\frac{1}{2}}$ $= \frac{6y^3}{x^8}$
1(c)	$9^k - 1 = 27 \times \sqrt{3^k}$ $3^{2(k-1)} = 3^3 \times 3^{0.5k}$ $3^{2k-2} = 3^{3+0.5k}$ $2k-2 = 3+0.5k$ $1.5k = 5$ $k = 3\frac{1}{3}$

2(a)	$\frac{560}{x}$
2(b)	$\frac{560}{(x-0.3)}$ or $\frac{5600}{10x-3}$
2(c)	$\frac{560}{(x-0.3)} - \frac{560}{x} = 20$ $\frac{560x - 560(x-0.3)}{x(x-0.3)} = 20$ $560x - 560(x-0.3) = 20(x^2 - 0.3x)$ $560x - 560x + 168 = 20x^2 - 6x$ $20x^2 - 6x - 168 = 0 \text{ (Shown)}$
2(d)	$20x^2 - 6x - 168 = 0$ $x = \frac{-(-6) \pm \sqrt{4(20)(-168)}}{2(20)}$ $= \frac{6 \pm \sqrt{13476}}{40}$ $= 3.052154372 \text{ or } -2.752154372$ $= 3.05 \text{ (2d.p.) or } -2.75 \text{ (2d.p.)}$
2(e)	<p>No. of litres of petrol used in April = <math>\frac{560}{3.052154372}</math></p> <p>= 183.4769581</p> <p>= 183 litres (3 s.f.)</p>
3(a)	<p><math>S(10,15)</math> <math>P(-5,-3)</math></p> $\text{Gradient } SP = \frac{15+3}{10+5}$ $= 1\frac{1}{5}$

3(b)	Sub $T(2, -3)$ into $y = \frac{6}{5}x + c$ $-3 = \frac{6}{5}(2) + c$ $c = -5\frac{2}{5} \text{ or } -\frac{27}{5}$ $y = \frac{6}{5}x - 5\frac{2}{5} \text{ or } 5y = 6x - 27$
3(c)	Area of $\Delta PTB = \frac{1}{2} \times \text{Base} \times \text{Height}$ $42 = \frac{1}{2} \times \text{Base} \times 7$ $\text{Base} = 12$ $y = -3 + 12 \text{ or } y = -3 - 12$ $= 9 \qquad \qquad \qquad = -15$
4(a)	$\text{Deceleration} = \frac{80}{10} \qquad \text{or} \qquad \text{Acceleration} = \frac{80 - 0}{30 - 40}$ $= 8\text{m/s}^2 \qquad \qquad \qquad = -8\text{m/s}^2$ $\text{Deceleration} = 8\text{m/s}^2$
4(b)	$(25, 28) (27, y) (30, 80)$ $\frac{y - 28}{27 - 25} = \frac{80 - 28}{30 - 25}$ $\frac{y - 28}{2} = \frac{52}{5}$ $y = \frac{2(52)}{5} + 28$ $y = 48\frac{4}{5}\text{m/s} \text{ or } 48.8\text{ m/s}$

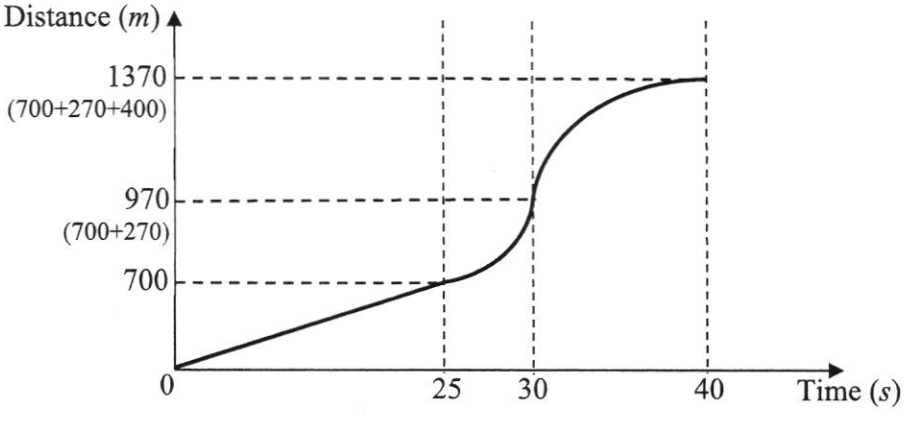
4(c)	<p>Let <math>p</math> be the speed of object B at 30s.</p> $\frac{1}{2} \times 30 \times p = (28 \times 25) + \left( \frac{1}{2} \times (28 + 80) \times 5 \right)$ $15p = 700 + 270$ $15p = 970$ $p = 64\frac{2}{3} \text{ m/s}$
4(d)	
5(a)	$\tan x = \frac{5}{12}$ $x = 0.394791119$ $\angle AOB = 2 \times 0.394791119$ $= 0.789582239$ $= 0.790 \text{ radians (3 s.f.) [Shown]}$

5(b)(i)

$$AO = \sqrt{5^2 + 12^2}$$

$$= 13$$

Area of Segment

= Area of sector  $AOB$  - Area of triangle  $AOB$ 

$$= \frac{1}{2}r^2\theta - \frac{1}{2}ab\sin\theta$$

$$= \left( \frac{1}{2} \times 13^2 \times 0.789582239 \right) - \left( \frac{1}{2} \times 13 \times 13 \times (\sin 0.789582239) \right)$$

$$= 66.71969923 - 60$$

$$= 6.719699229$$

$$= 6.72 \text{ cm}^2 \text{ (3 s.f.)}$$

Or

$$\left( \frac{1}{2} \times 10 \times 12 \right)$$

OR

Area of Segment

= Area of sector  $AOB$  - Area of triangle  $AOB$ 

$$= \frac{1}{2}r^2\theta - \frac{1}{2}ab\sin\theta$$

$$= \left( \frac{1}{2} \times 13^2 \times 0.790 \right) - \left( \frac{1}{2} \times 13 \times 13 \times (\sin 0.790) \right)$$

$$= 66.755 - 60.02485152$$

$$= 6.730148481$$

$$= 6.73 \text{ cm}^2 \text{ (3 s.f.)}$$

OR

	<p>Area of Segment</p> <p>= Area of sector <math>AOB</math> – Area of triangle <math>AOB</math></p> $= \frac{1}{2}r^2\theta - \frac{1}{2}ab\sin\theta$ $= \left(\frac{1}{2} \times 13^2 \times 0.790\right) - \left(\frac{1}{2} \times 10 \times 12\right)$ $= 66.755 - 60$ $= 6.755 \text{ cm}^2$ $= 6.76 \text{ cm}^2 \text{ (3 s.f.)}$
5(b)(ii)	<p>Volume of metal tin</p> <p>= <i>Base Area</i> <math>\times</math> <i>Height</i></p> $= (6.719699229 + 120) \times 28$ $= 3548.151578$ $= 3550 \text{ cm}^3 \text{ (3 s.f.)}$
6(a)	$(AC)^2 = (10)^2 + (10)^2$ $AC = \sqrt{10^2 + 10^2}$ $= \sqrt{200}$ $= 14.14213562$ $= 14.1 \text{ cm (3 s.f.)}$

6(b)(i)	$(AR)^2 = (32)^2 + (\sqrt{200})^2$ $AR = \sqrt{1024 + 200}$ $= \sqrt{1224}$ $r = \frac{\sqrt{\quad}}{2}$ $= 17.49285568$ $= 17.5 \text{ cm (3 s.f.)}$
6(b)(ii)	<p>Volume of the sphere = <math>\frac{4}{3}\pi r^3</math></p> $= \frac{4}{3}\pi(17.49285568)^3$ $= 22421.81418$ $= 22400 \text{ cm}^3 \text{ (3 s.f.)}$
7(a)	$p = 1.7$

7(b)	<p>Graph showing a curve and a line on grid paper. The curve is labeled <math>y = \frac{x^2}{5} + \frac{15}{x} - 8</math>. The line is labeled <math>y = -\frac{1}{2}x + 4</math>.</p>
7(c)	<p>Draw tangent on graph paper.          Gradient = <b>Accept between -3.5 to -2</b></p>
7(d)	$\frac{x^2}{5} + \frac{15}{x} - 8 = 5$ <p><math>y = 5</math> (Draw a horizontal line <math>y=5</math>)</p>



8(b)(ii)	$\frac{\sin \angle PRS}{94} = \frac{\sin 46}{(227.04733\dots)}$ $\sin \angle PRS = 0.29781429$ $\angle PRS = \sin^{-1}(0.29781429)$ $\angle PRS = 17.32637153$ $= 17.3 \text{ (1 d.p.)}$
8(b)(iii)	$\text{Area of } \triangle PQR = \frac{1}{2}(240)(135) \sin 68^\circ$ $= 15020.37844$ $= 15000 \text{ m}^2 \text{ (3 s.f.)}$
8(b)(iv)	$\frac{1}{2}(240)(\text{Height}) = 15020.37844$ $\text{Height} = 125.1698204$ $= 125 \text{ m (3 s.f.)}$ <p style="text-align: center;"><i>Or</i></p> $\sin 68 = \frac{\text{Shortest distance}}{135}$ $\text{Shortest distance} = 135 (\sin 68)$ $= 125.169\dots$ $= 125 \text{ m (3 s.f.)}$
8(c)	$\tan \theta = \frac{42}{125.1698203}$ $\theta = \tan^{-1}\left(\frac{42}{125.1698203}\right)$ $\theta = 18.54887613$ $\theta = 18.5 \text{ (1 d.p.)}$
9(a)	<p>Max amount of vegetables</p> $= 0.35(100)$ $= 35 \text{ kg}$
9(b)	<p>Max amount of meat = <math>2.5(100) + 0.4(100)</math></p> $= 290 \text{ kg}$

9(c)

**Meat**

$$\text{Cost of meat (per kg)} = 290 \times \$5.20 = \$1508$$

$$\text{Cost of meat (min order } \geq 250\text{kg)} = 290 \times \$4.90 = \$1421$$

$$\text{Cost of meat (min order } \geq 400\text{kg)} = 400 \times \$4.70 = \$1880$$

**Vegetables**

$$\text{Cost of veg (per kg)} = 35 \times \$0.80 = \$28$$

$$\text{Cost of veg (min order } \geq 15 \text{ kg)} = 35 \times \$0.70 = \$24.50$$

$$\text{Cost of veg (min order } \geq 25 \text{ kg)} = 35 \times \$0.60 = \$21$$

**Drinks**

$$\text{Total amount of soft drink} = 0.6 \text{ litres} \times 200 = 120 \text{ litres}$$

$$\text{Cost of drinks (per bottle)} = 120 \times \$1.80 = \$216$$

$$\text{Cost of drinks (1 box \& 20 bottles)} = \$120 + (20 \times \$1.80) = \$156$$

**Total cost per person**

$$\text{Total cost per day} = \$1421 + \$21 + \$156 = \$1598$$

$$\text{Total cost per person} = \frac{\$1598}{200} = \$7.99$$

**Total cost per person (with 7% GST)**

$$\text{Total cost per person (with GST)}$$

$$= 1.07 \times \$7.99$$

$$= 8.5493$$

$$= \$8.55 \text{ (2 d.p.)}$$

**Buffet pricing**

$$30\% \rightarrow \$8.5493$$

$$100\% \rightarrow \frac{100}{30} \times 8.5493$$
$$= 28.49766667$$
$$= \$28.50$$

A reasonable amount to charge for a buffet per person will be **at least \$28.50** as Jackie needs to pay utilities, rental, labour cost, marketing and earn profit in order to keep his restaurant running.