

Visit

FREETESTPAPER.com

for more papers



Website: [freetestpaper.com](http://www.freetestpaper.com)



[Facebook.com/freetestpaper](https://www.facebook.com/freetestpaper)



[Twitter.com/freetestpaper](https://www.twitter.com/freetestpaper)



Bukit Batok Secondary School
First Semestral Examination
Secondary Three Express

SCIENCE (PHYSICS, CHEMISTRY)

Paper 1 Multiple Choice

5076/01
12 May 2017
0745 - 0845
1 hour

Additional Materials: Multiple Choice Answer Sheet

READ THESE INSTRUCTIONS FIRST

Write in soft pencil.

Do not use staples, paper clips, glue or correction fluid.

Write your name, index number and class on the Answer Sheet in the spaces provided.

There are **forty** questions on this paper. Answer **all** questions. For each question there are four possible answers **A, B, C** and **D**.

Choose the **one** you consider correct and record your choice in **soft pencil** on the separate Answer Sheet.

Read the instructions on the Answer Sheet very carefully.

Each correct answer will score one mark. A mark will not be deducted for a wrong answer.

Any rough working should be done in this booklet.

A copy of the Data Sheet is printed on page

A copy of the Periodic Table is given at the end of the paper.

The use of an approved scientific calculator is expected, where appropriate.

This document consists of **15** printed pages

Apply past knowledge to new situations

1. The diagram shows a red blood cell and the scale of the diagram.

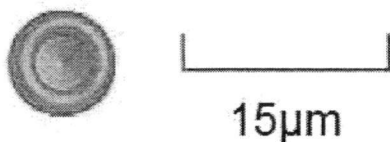

What is the diameter of the red cell in metres?

- A** 3×10^{-6}
B 7.5×10^{-5}
C 3×10^{-5}
D 7.5×10^{-6}
2. During a 100 m race, John broke the school record by completing the run in 11.0 s. Which statement is/are correct in describing John's motion in the race?
- I He ran at a constant speed of 9.1 m/s in the race.
II He ran at a speed higher than 9.1 m/s at some point in the race.
III He ran at a speed lower than 9.1 m/s at some point in the race.
IV He ran at an average speed of 9.1 m/s in the race.
- A** I only
B I and II only
C III and IV only
D II, III and IV only
3. Two objects have the same size and shape but one is heavier than the other. They are each dropped from rest. Comparing the two objects, the heavier object has
- A** the higher initial acceleration and the higher terminal velocity.
B the higher initial acceleration and the same terminal velocity.
C the same initial acceleration and the higher terminal velocity.
D the same initial acceleration and the same terminal velocity.

- 4 A ball is released above the ground at an initial speed of 1.0 m/s. It hit the ground after 4.2 s. What is the speed of the ball just before it hits the ground if air resistance is negligible?

- A 13.0 m/s
 B 14.0 m/s
 C 42.0 m/s
 D 43.0 m/s

- 5 The figure below shows a foot in contact with the ground of a person trying to walk forward to the right. In which direction is the contact force exerted by the foot on the road?

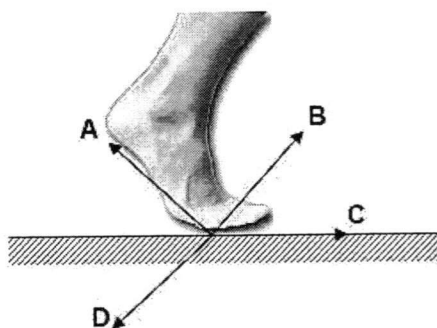

- 6 The figure below shows three forces, F , F_r and F_a , acting on a car that is moving along the road.

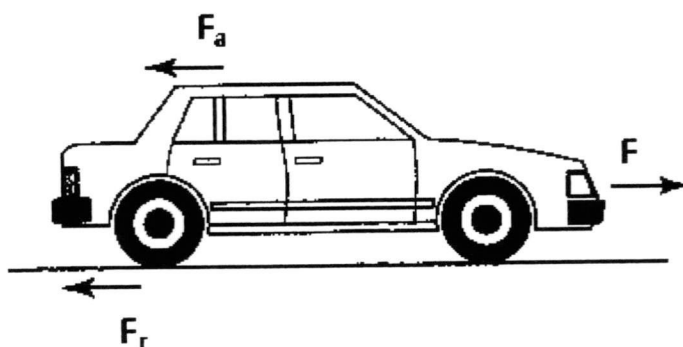

Which combination of forces would result in the car moving forward?

	F_a / N	F_r / N	F / N
A	500	1300	800
B	800	500	1300
C	800	1300	500
D	1300	800	500

Apply past knowledge to new situations

- 7 An astronaut returns from the Moon back to Earth. Which of the following is correct?
- A The astronaut's mass changes as mass depends on gravitational field strength.
 - B The astronaut's weight changes as weight depends on gravitational field strength.
 - C The astronaut's mass does not change as mass depends on gravitational field strength.
 - D The astronaut's weight does not change as weight depends on gravitational field strength.
- 8 The mass of an object is 800 g. What is its weight on Earth? (Take gravitational field strength on Earth = 10N/kg)
- A 8.0 N
 - B 80 N
 - C 800 N
 - D 8000 N

- 9 A measuring cylinder filled with 40 cm³ of water had a mass of 50 g. Ten identical marbles were dropped into the measuring cylinder. The level of the water rose to the 60 cm³ mark. The total mass of the measuring cylinder and its contents increased to 300 g.

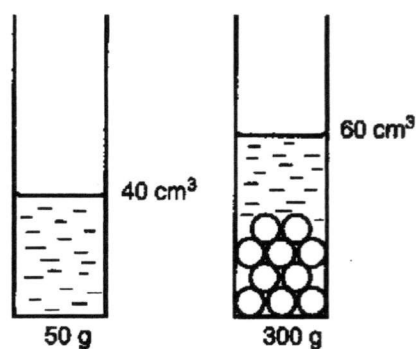

What is the density of marble?

- A 1.25 g/cm³
- B 5.0 g/cm³
- C 7.5 g/cm³
- D 12.5 g/cm³

10 The diagram shows a beaker containing three liquids which do not mix.

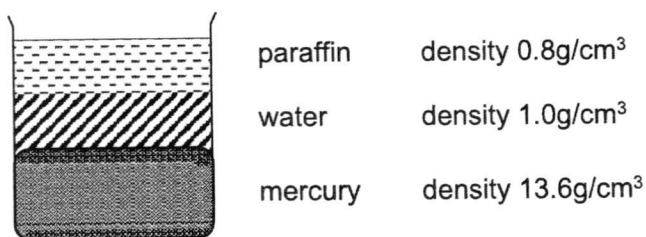

A small lead block () is carefully dropped into the beaker. Density of lead is 9.36g/cm^3 . Which diagram shows the final position of the lead block?

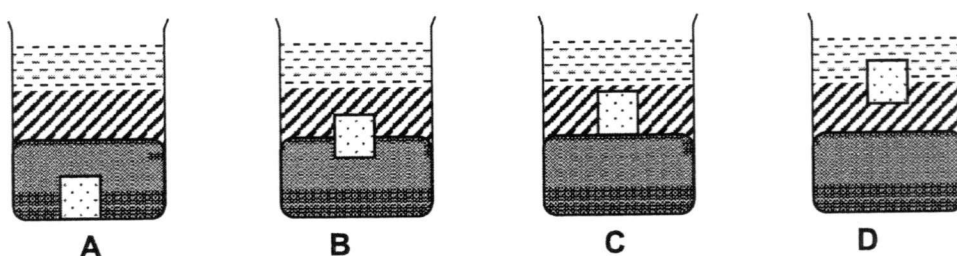

11 To prevent a cement mixer from sinking into soft ground, the mixer is placed on a large flat board.

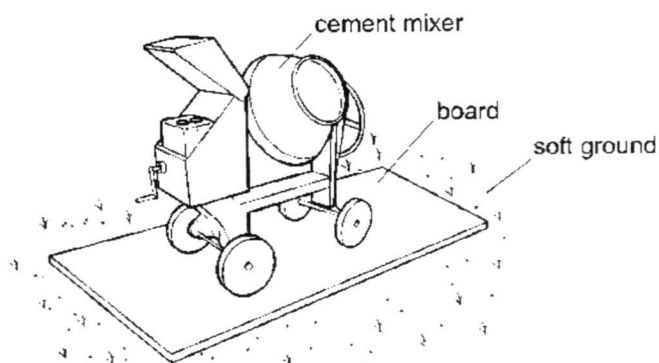

Why does this prevent the mixer from sinking?

- A** The large area decreases the density of the cement mixer.
- B** The large area decreases the force acting on the ground.
- C** The large area decreases the pressure on the ground.
- D** The large area decreases the weight of the cement mixer.

- 12** A dune buggy has a sail of area 0.06 m^2 as shown in the diagram below. The wind exerts a pressure of 500 Pa on the sail.

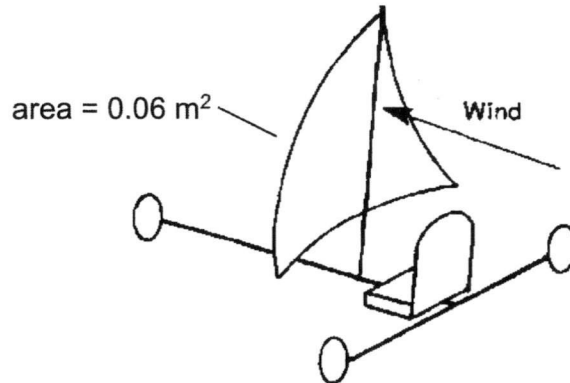

What is the force acting on the sail?

- A** 30 N
B 83 N
C 120 N
D 830 N
- 13** Which of the following is not an example of work done?
- A** Carrying a stack of books
B Pushing a cart of books
C Sliding a book across a rough floor
D Throwing a book vertically
- 14** A car decelerates while travelling down a hill.
 Which of the following changes is true?

	gravitational potential energy	kinetic energy
A	increase	increase
B	increase	decrease
C	decrease	increase
D	decrease	decrease

- 15 A person exerts a horizontal force 600 N on a box that also experiences a friction force of 200 N. If it takes 4.0 seconds to move the box 3.0 m, what is the average useful power?
- A 150W
 - B 300W
 - C 450W
 - D 600 W
- 16 In terms of the simple kinetic theory of matter, why does temperature decrease as a liquid cools?
- A The average spacing between the molecules becomes smaller.
 - B The interaction between the molecules becomes weaker.
 - C The average speed of the molecules decreases.
 - D The collision rate of molecules decreases.
- 17 A substance consists of particles that are close together and sliding past one another at random. The average speed of the particles is gradually increasing and the particles are gradually getting further apart. Which of the following **best** describes the substance?
- A A gas being cooled
 - B A solid being heated
 - C A liquid being cooled
 - D A liquid being heated
- 18 When a person stands on bare feet with one foot on a marble floor and the other foot on a cotton floor mat, the marble floor feels colder than the cotton floor mat. What is the **most** likely explanation for this phenomena?
- A Air is unable to circulate through the cotton floor mat fibres
 - B The marble floor is at a lower temperature than the cotton floor mat
 - C More energy flows from his foot to the marble floor than to the cotton floor mat
 - D More energy flows from the cotton floor mat to his foot than from the marble floor to his foot

- 19 A block of ice is heated until it melts. The water produced is heated until it boils.

What row correctly states what happens to the temperature of the ice while melting, and the temperature of the water while boiling?

	temperature of ice while melting	temperature of water while boiling
A	increases	increases
B	increases	stays the same
C	stays the same	increases
D	stays the same	stays the same

- 20 A waxy solid is melted in a boiling tube and then allowed to cool at room temperature. The graph shows the cooling curve.

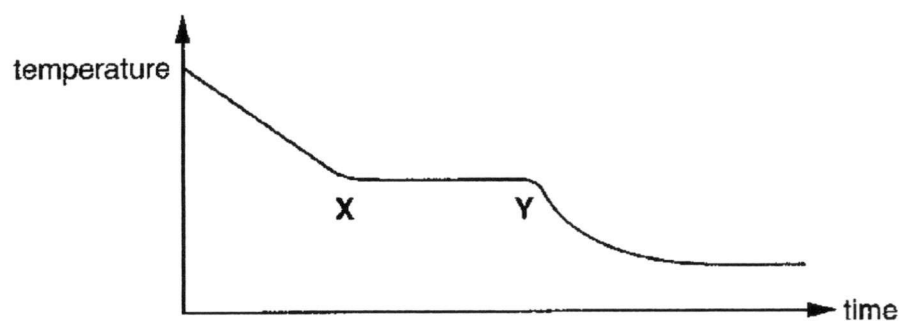

What is happening between points X and Y?

- A** liquid is cooling
- B** liquid is turning to solid
- C** solid is cooling
- D** solid has stopped cooling

Name: Index No. Class:



Bukit Batok Secondary School
First Semestral Examination
Secondary Three Express

SCIENCE (PHYSICS, CHEMISTRY)

Paper 2 Physics

5076/02

5th May 2017

0745 - 0900

1 hour 15 minutes

Candidates answer on the Question Paper.
 No Additional Materials are required.

READ THESE INSTRUCTIONS FIRST

Write your name, index number and class in the spaces provided at the top of this page.

You may use an HB pencil for any diagrams, graphs, tables or rough working.

Write in dark blue or black pen.

Do not use staples, paper clips, highlighters, glue or correction fluid.

The use of an approved scientific calculator is expected, where appropriate.

You may lose marks if you do not show your working or if you do not use appropriate units.

Section A

Answer **all** questions in the spaces provided.

Write your answers in the spaces provided on the question paper.

Section B

Answer any **two** questions.

Write your answers in the spaces provided on the question paper.

At the end of the examination, fasten all your work securely together.

The number of marks is given in brackets [] at the end of each question or part question.

For Examiner's Use	
Section A	
Section B	
Total	

This document consists of **15** printed pages.

Apply past knowledge to new situations

Section A

Answer **all** questions. Write your answers in the spaces provided.

1 Quantities can be categorise into two groups, scalars and vectors.

(a) State the difference between a scalar quantity and a vector quantity.

.....
.....[1]

(b) A cyclist makes a turn at constant speed.

(i) Explain why the cyclist accelerates even though the cyclist's speed remains constant during the turn.

.....
.....
..... [2]

(ii) Select any two of the following terms that are scalar quantities.

mass, force, weight, temperature, power,
acceleration, displacement, volume, distance

.....[2]

2 (a) Complete the following sentences.

(i) 780 ng is equal to g

(ii) 360 kV is equal to V

[2]

- (b) The formula for converting temperature from the Celsius scale to the Fahrenheit scale is given below.

$$T_{(^{\circ}\text{F})} = T_{(^{\circ}\text{C})} \times 1.8 + 32$$

Where $T_{(^{\circ}\text{C})}$ is the temperature measured in Celsius and
 $T_{(^{\circ}\text{F})}$ is the temperature measured in Fahrenheit.

The typical temperature during spring in Washington DC is 71 Fahrenheit.
What would be the temperature in Celsius?

temperature = $^{\circ}\text{C}$ [2]

- 3 A car of mass 1000 kg was accelerated from rest to a speed of 20 m/s in 10 seconds. Assuming the acceleration of the car to be constant, calculate the force that caused the acceleration.

force = N [2]

- 4 A person winds some thread tightly 4 times round the length of a metre rule and cuts the ends off level with the left-hand end of the rule, as shown in the figure below.

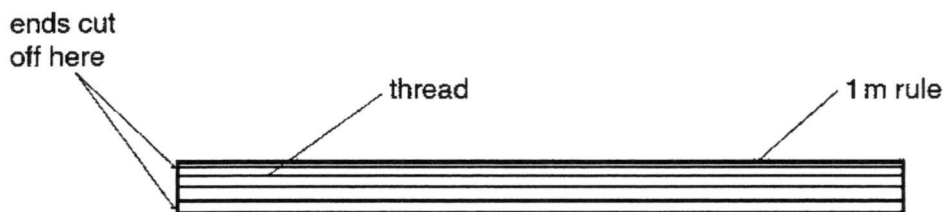

- (a) Write down the length of the thread, giving your answer to the nearest metre.

length = m [1]

- (b) Is the actual length of thread slightly greater, equal to or slightly less than your answer to (a)? Give your reason.

.....
 [2]

- (c) A micrometer is used to measure the diameter of the wire.
 With the jaws closed with no wire, the micrometer reading is shown in diagram 1.
 With the jaws closed around the wire, the micrometer reading is shown in diagram 2.

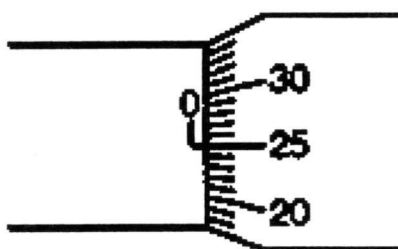

diagram 1

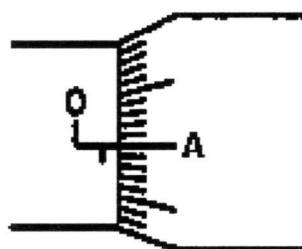
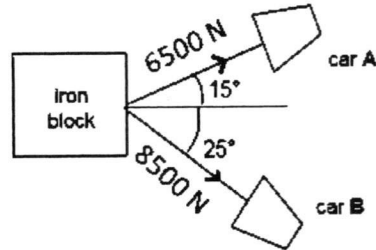

diagram 2

The diameter of the wire is 0.60 mm. What should be the marking at A in diagram 2?

marking : [2]

- 5 The figure below shows a rectangular iron block being pulled by two cars on a rough surface. Car A is pulling with a force of 6500 N and car B is pulling with a force of 8500 N.



- (a) By means of a scale drawing, find the resultant force experienced by the iron block.

resultant force =N [3]

- (b) The iron block is found to travel at a constant speed in a fixed direction.
 (i) Calculate the size of the frictional force experience by the iron block.

size of frictional force =N [1]

- (ii) In your scale drawing, draw a vector to represent the frictional force calculated in (b)(i). [1]

- 6 The table below shows the gravitational field strength of a few planets in the Solar system.

planet	gravitational field strength / N kg^{-1}
Earth	9.8
Jupiter	25.0
Mars	3.8
Neptune	13.8
Uranus	10.4
Venus	8.8

- (a) "Venus has a gravitational field strength of 8.8 N/kg ."
Explain what is meant by this statement.

.....

..... [1]

- (b) State the formula that relates the mass of an object to its weight. On which planet will a 2.0 kg mass weigh the heaviest? Calculate that weight.

planet =weight = N[3]

- (c) State and explain what happens to the density of the book when it is brought from the Earth to Neptune.

.....

..... [2]

- 7 A double-decker bus is travelling on a tilted road as shown in the figure below. The weight of the bus acts through the centre of gravity, CG, of the bus.

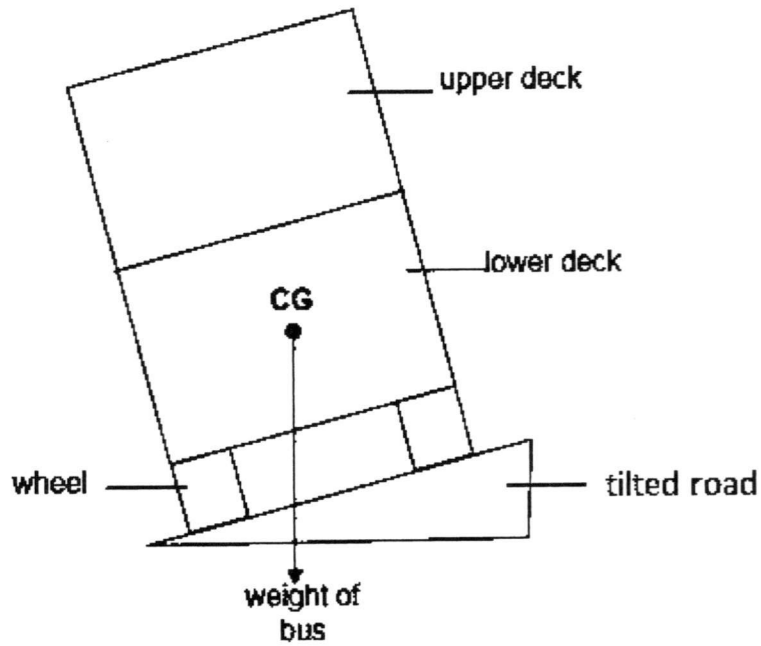

- (a) Explain whether the bus will topple over.

.....
.....
.....[2]

- (b) Passengers are not allowed to stand on the upper deck of the bus. Explain the reason for this rule.

.....
.....
.....[2]

- 8 A uniform marble slab is placed on a table top as shown in the figure below

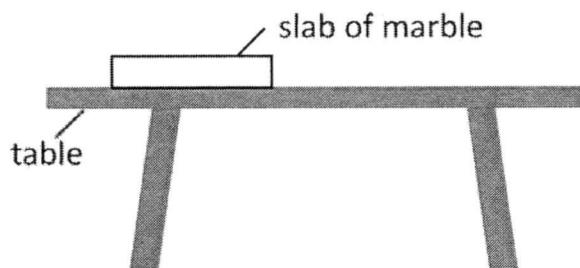

Read each of the following statements carefully and state using "T" if it is true or "F" if it is false. Explain your answer.

- (a) The pressure exerted by the marble slab on the table depends on the object's weight and the area of the table

.....
.....[1]

- (b) If the slab of marble is broken into two pieces of different sizes, the pressure exerted on the table by the smaller piece on the table top will be smaller than the pressure exerted on the same table top by the bigger piece of marble.

.....
.....[1]

- 9 The figure below shows the side view of a playground ride. The vehicle of mass 150 kg starts from rest at point **A** at the top of the smooth curved track. The vehicle then rolls down the track passing through point **X**. It then slows down as it travels horizontally through a trough containing water, coming to rest at point **B**.

mass of vehicle = 150 kg

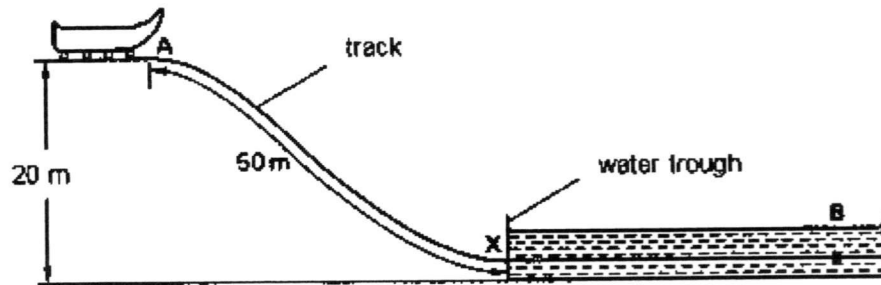

- (a) Describe the main energy conversions, which take place as the vehicle moves from point **A** to **B**.

point **A** to **X**:

.....

point **X** to **B**:

.....[2]

- (b) As the vehicle moves from point **A** to point **X**, it travels 50 m along the track and falls through a vertical height of 20 m. Assuming that the effects of friction can be ignored along the track, calculate

- (i) the loss in gravitational potential energy of the vehicle,

gravitational potential energy = J [1]

- (ii) the speed of the vehicle when it reaches point **X**.

speed =m/s [2]

10 A glass conical flask contains air at room temperature. It is heated by a flame as shown in the figure below.

The flask is sealed, at room temperature, by means of an ink drop in a narrow glass tube.

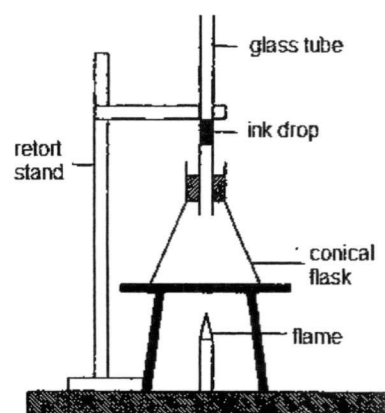

(a) State and explain any change that occurs in the motion of the air molecules in the conical flask as it is heated.

.....

 [2]

(b) Suggest and explain what will happen to the ink drop in the flask.

.....

 [2]

11 Evaporation and boiling are two processes which are similar yet different.

(a) State one similarity between evaporation and boiling

.....[1]

(b) Explain the following difference between evaporation and boiling. "Boiling occurs throughout the liquid while evaporation takes place only from the exposed surface of the liquid".

.....

 [2]

Section BAnswer any **two** questions.

Write your answers in the spaces provided.

- 12 Fig 12.1 below shows the velocity-time graph of two cars which started from the same point.

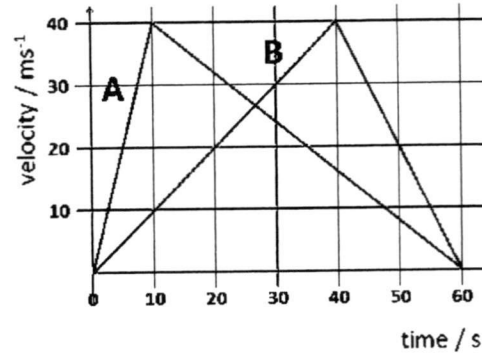

Fig 12.1

- (a) Explain what is meant by uniform acceleration.

.....

.....

..... [1]

- (b) Calculate the acceleration of car A during the first 10 seconds.

acceleration = [2]

- (c) Calculate the average speed of car A throughout the journey.

average speed = [2]

(d) In Fig 12.2 and 12.3 below, sketch the acceleration-time graph and the displacement-time graph of B

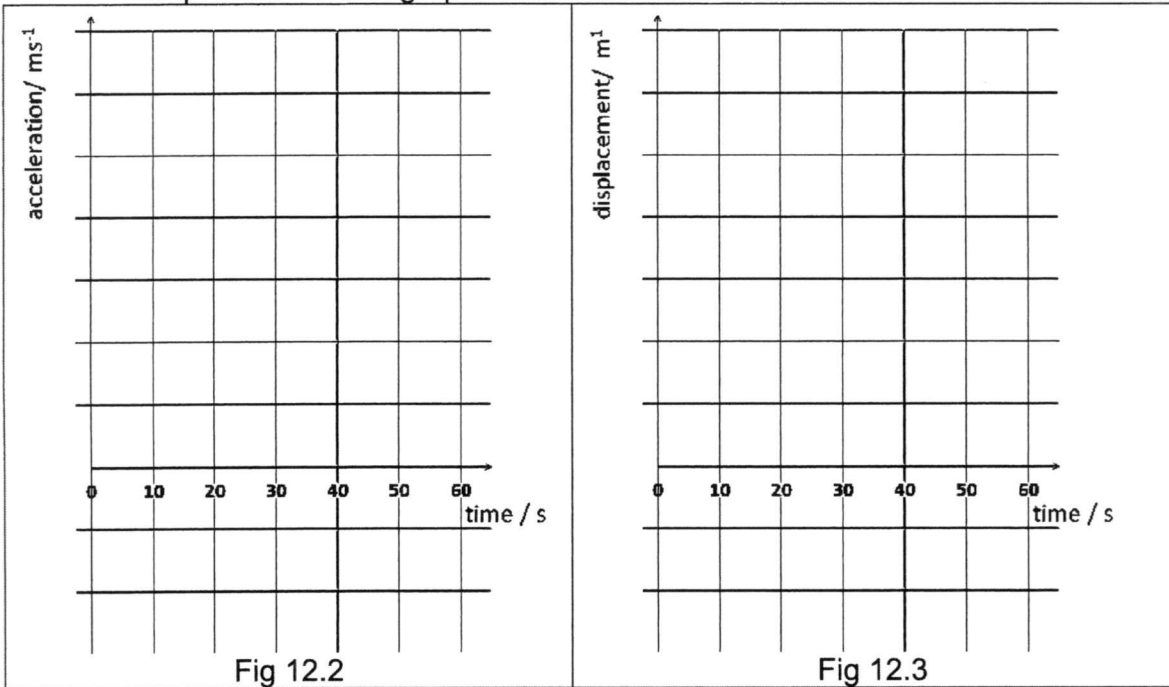

[3]

(e) A student says that both cars are travelling in the same direction. Do you agree with him? Explain.

.....
 [1]

(f) Did the two cars end at the same point. Explain.

.....
 [1]

- 13 A uniform metre rule is balanced at the 50 cm mark. Loads of 1.5 N and 3.0 N are hung from the 10 cm and 40 cm marks respectively, as shown in the figure below. A weight W hanging from the 80 cm mark balances the system.

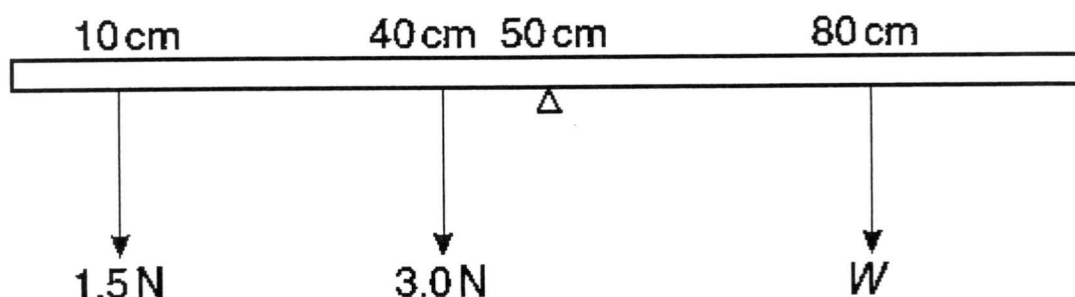

- (a) State the Principle of Moments.

.....

 [2]

- (b) Calculate the total moment of the 1.5 N and 3.0 N loads about the pivot.
 State the direction of rotation

moment = direction of rotation = [2]

- (c) Using the principle of moments, calculate the value of the weight W .

weight = [2]

(d) State and explain what will happen to the metre rule if weight W is shifted to the 90 cm mark.

.....
.....[2]

(e) On the figure, indicate the centre of gravity of the metre rule with a 'X' and explain why is the weight of the metre rule not considered in the calculation in (c).

.....
.....[2]

14 In the cooling system of an engine, fins made of metal are attached to the engine as shown in the figure below. Thermal energy is transferred away from the engine by conduction, convection and radiation.

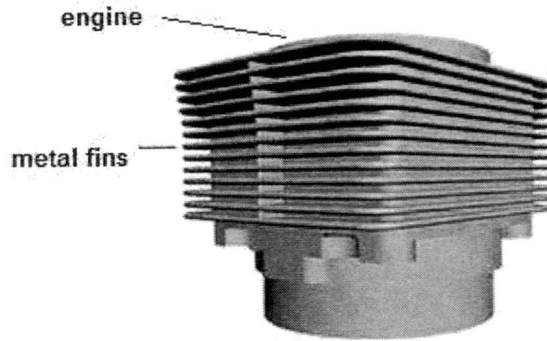

(a) State **one** similarity and **one** difference between conduction and convection.

.....

.....

..... [2]

(b) Use ideas of thermal energy transfer to explain how the following features help to cool the engine.

(i) fins are made of metal

.....

..... [2]

(ii) fins have large surface area

.....

..... [2]

(iii) fins have spacing between them

.....

..... [2]

(c) A student suggests that an additional feature to cool down the engine is to keep the fins wet at all times by spraying water on them. Do you think this will increase the cooling rate? Explain your answer.

.....

..... [2]

END OF PAPER



Bukit Batok Secondary School
First Semestral Examination
Secondary Three Express

SCIENCE (PHYSICS, CHEMISTRY)

Paper 1 Multiple Choice

5076/01

11 May 2017

0745 - 0845

1 hour

Additional Materials: Multiple Choice Answer Sheet

READ THESE INSTRUCTIONS FIRST

Do not use staples, paper clips, glue or correction fluid.

Write your name, index number and class on the Answer Sheet in the spaces provided.

There are **forty** questions on this paper. Answer **all** questions. For each question there are four possible answers **A, B, C** and **D**.

Choose the **one** you consider correct and record your choice in **soft pencil** on the separate Answer Sheet.

Read the instructions on the Answer Sheet very carefully.

Each correct answer will score one mark. A mark will not be deducted for a wrong answer.

Any rough working should be done in this booklet.

A copy of the Data Sheet is printed on page

A copy of the Periodic Table is given at the end of the paper.

The use of an approved scientific calculator is expected, where appropriate.

PERSIST!

- 1 The diagram shows a red blood cell.

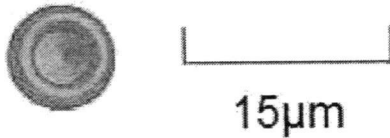

What is the diameter of the red cell in metres?

- A 3×10^{-6}
- B 7.5×10^{-5}
- C 3×10^{-5}
- D 7.5×10^{-6}

- | |
|---|
| <ol style="list-style-type: none"> 1. D; Diameter is about half the scale 2. D; Average speed is 9.1m/s. (I) is not possible because the runner starts with 0m/s 3. D; principle of free fall 4. D; change in $v = 42\text{m/s}$. Need to add 1m/s |
|---|

- 2 During a 100 m race, John broke the school record by completing the run in 11.0 s. Which statement is/are correct in describing John's motion in the race?

- I He ran at a constant speed of 9.1 m/s in the race.
- II He ran at a speed higher than 9.1 m/s at some point in the race.
- III He ran at a speed lower than 9.1 m/s at some point in the race.
- IV He ran at an average speed of 9.1 m/s in the race.

- A I only
- B I and II only
- C III and IV only
- D II, III and IV only

- 3 Two objects have the same size and shape but one is heavier than the other. They are each dropped from rest. Comparing the two objects, the heavier object has

- A the higher initial acceleration and the higher terminal velocity.
- B the higher initial acceleration and the same terminal velocity.
- C the same initial acceleration and the higher terminal velocity.
- D the same initial acceleration and the same terminal velocity.

- 4 A ball is released above the ground at an initial speed of 1.0 m/s. It hit the ground after 4.2 s. What is the speed of the ball just before it hits the ground if air resistance is negligible?

- A 13.0 m/s
- B 14.0 m/s
- C 42.0 m/s
- D 43.0 m/s

- 5 The figure below shows a foot in contact with the ground of a person trying to walk forward to the right. In which direction is the contact force exerted by the foot on the road?

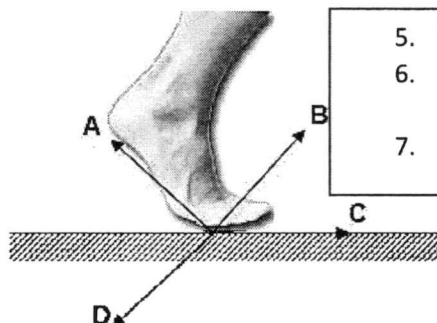

5. D
6. B. Forces need to balance to move forward
7. B

- 6 The figure below shows three forces, F , F_r and F_a , acting on a car that is moving along the road.

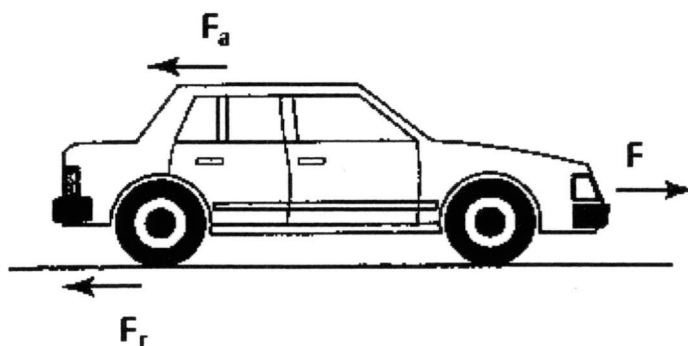

Which combination of forces would result in the car moving forward?

	F_a / N	F_r / N	F / N
A	500	1300	800
B	800	500	1300
C	800	1300	500
D	1300	800	500

- 7 An astronaut returns from the Moon back to Earth. Which of the following is correct?
- A** The astronaut's mass changes as mass depends on gravitational field strength.
- B** The astronaut's weight changes as weight depends on gravitational field strength.
- C** The astronaut's mass does not change as mass depends on gravitational field strength.
- D** The astronaut's weight does not change as weight depends on gravitational field strength.

8 The mass of an object is 800 g. What is its weight on Earth? (Take gravitational field strength on Earth = 10N/kg)

- A 8.0 N
- B 80 N
- C 800 N
- D 8000 N

8. A ; 0.8×10 (convert to kg)
 9. D; Mass = 250g, Volume = 20cm^3
 10. B

9 A measuring cylinder filled with 40 cm^3 of water had a mass of 50 g. Ten identical marbles were dropped into the measuring cylinder. The level of the water rose to the 60 cm^3 mark. The total mass of the measuring cylinder and its contents increased to 300 g.

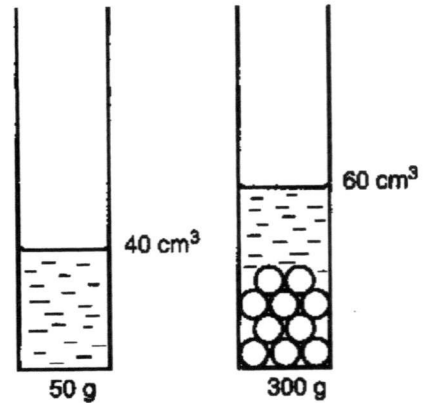

What is the density of marble?

- A 1.25 g / cm^3
- B 5.0 g / cm^3
- C 7.5 g / cm^3
- D 12.5 g / cm^3

10 The diagram shows a beaker containing three liquids which do not mix.

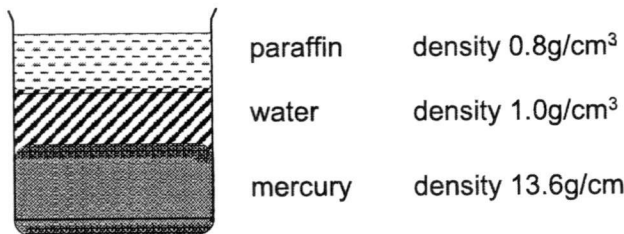

A small lead block (shown in a small square icon) is carefully dropped into the beaker. Density of lead is 9.36 g/cm^3 . Which diagram shows the final position of the lead block?

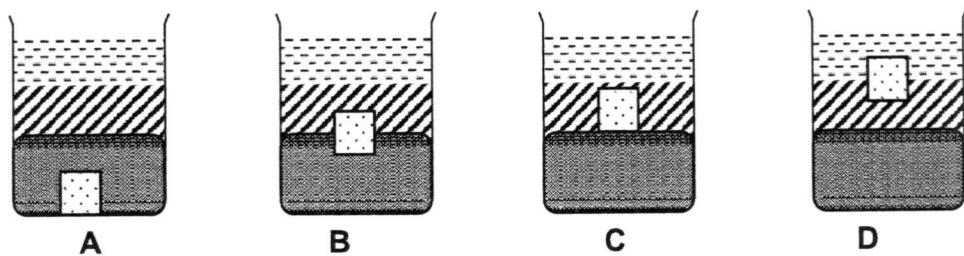

- 11 To prevent a cement mixer from sinking into soft ground, the mixer is placed on a large flat board.

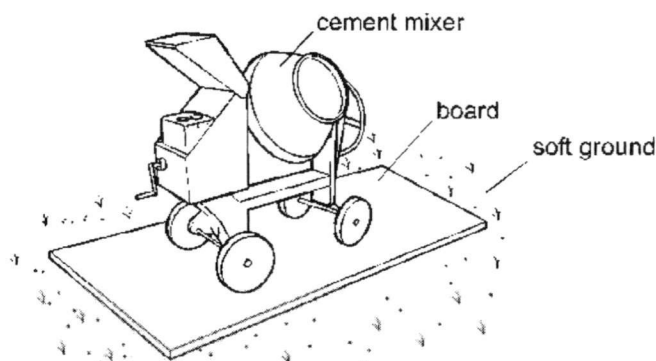

Why does this prevent the mixer from sinking?

- A The large area decreases the density of the cement mixer.
 - B The large area decreases the force acting on the ground.
 - C The large area decreases the pressure on the ground.
 - D The large area decreases the weight of the cement mixer.
- 12 A dune buggy has a sail of area 0.06 m^2 as shown in the diagram below. The wind exerts a pressure of 500 Pa on the sail.

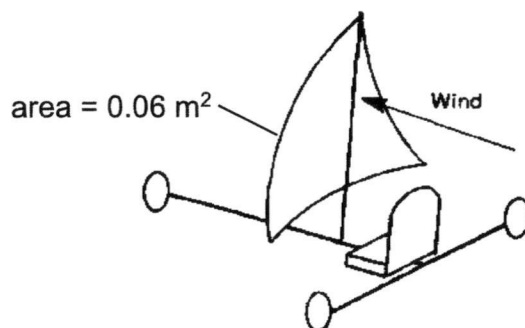

What is the force acting on the sail?

- A 30 N
- B 83 N
- C 120 N
- D 830 N

11. C
 12. A; $500 = F/0.06$
 13. A; Carrying books does not move the books in the direction of the force.

- 13 Which of the following is not an example of work done?
- A Carrying a stack of books
 - B Pushing a cart of books
 - C Sliding a book across a rough floor
 - D Throwing a book vertically

14 A car decelerates while travelling down a hill.

Which of the following changes is true?

	gravitational potential energy	kinetic energy
A	increase	increase
B	increase	decrease
C	decrease	increase
D	decrease	decrease

15 A person exerts a horizontal force 600 N on a box that also experiences a friction force of 200 N. If it takes 4.0 seconds to move the box 3.0 m, what is the average useful power?

- A** 150W
- B** 300W
- C** 450W
- D** 600 W

- 14. D
- 15. B; $(400 \times 3) / 4$
- 16. C
- 17. D
- 18. C. The mat and marble are in the same place so assume same temp

16 In terms of the simple kinetic theory of matter, why does temperature decrease as a liquid cools?

- A** The average spacing between the molecules becomes
- B** The interaction between the molecules becomes weaker.
- C** The average speed of the molecules decreases.
- D** The collision rate of molecules decreases.

17 A substance consists of particles that are close together and sliding past one another at random. The average speed of the particles is gradually increasing and the particles are gradually getting further apart.

Which of the following **best** describes the substance?

- A** A gas being cooled
- B** A solid being heated
- C** A liquid being cooled
- D** A liquid being heated

18 When a person stands on bare feet with one foot on a marble floor and the other foot on a cotton floor mat, the marble floor feels colder than the cotton floor mat. What is the **most** likely explanation for this phenomena?

- A** Air is unable to circulate through the cotton floor mat fibres
- B** The marble floor is at a lower temperature than the cotton floor mat
- C** More energy flows from his foot to the marble floor than to the cotton floor mat
- D** More energy flows from the cotton floor mat to his foot than from the marble floor to his foot

- 19** A block of ice is heated until it melts. The water produced is heated until it boils.
What row correctly states what happens to the temperature of the ice while melting, and the temperature of the water while boiling?

	temperature of ice while melting	temperature of water while boiling
A	increases	increases
B	increases	stays the same
C	stays the same	increases
D	stays the same	stays the same

19. D
20. CB

- 20** A waxy solid is melted in a boiling tube and then allowed to cool at room temperature. The graph shows the cooling curve.

What is happening between points X and Y?

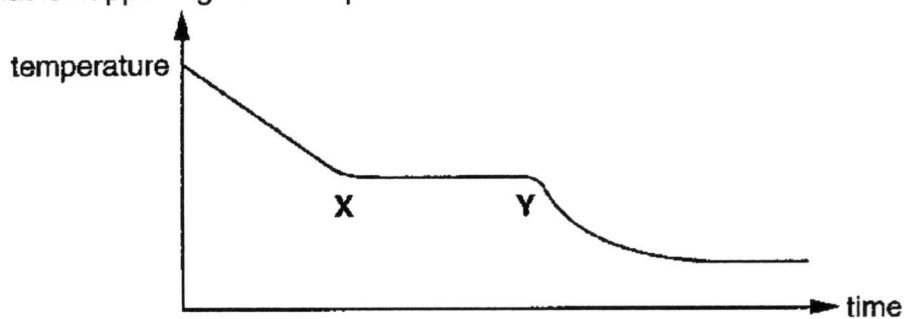

- A** liquid is cooling
B liquid is turning to solid
C solid is cooling
D solid has stopped cooling

Name: Index No. Class:



Bukit Batok Secondary School
First Semestral Examination
Secondary Three Express

SCIENCE (PHYSICS, CHEMISTRY)

Paper 2 Physics

5076/02**5th May 2017****0745 - 09****1 hour 15 minutes**

Candidates answer on the Question Paper.
 No Additional Materials are required.

READ THESE INSTRUCTIONS FIRST

Write your name, index number and class in the spaces provided at the top of this page.
 You may use an HB pencil for any diagrams, graphs, tables or rough working...

Do not use staples, paper clips, highlighters, glue or correction fluid.

The use of an approved scientific calculator is expected, where appropriate.
 You may lose marks if you do not show your working or if you do not use appropriate units.

Section A

Answer **all** questions in the spaces provided.
 Write your answers in the spaces provided on the question paper.

Section B

Answer any **two** questions.
 Write your answers in the spaces provided on the question paper.

At the end of the examination, fasten all your work securely together.
 The number of marks is given in brackets [] at the end of each question or part question.

For Examiner's Use	
Section A	
Section B	
Total	

PERSIST!

Section A

Answer **all** questions. Write your answers in the spaces provided.

1 Quantities can be categorise into two groups, scalar and vector.

(a) State the difference between a scalar quantity and a vector quantity.

.....
[1]

(b) A cyclist makes a turn at constant speed.

(i) Explain why the cyclist's accelerates even though the cyclist's speed remains constant during the turn.

(a) Scalar quantity doesn't include direction but vector quantity does. [1] (i) velocity is a vector quantity [1], in turning direction change [1] so velocity change. (ii) mass, temperature, volume, distance, power [any 3 2m, any 2 1m]
---	-------------------------

[2]

(ii) Select any three of the following terms that are scalar quantities.

Mass, force, weight, temperature, power,
 acceleration, displacement, volume, distance

.....[2]

2 (a) Complete the following sentences.

(i) 780 ng is equal to g

0.000 000 78 [1] 360 000 [1]

(ii) 360 kV is equal to V

[2]

- (b) The formula for converting temperature from the Celsius scale to the Fahrenheit scale is given below.

$$T_{(^{\circ}\text{F})} = T_{(^{\circ}\text{C})} \times 1.8 + 32$$

Where $T_{(^{\circ}\text{C})}$ is the temperature measured in Celsius and
 $T_{(^{\circ}\text{F})}$ is the temperature measured in Fahrenheit.

The typical temperature in spring in Washington DC is 71 Fahrenheit.
 What would be the temperature in Celsius?

$$71 = T \times 1.8 + 32$$

$$T = 21.7 \text{ [M1][A1 1 dp]}$$

temperature = $^{\circ}\text{C}$ [2]

- 3 A car of mass 1000 kg was accelerated from rest to a speed of 20 m/s in 10 seconds. Assuming the acceleration of the car to be constant, calculate force that caused the acceleration.

$$a = 20 / 10 = 2 \text{ m/s}$$

$$F = ma = 1000 \times 2 = 2000 \text{ N [1]}$$

For method mark....

a x but answer ✓ [1]

a ✓ answer method x [0]

force = N [2]

- 4 A person winds some wires tightly 4 times round the length of a metre rule and cuts the ends off level with the left-hand end of the rule, as shown in the figure below.

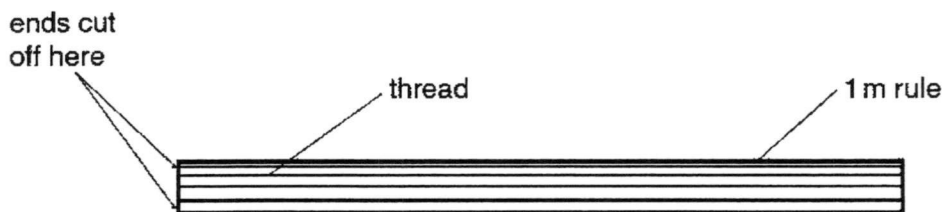

- (a) Write down the length of the thread, giving your answer to the nearest metre.

length = m [1]

- (b) Is the actual length of thread slightly greater, equal to or slightly less than your answer to (a)? Give your reason.

.....
 [2]

- (c) A micrometer is used to measure the diameter of the wire. With the jaws closed with no wire, the micrometer reading is shown in diagram 1. With the jaws closed around the glass sheet, the micrometer reading is shown in diagram 2.

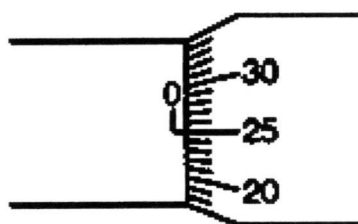

diagram 1

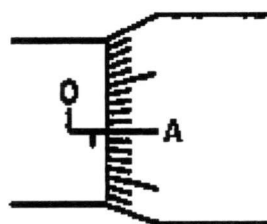

diagram 2

The diameter of the wire is 0.6 mm. What should be the marking at A in diagram 2?

- (a) 8 [1]
- (b) Will be slightly greater [1] because when wrapping the ruler, the thickness of the ruler is included [1]
 Also accept that the ends are sticking out [1]
- (c) $0.6 + 0.25 = 0.85$ [1]. Marking should be 35 [1]

marking : [2]

- 5 The figure below shows a rectangular iron block being pulled by two cars on a rough surface. Car A is pulling with a force of 6500 N and car B is pulling with a force of 8500 N.

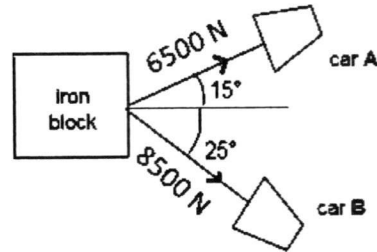

- (a) By means of a scale drawing, find the resultant force experienced by the iron block.

- (a)
 (b) Ecf same is (a)
 (c)

resultant force =N [3]

- (b) The iron block is found to travel at a constant speed in a fixed direction.
 (i) Calculate the size of the frictional force experience by the iron block.

size of frictional force =N [1]

(ii) In your scale drawing, draw a vector to represent the frictional force calculated in (b)(i). [1]

6 The table below shows the gravitational field strength of a few planets in the Solar system.

planet	gravitational field strength / N kg ⁻¹
Earth	9.8
Jupiter	25.0
Mars	3.8
Neptune	13.8
Uranus	10.4
Venus	8.8

(a) "Venus has a gravitational field strength of 8.8 N/kg." Explain what is meant by this statement.

(a) 1 kg of mass will have 8.8 N of weight [1]
 (b) $W = mg$ [1], Jupiter[1], $W = 25 \times 2 = 50 \text{ N}$ [1]
 (c) No change because mass don't change [2]

.....
 [1]

(b) State the formula that relates the mass of an object to its weight. On which planet will a 2.0 kg mass weigh the heaviest? Calculate that weight.

Planet =weight = N[3]

(c) State and explain what happens to the density of the book when it is brought from the Earth to Neptune.

.....
 [2]

- 7 A double-decker bus is travelling on a tilted road as shown in the figure below. The weight of the bus acts through the centre of gravity, CG, of the bus.

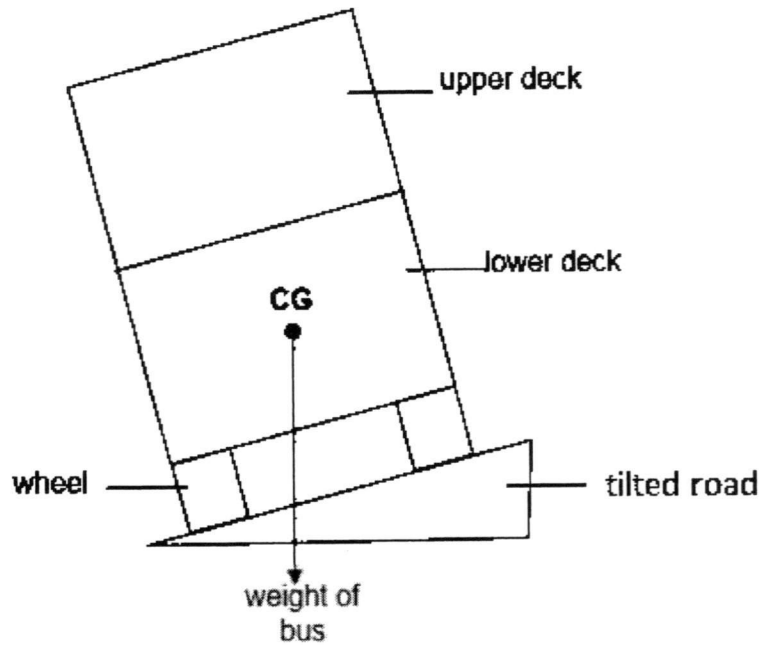

- (a) Explain whether the bus will topple over.

.....

[2]

- (b) Passengers are not allowed to stand on the upper deck of the bus. Explain the reason for this rule.

(a) The bus will not topple because the CG which supplies the clockwise moments is balanced [1] by the anti clockwise moments supplied by the wheel at the higher side of the ramp.[1]
 OR line of action of CG through the base[2]
 OR CG is lower [2]
 *If student write weight is acting through the base of the bus only give 1m

(b) By standing at upper deck, the CG will be moved upwards [1], this will cause the line of action to move to such a place where the CG will cause a anti clockwise moment that will cause the bus to topple over [1].

.....
[2]

- 8 A uniform marble slab is placed on a table top as shown in the figure below

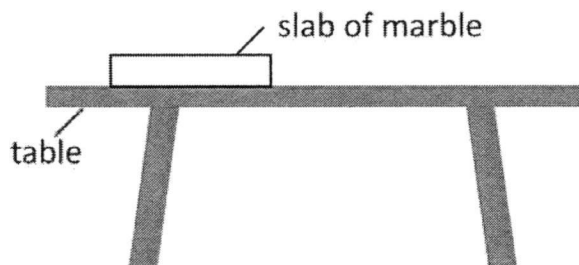

Read each of the following statements carefully and state using "T" if it is true or "F" if it is false. Explain your answer.

- (a) The pressure exerted by the marble slab on the table depends on the object's weight and the area of the table

.....
[1]

- (b) If the slab of marble is broken into two pieces of different sizes, the pressure exerted on the table by the smaller piece on the table top will be smaller than the pressure exerted on the same table top by the bigger piece of marble.

.....
[1]

(a) F, the pressure exerted is depend t on the AREA OF THE SLAB or AREA OF THE CONTACT AREA. [1]

(b) F , the area of contact is reduced but the weight is reduced proportionately so the pressure should be the same [1]

- 9 The figure below shows the side view of a playground ride. The vehicle of mass 150 kg starts from rest at point **A** at the top of the smooth curved track. The vehicle then rolls down the track passing through point **X**. It then slows down as it travels horizontally through a trough containing water, coming to rest at point **B**.

mass of vehicle = 150 kg

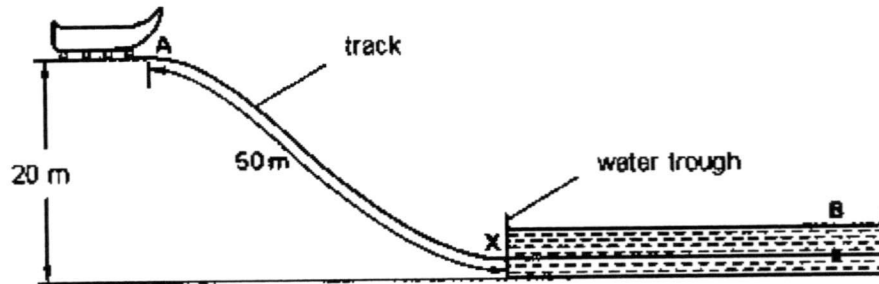

- (a) Describe the main energy conversions, which take place as the vehicle moves from point **A** to **B**.

point **A** to **X**:

.....

point **X** to **B**:

.....[2]

- (b) As the vehicle moves from point **A** to point **X**, it travels 50 m along the track and falls through a vertical height of 20 m. Assuming that the effects of friction can be ignored along the track, calculate

- (i) the loss in gravitational potential energy of the vehicle,

gravitational potential energy = J [1]

- (ii) the speed of the vehicle when it reaches point **X**.

(a) GPE → KE [1] ; KE → sound energy / heat [1]

(b) (i) $GPE = mgh = 150 \times 10 \times 20 = 30\,000 \text{ J}$ [1]

(ii) $30,000 = \frac{1}{2} \times m \times v^2$ [1] → $v = 20 \text{ m/s}$ [1]

speed =m/s [2]

10 A glass conical flask contains air at room temperature. It is heated by a flame as shown in the figure below.

The flask is sealed, at room temperature, by means of an ink drop in a narrow glass tube.

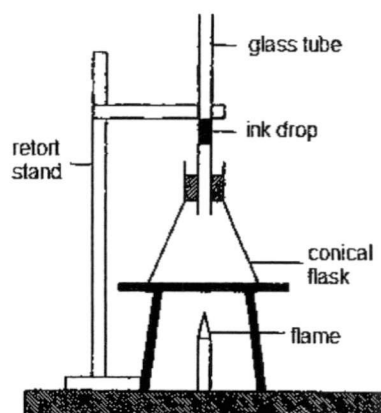

(a) State and explain any change that occurs in the motion of the air molecules in the conical flask as it is heated.

(a) The air molecules move faster or more vigorously [1] as they gain kinetic energy when temperature of air increases. [1]

1 m if student mentioned about hot air rises, cold air sinks.

No mark awarded if student wrote vibrate faster.

.....
.....
.. [2]

(b) Suggest and explain what will happen to the ink drop in the flask.

(b) The ink drop will rise [1] as the air expands and occupies greater volume.[1]

No mark awarded if student wrote air molecules expand

.....
.....
.. [2]

11 Evaporation and boiling are two processes which are similar yet different.

(a) State one similarity between evaporation and boiling

.....[1]

(b) Explain the following difference between evaporation and boiling.

“Boiling occurs throughout the liquid while from the exposed surface of the liquid”.

(a) Both processes describe change of state from liquid to gaseous [1]

(b) Only the more energetic molecules which are found at the surface of the water are about to break free from the water body to become vapour [1]

In boiling most / all molecules are have enough energy to break free from the water body to become vapour [1]

.....
.....
.....[2]

Section B

Answer any **two** questions.

Write your answers in the spaces provided.

12 Fig 12.1 below shows the velocity-time graph of two cars which started from the same point.

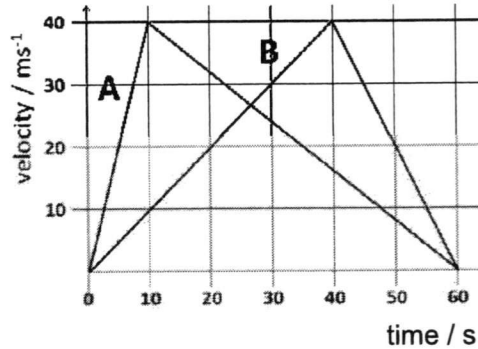

Fig 12.1

(a) Explain what is meant by uniform acceleration.

.....

.....

..... [1]

(b) Calculate the acceleration of car A during the first 10 seconds.

(a) State: Velocity change at a fixed rate. Explain : The change in the velocity is the same at any fixed interval of time

(b) $a = \text{change in } v / \text{time} [1] = 40 / 10 = 4 \text{ m/s}^2 [1]$

(c) $d = \frac{1}{2} \times 60 \times 40 = 1200 \text{ m} [1] \rightarrow v = 1200/60 = 20 \text{ m/s} [1]$

(d) The values are all of the same sign (positive)[1]

(e) Area under the curve for both cars are equal.[1]

acceleration = [2]

(c) Calculate the average speed of car A throughout the journey.

average speed = [2]

- (d) In Fig 12.2 and 12.3 below, sketch the acceleration-time graph and the displacement-time graph of B

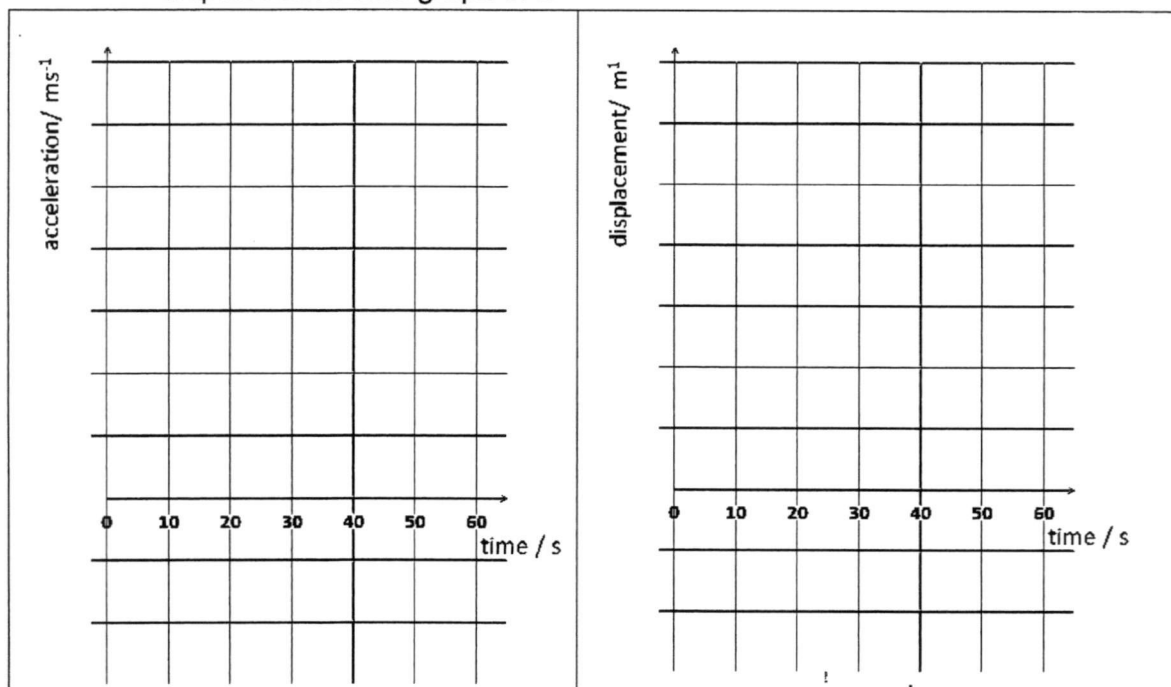

Fig 12.2

Fig 12.3

[3]

- (e) A student says that both cars are travelling in the same direction. Do you agree with him? Explain.

.....
 [1]

- (f) Did the two cars ended at the same point. Explain.

.....
 [1]

13 A uniform metre rule is balanced at the 50 cm mark. Loads of 1.5 N and 3.0 N are hung from the 10 cm and 40 cm marks respectively, as shown in the figure below. A weight W hanging from the 80 cm mark balances the system.

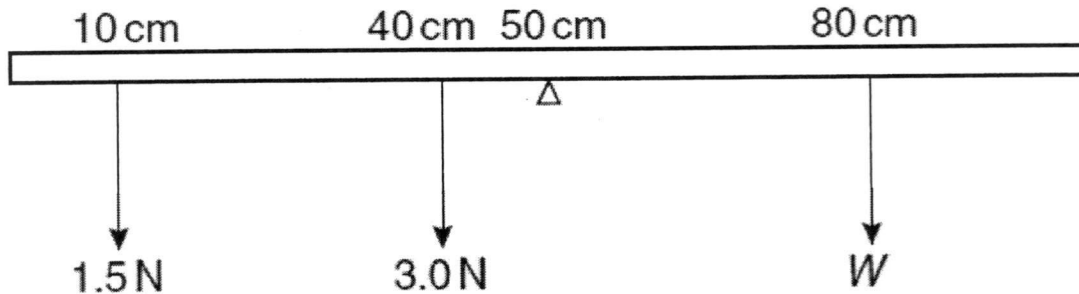

(a) State the Principle of Moments.

.....

 [2]

(b) Calculate the total moment of the 1.5 N and 3.0 N loads about the pivot. State the direction of rotation

(a) When a body is in equilibrium[*], the total moment [*] about the same pivot[*] should be zero[*]All 4* [2], 3*[1]
 (b) $1.5 \times 40 + 3 \times 10 = 90 \text{ Ncm}$ [1], anti clockwise [1]
 (c) $W \times 30 = 90$ [1] $\rightarrow W = 3 \text{ N}$ [1]
 (d) The ruler will tilt clockwise[1] because the clockwise moments > anticlockwise moment [1]
 (e) Show on diagram [1], the turning effect of the weight in this case is zero.

moment = direction of rotation = [2]

(c) Using the principle of moments, calculate the value of the weight W .

weight = [2]

(d) State and explain what will happen to the metre rule if weight W is shifted to

.....
.....[2]

(e) On the figure, indicate the centre of gravity of the metre rule with a 'X' and explain why is the weight of the metre rule not considered in the calculation in **(c)**.

.....
.....[2]

14 In the cooling system of an engine, fins made of metal are attached to the engine as shown in the figure below. Thermal energy is transferred away from the engine by conduction, convection and radiation.

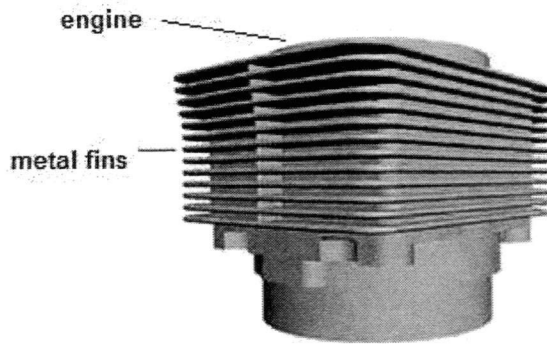

(a) State a similarity and a difference between conduction and convection.

(a) Both rely on particles to transfer heat [1]; both medium are of different states OR conduction rely on interaction between particles while convection rely on bulk movement of the particles [1]
 ONE via solid and ONE via liquid [1]

(b) Use ideas of thermal energy transfer to explain how the following features help to cool the engine.

(i) fins are made of metal

(b) (i) metals are good conductor of heat [1], so they can move thermal energy to the outer surface of the engine [1]

[2]

(ii) fins have large surface area

(b) (ii) large surface area better radiators [1], so they can radiate the heat OUT of the engine to the environment [1]

[2]

(iii) fins have spacing between them

(b) (iii) IN between fins have air [*], This is to enable convection to take place [*], so that there is another means to loose heat to the environment [*]... any 2

[2]

(c) A student suggests an additional feature to way to cool down the engine. That is to keep the fins wet at all times by spraying water on them. Do you think this will increase the cooling rate? Explain

(c) Yes because the water will evaporate [1] and cool down the engine further [1]
 OR No because water is a bad conductor of heat [1] as a result more heat could be trapped [1]

[2]

END OF PAPER

PERSIST!