

Visit

FreeTestPaper.com

for more papers

Name:	Index Number:	Class:
-------	---------------	--------

**YIO CHU KANG SECONDARY SCHOOL
END-OF-YEAR EXAMINATION 2016
SECONDARY THREE EXPRESS**



PHYSICS

Paper 1 Multiple Choice

5059/01

Friday

7 October 2016

45 minutes

Additional Material: Optical Answer Sheet (OAS)

READ THESE INSTRUCTIONS FIRST

Write in soft pencil on the OAS.
Do not use staples, paper clips, glue or correction fluid.
Write your name, index number and class on the OAS in the spaces provided.

There are **thirty** questions on this paper. Answer **all** questions.
For each question there are four possible answers **A, B, C** and **D**.
Choose the **one** you consider correct and record your choice in **soft pencil** on the separate OAS.

Read the instructions on the OAS very carefully.

Each correct answer will score one mark. A mark will not be deducted for a wrong answer.
Any rough working should be done in this question paper.
The use of an approved scientific calculator is expected, where appropriate.

- 1 The bob of a simple pendulum is pulled to one side and released. A portion of the motion during its swing is shown on the graph below.

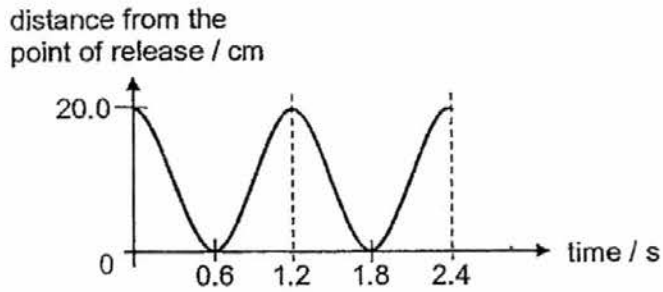

What is the period for this pendulum bob?

- A 0.6 s
 B 1.2 s
 C 1.8 s
 D 2.4 s
- 2 An aircraft heads north-west at 400 km/h. The wind is blowing from south-west at 150 km/h.

Which vector diagram represents the correct way to obtain the resultant velocity of the aircraft?

A

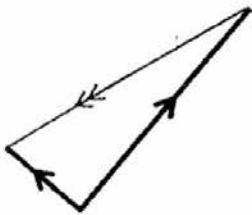

B

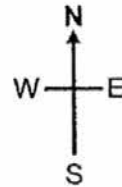
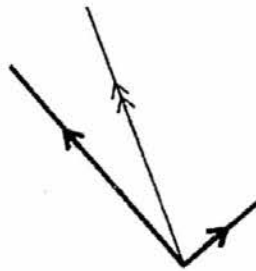

C

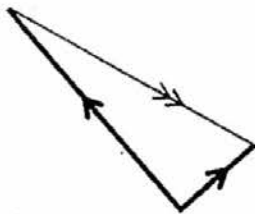

D

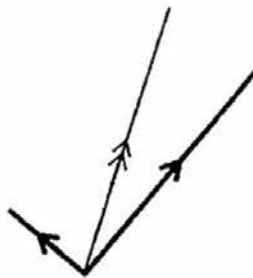

3 What is the order for the diameter of a coin and the diameter of the Earth?

	diameter of coin	diameter of Earth
A	22 mm	10 Gm
B	22 nm	10 Mm
C	22 mm	10 Mm
D	22 nm	10 Gm

4 A coconut is dropped from a tree. As the coconut falls, air resistance has a noticeable effect on its motion.

Graph 1 and 2 are displacement-time graphs. Graph 3 and 4 are velocity-time graphs.

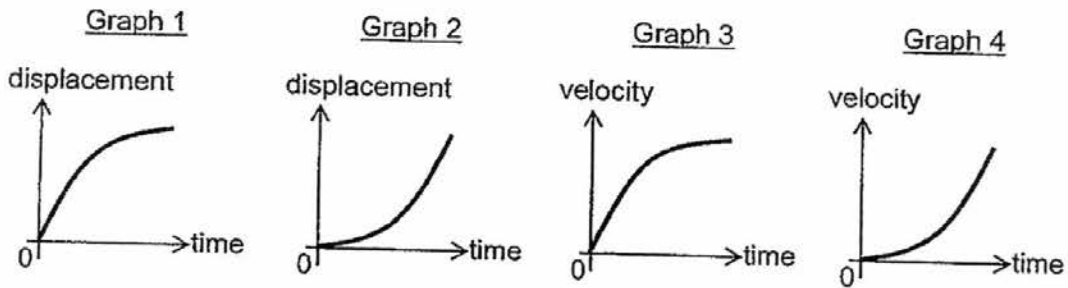

Which graphs represent the motion of the coconut?

- A graph 1 and 3
- B graph 1 and 4
- C graph 2 and 3
- D graph 2 and 4

5 The graph shows how the speed of a trolley changes as it moves across a floor.

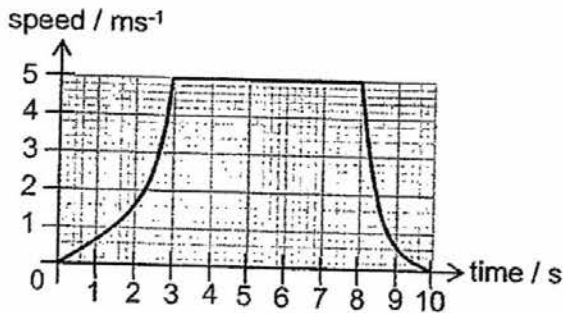

What is the distance travelled when the trolley is moving at constant speed?

- A 7.5 m
- B 25 m
- C 37.5 m
- D 50 m

- 6 The graph shows how the speed of a model car varies with time.

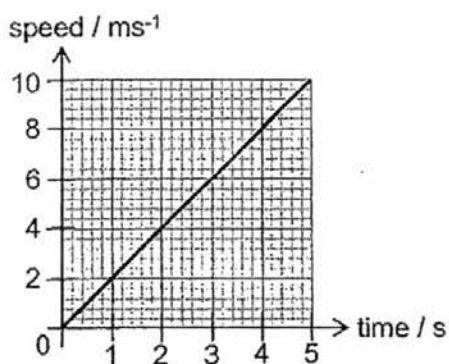

The resultant force on the model car is 0.60 N.

What is the mass of the car?

- A 0.03 kg
 B 0.06 kg
 C 0.3 kg
 D 1.2 kg
- 7 A lift moves upwards at a constant acceleration of 2 m/s^2 . The mass of the lift is 500 kg and the gravitational field strength is 10 N/kg .

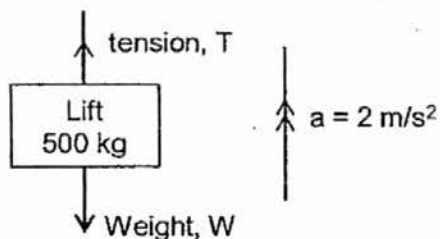

What is the tension in the cable holding the lift?

- A 1000 N
 B 4000 N
 C 5000 N
 D 6000 N

- 8 A wooden block is pushed across a table at constant speed.



Which statement is correct?

- A The frictional force increases as the block moves at constant speed.
 - B The frictional force is equal and opposite to the pushing force.
 - C The frictional force is greater than the pushing force.
 - D The frictional force is less than the pushing force.
- 9 A car, initially at constant speed along a road, drives onto a large patch of oil. The driver applies the brake to stop the car.

Compared to braking on a *dry* road, which of the following statements is true?

- A The car takes a longer time to decelerate to a stop because of the increased friction between the tyres and the road.
 - B The car takes a longer time to decelerate to a stop because of the reduced friction between the tyres and the road.
 - C The car takes a shorter time to decelerate to a stop because of the increased friction between the tyres and the road.
 - D The car takes a shorter time to decelerate to a stop because of the reduced friction between the tyres and the road.
- 10 Which property of a body resists a change in its state of rest or motion?

- A acceleration
- B mass
- C velocity
- D weight

- 11 Three objects are cut from the same sheet of metal. They are of different shapes but they all have the same mass.

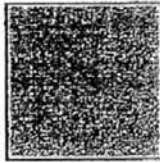

square

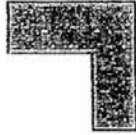

7-shape

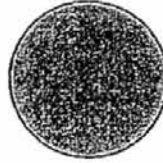

disc

Which object has the greatest density?

- A the square
 B the 7-shape
 C the disc
 D they all have the same density
- 12 An object has a weight of 250 N on Earth and 575 N on Jupiter.

What is the mass of the object and the gravitational field strength on the surface of Jupiter?

	mass / kg	gravitational field strength / Nkg^{-1}
A	25	10
B	25	23
C	57.5	10
D	57.5	23

- 13 A light aircraft stands at rest on the ground. It stands on three wheels, one at the front and two further back.

Which point could be its centre of mass?

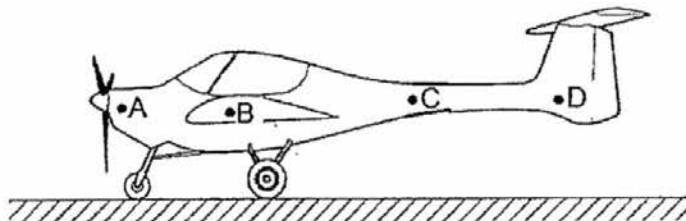

- 14 An object can be suspended in equilibrium from three different positions as shown.

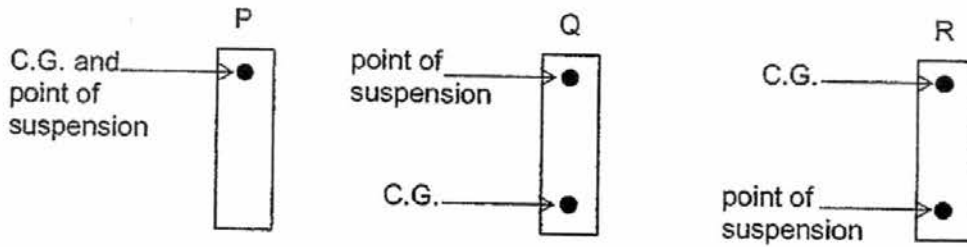

Which of the following matches the figures with their respective types of equilibrium?

	P	Q	R
A	neutral	stable	unstable
B	stable	neutral	unstable
C	stable	unstable	neutral
D	unstable	stable	neutral

- 15 The diagram below shows the cross-section of a regular pyramid of weight 15.0 N.

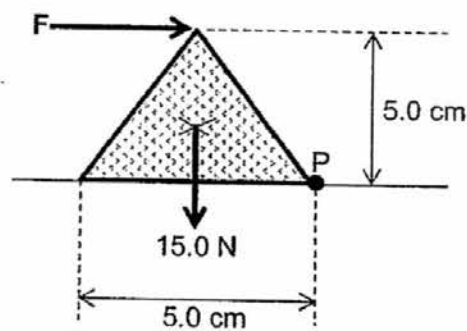

What is the **minimum** value of the force F that is required to just tilt the pyramid about the pivot point P ?

- A 0.133 N
- B 7.5 N
- C 15 N
- D 30 N

- 16 When a 400 N force is applied to a box weighing 800 N, the box moves 3.5 m horizontally in 20 s.

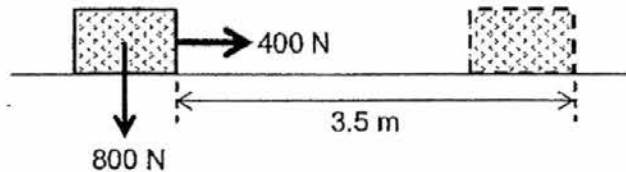

What is the average power?

- A 70 W
 - B 140 W
 - C 1400 W
 - D 2800 W
- 17 A battery supplies 500 J of electrical energy to a motor. The motor produces 200 J of heat.

What is the maximum efficiency of the motor?

- A 40 %
 - B 60 %
 - C 67 %
 - D 100 %
- 18 A ball is dropped from a height as shown.

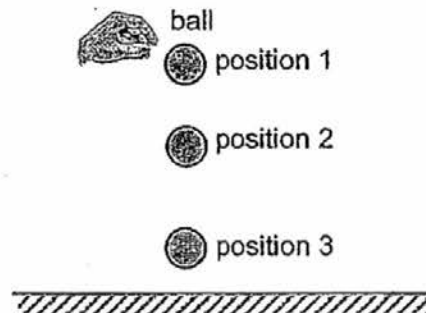

Ignoring the effects of air resistance, the **total** energy of the ball is

- A greatest at position 1.
- B greatest at position 2.
- C greatest at position 3.
- D the same at all positions.

- 19 A farmer has two carts. The carts have the same weight, but one has four narrow wheels and the other has four wide wheels.

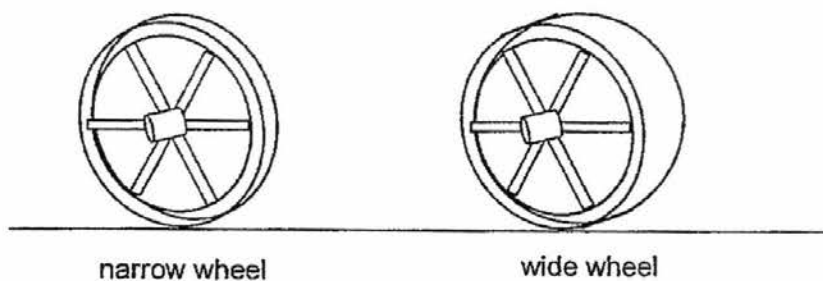

Which cart wheel sinks more into soft ground, and what is the reason?

	cart wheels	reason
A	narrow	greater pressure on the ground
B	narrow	lesser pressure on the ground
C	wide	greater pressure on the ground
D	wide	lesser pressure on the ground

- 20 The diagram shows a simple barometer.

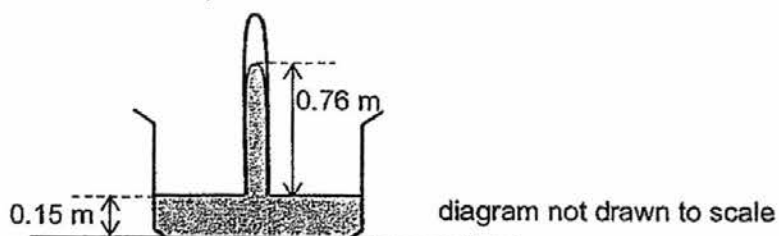

The density of mercury is $13\,600\text{ kg/m}^3$.

If the base of the container is $2.0 \times 10^{-3}\text{ m}^2$, find the force exerted on the base of the barometer.

- A $4.08 \times 10^1\text{ N}$
 B $1.66 \times 10^2\text{ N}$
 C $2.07 \times 10^2\text{ N}$
 D $2.48 \times 10^2\text{ N}$

- 21 A worker is preparing a granite table top for a kitchen. The table top has dimensions of 2.0 m by 0.8 m by 0.03 m and has a weight of 1300 N.

The worker rests the table top on the ground as shown.

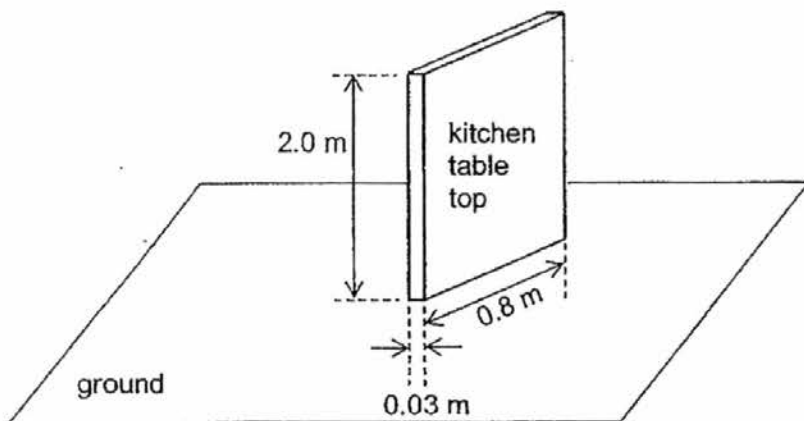

What is the pressure that the table top exerts on the kitchen floor?

- A $\frac{0.03 \times 0.8}{1300}$ Pa
- B $\frac{0.8 \times 2.0}{1300}$ Pa
- C $\frac{1300}{0.03 \times 0.8}$ Pa
- D $\frac{1300}{0.8 \times 2.0}$ Pa
- 22 A wave moves across the surface of the water in a ripple tank. In 1.0 minute, a wavefront moves a distance of 24 wavelengths.
- What is the frequency of the wave?
- A 0.2 Hz
- B 0.4 Hz
- C 2.5 Hz
- D 1440 Hz
- 23 Which of the following gives an example of a transverse wave and longitudinal wave?

	transverse wave	longitudinal wave
A	light	radio
B	radio	light
C	sound	water wave
D	water wave	sound

- 24 The diagram shows how displacement varies with time and distance as a wave passes a fixed point.

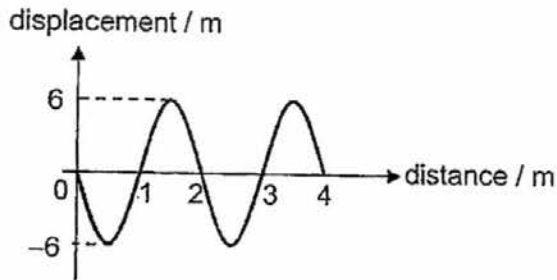

Which of the following correctly shows the amplitude and wavelength of the wave?

	amplitude / m	wavelength / m
A	6	2
B	6	4
C	12	2
D	12	4

- 25 An image is formed in a plane mirror as shown.

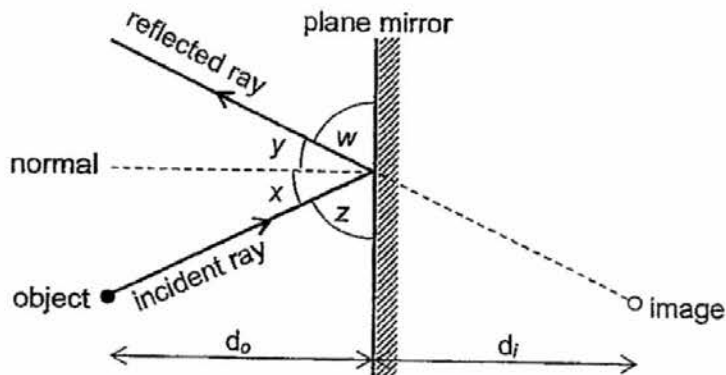

Which statement is correct?

- A Angle w is equal to angle z .
- B Distance d_i is more than distance d_o .
- C The image formed is real.
- D The sum of angle x and angle z is 180° .

- 26 An object is placed at the $2F$ position from a thin converging lens as shown.

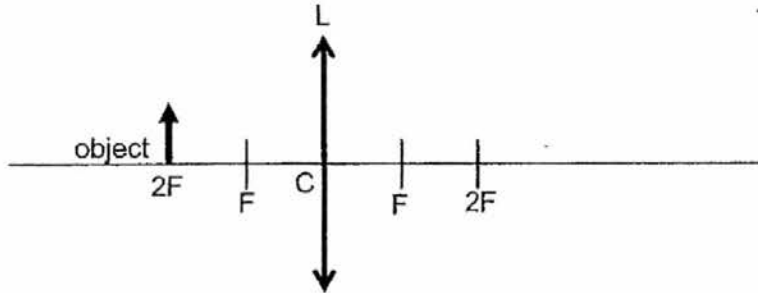

What are the application and characteristics of the image formed by this thin converging lens?

	application	image
A	camera	real, inverted and diminished
B	eye	virtual, upright and magnified
C	photocopier	real, inverted and same size as object
D	projector	real, inverted and magnified

- 27 Two rays of light strikes a diverging lens, L, as shown.

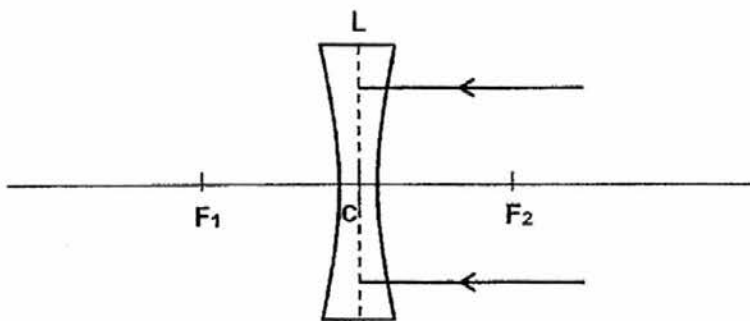

Which statement about the rays after they have passed through the lens is correct?

- A They appear to come from F_1
- B They appear to come from F_2 .
- C They appear to come from C.
- D They meet at F_1 .

- 28 The diagram below shows different regions of the electromagnetic spectrum.

radio waves		P	visible light			gamma rays
-------------	--	---	---------------	--	--	------------

Which of the following statements about P is correct?

- A P has a higher frequency than radio waves.
 B P has a higher speed in glass than in air.
 C P has a shorter wavelength than gamma rays.
 D P is damaging to health.
- 29 Given that the wavelength of the infra-red radiation is 2×10^{-5} m in vacuum, calculate the frequency of this infra-red radiation.
- A 6.7×10^{-14} Hz
 B 2×10^{-5} Hz
 C 3×10^8 Hz
 D 1.5×10^{13} Hz
- 30 Which of the following is **not** a property of electromagnetic waves?
- A All electromagnetic waves can be reflected and refracted.
 B All electromagnetic waves carry charges.
 C All electromagnetic waves carry energy.
 D All electromagnetic waves obey the wave equation.

Name:	Index Number:	Class:
-------	---------------	--------

**YIO CHU KANG SECONDARY SCHOOL
END-OF-YEAR EXAMINATION 2016
SECONDARY THREE EXPRESS**



PHYSICS

Paper 2

5059/02

Friday

7 October 2016

1 hour 30 minutes

No Additional Materials are required.

READ THESE INSTRUCTIONS FIRST

Write your name, index number and class on the cover page.

Write in dark blue or black ink.

You may use a soft pencil for any diagrams or graphs.

Do not use staples, paper clips, glue or correction fluid.

Section A

Answer **all** questions in the spaces provided.

Section B

Answer **all** questions in the spaces provided.

Candidates are reminded that **all** quantitative answers should include appropriate units.

The use of an approved scientific calculator is expected, where appropriate.

Candidates are advised to show all their working in a clear and orderly manner, as more marks are awarded for sound use of Physics than for correct answers.

The number of marks is given in brackets [] at the end of each question or part question.

You are advised to spend no longer than one hour on Section A and no longer than 30 minutes on Section B. At the end of the examination, fasten all your work securely together.

For Examiner's Use

Section A	/ 50
Section B	/ 20
Total	/ 70

Parent's / Guardian's signature

Name of Setter: Ms Teo HH

219

SECTION A

Answer all questions in this section in the spaces provided.

- 1 (a) A student uses a metre rule to determine the diameter of a golden sphere. Fig. 1.1 shows five golden spheres lined up beside each other with two wooden blocks supporting them at the sides.

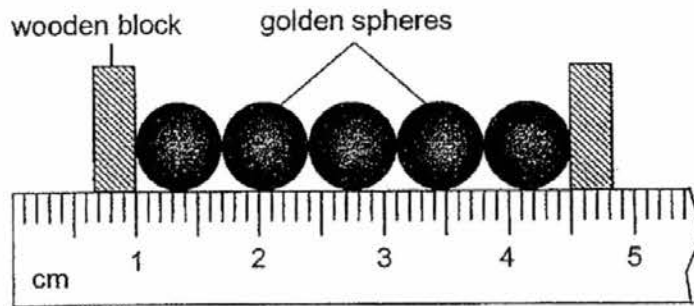

Fig. 1.1

- (i) Determine the average diameter of one golden sphere.

average diameter = [1]

- (ii) He realised that this method is not accurate.

State the instrument he should use instead and explain why it is better to use this instrument to measure the diameter of one golden sphere.

.....
.....
.....
..... [2]

- 1 (b) Fig. 1.2 shows the dimensions of a gold bar.

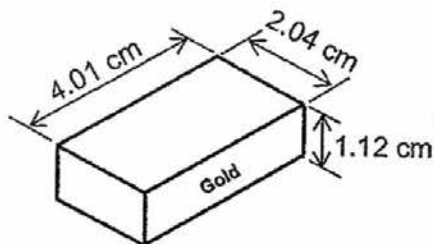

Fig. 1.2

The mass of the bar is 77.9 g and the weight of the bar is 0.779 N.

- (i) Explain the difference between *mass* and *weight*.

.....
.....
.....
.....
..... [2]

- (ii) Using the data from Fig. 1.2, calculate the density, in g/cm³, of the bar.

density of bar = g/cm³ [2]

- (iii) The density of pure gold is 19.3 g/cm³.

State and explain whether the bar is made of pure gold.

.....
.....
..... [1]

2. Fig. 2.1 shows a car of mass 2000 kg moving to the right with a forward driving force and air resistance acting on it.

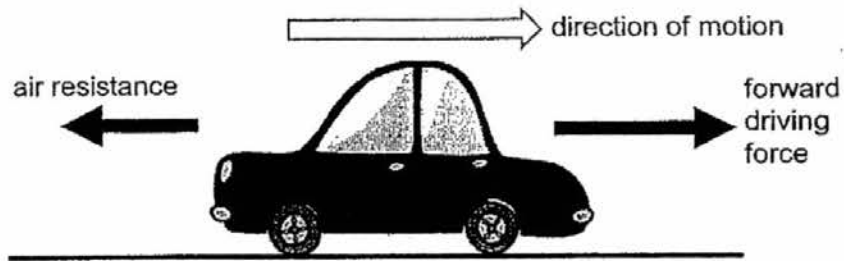

Fig. 2.1

Fig. 2.2 shows the variation of the forward driving force and resistive force that acts on the car with time.

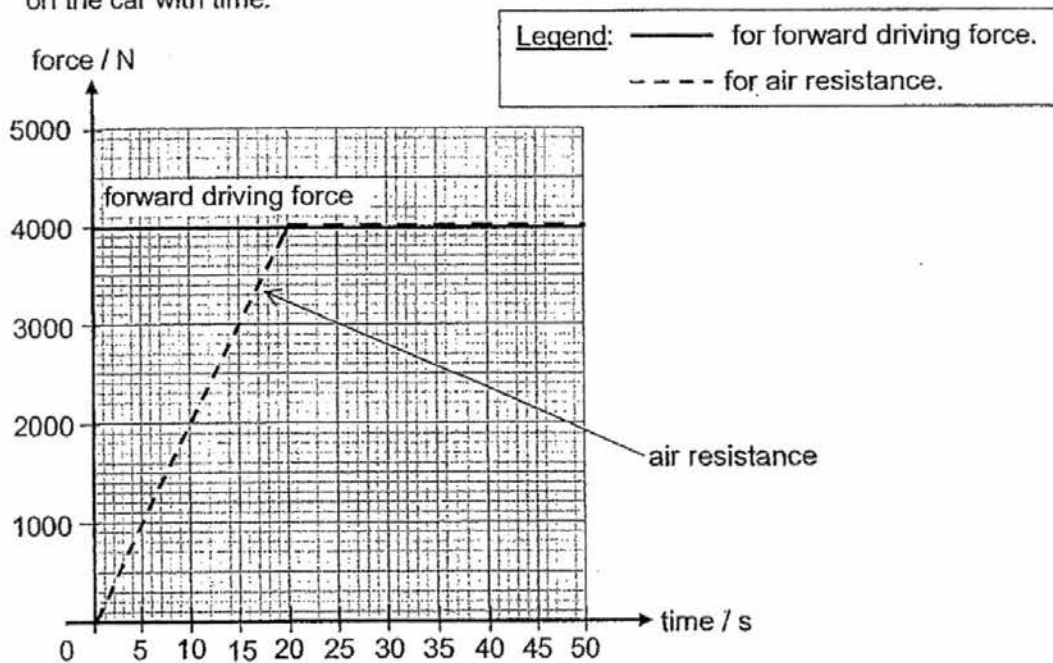

Fig. 2.2

- (a) The car is initially at rest.

Calculate the initial acceleration of the car.

initial acceleration = [2]

- 2 (b) The air resistance acting on the car increases uniformly in the first 20 s.

Describe and explain how the acceleration of the car changes in the first 20 s.

.....
.....
.....
.....
.....
..... [2]

- (c) (i) State the resultant force acting on the car after 20 s.

resultant force = N [1]

- (ii) Describe the acceleration and the velocity of the car after 20 s.

.....
.....
.....
.....
.....
..... [2]

3 Fig. 3.1 shows an arrow being fired vertically upward into the air by an archer.

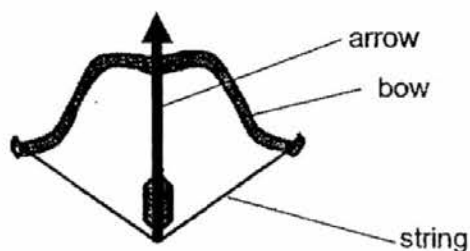

Fig. 3.1

The string of the bow is pulled back a distance of 55.0 cm using an average force of 120 N. The arrow has a mass of 0.18 kg.

(a) State the *Principle of Conservation of Energy*.

.....
.....
.....
.....
..... [1]

(b) Calculate the work done in pulling back the string in the bow.

work done = [2]

- 3 (c) When the string is released, 75% of the energy stored in the bow is transferred to the arrow. The gravitational field strength, $g = 10 \text{ N/kg}$.

Ignoring air resistance, determine

- (i) the initial speed with which the arrow leaves the bow,

speed of arrow = [2]

- (ii) the maximum height reached by the arrow.

۲۲

maximum height = [2]

- 4 Fig. 4.1 shows a mercury manometer being used to measure the pressure in a chamber containing gas and water. The height of the mercury column is 50 mm.

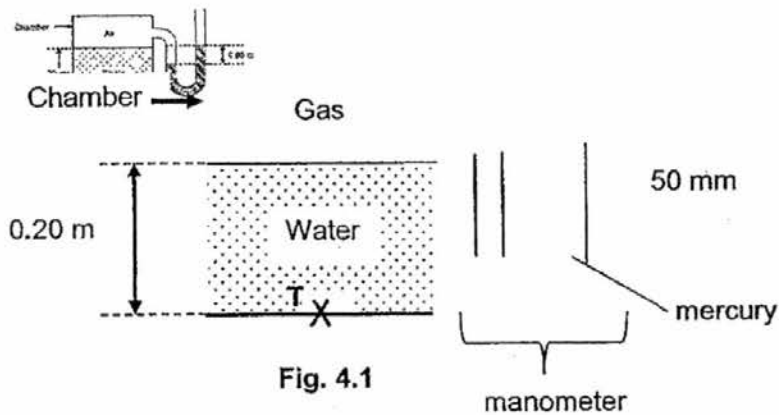

Fig. 4.1

- (a) State what is meant by *atmospheric pressure*.

.....
 [1]

- (b) If the pressure due to the gas trapped in the chamber is 810 mmHg, calculate the atmospheric pressure in mmHg.

atmospheric pressure = mmHg [1]

- (c) If the height of water in the chamber is 0.20 m and the density of water is 1000 kg/m^3 , calculate the pressure at T, in Pascal, due to the water only. The gravitational field strength, $g = 10 \text{ N/kg}$.

pressure at T due to water = Pa [2]

- 4 (d) The manometer tube is now replaced with another tube with a diameter *half* that of the original.

State if the new height of the mercury column is *greater than*, *smaller than* or *equal to* the original height of mercury column in the manometer.
Explain your choice of answer.

.....
.....
.....
.....
.....
..... [2]

- 5 Fig. 5.1 shows a series of floating buoys connected to a light string and are 1.5 m apart.

A sea wave is approaching the buoys as shown.

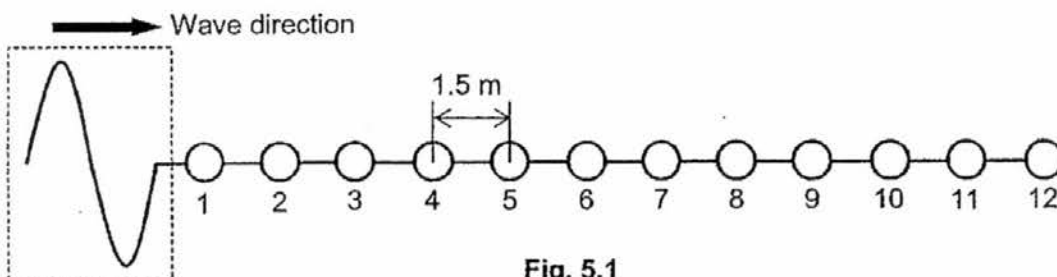

Fig. 5.1

- (a) Sea wave is a type of transverse wave. Part of the sea wave is shown in the dotted box in Fig. 5.1.

(i) Explain what is meant by a *transverse wave*.

.....

 [2]

(ii) Explain what is meant by a *wavefront*.

.....
 [1]

- (b) Indicate in Fig. 5.1, the direction that buoy 1 will move when the sea wave reaches it. [1]

- (c) It is observed that buoy 1 takes 5.0 s to make 6 complete oscillations.

Determine the frequency of the wave.

frequency = [1]

5 (d) Buoy 8 starts to move when buoy 1 just finishes a complete oscillation.

Determine

(i) the wavelength of the wave,

wavelength = [2]

(ii) the velocity of the sea wave.

204

velocity = [2]

- 6 Fig. 6.1 is drawn to scale. A thin converging lens, L, is used to produce a virtual image, which is 5 cm from the lens L.

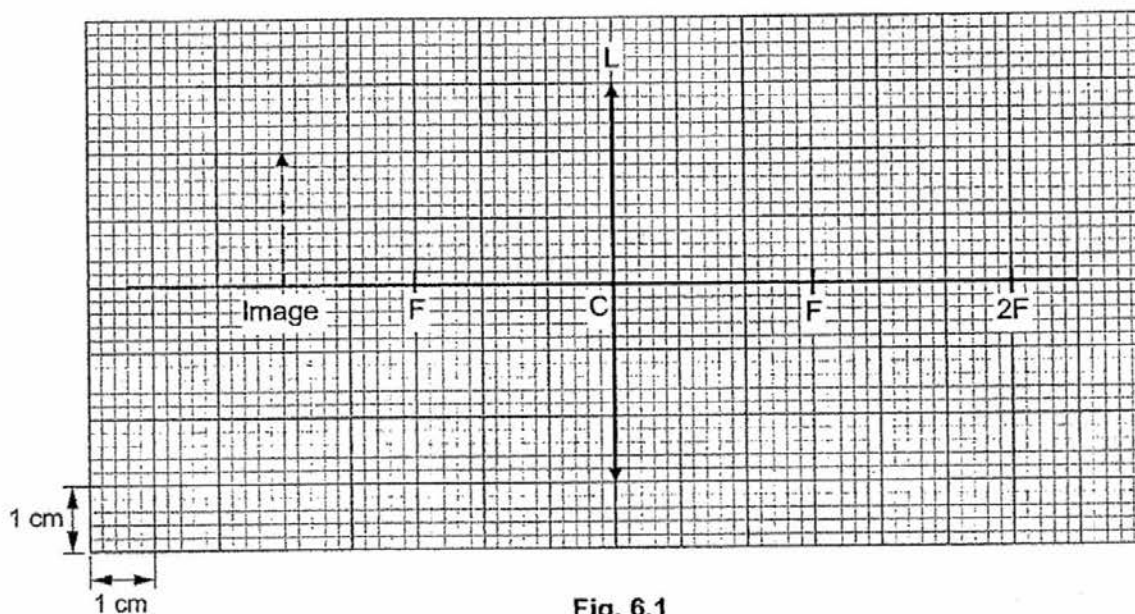

Fig. 6.1

- (a) The lens has a focal length of 3 cm.

State what is meant by *focal length*.

.....

 [1]

- (b) On Fig. 6.1, draw rays from the top of the image to locate the position of the object. Label the object clearly in your drawing. [3]

- (c) (i) Describe the image formed.

.....
 [1]

6 (c) (ii) State **one** application of the thin converging lens as shown in Fig. 6.1.
..... [1]

(d) The object is now moved closer to the lens.

State **one** change to the image formed.

.....
.....
..... [1]

- 7 (a) Electromagnetic radiation can be used for sending television signals to different parts of the Earth.

Fig. 7.1 shows two methods of sending television signals to points on the surface of the Earth.

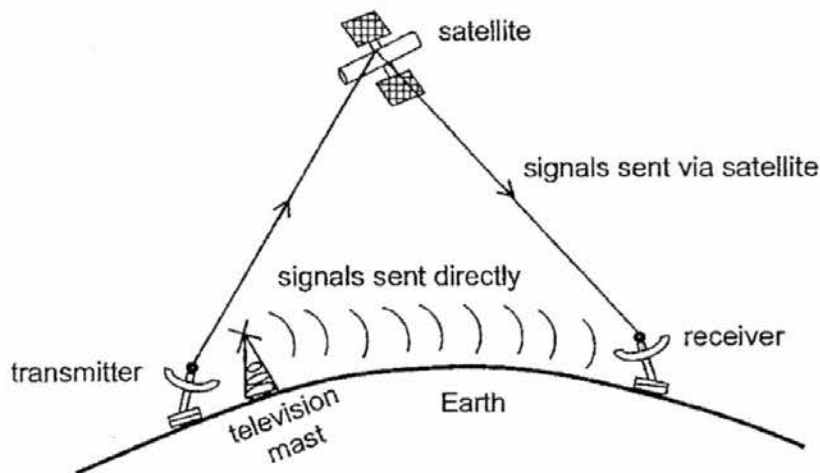

Fig. 7.1 (not to scale)

One method is to transmit waves *directly* to the receiver by a television mast.

A second method is to send the signals *via satellite* in space by a transmitter.

- (i) State which region of the electromagnetic spectrum is used for each method of transmitting television signals.

First method: [1]

Second method: [1]

- (ii) Between the two types of electromagnetic radiation which you have stated in (a)(i), which one has a *higher* frequency?

..... [1]

- 7 (a) (iii) A transmitter on Earth sends out signals of frequency 6000 MHz. The speed of electromagnetic waves in vacuum is 3×10^8 m/s.

Calculate the wavelength of the signal from the transmitter.

wavelength = [2]

- (b) Describe **one** harmful effect if too much electromagnetic radiation is absorbed by a human body.

.....
.....
..... [1]

SECTION B

Answer all questions in this section in the spaces provided.

- 8 (a) State the *Principle of Moments for a body in equilibrium*.

.....

.....

..... [1]

- (b) Fig. 8.1 shows the essential features of a vehicle's hydraulic braking system.

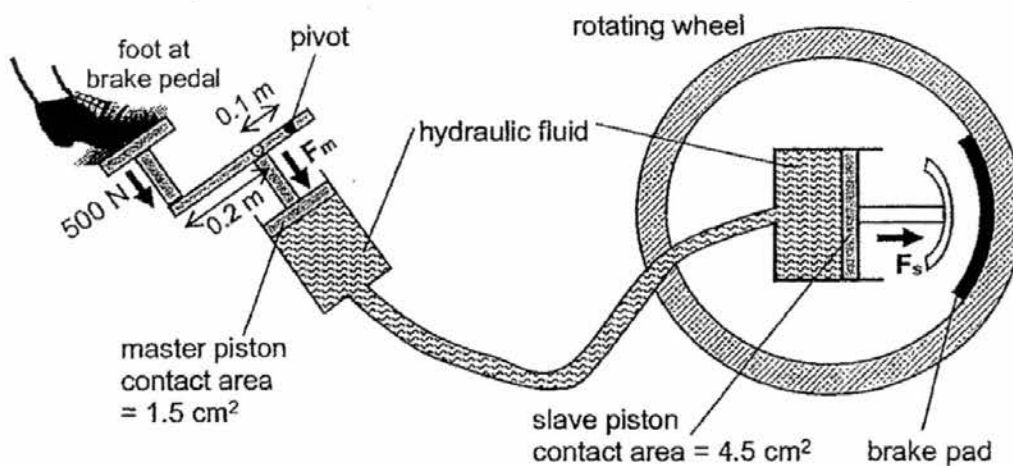

Fig. 8.1

A force of 500 N is applied by the driver on the brake pedal.

- (i) Show that the moment produced by this 500 N force about the pivot is 150 Nm.

- 8 (b) (ii) The moment produced by this 500 N force is translated to the moment produced by the force, F_m , on the master piston.

Using the answer obtained in (b)(i) and applying the Principle of Moments, calculate the force, F_m , exerted on the master piston when the driver exerts a force of 500 N on the brake pedal.

force, F_m = [2]

- (iii) Hence, calculate the pressure in N/cm^2 , exerted on the fluid by the master piston.

pressure on fluid = N/cm^2 [2]

- (iv) The hydraulic fluid is effective in transmitting the pressure exerted by the master piston to the slave piston.
State the pressure exerted on the slave piston.

pressure on slave piston = [1]

- (v) Hence, calculate the force, F_s , exerted on the brake pad.

F_s = [2]

- (vi) Suggest **one** modification to this system to minimise the force exerted by foot at brake pedal to brake the car.

.....

.....

227

..... [1]

- 9 Fig. 9.1 shows two light rays travelling through an optical fibre made of glass.

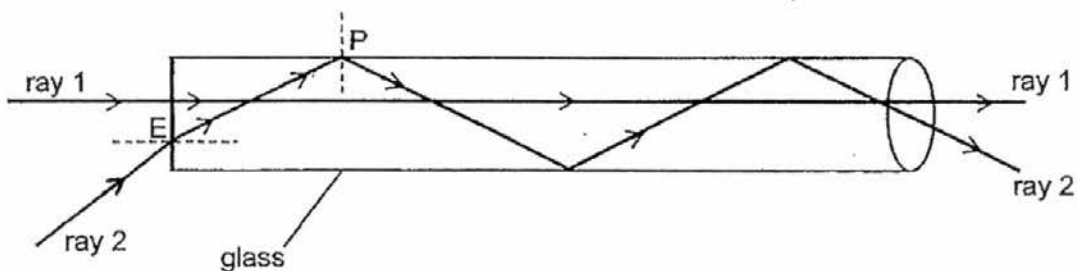

Fig. 9.1 (not drawn to scale)

The two rays travel in different paths as they enter the optical fibre with different angles of incidence. Fig. 9.2 gives information about the angles of the two rays and their paths in the optical fibre.

	angle of incidence / °	angle of refraction / °
ray 1	0	x
ray 2	35	y

Fig. 9.2

- (a) The refractive index of the glass is 1.49.

Using the data in Fig. 9.2, determine the angle of refraction for

- (i) ray 1,

angle of refraction, $x = \dots\dots\dots^\circ$ [1]

- (ii) ray 2.

angle of refraction, $y = \dots\dots\dots^\circ$ [2]

9 (b) (i) State what is meant by *critical angle*.

.....
.....
..... [1]

(ii) Determine the critical angle of optical fibre.

critical angle =° [2]

(c) State and explain what happens to ray 2

(i) at point E,

.....
.....
..... [1]

(ii) at point P.

.....
.....
.....
.....
.....
.....
..... [3]

BLANK PAGE

PAPER ONE (MCQ):

1.	B	Time taken for 1 complete oscillation = Time between 2 successive crests (or trough) = $(1.2 - 0) = 1.2$ s.
2.	B	
3.	C	Diameter of coin = 2.2 cm = 22 mm Diameter of Earth = 1×10^7 m = 10×10^6 m = 10 Mm
4.	C	Gradient of displacement-time graph gives velocity while gradient of velocity-time graph gives acceleration. As coconut falls from the tree, velocity increases from zero (graph 2). As coconut falls, acceleration due to gravity decreases until it reaches terminal velocity where acceleration is zero (graph 3).
5.	B	Constant speed from time = 3 s to 8 s. Distance = Area under speed-time graph = $5 \times (8 - 3) = 25$ m.
6.	C	Acceleration = gradient = $\frac{v-u}{t} = \frac{10-0}{5-0} = 2$ m/s ² . Since resultant force = ma, mass = $\frac{F}{a} = \frac{0.60}{2} = 0.3$ kg
7.	D	Weight of lift in downward direction = $mg = 500 \times 10 = 5000$ N. Since lift is moving upwards, resultant force = ma \Rightarrow Tension in upward direction - weight = ma \Rightarrow Tension - 5000 = 500 (2) \Rightarrow Tension = 1000 + 5000 = 6000 N
8.	B	Constant speed \Rightarrow zero acceleration So resultant force acting on the block is zero. The frictional force is equal and opposite to the pushing force.
9.	B	Oil reduces friction between tyres and ground as compared to braking on a dry road. It will take longer to come to a stop.
10.	B	Inertia is directly proportional to the mass of an object to resist a change in its state of rest or motion. The greater the mass, the greater the inertia.
11.	D	The density of all the 3 objects will be the same as they are made of the same material.
12.	B	Mass of object = $\frac{W}{g} = \frac{250}{10} = 25$ kg. Mass on Earth is same as mass on Jupiter. \therefore g on Jupiter = $\frac{\text{Weight on Jupiter}}{\text{mass}} = \frac{575}{25} = 23$ N/kg
13.	B	C.G. must be within the base between the wheels.
14.	A	P: Object is in neutral position since C.G. and point of suspension coincides. Q: Object is stable if the vertical line through the C.G. of the object is through the point of suspension and C.G. is below the point of suspension.
15.	B	The perpendicular distance between weight and pivot = $\left(\frac{0.05}{2}\right) = 0.025$ m By Principle of Moments, S.C.M. = S.A.M. $F \times 0.05 = 15 \times 0.025$ Min. F = $\left(\frac{15 \times 0.025}{0.05}\right) = 7.5$ N

16.	A	$\text{Power} = \frac{\text{Work done}}{\text{time taken}} = \frac{\text{Force} \times \text{distance in direction of force}}{\text{time taken}} = \frac{400 \times 3.5}{20} = 70 \text{ W}$
17.	B	$\text{Efficiency} = \frac{\text{Useful output energy}}{\text{Total input energy}} \times 100\% = \frac{(500-200)}{500} \times 100\% = 60\%$
18.	D	By the Principle of Conservation of energy, total energy remains constant at any point of the drop.
19.	A	Narrow wheel: Base area in contact with the ground is small, so greater pressure is exerted by the wheel as compared to the wide wheel since both type of wheels have the same weight.
20.	D	Force exerted on base of barometer = Pressure \times Area in contact = $h_{\text{Hg}} \times \rho_{\text{Hg}} \times g \times \text{Base area of container}$ = $(0.76 + 0.15) \times 13\,600 \times 10 \times (2 \times 10^{-3})$ = 247.52 N = $2.4752 \times 10^2 \text{ N}$ $\approx 2.48 \times 10^2 \text{ N}$ (to 3 s.f.)
21.	C	$\text{Pressure} = \frac{\text{Weight of worktop}}{\text{Area in contact with floor}}$
22.	B	24 wavelengths in 1 min \Rightarrow In 60 s, 24 complete waves are produced. \Rightarrow In 1 s, $\frac{24}{60} = 0.4$ complete wave produced. $\therefore f = 0.4 \text{ Hz}$
23.	D	Sound wave is a longitudinal wave. The rest are transverse waves.
24.	A	Amplitude is the maximum height of crest from the rest position. $A = 6 \text{ m}$ Wavelength is the horizontal distance between 2 successive crests (or troughs). $\lambda = 2 \text{ m}$.
25.	A	By Laws of reflection, angle of incidence = angle of reflection. So angle $w = \text{angle } z$.
26.	C	If object is placed at 2F position, image formed is also at 2F position on the other side of the lens \Rightarrow real, inverted and same size as the object.
27.	B	The parallel rays will diverge (split) after going through the diverging lens and the rays appears to come from F_2 position.
28.	A	P is an Infra-red radiation. Radio waves have the longest wavelength and lowest frequency in the EM spectrum.
29.	D	Speed of EM waves = Speed of light = $3 \times 10^8 \text{ m/s}$. $f = \frac{v}{\lambda} = \frac{3 \times 10^8}{2 \times 10^{-5}} = 1.5 \times 10^{13} \text{ Hz}$
30.	B	Electromagnetic waves do NOT carry any charge.

PAPER TWO

[-1 mark] from OVERALL for missing working or poor presentation without formula;
 [-1 mark] from OVERALL for missing 3 s.f. or units.

Section A:

1	(a)(i)	Average diameter of one golden sphere = $\frac{(4.5-1)}{5} = 0.7 \text{ cm}$	[1]
	(ii)	He should be using a <u>micrometer screw gauge</u> as it is <u>more precise</u> or can measure up to <u>0.01 mm</u> or <u>0.001 cm</u> . Or <u>Vernier calipers</u> as it is <u>more precise</u> or can measure up to <u>0.01 cm</u> .	[1] [1]
	(b)(i)	Mass is the <u>amount of matter</u> in the object. Weight is a <u>force due to gravitational pull</u> .	[1] [1]
	(ii)	Volume = $(4.01 \times 2.04 \times 1.12) = 9.1620 \text{ cm}^3$. \therefore density of bar = $\frac{\text{mass}}{\text{volume}} = \frac{77.9}{9.1620}$ $= 8.5025$ $\approx 8.50 \text{ g/cm}^3$ (to 3 s.f.)	[1] for working [1]
	(iii)	Since density of bar is <u>less than</u> the density of pure gold given, this bar is <u>NOT made of pure Gold</u> .	[1]
			8 mks
2	(a)	Resultant $F = ma$ \therefore Initial acceleration = $\frac{\text{resultant force}}{\text{mass}}$ $= \frac{4000}{2000}$ $= 2 \text{ m/s}^2$	[1] [1]
	(b)	As air resistance increases, the <u>resultant force</u> acting on the car <u>decreases</u> . Since resultant force = ma , therefore the <u>resultant acceleration</u> of the car <u>decreases</u> .	[1] [1]
	(c)(i)	After time = 20 s; Since forward driving force has the same value (4000 N) as the air resistance, the <u>resultant force acting on the car is 0 N</u> .	[1]
	(c)(ii)	<u>Resultant acceleration is zero</u> . \Rightarrow The car is moving with <u>constant velocity</u> .	[1] [1]
			7 marks
230			

3	(a)	Principle of conservation of energy states that energy <u>cannot be created nor destroyed, but can be converted from one FORM to another.</u> The total energy in an isolated system is constant.	[1]
	(b)	Work done in pulling back the string in the bow = Pulling force \times distance in the direction of force = $120 \text{ N} \times \frac{55}{100} \text{ m}$ = 66 J	[1] [1]
	(c)(i)	By Conservation of energy, Gain in K.E. for arrow = $\frac{75}{100} \times$ Energy stored in the bow $\frac{1}{2} mv^2 = \frac{75}{100} \times 66$ $\frac{1}{2} \times 0.18 \times v^2 = 49.5$ $v = \sqrt{\left[\frac{49.5 \times 2}{0.18} \right]}$ $= 23.452$ $\approx 23.5 \text{ m/s}$ (to 3 s.f.) \therefore Speed of arrow = 23.5 m/s	[1] with ecf for working [1] with ecf
	(c)(ii)	By Conservation of energy, Gain in GPE = Loss in KE $mgh = \frac{75}{100} \times 66$ $0.18 \times 10 \times h = 49.5$ $h = \frac{49.5}{(0.18 \times 10)}$ $= 27.5 \text{ m}$ \therefore Maximum height reached by arrow = 27.5 m	[1] with ecf for working [1] with ecf
			7 marks
4	(a)	Atmospheric pressure is the <u>pressure exerted by the air molecules on the surface of Earth.</u>	[1]
	(b)	Height of mercury column = 50 mm Pressure = 810 mm Hg $P_{\text{atm}} + P_{\text{Hg}} = 810 \text{ mm Hg}$ $\therefore P_{\text{atm}} = (810 - 50) \text{ mm Hg}$ = 760 mm Hg	[1] with working
	(c)	Pressure at T due to water only = $h_{\text{water}} \times \rho_{\text{water}} \times g$ = $0.20 \times 1000 \times 10$ = 2000 Pa	[1] [1]
	(d)	The new height of mercury column is <u>equal to the original height of mercury column in the tube.</u> <u>Reason:</u> Since pressure in liquid = $h_{\text{Hg}} \times \rho_{\text{Hg}} \times g$, pressure is <u>independent of the diameter</u> of the tube in manometer.	[1] [1]

			6 marks
5	(a)(i)	A transverse wave is a wave which <u>transfers energy by vibrations from one place to another without transferring the medium.</u> The transverse wave travels in a direction <u>perpendicular</u> to the direction of the vibrations.	[1] [1]
	(ii)	Wavefront is an <u>imaginary line</u> on a wave that <u>joins all adjacent points</u> that are <u>in phase.</u>	[1]
	(b)	Ball 1 will move <u>downwards</u> when the wave reaches it.	[1]
	(c)	In 5 s, 6 complete oscillations are produced. \Rightarrow In 1 s, $\frac{6}{5} = 1.2$ complete oscillations are produced. $\therefore f = 1.2 \text{ Hz}$ ← MUST write this	[1]
	(d)(i)	Distance between buoy 1 and 8 = one wavelength No. of gaps between buoy 1 and 8 = 7 gaps. Wavelength = $7 \times 1.5 \text{ m}$ $= 10.5 \text{ m}$.	[1] [1]
	(ii)	$v = f \lambda$ $= 1.2 \times 10.5$ $= 12.6 \text{ m/s}$	[1] with ecf [1] with ecf
			9 marks
231			

6	(a)	Focal length is the <u>distance between</u> the <u>optical centre</u> of the lens and the <u>focal point</u> .	[1]
---	-----	--	-----

(b)

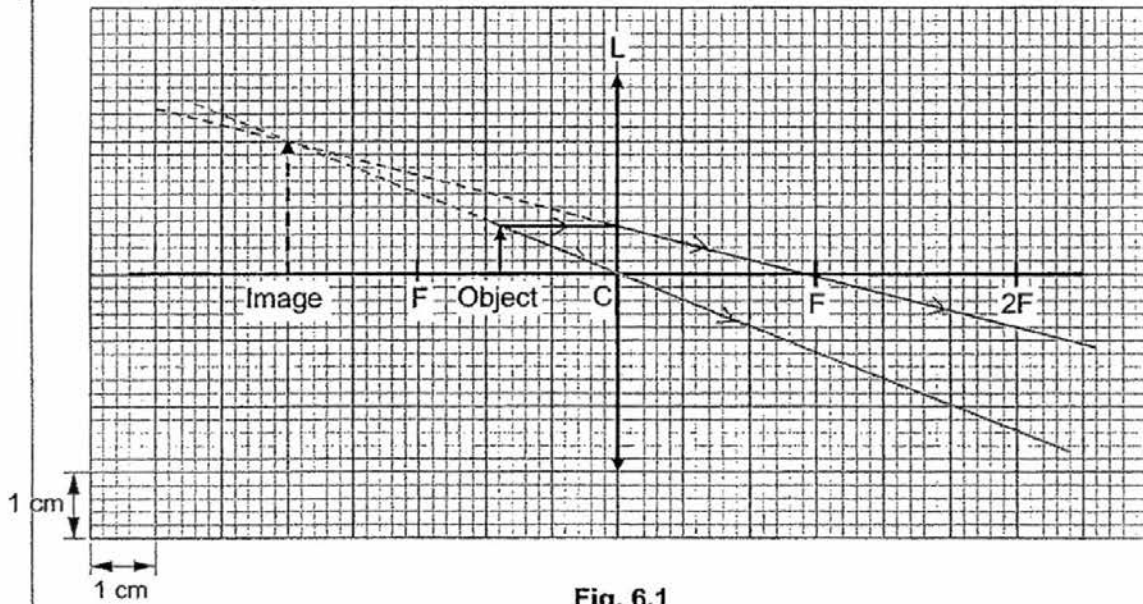

Fig. 6.1

[1] for ray through optical centre of L.
 [1] for ray through F on the right of L.
 [1] for position of object WITH labelling.
 [-1] for wrong types of line (dotted or solid line) or missing (or wrong) arrows.

	(c)(i)	Image formed is <u>virtual, upright</u> and <u>magnified</u> .	[1]
	(c)(ii)	<u>Magnifying glass</u> . <u>Note: Only magnifying glass will produce a virtual, upright and magnified image.</u>	[1]
	(d)	When object is moved closer to the lens, <u>height of image</u> will <u>decrease</u> .	[1]
			7 marks

7	(a)(i)	First method: Radio waves Second method: Microwaves	[1] [1]
	(ii)	<u>Microwaves</u> have higher frequency as compared to radio waves.	[1] with ecf
	(iii)	$f = 6000 \text{ MHz} = 6000 \times 10^6 \text{ Hz} = 6 \times 10^9 \text{ Hz}$ $\lambda = \frac{v}{f} = \frac{3 \times 10^8}{6 \times 10^9}$ $= 0.05 \text{ m}$	[1] [1] with ecf
	(b)	The <u>ionising effect</u> of some electromagnetic waves will <u>damage the cells and tissues</u> when the human is overexposed to it, causing health problems such as cancer.	[1]
			6 marks
Section B:			
8	(a)	The Principle of Moments states that when a body is <u>in equilibrium</u> , the <u>sum of clockwise moments about a pivot is equal to the sum of anticlockwise moments about the same pivot.</u>	[1]
	(b)(i)	Moment produced by 500 N force = Force \times maximum \perp distance from force to pivot = 500 N \times 0.3 m = 150 Nm (Shown)	[1]
	(ii)	Moment by F_m on master piston = Moment by 500 N force $F_m \times 0.1 = 150$ $\therefore F_m = \frac{150}{0.1}$ $= 1\,500 \text{ N}$ \therefore Force $F_m = 1\,500 \text{ N}$.	[1] [1]
	(iii)	Pressure exerted on fluid by master piston $= \frac{\text{Force}}{\text{Area in contact}} = \frac{1\,500 \text{ N}}{1.5 \text{ cm}^2}$ $= 1\,000 \text{ N/cm}^2$	[1] with ecf [1] with ecf
	(iv)	Pressure on slave piston = Pressure from master piston = 1 000 N/cm ²	[1] with ecf
	(v)	Pressure on slave piston = Pressure by master piston $\frac{\text{Force on brake pad}}{\text{Base area of slave piston}} = 1\,000 \text{ N/cm}^2$ $\frac{F_s}{4.5} = 1\,000$ $\therefore F_s = 4.5 \times 1000$ $= 4\,500 \text{ N}$	[1] with ecf [1] with ecf
			332

8	(b)(vi)	To minimise the force required to brake the car: <ul style="list-style-type: none"> • Increase perpendicular distance between brake pedal and pivot; • Decrease the contact area of master piston; • Increase the contact area of slave piston. 	Either one [1]
			10 marks
9	(a)(i)	Ray 1: Since $\angle i = 0^\circ$, $\angle r = 0^\circ$	[1]
	(ii)	Ray 2: $\angle i = \angle$ in air $= 35^\circ$, $n = \frac{\sin(\angle \text{ in air})}{\sin(\angle \text{ in glass})}$ $1.49 = \frac{\sin 35^\circ}{\sin r}$ $\sin r = \frac{\sin 35^\circ}{1.49}$ $\angle r = \sin^{-1}\left(\frac{\sin 35^\circ}{1.49}\right)$ $= 22.640^\circ$ $\approx 22.6^\circ$ (to 1 d.pl.)	[1] [1]
	(b)(i)	Critical angle is the <u>angle of incidence in an optically denser medium for which the angle of refraction in the optically less dense medium is 90°.</u>	[1]
	(ii)	$n = \frac{1}{\sin c}$ $\angle c = \sin^{-1}\left[\frac{1}{n}\right]$ $= \sin^{-1}\left[\frac{1}{1.49}\right]$ $= 42.155^\circ$ $\approx 42.2^\circ$ (to 1 d.pl.)	[1] [1]
	(c)(i)	At point E, Ray 2 will <u>bend towards the normal</u> as it <u>enters</u> an <u>optically denser medium</u> .	[1]
	(ii)	At point P, Ray 2 undergoes <u>total internal reflection</u> , as it is travelling <u>from an optically denser medium to an optically less dense medium</u> . The <u>angle of incidence is greater than the critical angle</u> .	[1] [1] [1]
			10 marks