

Visit

FREETESTPAPER.com

for more papers



Website: [freetestpaper.com](http://www.freetestpaper.com)



[Facebook.com/freetestpaper](https://www.facebook.com/freetestpaper)



[Twitter.com/freetestpaper](https://www.twitter.com/freetestpaper)

Name: _____	Class	Index Number
	_____	_____



Jurong West Secondary School
End-of-Year Examinations 2022



PHYSICS

6091/01

Secondary Three Express

Tuesday, 11 October 2022

Paper 1 Multiple Choice

0800 – 0845

45 minutes

Candidates answer on the Multiple Choice Answer Sheet.

Additional Materials: Multiple Choice Answer Sheet

READ THESE INSTRUCTIONS FIRST

Write your name, class and index number on all the work you hand in.

Write in soft pencil.

You may use an HB pencil for any diagrams, graphs, tables or rough working.

Do not use staples, paper clips, glue or correction fluid.

The use of an approved scientific calculator is expected, where appropriate.

There are **thirty** questions on this paper. Answer **all** questions. For each question there are four possible answers **A, B, C** and **D**. Choose the **one** you consider correct and record your choice in **soft pencil** on the separate Answer Sheet. **Read the instructions on the Answer Sheet very carefully**. Each correct answer will score one mark. A mark will not be deducted for a wrong answer. Any rough working should be done in this question paper.

After checking of answer script		
Checked by Student	Signature	Date

This document consist of **14** printed pages (including the cover page)

Page 1 of 14

Setter: Mr Lim YT

PartnerInLearning
188

- 1 A pendulum clock is found to be slow. In order to set the clock right,
- A decrease its amplitude of oscillation.
 - B decrease the pendulum length.
 - C increase its amplitude of oscillation.
 - D increase the pendulum length.
- 2 A length of copper pipe, of uniform cross-section and several metres long, carries water to a tap.

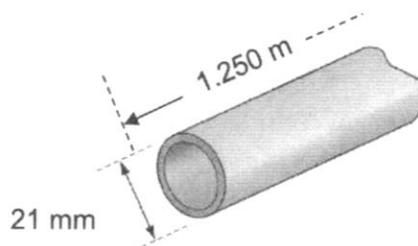

Measurements are taken to determine accurately the volume of copper in the pipe.

Which instruments are used?

- A calipers and micrometer
 - B micrometer and rule
 - C rule and tape
 - D tape and calipers
- 3 The following statements were made about motion by a student.
- 1 A plane flies due East for 600 km.
 - 2 A runner's average speed in a race around a track is 5 m/s.
 - 3 A snail crawls at 3 mm/s in a straight line towards a lettuce.
 - 4 A tourist travels 500 km on a journey.

Which statements best describe vector quantities?

- A 1 and 2
- B 1 and 3
- C 2 and 3
- D 2 and 4

- 4 A student measures the speed of a trolley. At one instant, the speed of the trolley is 1.0 m/s and two seconds later the speed is 4.0 m/s.

What is the acceleration of the trolley?

- A 1.5 m/s²
B 2.0 m/s²
C 2.5 m/s²
D 5.0 m/s²
- 5 The following graph shows the speed-time graph of an object.

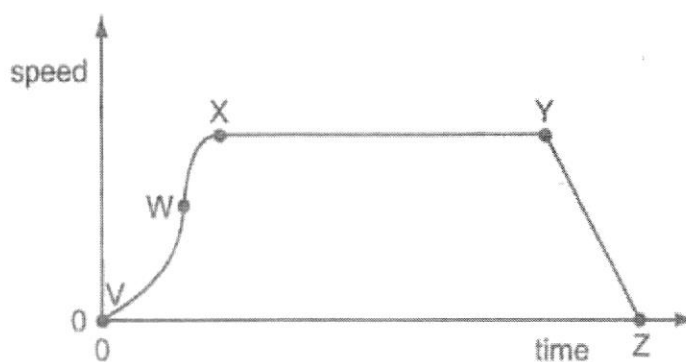

In which region is the acceleration decreasing?

- A V to W
B W to X
C X to Y
D Y to Z

- 6 The diagram below shows the distance-time graphs of Cars J and K.

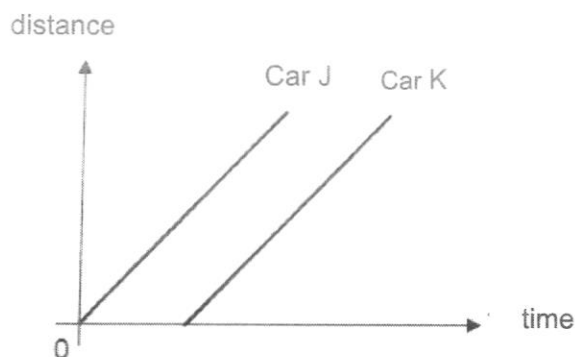

Which of the following statements can be deduced from the graph?

- A Car J and Car K are both travelling at constant speeds.
 B Car J is always traveling at a higher speed than Car K.
 C Car J has a greater acceleration than Car K.
 D Car K started travelling before Car J.
- 7 A small stone is dropped from the top of a ladder, falls and hits the ground. It does not rebound.

Which speed-time graph is correct?

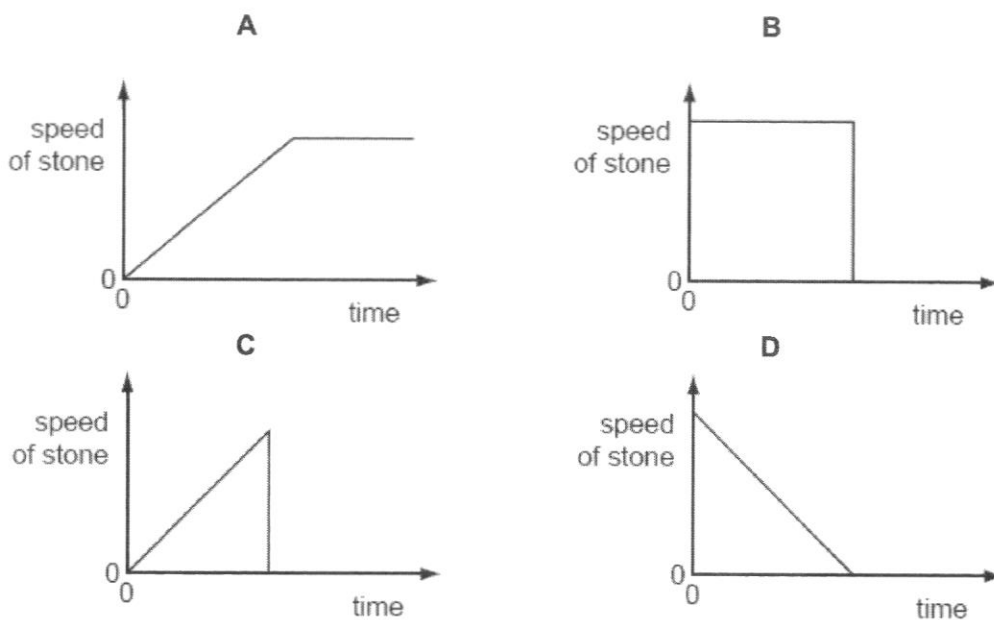

- 8 What is the force due to air resistance acting on a 0.50 kg object falling vertically with an acceleration of 8.5 m/s^2 ? (Assume $g = 10 \text{ N/kg}$)

A 0.75 N
 B 4.25 N
 C 5.00 N
 D 9.25 N

- 9 An engine pulls a truck at constant speed on a level track.

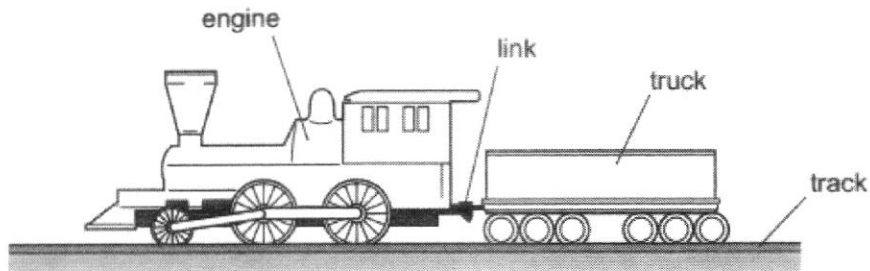

The link between the truck and the engine breaks. The driving force on the engine remains constant.

What effect does this have on the truck and on the engine?

	truck	engine
A	slows down	speed stays constant
B	slows down	speeds up
C	stops immediately	speed stays constant
D	stops immediately	speeds up

- 10 160 g of alcohol is mixed with 500 cm^3 of water. The volume of the mixture becomes 690 cm^3 . If the density of water is 1.0 g/cm^3 , what is the density of the mixture?

A 0.49 g/cm^3
 B 0.72 g/cm^3
 C 0.96 g/cm^3
 D 1.05 g/cm^3

- 11 A can, filled with sand, is hung on a long string close to the surface of the Earth. An identical can is hung in the same way close to the surface of the Moon. The cans are given a sideways push.



Compared with the can hanging close to the Earth, the can close to the Moon starts to move

- A more easily, as it has less mass
 - B more easily, as it has less weight
 - C with the same ease, as it has the same mass
 - D with the same ease, as it has the same weight
- 12 The diagram shows a runner's shoe at the start of a race.
- Which arrow indicates the direction of the frictional force acting on the runner's shoe?

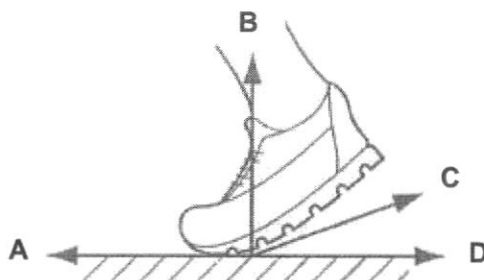

- 13 A piece of uniform card is suspended freely from a horizontal pin. Which point is its centre of mass?

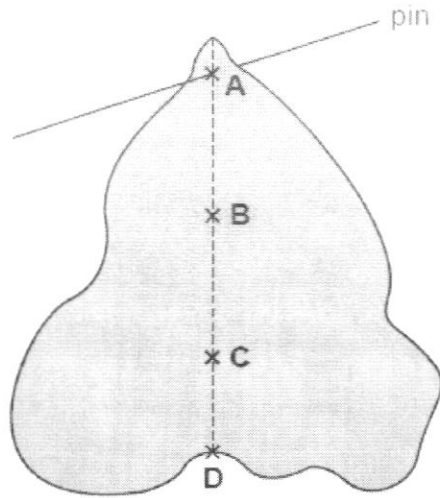

- 14 A wooden trapdoor is hinged along one side and, when closed, is supported on the other side by a ledge.

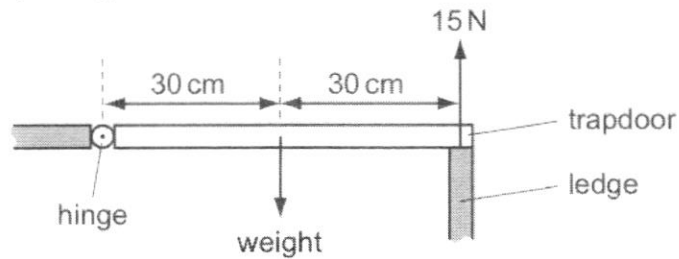

When the trapdoor is closed, the ledge exerts an upward force of 15 N on the trapdoor. The gravitational field strength is 10 N/kg.

What is the mass of the trapdoor?

- A 1.5 kg
- B 3.0 kg
- C 30 kg
- D 150 kg

- 15 Four students exercise in a gym. Which student does the most work?

	exercise time / s	power developed / W
A	50	250
B	100	150
C	200	200
D	250	30

- 16 Brownian motion can be observed under a microscope by observing fine pollen grains suspended in water. The random motion of one pollen grain is shown in the diagram below.



Which of the following best describes the random motion of pollen grains in water?

- A Pollen grains are moving because of convection current in the water.
- B Pollen grains are moving and colliding with one another.
- C Pollen grains are being hit by water molecules.
- D Pollen grains are living organisms moving around.
- 17 Two stones of mass 10 kg and 100 kg are released from rest at the same height above the ground. Neglecting the effects of air resistance, which of the following statements is correct ?
- A Both stones have the same initial gravitational potential energy.
- B Both stones will have the same speed when they reach the ground.
- C Both stones will have the same kinetic energy when they reach the ground.
- D Both stones will hit the ground with the same force.

- 18 An object of mass 30 kg is pulled up a slope of 15.0 m long. The frictional force between the object and the slope is 20 N.

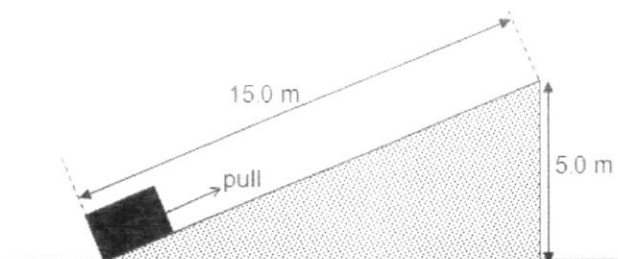

Assuming that the object does not gain any kinetic energy, what is the work done against friction?

- A 300 J
 B 1200 J
 C 1500 J
 D 1800 J
- 19 The height of a mercury barometer is h when the atmospheric pressure is 100 kPa.

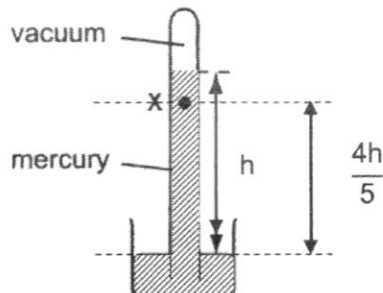

What is the pressure exerted at X indicated on the barometer?

- A 20 kPa
 B 80 kPa
 C 120 kPa
 D 180 kPa

- 20 The base for a statue rests on level ground. It is made from stone and is 2.0 m long, 2.5 m high and 0.80 m wide. It has a weight of 96 000 N.

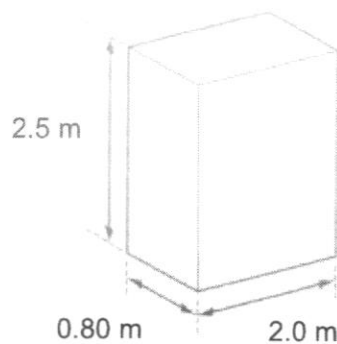

What is the pressure that the base exerts on the ground?

- A 19 kPa
 B 24 kPa
 C 48 kPa
 D 60 kPa
- 21 The diagram shows a hydraulic system. The cross-sectional area of the piston P is 8.0 cm^2 and the cross-sectional area of the piston Q is 12.0 cm^2 . The weight of the load placed on the piston Q is 60 N.

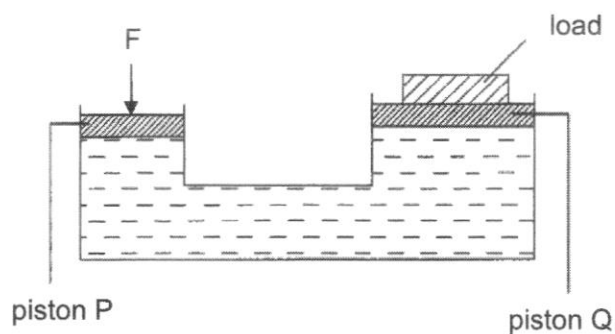

What is the force F required to hold the load at Q ?

- A 1.6 N
 B 40 N
 C 90 N
 D 5760

- 22 Ice is taken from a freezer and left in a room. The ice melts and eventually the water reaches room temperature.

Which of the following describes the net energy transfers?

	net energy transfer during melting	net energy transfer after melting
A	from ice to room	from water to room
B	from ice to room	from room to water
C	from room to ice	from room to water
D	from room to ice	from water to room

- 23 A beaker contains water at room temperature.

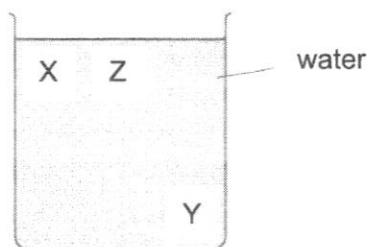

How could a convection current be set up in the water.

- A** cool the water at X
B cool the water at Y
C heat the water at X
D heat the water at Z
- 24 Visible light has wavelengths between 400 nm and 700 nm. What is the maximum frequency of visible light in vacuum?
- A** 1.2×10^{11} Hz
B 4.3×10^{11} Hz
C 4.3×10^{14} Hz
D 7.5×10^{14} Hz

- 25 The diagram shows a mercury-in-glass thermometer. The distance between the $-5\text{ }^{\circ}\text{C}$ and $105\text{ }^{\circ}\text{C}$ marking is 20 cm.

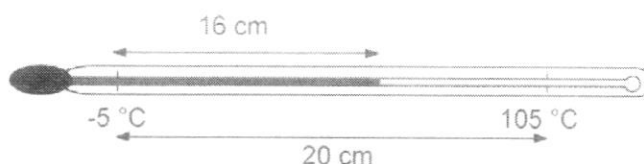

At which temperature is the end of the mercury thread 16 cm from the $-5\text{ }^{\circ}\text{C}$ mark?

- A $75\text{ }^{\circ}\text{C}$
 B $80\text{ }^{\circ}\text{C}$
 C $83\text{ }^{\circ}\text{C}$
 D $88\text{ }^{\circ}\text{C}$
- 26 The graph shows how the volume of 1 g of water varies between 273 K and 280 K.

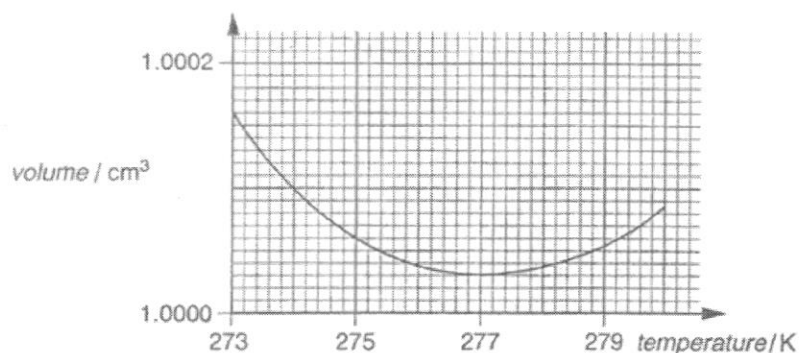

Why would a thermometer, based on the variation of the volume of a fixed mass of water, be unsuitable for measurements in this range?

- A The decrease in the volume over this range is greater than its increase.
 B The variation of volume is negligible over this range.
 C The variation of volume is non-linear over this range.
 D The variation of volume is not single-valued over this range.

27 The heating curve for 10 g of a substance is as shown.

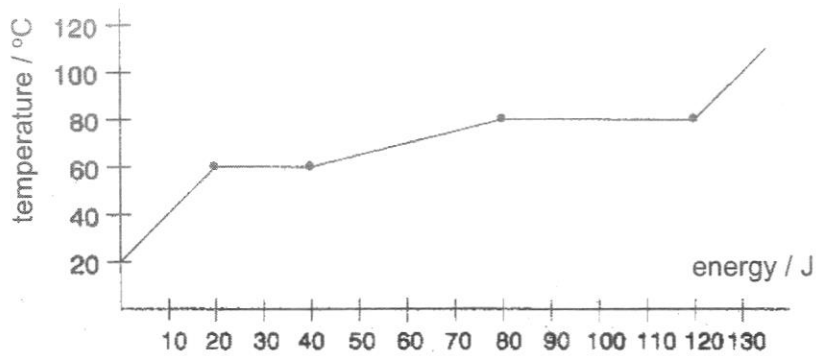

Which of the following statements is false?

- A The specific heat capacity of the liquid substance is 0.2 J/g°C.
 - B The specific heat capacity of the solid substance is 0.03 J/g°C.
 - C The specific latent heat of fusion is 2.0 J/g.
 - D The specific latent heat of vaporisation is 4.0 J/g.
- 28 The diagram shows a transverse wave on a rope. The wave is travelling to the right.

Which set of arrows correctly shows the direction of the velocities of points 1 and 2?

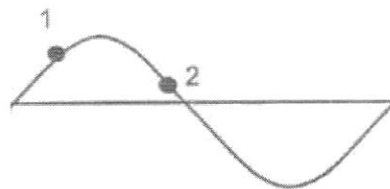

	Point 1	Point 2
A	→	→
B	→	←
C	↑	↓
D	↓	↑

- 29 Which of the following electromagnetic components has higher wavelength than green light?
- A infrared radiation
 - B violet light
 - C ultraviolet radiation
 - D gamma ray
- 30 The dipper in a ripple tank vibrates at a frequency of 4.0 Hz and the resulting wave pattern is photographed.

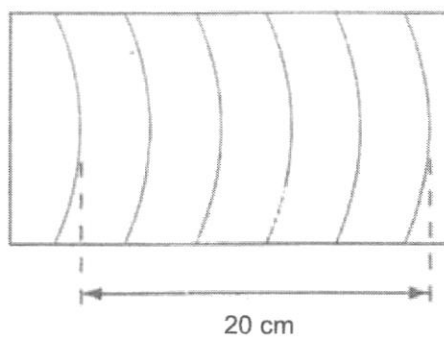

What is the speed of the wave?

- A 4 cm/s
- B 5 cm/s
- C 16 cm/s
- D 80 cm/s

End of Paper

Name: _____	Class	Index Number
	_____	_____



Jurong West Secondary School
End-of-Year Examinations 2022

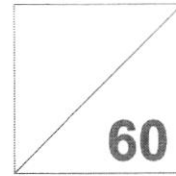

PHYSICS

6091/02

Secondary Three Express

Tuesday, 4 October 2022

Paper 2

0800 – 0920

1 hour 20 minutes

Candidates answer on the Question Paper.

READ THESE INSTRUCTIONS FIRST

Write your name, class and index number on all the work you hand in.

Write in dark blue or black pen.

You may use an HB pencil for any diagrams, graphs, tables or rough working.

Do not use staples, paper clips, glue or correction fluid.

The use of an approved scientific calculator is expected, where appropriate.

You may lose marks if you do not show your working or if you do not use appropriate units.

Section A

Answer **all** questions in the spaces provided.

Section B

Answer **all** questions in the spaces provided. Question 10 has a choice of parts to answer.

Candidates are reminded that **all** quantitative answers should include appropriate units.

The use of an approved scientific calculator is expected, where appropriate.

Candidates are advised to show all their working in a clear and orderly manner, as more marks are awarded for sound use of Physics than for correct answers.

The number of marks is given in brackets [] at the end of each question or part question.

After checking of answer script		
Checked by Student	Signature	Date

There are a total of **18** printed pages (including the cover page)

Section A (40 marks)

Answer **all** the questions in this section in the spaces provided.

- 1 A micrometer screw gauge is used to measure the diameter of a piece of pencil lead. Fig. 1.1 shows the main and thimble scales of the micrometer screw gauge when its spindle and anvil is fully closed.

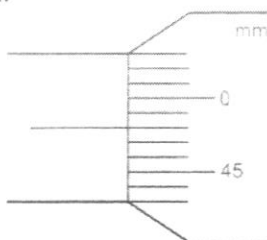

Fig. 1.1

- (a) Fig. 1.2 shows the main and thimble scales of the micrometer screw gauge when the micrometer is used to measure the diameter of the piece of pencil lead.

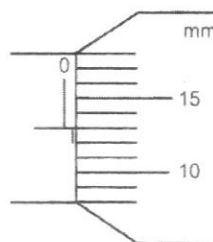

Fig. 1.2

Determine the actual reading of the diameter of the pencil lead? Show your working clearly.

actual reading of diameter = [3]

- (b) Realising the micrometer has zero error, a student recorded multiple readings of the diameter of the same piece of pencil lead, and take the average reading as the measurement of the diameter of the pencil lead. He claims that by doing so, he can minimise the zero error.

Explain why this claim is incorrect.

.....
 [1]

- 2 Fig. 2.1 shows a toy car pulled by two boys across a rough surface. The toy car move with a constant velocity.

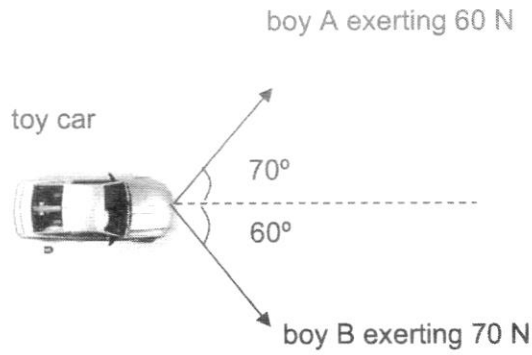

Fig. 2.1 (diagram not drawn to scale)

By means of a scaled diagram, determine the magnitude and direction of the frictional force acting on the toy car.

direction of frictional force =

magnitude of frictional force = [4]

- 3 A rocket of mass 75 000 kg is launched from the surface of an unknown planet W. Fig 3.1 shows the motion of the rocket. After launch, the rocket's engine is cut off after 18 s. It reaches a maximum height at 50 s. The rocket falls to the ground 90 s after the launch.

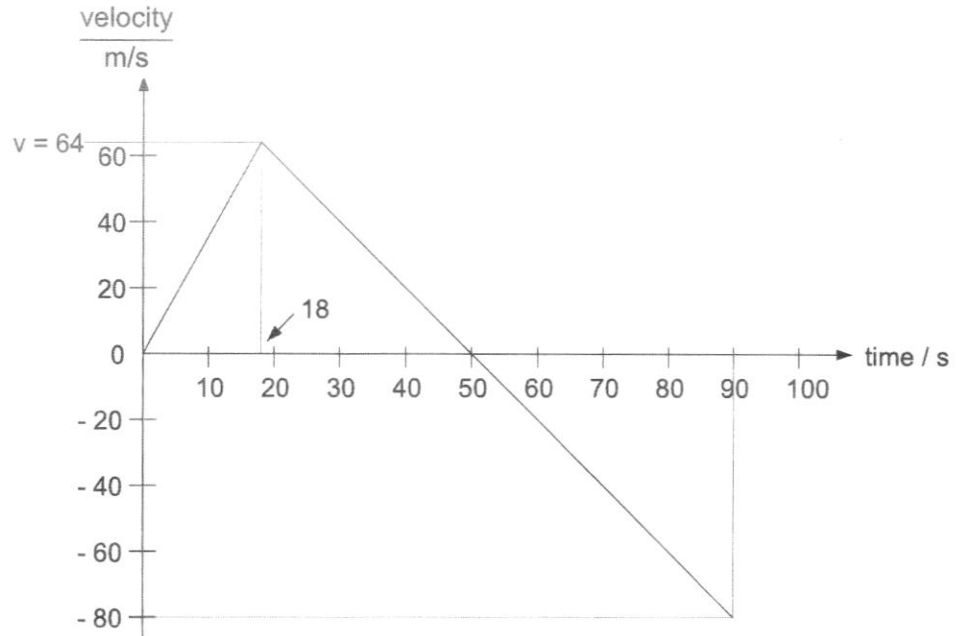

Fig. 3.1

- (a) Describe the motion of the rocket from time $t = 0$ s to $t = 90$ s. State clearly the direction of motion.

.....

.....

.....

.....

..... [3]

- (b) Calculate the acceleration of free fall on planet W.

acceleration of free fall on planet W = [2]

- (c) In the space below, sketch a graph to show the displacement of the rocket with respect to the ground from $t = 0$ s to $t = 90$ s. Label all critical values of displacement. [3]

- 4 In an experiment, a metal pellet was fired from an air rifle towards a 8.0 kg block of plastic suspended from the top of a ceiling. The initial position of the block is shown in Fig. 4.1. When the pellet hits the plastic block, the pellet penetrates the block and the block is displaced as shown in Fig. 4.2.

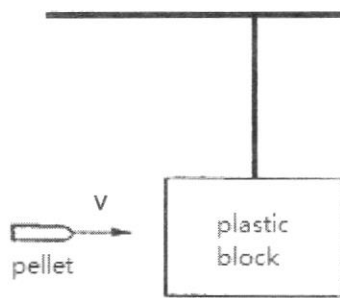

BEFORE

Fig. 4.1

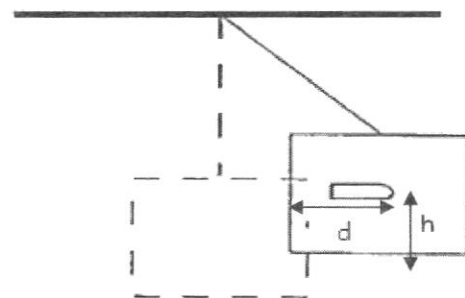

AFTER

Fig. 4.2

Some data collected from the experiment can be found in Table 4.1.

Table 4.1

mass of pellet	speed of pellet before impact	depth of penetration, d	time for pellet to stop	increase in height of plastic block, h
0.050 kg	40 m/s	0.15 m	0.026 s	0.348 m

- (a) Calculate the kinetic energy of the pellet just before it hits the plastic block.

kinetic energy =[2]

- (b) An average frictional force of 70 N acts on the pellet when it is moving inside the plastic block. Calculate the work done by the pellet against friction.

work done against friction =[2]

- (c) Using values obtained in (a), (b) as well as data obtained in Table 4.1, show that there is a discrepancy between experimental and theoretical values for the increase in height of the plastic block. You may assume that the data in Table 4.1 were measured accurately.

Suggest a reason for the discrepancy.

.....

 [3]

5 Fig. 5.1 shows a tap with a long handle.



Fig. 5.1

(a) Define the term moment of a force.

.....
..... [1]

(b) Explain why having a long tap handle is useful in turning the tap on.

.....
..... [1]

(c) The minimum moment of force required to turn on the tap is 0.40 N m and that the tap handle has a length of 18 cm.

Calculate the minimum force required to turn on the tap.

minimum force =[2]

- 6 An engineer wishes to check the volume of air inside a pipe and to check that the pipe is not leaking. He connects a syringe to one end of the pipe and a manometer to the other end, as shown in Fig. 6.1.

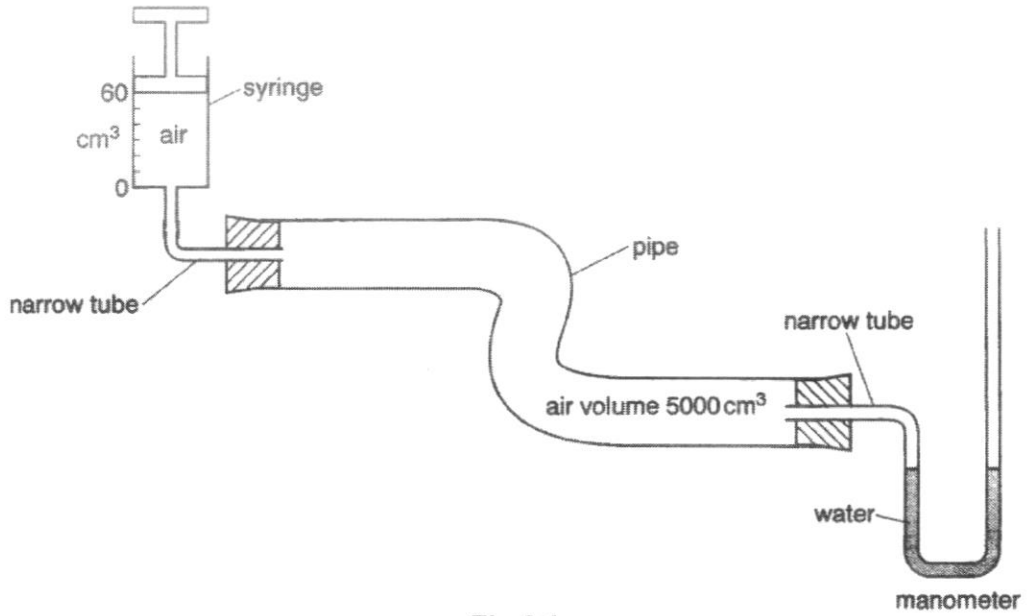

Fig.6.1

The syringe initially contains 60 cm³ of air and the pipe contains 5000 cm³ of air. The volume of the narrow tubes may be neglected. All the air is initially at atmospheric pressure, 1.0 x 10⁵ Pa.

- (a) The piston of the syringe is pushed fully down and held steady.

Explain, in terms of molecules, why the pressure of the air inside the pipe increases when the piston in the syringe is pushed down.

.....

.....

.....

..... [2]

- (b) Calculate the pressure of air inside the pipe after the piston of the syringe is fully pushed down.

pressure = [2]

- (c) After piston of the syringe is pressed down fully, the manometer containing water connected to the pipe with the new water levels is shown in Fig. 6.2. The difference in the water levels in both tubes of the manometer is denoted by h .

The atmospheric pressure is 1.00×10^5 Pa and the density of water is 1000 kg/m^3 .

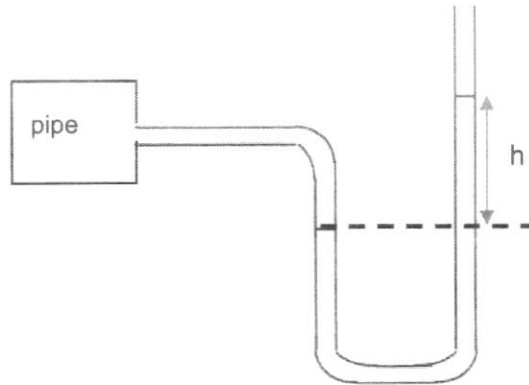

Fig.6.2

Calculate the height h .

$$h = \dots\dots\dots[2]$$

- 7 Fig. 7.1 shows a wave travelling along a rope towards the right. The positions of the wave at the time intervals $t = 0$ s and $t = 2$ s are shown.

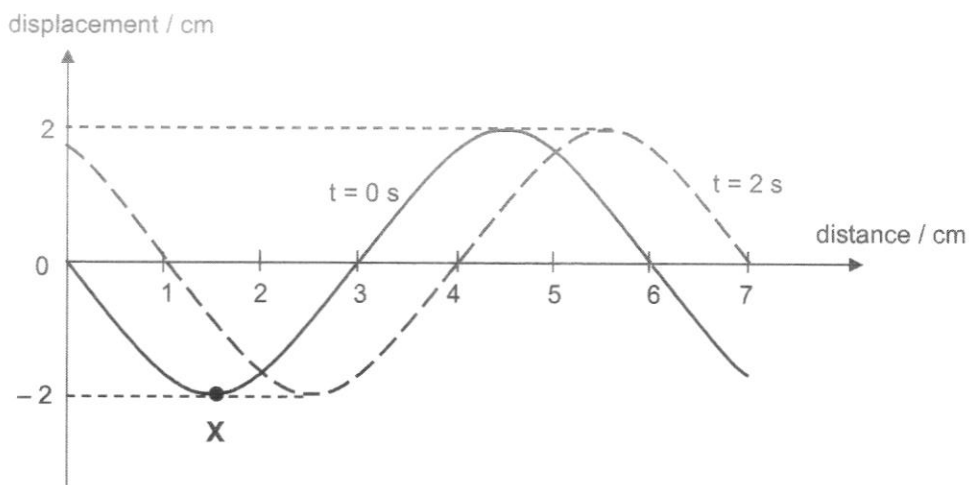

Fig. 7.1

- (a) Define the term period for a wave.

.....
 [1]

- (b) State the wavelength of the wave.

wavelength = [1]

- (c) Calculate the speed of the wave as it moves towards the right.

speed = [2]

- (d) X is a particle on the wave at $t = 0$ s. On Fig. 7.1, mark the position of X at $t = 6$ s. Label this position as W. [1]

- 8 The boiling tube is heated at the indicated position as shown in Fig. 8.1. After some time, water near the heated area starts to boil, while some ice cubes still remain without melting completely.

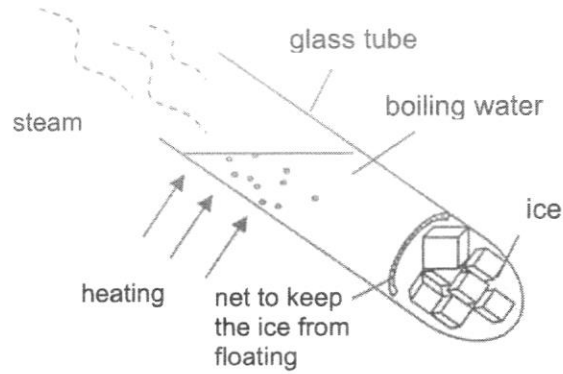

Fig.8.1

Using knowledge about heat transfer, explain how this is possible.

.....

.....

.....

.....

..... [2]

Section B (20 marks)

Answer **all** the questions in this section.

Answer only one of the two alternative questions in Question 10.

- 9 On a straight road, a 40 000 kg truck accelerates from rest and reaches its maximum speed after travelling 3.0 km. Fig. 9.1 shows how the resultant force F acting on the truck varies with the distance d it has travelled.

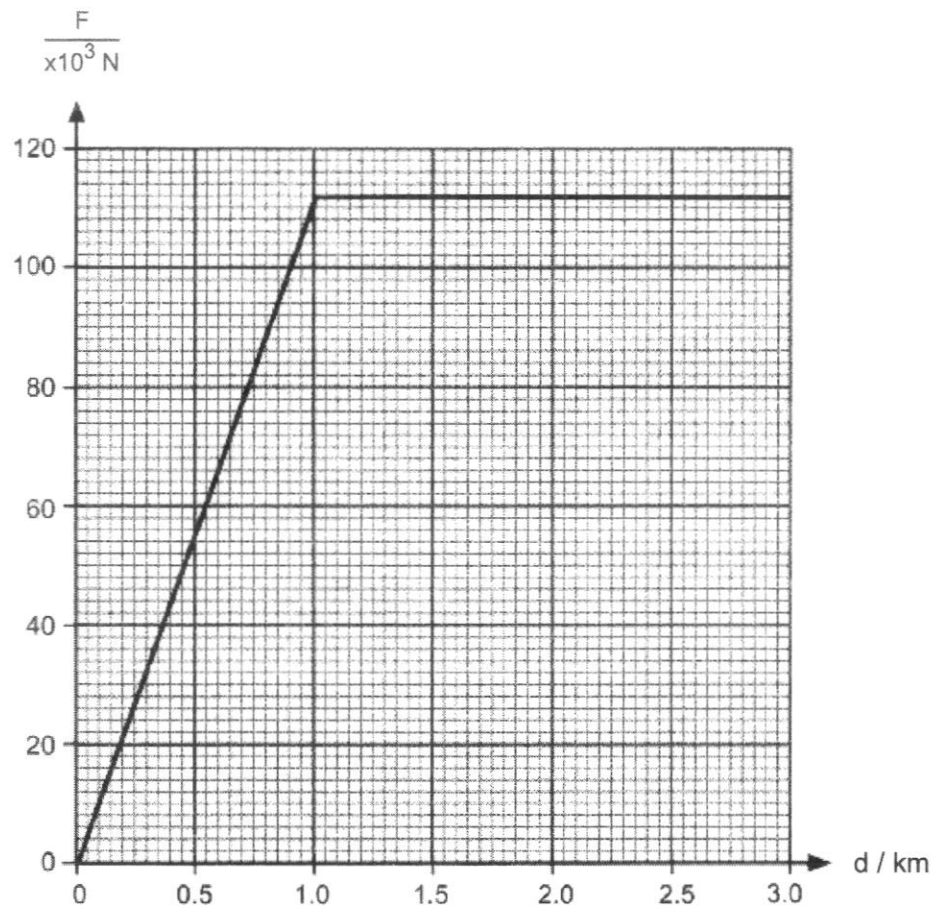

Fig. 9.1

- (a) With reference to Fig. 9.1, identify the part of the journey when the acceleration of the truck is non-uniform. Explain your answer.

.....

 [2]

- (b) Calculate the acceleration of the truck when the acceleration is uniform.

acceleration =[2]

- (c) Fig. 9.2 shows the truck. The front wheel of the truck is turned clockwise direction by the engine as the truck accelerates.

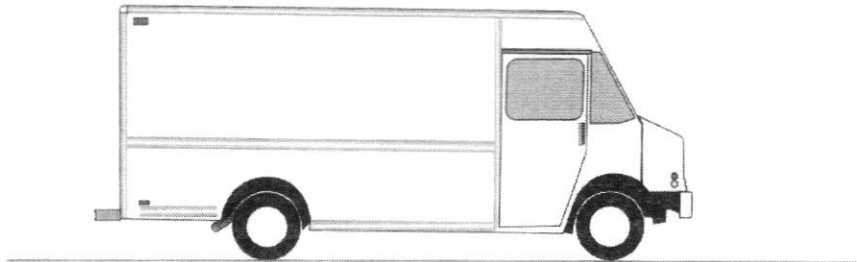

Fig.9.2

On Fig 9.2, draw using arrows, the frictional forces acting on the front and rear wheels of the truck by the ground. [2]

- (d) The overall frictional forces opposing the motion of the truck for the entire journey is 10 kN.
 - (i) State the driving force of the truck when the truck was travelling between 1 to 3 km.

driving force = [1]

- (ii) Calculate the work done by the driving force when the truck was travelling between 1 to 3 km.

work done = [2]

- (iii) Suggest how the work done by the driving force can be obtained in the first 1 km of the truck's journey.

.....
..... [1]

10 EITHER

Fig. 10.1 shows part of a heating curve of an unknown solid. The mass of this solid is 25 g and it was heated using a 30 W heater.

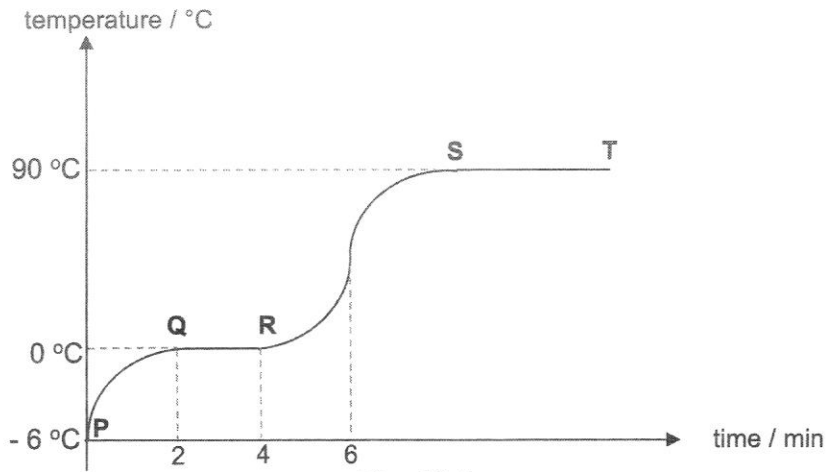

Fig. 10.1

(a) Indicate the state(s) of matter in sections **RS** and **ST** of the graph.

RS = [1]

ST = [1]

(b) Describe the change in motion and the intermolecular distance between the particles in

(i) section PQ.

.....

.....

.....

.....

..... [2]

(ii) section ST.

.....

 [2]

(c) The unknown solid was placed into a container and heated with the 30 W heater for 6 minutes.

(i) Calculate the total amount of heat provided by the heater in 6 minutes.

total amount of heat = [1]

(ii) Using information from Fig. 10.1, determine the final temperature of the substance after 6 minutes of heating. The specific heat capacity of substance between RS is 3 800 J / kg°C.

final temperature = [2]

(d) State one assumption made when calculating **c(ii)**.

.....
 [1]

10 OR

Fig. 10.2 shows a fire alarm in a school.

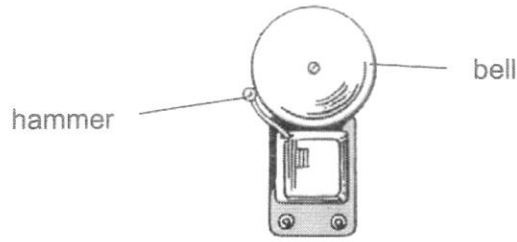

Fig. 10.2

(a) Describe, using ideas of molecules, how the sound travels from the bell to different parts of the school.

.....

.....

.....

.....

..... [3]

(b) Fig. 10.3 shows a man standing at a distance from the fire alarm.

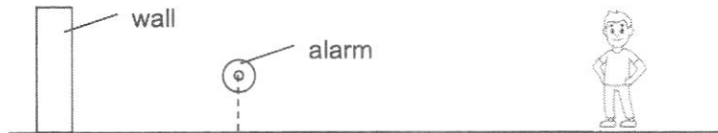

Fig. 10.3

The fire alarm sounds for a split second and then switches off.
 The man hears two sounds, one directly from the alarm and the other is an echo. The time interval between these two sounds is 1.5 s. The speed of sound in air is 330 m/s.

Calculate the distance between the alarm and the wall.

distance = [2]

- (c) If the frequency of the sound is 50 Hz, calculate the wavelength of the sound.

wavelength = [1]

- (d) The man observes that the loudness of the echo is softer than the sound that he hears directly from the alarm. Suggest two possible reasons for this observation.

.....

 [2]

- (e) The alarm is replaced by another alarm that makes sounds that are softer and of a lower pitch. Fig. 10.4 shows a graph of air pressure against time for the sound wave of the previous alarm.

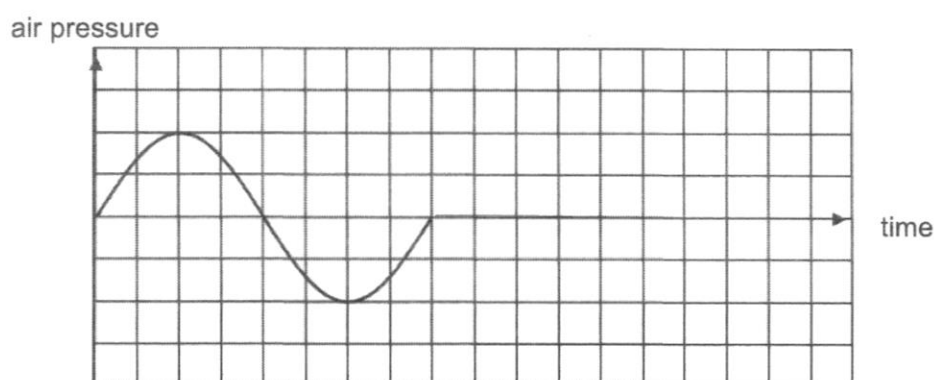

Fig. 10.4

On Fig. 10.4, sketch a graph of air pressure against time for the sound wave from the new alarm. [2]

END OF PAPER



Jurong West Secondary School
End-of-Year Examinations 2022

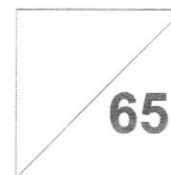

PHYSICS

Secondary Three Express

Paper 2

6091/01 & 02

October 2022

1130 – 1315

1 hour 20 minutes

Candidates answer on the Question Paper.

MARKING SCHEME

/ ANSWER KEY

Instructions to Markers (if any)

The number of marks is given in brackets [] at the end of each question or part question.

Jurong West Secondary School
End-of-Year Examinations 2022
Mark Scheme

Secondary Three Express

SCIENCE (PHYSICS) 6091/01 & 02

PAPER 1

1	2	3	4	5	6	7	8	9	10
B	D	B	A	B	A	C	A	B	C
11	12	13	14	15	16	17	18	19	20
C	A	C	B	C	C	B	A	A	D
21	22	23	24	25	26	27	28	29	30
B	C	A	D	C	C	B	D	A	C

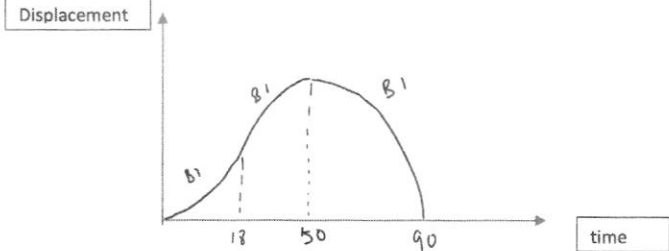
<p>3a</p>	<p>From 0 to 18 s, the rocket is moving upwards with uniform acceleration; From 18 to 50 s, the rocket is still moving upwards but with uniform deceleration; From 50 to 90 s, the rocket is moving downwards with uniform acceleration;</p>	<p>B1 B1 B1</p>	
<p>b</p>	<p>$a = (v - u)/t$ $= (0 - 64)/(50 - 18)$ $= - 2.0 \text{ m/s}^2$</p> <p>Acceleration of free fall = 2 m/s^2</p>	<p>M1 A1</p>	
<p>c</p>		<p>1 mk for ea part</p>	
<p>4a</p>	<p>$KE = 0.5mv^2$ $= 0.5 \times 0.050 \times 40^2$ $= 40 \text{ J}$</p>	<p>M1 A1</p>	

b	Work Done = $F \times d$ $= 70 \times 0.15$ $= 10.5 \text{ J}$	M1 A1	
c	KE lost = Work against friction + Gain in GPE $40 = 10.5 + mgh$ $40 = 10.5 + 8 \times 10 \times h$ $h = 0.369 \text{ m}$ The theoretical height gain is greater than that measured. This implies that there are other energy losses that were not accounted for such as those lost due to air resistance acting on the block .	B1 B1 B1	
5a	Moment is defined as the product of the force and the perpendicular distance from the line of action of the force to the pivot ;	B1	
b	The long tap handle increases the perpendicular distance between the force and the pivot. This allows a greater moment to be generated with a smaller force;	B1	
c	Moment = force \times distance $0.4 = F \times 0.18$ $F = 2.22 \text{ N}$	M1 A1	
6a	When the piston of the syringe is pressed down, the number of molecules per unit volume in the pipe increases ; This resulted in the frequency of collision between the air molecules and the walls of the pipe to increase , leading to a greater force exerted per unit area;	B1 B1	
b	$P_1 V_1 = P_2 V_2$ $1 \times 10^5 \times (5000 + 60) = P_2 \times 5000$ $P_2 = 1.01 \times 10^5 \text{ Pa}$	M1 A1	

c	$P_2 = P_{\text{atm}} + P_{h_2o}$ $1.01 \times 10^5 = 1.0 \times 10^5 + P_{h_2o}$ $P_{h_2o} = 1200 \text{ Pa}$ $P = h\rho g$ $1200 = h \times 1000 \times 10$ $h = 0.12 \text{ m}$	M1 A1	
7a	Period is the time taken to produce one complete wave OR Period is the time taken for one complete wave to pass through a point	B1	
b	6 cm	A1	
c	$\text{Speed} = \text{Distance} / \text{time}$ $= \frac{1}{2}$ $= 0.50 \text{ cm/s} \text{ or } 5.0 \times 10^{-3} \text{ m/s}$	M1 A1	
d		B1	
8	Heat gained from the heat source causes water to be less dense and rise . Convection current is formed above the heat source heats up the water causing it to boil quickly;	B1	

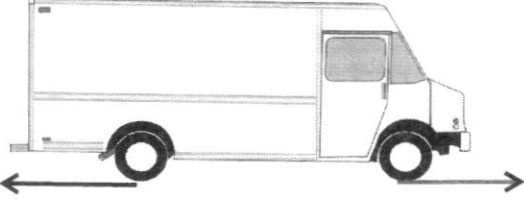
	The water below the heat source could only transfer heat through conduction . Since water is a poor conductor of heat, it takes a much longer time for heat from the source to reach the ice and melt it;		
9a	0 to 1 km; The resultant force of the truck was increasing from 0 to 112 kN. Since acceleration is proportional to resultant force, acceleration must be increasing	B1 B1	A: Accept any indication that the range is 0 to 1
b	$F = ma$ $102\,000 = 40\,000 \times a$ $a = 2.55 \text{ m/s}^2$	M1 A1	
c		BT ea	
di	Driving force = $112 + 10 = 122 \text{ kN}$	A1	
dii	Work Done = $F \times d$ $= 112\,000 \times 2000$ $= 2.24 \times 10^8 \text{ J}$	M1 A1	
e	Work done by driving force = work done by resultant force + Work done against friction. Work done by resultant force can be found from the area under the graph for 0 to 1km, while work done against friction = Frictional force x distance;	B1	

10a	RS: Liquid; ST: Liquid & Gas;	B1 B1	
bi	Particles vibrate more vigorously about their fixed position; Intermolecular distance increases slightly as the substance expand;	B1 B1	R: vibrate vigorously (suggest particles not moving initially)
bii	Particles' motion changes from sliding over on another to move about at high speed ; Particles' intermolecular distance changes from closely packed to very far apart ;	B1 B1	
ci	$E = P \times t$ $= 30 \times 6 \times 60$ $= 10\,800 \text{ J}$	A1	
cii	$Q = mc\theta$ $30 \times 2 \times 60 = 0.025 \times 3800 \times \theta$ $\theta = 37.9^\circ\text{C}$ final temp = 37.9°C	M1 A1	
d	No heat lost to surrounding;	B1	
10 O a	When the hammer hits the bell, the bell vibrates ; Vibrating bell causes the air molecules around it to vibrate parallel to the direction of the energy transfer . Vibrating air molecules collide into neighbouring air particles transferring energy causing other air molecules to vibrate as well; This forms a series of compressions and rarefactions transmitting sound energy to different parts of the school;	B1 B1 B1	R: molecules (no mention of which one)
b	Diff in distance b/w the 2 sounds = Speed x time $= 330 \times 1.5$ $= 495 \text{ m}$ Dist b/w wll and bell = $495/2 = 247.5 = 248 \text{ m}$	M1 A1	

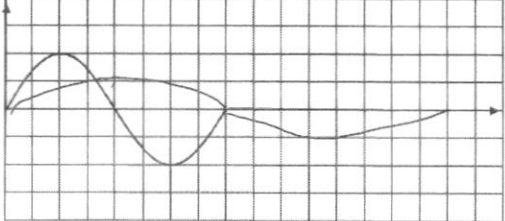
c	$V = f\lambda$ $330 = 50 \lambda$ $\lambda = 6.6 \text{ m}$	A1	
d	<p>Energy was lost/ absorbed during the transmission of sound through air as well as when sound reflects off the wall;</p> <p>During reflection, not all of the sound energy would be directed towards the man;</p>	B1 B1	
e		B1 ea	