

*Visit*

**FREETESTPAPER.com**

*for more papers*



Website: [freetestpaper.com](http://www.freetestpaper.com)



[Facebook.com/freetestpaper](https://www.facebook.com/freetestpaper)



[Twitter.com/freetestpaper](https://www.twitter.com/freetestpaper)



**COMMONWEALTH SECONDARY SCHOOL  
PRELIMINARY EXAMINATION 2018**

**ADDITIONAL MATHEMATICS  
PAPER 1**

Name: \_\_\_\_\_ (        )        Class: \_\_\_\_\_

---

**SECONDARY FOUR EXPRESS  
SECONDARY FIVE NORMAL ACADEMIC  
4047/1**

**Wednesday 12 September 2018  
11 00 – 13 00  
2 h**

---

**READ THESE INSTRUCTIONS FIRST**

Write your name, index number and class on all the work you hand in.

Write in dark blue or black pen on both sides of the paper.

You may use a soft pencil for any diagrams or graphs.

Do not use staples, paper clips, highlighters, glue or correction fluid.

Answer **all** the questions.

Write your answers on the separate writing paper provided.

Give non-exact numerical answers correct to 3 significant figures, or 1 decimal place in the case of angles in degrees, unless a different level of accuracy is specified in the question.

The use of an approved scientific calculator is expected, where appropriate.

You are reminded of the need for clear presentation in your answers.

At the end of the examination, fasten all your work securely together.

The number of marks is given in brackets [ ] at the end of each question or part question.

The total number of marks for this paper is 80.

**Name of setter: Mrs Margaret Loh**

---

This paper consists of 7 printed pages including the cover page.

[Turn over

**Mathematical Formulae****1. ALGEBRA***Quadratic Equation*

For the equation  $ax^2 + bx + c = 0$ ,

$$x = \frac{-b \pm \sqrt{b^2 - 4ac}}{2a}.$$

*Binomial expansion*

$$(a + b)^n = a^n + \binom{n}{1} a^{n-1} b + \binom{n}{2} a^{n-2} b^2 + \dots + \binom{n}{r} a^{n-r} b^r + \dots + b^n,$$

where  $n$  is a positive integer and  $\binom{n}{r} = \frac{n!}{r!(n-r)!} = \frac{n(n-1)\dots(n-r+1)}{r!}$

**2. TRIGONOMETRY***Identities*

$$\sin^2 A + \cos^2 A = 1$$

$$\sec^2 A = 1 + \tan^2 A$$

$$\operatorname{cosec}^2 A = 1 + \cot^2 A$$

$$\sin(A \pm B) = \sin A \cos B \pm \cos A \sin B$$

$$\cos(A \pm B) = \cos A \cos B \mp \sin A \sin B$$

$$\tan(A \pm B) = \frac{\tan A \pm \tan B}{1 \mp \tan A \tan B}$$

$$\sin 2A = 2 \sin A \cos A$$

$$\cos 2A = \cos^2 A - \sin^2 A = 2 \cos^2 A - 1 = 1 - 2 \sin^2 A$$

$$\tan 2A = \frac{2 \tan A}{1 - \tan^2 A}$$

*Formulae for  $\Delta ABC$* 

$$\frac{a}{\sin A} = \frac{b}{\sin B} = \frac{c}{\sin C}$$

$$a^2 = b^2 + c^2 - 2bc \cos A$$

$$\Delta = \frac{1}{2} bc \sin A$$

1. The slope at any point  $(x, y)$  of a curve is given by  $\frac{dy}{dx} = \frac{k}{(2x+3)^2} - 1$  where  $k$  is a constant. If the tangent to the curve at  $(-1, 0)$  is perpendicular to the line  $3y = x + 1$ , find
- the value of  $k$ , [3]
  - the equation of the curve. [3]
2. (i) On the same axes, sketch the curves  $y = -8x^{-\frac{1}{2}}$  and  $y^2 = \frac{1}{4}x$ . [2]
- (ii) Find the equation of the line passing through the origin and the point of intersection of the two curves. [3]
3. The equation  $y = \frac{x+c}{x+d}$ , where  $c$  and  $d$  are constants, can be represented by a straight line when  $xy - x$  is plotted against  $y$ . The line passes through the points  $(0, 4)$  and  $(0.2, 0)$ .
- Find the value of  $c$  and of  $d$ , [4]
  - If  $(2.5, a)$  is a point on the straight line, find the value of  $a$ . [1]
4. The roots of a quadratic equation are  $\alpha$  and  $\beta$ , where  $\alpha^3 + \beta^3 = 0$ ,  $\alpha\beta = \frac{27}{64}$ ,  $\alpha + \beta > 0$ .
- Find this quadratic equation with integral coefficient. [4]
- The roots of another quadratic equation  $x^2 + px + q = 0$  are  $\alpha - \beta$  and  $\beta - \alpha$ .
- Find the value of  $p$  and of  $q$ . [3]
5. (i) Prove the identity  $\sin^2 2x(\cot^2 x - \tan^2 x) = 4 \cos 2x$ . [4]
- (ii) Hence find, for  $0 \leq x \leq 2\pi$ , the values of  $x$  for which  $\sin^2 2x = \frac{e}{\cot^2 x - \tan^2 x}$ . [3]

6.

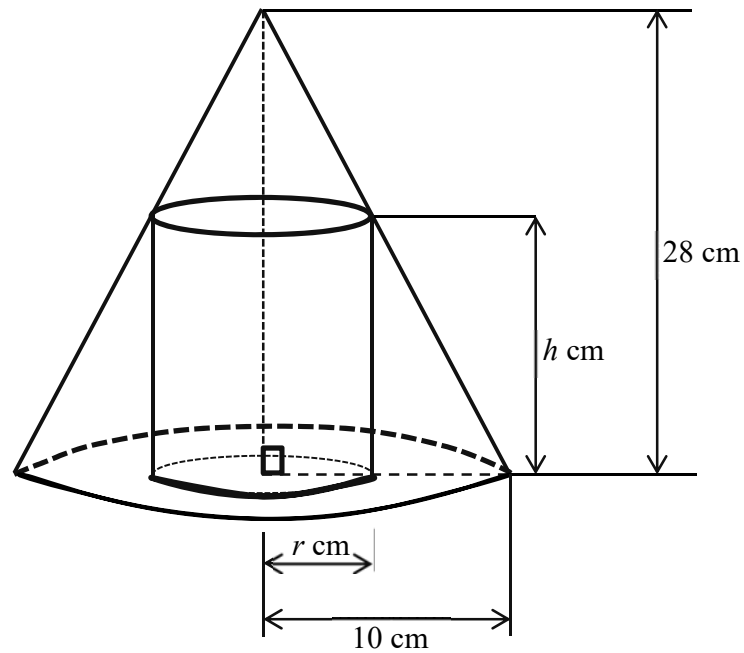

(a) The diagram shows a cylinder of height  $h$  cm and base radius  $r$  cm inscribed in a cone of height 28 cm and base radius 10 cm. Show that

(i) the height,  $h$  cm, of the cylinder is given by

$$h = 28 - \frac{14}{5}r. \quad [1]$$

(ii) the volume,  $V$  cm<sup>3</sup>, of the cylinder is given by

$$V = 14\pi r^2 \left(2 - \frac{r}{5}\right). \quad [1]$$

(b) (i) Given that  $r$  can vary, find the maximum volume of the cylinder. [5]

(ii) Show that, in this case, the cylinder occupies  $\frac{4}{9}$  of the volume of the cone. [2]

7. (a) A circle with centre  $P$  lies in the first quadrant of the Cartesian plane. It is tangential to the  $x$ -axis and the  $y$ -axis, and passes through the points  $A(4, 18)$  and  $B(18, 16)$ .

Find

- (i) the equation of the perpendicular bisector of the line segment  $AB$ , [3]  
 (ii) the coordinates of the centre  $P$ , [2]  
 (iii) the equation of the circle, [1]

The tangent at  $A$  touches the  $x$ -axis at  $R$ . The line joining  $A$  and  $P$  is produced to touch the  $x$ -axis at  $S$ .

- (b) Find the area of triangle  $ARS$ . [4]

8. Use the result  $(\sqrt{x} + \sqrt{y})^2 \equiv x + y + 2\sqrt{xy}$ , or otherwise, find the square root of  $12 + \sqrt{140}$  in the form  $\sqrt{a} + \sqrt{b}$ , where  $a$  and  $b$  are constants to be determined. [5]

9. Given that  $P(x) = 2x^4 - 5x^3 + 5x^2 - x - 10$ ,

- (i) find the quotient when  $P(x)$  is divided by  $(2x - 1)(x^2 + 3)$ , [2]  
 (ii) hence express  $\frac{P(x)}{(2x - 1)(x^2 + 3)}$  in partial fractions. [5]

10. The velocity,  $v \text{ ms}^{-1}$ , of a particle travelling in a straight line at time  $t$  seconds after leaving a fixed point  $O$ , is given by

$$v = 2t^2 + (1 - 3k)t + 8k - 1,$$

where  $k$  is a constant. The velocity is a minimum at  $t = 5$ .

- (i) Show that  $k = 7$ . [2]  
 (ii) Show that the particle will never return to  $O$  with time. [2]  
 (iii) Find the duration when its velocity is less than  $13 \text{ ms}^{-1}$ . [2]  
 (iv) Find the distance travelled by the particle during the third second. [2]

11.

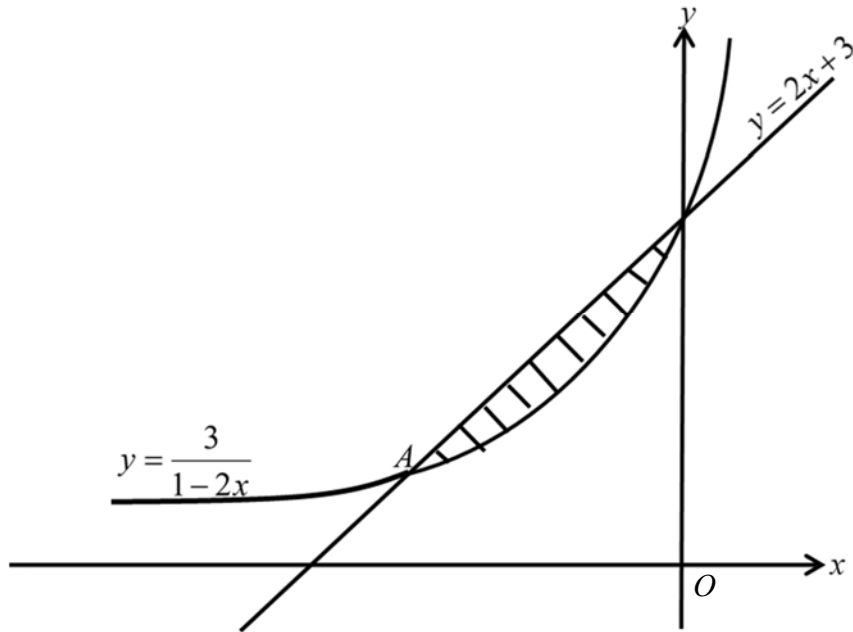

The diagram shows part of curve  $y = \frac{3}{1-2x}$  intersecting with a straight line

$y = 2x + 3$  at the point  $A$ . Find

- (i) the coordinates of  $A$ . [2]
- (ii) the area of the shaded region bounded by the line and the curve. [4]

12.

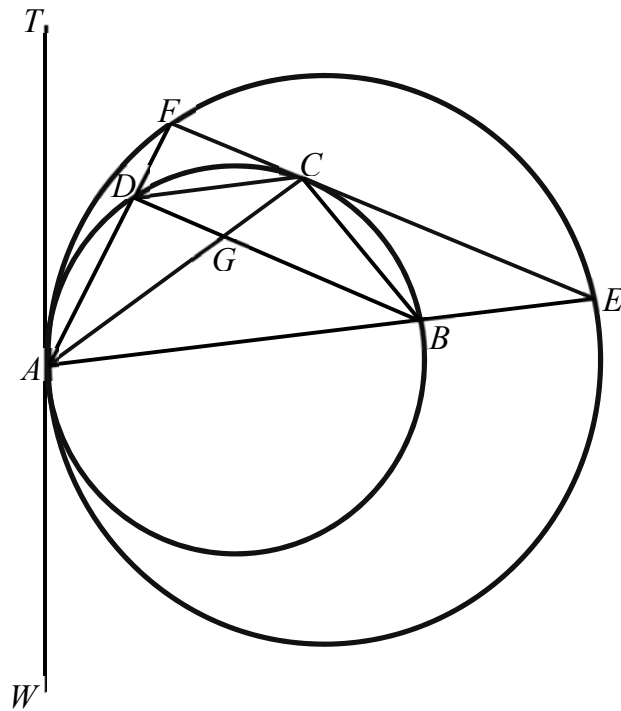

In the diagram, two circles touch each other at  $A$ .  $TA$  is tangent to both circles at  $A$  and  $FE$  is a tangent to the smaller circle at  $C$ . Chords  $AE$  and  $AF$  intersect the smaller circle at  $B$  and  $D$  respectively. Prove that

- (i) line  $BD$  is parallel to line  $FE$ , [2]
- (ii)  $\angle FAC = \angle CAE$ , [3]

END OF PAPER

2018 CWSS Prelim AM P1 Answer Key

1.	(i) $-2$ (ii) $y = \frac{1}{(2x+3)} - x - 2$	10.	(iii) $4s$ (iv) $17\frac{2}{3}$ m or $17.7$ m
2.	(ii) $y = -\frac{1}{8}x$	11.	(i) $A = (-1,1)$ (ii) $0.352$ units <sup>2</sup>
3.	(i) $c = 4$ ; $d = 20$ (ii) $-46$	12.	(i) <u>To prove:</u> $BD \parallel FE$ <u>Proof:</u> Let $\angle TAF$ be $\theta$ . $\angle ABD = \angle TAF = \theta$ (alt seg thm) $\angle AEF = \angle TAF = \theta$ (alt seg thm) $\therefore \angle ABD = \angle AEF = \theta$
4.	(i) $64x^2 - 72x + 27 = 0$ (ii) $p = 0$ ; $q = \frac{27}{64}$		Using property of corresponding angles, $BD \parallel EF$ (shown)
5.	(ii) $0.412, 2.73, 3.55, 5.87$		(ii) <u>To prove:</u> $\angle FAC = \angle CAE$ <u>Proof:</u> Let $\angle BCE = \alpha$ $\angle CBD = \angle BCE = \alpha$ (alt $\angle$ s, $BD \parallel EF$ ) $\angle FAC = \angle CBD = \alpha$ ( $\angle$ s in same segment) Also, $\angle CAE = \angle BCE = \alpha$ (alt seg thm) $\therefore \angle FAC = \angle CAE = \alpha$ (shown)
6.	b(i) $\frac{11200\pi}{27} \text{ cm}^3$ or $1300 \text{ cm}^3$		
7.	a(i) $y = 7x - 60$ (ii) $(10, 10)$ (iii) $(x-10)^2 + (y-10)^2 = 100$ b. $337.5$ units <sup>2</sup>		
8.	$\sqrt{7} + \sqrt{5}$		
9.	(i) $x - 2$ (ii) $x - 2 - \frac{3}{(2x-1)} + \frac{7}{(x^2+3)}$		

END

CWSS 2018 AM Prelim P1 Marking Scheme

Qn No	Solutions	Marks
1	$3y = x + 1$	
	$y = \frac{1}{3}x + \frac{1}{3}$	
	$\therefore$ grad of tangent = $-3$	M1
(i)	$-3 = \frac{k}{(2x+3)^2} - 1$	M1
	$k = -2$	A1
(ii)	$\frac{dy}{dx} = \frac{-2}{(2x+1)^2} - 1$	
	$y = \int [-2(2x+1)^{-2} - 1] dx$	M1
	$= \frac{-2(2x+1)^{-1}}{(-1)(2)} - x + c$	
	$= \frac{1}{(2x+3)} - x + c$	M1
	When $y = 0$ , $x = -1$	
	$0 = \frac{1}{-2+3} + 1 + c$	
	$c = -2$	
	$\therefore y = \frac{1}{(2x+3)} - x - 2$	A1
2(i)		Graphs are [B1] & [B1]
(ii)	$(-8x^{\frac{1}{2}})^2 = \frac{1}{4}x$	M1
	$64x^{-1} = \frac{1}{4}x$	
	$256 = x^2$	
	$x = 16$ or $-16$ (NA)	M1
	When $x = 16$ , $y = \frac{-8}{\sqrt{16}} = -2$	

	Grad of line = $\frac{-2}{16} = -\frac{1}{8}$	
	$\therefore$ Eqn of line is $y = -\frac{1}{8}x$	A1
3(i)	$y(x+d) = x+c$	
	$xy - x = -yd + c$	M1
	$\therefore c = 4$	B1
	Grad = $-\frac{4}{0.2} = -20$	M1
	$\therefore -d = -20$	
	$d = 20$	A1
(ii)	$\therefore xy - x = -20y + 4$	
	$a = -20(2.5) + 4 = -46$	B1
4	$\alpha^3 + \beta^3 = 0$	
	$(\alpha + \beta)[(\alpha + \beta)^2 - 3\alpha\beta] = 0$	
	$(\alpha + \beta)[(\alpha + \beta)^2 - 3\left(\frac{27}{64}\right)] = 0$	M1
	Since $\alpha \neq -\beta$ , $(\alpha + \beta)^2 = \frac{81}{64}$	
	$\alpha + \beta = \frac{9}{8}$ or $-\frac{9}{8}$ (NA)	A1
(i)	Quad eqn is $x^2 - \frac{9}{8}x + \frac{27}{64} = 0$	M1
	$64x^2 - 72x + 27 = 0$	B1
(ii)	Sum of roots = $\alpha - \beta + \beta - \alpha = 0$	
	Prod of roots = $(\alpha - \beta)(\beta - \alpha)$	
	$= \alpha\beta - \alpha^2 - \beta^2 + \alpha\beta$	
	$= 2\alpha\beta - (\alpha^2 + \beta^2)$	
	$= 2\alpha\beta - [(\alpha + \beta)^2 - 2\alpha\beta]$	M1
	$= 4\alpha\beta - (\alpha + \beta)^2$	
	$= 4\left(\frac{27}{64}\right) - \left(\frac{9}{8}\right)^2$	
	$= \frac{108}{64} - \frac{81}{64} = \frac{27}{64}$	
	$\therefore p = 0$ & $q = \frac{27}{64}$	B1, B1

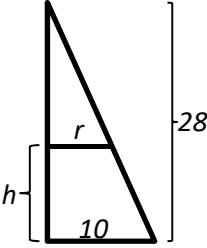
5(i)	To prove: $\sin^2 2x(\cot^2 x - \tan^2 x) = 4 \cos 2x$	
	Proof: LHS = $\sin^2 2x(\cot^2 x - \tan^2 x)$	
	$= \sin^2 2x \left( \frac{\cos^2 x}{\sin^2 x} - \frac{\sin^2 x}{\cos^2 x} \right)$	M1
	$= \sin^2 2x \left( \frac{\cos^4 x - \sin^4 x}{\sin^2 x \cos^2 x} \right)$	M1
	$= 4 \sin^2 x \cos^2 x \left( \frac{(\cos^2 x - \sin^2 x)(\cos^2 x + \sin^2 x)}{\sin^2 x \cos^2 x} \right)$	M1
	$= 4(\cos^2 x - \sin^2 x)$	M1
	$= 4 \cos 2x$	
	$= \text{RHS (proved)}$	
(ii)	$\sin^2 2x(\cot^2 x - \tan^2 x) = e$	
	$4 \cos 2x = e$	M1
	$\cos 2x = \frac{e}{4}$	
	$2x \approx 0.8236, 5.4596, 7.1068, 11.743$	
	$x \approx 0.412, 2.73, 3.55, 5.87$	A1, A1
6a(i)	 <p>Using Similar triangles,</p> $\frac{28-h}{28} = \frac{r}{10}$ $28-h = \frac{28}{10}r$ $h = 28 - \frac{14}{5}r \text{ (shown)}$	M1
(ii)	Vol of cylinder = $\pi r^2 h$	
	$V = \pi r^2 \left( 28 - \frac{14}{5}r \right)$	M1
	$V = 14\pi r^2 \left( 2 - \frac{1}{5}r \right)$ (shown)	
b(i)	$\frac{dV}{dr} = 56\pi r - \frac{14}{5}\pi(3r^2)$	
	$= 14\pi r \left( 4 - \frac{3}{5}r \right)$	M1
	At stat pt, $\frac{dV}{dr} = 0$	
	$14\pi r \left( 4 - \frac{3}{5}r \right) = 0$	M1

	$r = 0$ (NA), $4 - \frac{3}{5}r = 0 \Rightarrow r = 6\frac{2}{3}$	A1
	$\frac{d^2V}{dr^2} = 56\pi - \frac{84}{5}\pi r$	
	$= 56\pi - \frac{84}{5}\pi \left(6\frac{2}{3}\right)$	
	$= -175.93(2dp) < 0$	M1
	Since $\frac{d^2V}{dr^2} < 0$ , $\therefore r = 6\frac{2}{3}$ will make $V$ a maximum.	
	Max volume = $14\pi \left(\frac{20}{3}\right) \left(\frac{20}{3}\right) \left(2 - \frac{1}{5} \left[\frac{20}{3}\right]\right)$	
	$= \frac{11200}{27}\pi \text{ cm}^3$ or $1300 \text{ cm}^3$ (3sf)	B1
(ii)	<u>To show:</u> Vol of cylinder = $\frac{4}{9}$ (Vol of cone)	
	<u>Proof:</u> Vol of cone = $\frac{1}{3}\pi(10)^2(28) = \frac{2800}{3}\pi \text{ cm}^3$	M1
	$\frac{\text{Vol of cylinder}}{\text{Vol of cone}} = \frac{11200\pi}{27} \times \frac{3}{2800\pi} = \frac{4}{9}$	M1
	$\therefore$ Vol of cylinder = $\frac{4}{9}$ (Vol of cone) (shown)	
7a(i)	Mid-pt of $AB = \left(\frac{4+18}{2}, \frac{18+16}{2}\right) = (11, 17)$	M1
	Grad of $AB = \frac{18-16}{4-18} = -\frac{1}{7}$	
	Grad of perpendicular bisector = 7	M1
	Eqn of perpendicular bisector is $y - 17 = 7(x - 11)$	
	$y = 7x - 60$	A1
(ii)	Let the centre $P$ be $(m, m)$ .	
	$m = 7m - 60$	M1
	$m = 10$	
	$\therefore P = (10, 10)$	A1
(iii)	Eqn of circle is $(x - 10)^2 + (y - 10)^2 = 100$	B1
	Or $x^2 + y^2 - 20x - 20y + 100 = 0$	
(b)	Grad of $AP = \frac{18-10}{4-10}$	
	$= -\frac{4}{3}$	

	$\therefore$ Grad of tangent at $A = \frac{3}{4}$	
	Eqn of tangent at $A$ is $y - 18 = \frac{3}{4}(x - 4)$	
	$y = \frac{3}{4}x + 15$	
	$\therefore R = (-20, 0)$	B1
	Eqn of $AP$ is $y - 10 = -\frac{4}{3}(x - 10)$	
	$y = -\frac{4}{3}x + 23\frac{1}{3}$	
	$\therefore S = \left(17\frac{1}{2}, 0\right)$	B1
	$\therefore$ Area of $\triangle ARS = \frac{1}{2}\left(20 + 17\frac{1}{2}\right)(18)$	M1
	$= 337.5 \text{ units}^2$	A1
8	$x + y = 12$ -----(1)	B1
	$4xy = 140$ -----(2)	B1
	From eqn (1): $y = 12 - x$ substi into eqn (2)	
	$4x(12 - x) = 140$	M1
	$x^2 - 12x + 35 = 0$	
	$(x - 7)(x - 5) = 0$	
	$\therefore x = 7$ or $x = 5$	
	When $x = 7$ , $y = 5$	} A1
	When $x = 5$ , $y = 7$	
	$\therefore \sqrt{12 + \sqrt{140}} = (\sqrt{7} + \sqrt{5})$	A1
9(i)	$(2x - 1)(x^2 + 3) = 2x^3 - x^2 + 6x - 3$	
	$  \begin{array}{r}  \phantom{2x^3 - x^2 + 6x - 3} \overline{) 2x^3 - x^2 + 6x - 3} \\  \phantom{2x^3 - x^2 + 6x - 3} \underline{-(2x^4 - 5x^3 + 5x^2 - x - 10)} \\  \phantom{2x^3 - x^2 + 6x - 3} \phantom{-(2x^4 - 5x^3 + 5x^2 - x - 10)} \underline{-(-4x^3 + 2x^2 - 12x + 6)} \\  \phantom{2x^3 - x^2 + 6x - 3} \phantom{-(2x^4 - 5x^3 + 5x^2 - x - 10)} \phantom{-(-4x^3 + 2x^2 - 12x + 6)} \underline{-3x^2 + 14x - 16}  \end{array}  $	M1
	$\therefore$ Quotient = $x - 2$	A1
(ii)	$\frac{P(x)}{(2x - 1)(x^2 + 3)} = x - 2 + \frac{(-3x^2 + 14x - 16)}{(2x - 1)(x^2 + 3)}$	

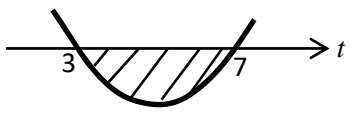
	$\frac{(-3x^2 + 14x - 16)}{(2x - 1)(x^2 + 3)} = \frac{A}{(2x - 1)} + \frac{(Bx + C)}{(x^2 + 3)}$ where $A, B$ and $C$ are constants	
	$-3x^2 + 14x - 16 = A(x^2 + 3) + (Bx + C)(2x - 1)$	M1
	When $x = \frac{1}{2}$ , $-3\left(\frac{1}{4}\right) + 14\left(\frac{1}{2}\right) - 16 = A\left(3\frac{1}{4}\right)$	
	$A = -3$	B1
	When $x = 0$ , $-16 = 3A - C$	
	$-16 = -9 - C$	
	$C = 7$	B1
	Comparing coeff of $x^2$ : $-3 = A + 2B$	
	$-3 = -3 + 2B$	
	$B = 0$	B1
	$\therefore \frac{P(x)}{(2x - 1)(x^2 + 3)} = x - 2 - \frac{3}{(2x - 1)} + \frac{7}{(x^2 + 3)}$	A1
10(i)	$\frac{dv}{dt} = 4t + (1 - 3k)$	
	When vel is a minimum, $\frac{dv}{dt} = 0$	
	$4(5) + (1 - 3k) = 0$	M1
	$3k = 21$	
	$k = 7 \text{ (shown)}$	A1
(ii)	When $k = 7$ , $v = 2t^2 - 20t + 55$	
	Discriminant = $(-20)^2 - 4(2)(55)$	
	$= 400 - 440$	
	$= -40$	
	$< 0$	M1
	$\Rightarrow$ there is no real values of $t$ such that $\text{vel} = 0$ , also $\text{vel} > 0$ hence particle will never return to $O$ with time.	A1
(iii)	$2t^2 - 20t + 55 < 13$	M1
	$2t^2 - 20t + 42 < 0$	
	$t^2 - 10t + 21 < 0$	
	$(t - 7)(t - 3) < 0$	
		$\therefore 3 < t < 7$
	$\text{Duration} = 7 - 3 = 4 \text{ s}$	A1

(iv)	$s = \int_2^3 (2t^2 - 20t + 55)dt$	M1
	$= \left[ \frac{2t^3}{3} - 10t^2 + 55t \right]_2^3$	
	$= [18 - 90 + 165] - \left[ \frac{16}{3} - 40 + 110 \right]$	
	$= 17\frac{2}{3} \text{ m} \quad \text{or } 17.7 \text{ m(3sf)}$	A1
11(i)	$\frac{3}{1-2x} = 2x+3$	M1
	$3 = (2x+3)(1-2x)$	
	$3 = 2x - 4x^2 + 3 - 6x$	
	$4x^2 + 4x = 0$	
	$4x(x+1) = 0$	
	$x = 0 \text{ or } x = -1$	
	For pt A: When $x = -1$ , $y = -2 + 3 = 1$	
	$\therefore A = (-1, 1)$	A1
(ii)	Area of shaded region $= \frac{1}{2}(1+3) - \int_{-1}^0 \frac{3}{1-2x} dx$	M1, M1
	$= 2 - \left[ \frac{3 \ln(1-2x)}{-2} \right]_{-1}^0$	M1
	$= 2 - \left[ 0 + \frac{3}{2} \ln 3 \right]$	
	$= 2 - 1.6479 \approx 0.352 \text{ units}^2$	A1
12(i)	<u>To prove:</u> $BD \parallel FE$	
	<u>Proof:</u> Let $\angle TAF$ be $\theta$ .	
	$\angle ABD = \angle TAF = \theta$ (alt seg thm)	M1
	$\angle AEF = \angle TAF = \theta$ (alt seg thm)	
	$\therefore \angle ABD = \angle AEF = \theta$	
	Using property of corresponding angles, $BD \parallel EF$ (shown)	A1
(ii)	<u>To prove:</u> $\angle FAC = \angle CAE$	
	<u>Proof:</u> Let $\angle BCE = \alpha$	
	$\angle CBD = \angle BCE = \alpha$ (alt $\angle$ s, $BD \parallel EF$ )	B1
	$\angle FAC = \angle CBD = \alpha$ ( $\angle$ s in same segment)	B1
	Also, $\angle CAE = \angle BCE = \alpha$ (alt seg thm)	B1
	$\therefore \angle FAC = \angle CAE = \alpha$ (shown)	
	<b>END</b>	

- 1 (i) A particle moves along the curve  $y = \ln(x^2 + 1)$  in such a way that the  $y$ -coordinate of the particle is decreasing at a constant rate of 0.2 units per second. Find the rate at which the  $x$ -coordinate of the particle is changing at the instant when  $x = -0.5$ . [3]
- (ii) Find the  $x$ -coordinates of the point on the curve where the gradient is **stationary**. [3]
- 2 (i) Solve the equation  $\log_3(2x+1) - \log_3(2x-3) = 1 + \log_3 \frac{2}{5}$ . [4]
- (ii) Solve the equation  $\ln y + 1 = 2 \log_y e$ , giving your answer(s) in terms of  $e$ . [5]
- 3 Given that  $y = e^x \sin x$ ,
- (i) show that  $2 \frac{dy}{dx} - \frac{d^2y}{dx^2} = 2y$ . [4]
- (ii) Hence, or otherwise, find the value of  $\int_0^{\frac{\pi}{3}} e^x \sin x \, dx$ . [4]
- 4 Given that the first three terms, in ascending powers of  $y$ , of the expansion of  $(a+y)^n$ , where  $a$  and  $n$  are positive real constants, are  $64 + 192y + 240y^2$ .
- (i) By considering the ratio of the coefficients of the first two terms, show that  $a = \frac{1}{3}n$ . [3]
- (ii) Find the value of  $a$  and of  $n$ . [4]
- 5 (a) Using the substitution  $u = 2^x$ , solve the equation  $4^{x+1} = 2^x + 3$ . [4]
- (b) The quantity,  $N$ , of a radioactive substance, at time  $t$  years, is given by  $N = N_0 e^{-kt}$ , where  $N_0$  and  $k$  are positive constants.
- (i) Sketch the graph of  $N$  against  $t$ , labelling any axes intercepts. [2]
- (ii) State the significance of  $N_0$ . [1]
- (iii) The quantity halves every 5 years. Calculate the value of  $k$ . [3]

**6 Solutions to this question by accurate drawing will not be accepted.**

The coordinates of the points  $P$  and  $Q$  are  $(-5, 2)$  and  $(7, 6)$  respectively. Find

(i) the equation of the line parallel to  $PQ$  and passing through the point  $(-2, 3)$ , [3]

(ii) the equation of the perpendicular bisector of  $PQ$ . [3]

A point  $R$  is such that the shortest distance of  $R$  from the line passing through  $P$  and  $Q$  is  $\sqrt{10}$  units.

(iii) Find the area of triangle  $PQR$ . [3]

7 The diagram shows a sketch of the curve  $y = f(x)$ . The  $x$ -coordinates of the maximum and minimum points are  $-\alpha$  and  $\alpha$ , where  $k > 0$ .

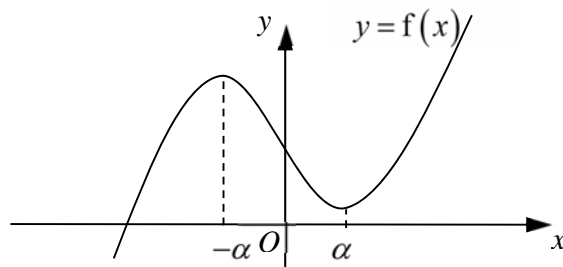

It is given that  $f'(x) = ax^2 + bx + c$ , where  $a$ ,  $b$  and  $c$  are real constants. For each of the following, state, with reasons, whether they are positive, negative or zero.

(i)  $b^2 - 4ac$ , [2]

(ii)  $\frac{b}{a}$ , [2]

(iii)  $\frac{c}{a}$ . [2]

- 8 The diagram shows the cross-section of a house with a rooftop  $BAC$ . The length of  $AB$  and  $AC$  are 10 m and 24 m respectively. The angle between  $AB$  and the horizontal through  $A$  is  $\theta$  degrees and  $\angle BAC = 90^\circ$ .

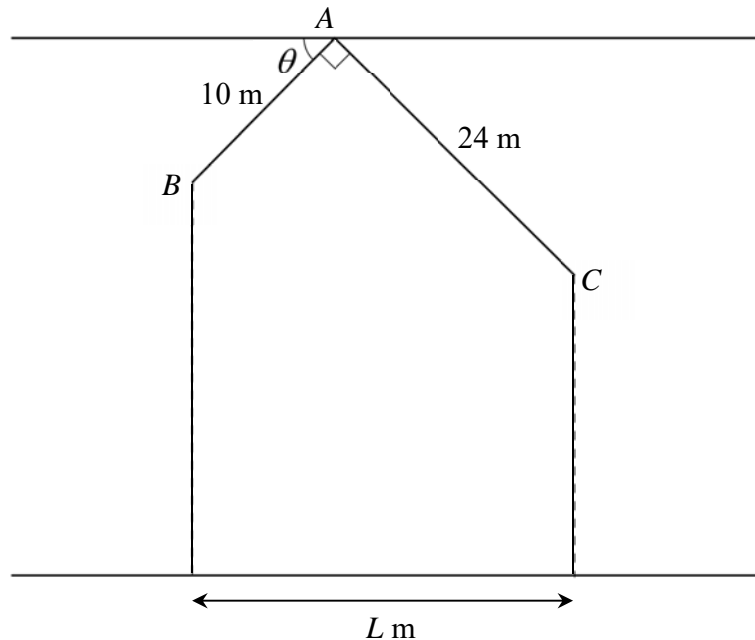

The base of the house is of length  $L$  m.

- (i) Show that  $L = 10\cos\theta + 24\sin\theta$ . [2]
- (ii) Express  $L$  in the form  $R\sin(\theta + \alpha)$ , where  $R > 0$  and  $\alpha$  is an acute angle. [4]
- (iii) Find the longest possible base of the house and the corresponding value of  $\theta$ . [3]
- 9 (a) The equation of a curve is  $y = \frac{2x}{1+x}$ .
- (i) Find the equation of the tangent to the curve at point  $P(1,1)$ . [4]
- (ii) The tangent cuts the axes at  $Q$  and  $R$  respectively. Find the area of triangle  $OPQ$ . [2]
- (b) A curve has equation  $y = f(x)$ , where  $f(x) = \frac{1}{3}x^3 - 2x^2 + 13x + 5$ .
- Determine, with explanation, whether  $f$  is an increasing or decreasing function. [4]

- 10 (a) (i)** Solve the equation  $|x^2 - 3x + 2| + x = 1$ . [3]
- (ii)** What can be deduced about the number of points of intersections of the graphs of  $y = |x^2 - 3x + 2|$  and  $y = -x + 1$ ? [1]
- (iii)** Hence, on a single diagram, sketch the graphs of  $y = |x^2 - 3x + 2|$  and  $y = -x + 1$ , indicating the coordinates of any axial intercepts and turning point. [4]
- (b)** The diagram shows part of the graph of  $y = |k - x|$ , where  $k$  is a constant.

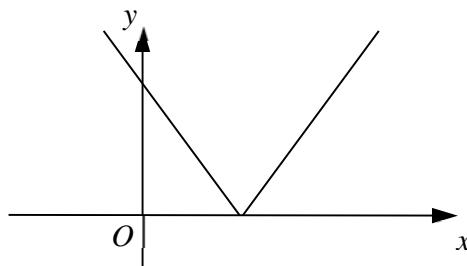

A line  $y = mx + c$  is drawn to determine the number of solutions to the equation  $|k - x| = mx + c$ .

- (i)** If  $m = 1$ , state the range of values of  $c$ , in terms of  $k$ , such that the equation has one solution. [1]
- (ii)** If  $c = 0$ , state the range of values of  $m$  such that the equation has no solutions. [2]
- 11 (a)** State the principal range of  $\sin^{-1} x$ , leaving your answers in terms of  $\pi$ . [1]
- (b) (i)** Prove that  $\frac{1 + \tan x}{1 - \tan x} = \sec 2x + \tan 2x$ . [5]
- (ii)** Hence find the reflex angle  $x$  such that  $3 \sec 2x + 3 \tan 2x = 1$ . [3]
- (c)** A buoy floats and its height above the seabed,  $h$  m, is given by  $h = a \cos bt + c$ , where  $t$  is time measured in hours from 0000 hours and  $a$ ,  $b$  and  $c$  are constants. The least height of the buoy above seabed is 180 metres and is recorded at 0000 hours. The greatest height of the buoy above seabed is 196 metres and is first recorded at 0600 hours.
- (i)** Find the values of  $a$ ,  $b$  and  $c$ . [3]
- (ii)** Using values found in **(i)**, sketch the graph of  $h = a \cos bt + c$  for  $0 \leq t \leq 24$ . [2]
- (ii)** The buoy floats above the top of a huge rock first at 0500 hours. State the number of hours in each day that the buoy is above the rock. [1]

**END OF PAPER**

**Question 1**

(i)	0.25 units/s
(ii)	$x = \pm 1$

**Question 2**

(i)	$x = \frac{23}{2}$
(ii)	$y = e^{-2}$ or $y = e$

**Question 3**

(ii)	1.02(3s.f.)
------	-------------

**Question 4**

(ii)	$n = 6, a = 2$
------	----------------

**Question 5**

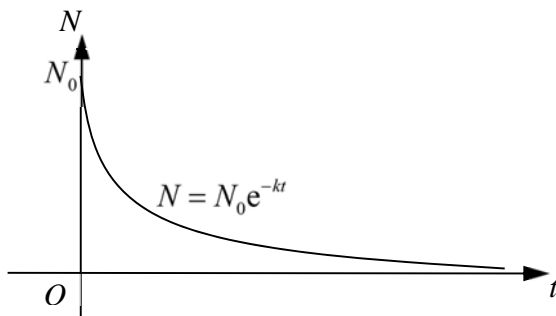
(a)	$x = 0$
(a)(i)	
(ii)	It represents the initial amount of radioactive substance.
(iii)	0.139

**Question 6**

(i)	$y = \frac{1}{3}x + 3\frac{2}{3}$
(ii)	$y = -3x + 7$
(iii)	20 units <sup>2</sup>

**Question 7**

(i)	$b^2 - 4ac > 0$ .
(ii)	$\frac{b}{a} > 0$
(iii)	$\frac{c}{a} < 0$

**Question 8**

(ii)	$L = 26 \sin(\theta + 22.6^\circ)$
(iii)	Longest possible base is 26 m.

	$\theta = 67.4^\circ (1 \text{ d.p.})$
--	--

**Question 9**

(a)(i)	$y = \frac{1}{2}x + \frac{1}{2}$
(ii)	$\frac{1}{4} \text{ units}^2$

**Question 10**

(a)(i)	$x = 1$
(ii)	The line $y = -x + 1$ is tangential to $y =  x^2 - 3x + 2 $ .
(ii)	
(b)(i)	$c > -k$
(ii)	$-1 \leq m < 0$

**Question 11**

(a)	$-\frac{\pi}{2} \leq \sin^{-1} x \leq \frac{\pi}{2}$
(b)(ii)	$x = 333.3^\circ (1 \text{ d.p.})$
(c)(i)	$a = -8, b = \frac{\pi}{6}, c = 188$
(iii)	4 hours

- 1 (i) A particle moves along the curve  $y = \ln(x^2 + 1)$  in such a way that the  $y$ -coordinate of the particle is decreasing at a constant rate of 0.2 units per second. Find the rate at which the  $x$ -coordinate of the particle is changing at the instant when  $x = -0.5$ . [3]
- (ii) Find the  $x$ -coordinates of the point on the curve where the gradient is **stationary**. [3]

(i)	$\frac{dy}{dx} = \frac{2x}{x^2 + 1}$ $\frac{dy}{dt} = \frac{dy}{dx} \times \frac{dx}{dt}$ $-0.2 = \frac{2(-0.5)}{(-0.5)^2 + 1} \times \frac{dx}{dt}$ $\Rightarrow \frac{dx}{dt} = 0.25 \text{ units/s}$	<p><b>B1</b></p> <p><b>M1</b></p> <p><b>A1</b></p>
(ii)	$\frac{d^2y}{dx^2} = \frac{(x^2 + 1)(2) - 2x(2x)}{(x^2 + 1)^2}$ $= \frac{2 - 2x^2}{(x^2 + 1)^2}$ $\frac{d^2y}{dx^2} = 0$ $2 - 2x^2 = 0$ $x = \pm 1$	<p><math>\sqrt{\text{M1}}</math></p> <p><b>M1</b></p> <p><b>A1</b></p>

2 (i) Solve the equation  $\log_3(2x+1) - \log_3(2x-3) = 1 + \log_3 \frac{2}{5}$ . [4]

(ii) Solve the equation  $\ln y + 1 = 2 \log_y e$ , giving your answer(s) in terms of  $e$ . [5]

(i)	$\log_3(2x+1) - \log_3(2x-3) = 1 + \log_3 \frac{2}{5}$ $\log_3 \frac{2x+1}{2x-3} = \log_3 \left( 3 \times \frac{2}{5} \right)$ $\frac{2x+1}{2x-3} = \frac{6}{5}$ $10x+5 = 12x-18$ $2x = 23$ $x = \frac{23}{2}$	<p><b>B1, B1</b></p> <p><b>M1</b> – remove log</p> <p><b>A1</b></p>
(ii)	$\ln y + 1 = 2 \log_y e$ $\ln y + 1 = \frac{2}{\ln y}$ $(\ln y)^2 + \ln y - 2 = 0$ $(\ln y + 2)(\ln y - 1) = 0$ $\ln y = -2 \text{ or } 1$ $y = e^{-2} \text{ or } y = e$	<p><b>B1</b> – change base</p> <p><b>B1</b></p> <p><b>M1</b> – attempt to solve</p> <p><b>A2</b></p>

3 Given that  $y = e^x \sin x$ ,

(i) show that  $2 \frac{dy}{dx} - \frac{d^2y}{dx^2} = 2y$ . [4]

(ii) Hence, or otherwise, find the value of  $\int_0^{\frac{\pi}{3}} e^x \sin x \, dx$ . [4]

(i)	$y = e^x \sin x$ $\frac{dy}{dx} = e^x \sin x + e^x \cos x$ $\frac{d^2y}{dx^2} = e^x \sin x + e^x \cos x - e^x \sin x + e^x \cos x$ $= 2e^x \cos x$ $-\frac{d^2y}{dx^2} + 2\frac{dy}{dx} = -2e^x \cos x + 2(e^x \sin x + e^x \cos x)$ $= 2e^x \sin x$ $= 2y$ $2\frac{dy}{dx} - \frac{d^2y}{dx^2} = 2y$	<p><b>M1</b> – product rule  <b>B1</b>  <b>M1</b> – product rule    <b>M1</b>    <b>a.g.</b></p>
(ii)	$-\frac{d^2y}{dx^2} + 2\frac{dy}{dx} = 2y$ $\therefore -\frac{dy}{dx} + 2y = 2 \int e^x \sin x \, dx$ $\Rightarrow -e^x \sin x - e^x \cos x + 2e^x \sin x = 2 \int e^x \sin x \, dx$ $\therefore \int e^x \sin x \, dx = \frac{1}{2}(e^x \sin x - e^x \cos x) + c$ $\int_0^{\frac{\pi}{3}} e^x \sin x \, dx = \left[ \frac{1}{2}(e^x \sin x - e^x \cos x) \right]_0^{\frac{\pi}{3}}$ $= 1.02 \text{ (3s.f.)}$	<p><b>M1</b> – integration    <b>B1</b> – making integral the subject    <b>M1</b> – substitution of limits  <b>A1</b></p>

4 Given that the first three terms, in ascending powers of  $y$ , of the expansion of  $(a + y)^n$ , where  $a$  and  $n$  are positive real constants, are  $64 + 192y + 240y^2$ .

(i) By considering the ratio of the coefficients of the first two terms, show that  $a = \frac{1}{3}n$ . [3]

(ii) Find the value of  $a$  and of  $n$ . [4]

(i)	$(a + y)^n = a^n + na^{n-1}y + \frac{n(n-1)}{2}a^{n-2}y^2 + \dots$ <p>By comparing coefficients,</p> $a^n = 64 \quad \text{---(1)}$ $na^{n-1} = 192 \quad \text{---(2)}$ $\frac{n(n-1)}{2}a^{n-2} = 240 \quad \text{---(3)}$ $\frac{(1)}{(2)} : \frac{a}{n} = \frac{64}{192} = \frac{1}{3} \Rightarrow a = \frac{1}{3}n \text{---(4)}$	<p><b>B1</b> – award for first two terms</p> <p><b>M1, A1</b></p>
(ii)	$\frac{(2)}{(3)} : \frac{2a}{n-1} = \frac{192}{240} = \frac{4}{5} \Rightarrow a = \frac{2}{5}(n-1) \text{---(5)}$ <p>(4) = (5):</p> $\frac{1}{3}n = \frac{2}{5}(n-1)$ $5n = 6n - 6$ $n = 6$ $\Rightarrow a = 2$	<p><math>\sqrt{\text{M1}}</math></p> <p><math>\sqrt{\text{M1}}</math> – simultaneous eqn</p> <p><b>A1</b></p> <p><b>A1</b></p>

- 5 (a) Using the substitution  $u = 2^x$ , solve the equation  $4^{x+1} = 2^x + 3$ . [4]
- (b) The quantity,  $N$ , of a radioactive substance, at time  $t$  years, is given by  $N = N_0 e^{-kt}$ , where  $N_0$  and  $k$  are positive constants.
- (i) Sketch the graph of  $N$  against  $t$ , labelling any axes intercepts. [2]
- (ii) State the significance of  $N_0$ . [1]
- (iii) The quantity halves every 5 years. Calculate the value of  $k$ . [3]

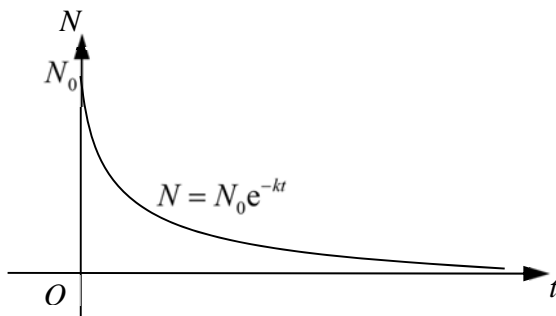
<b>(a)</b>	$4u^2 = u + 3$ $4u^2 - u - 3 = 0$ $(4u + 3)(u - 1) = 0$ $u = 1 \text{ or } -\frac{3}{4}$ $x = 0 \text{ or } 2^x = -\frac{3}{4} \text{ (no solutions)}$	<b>B1</b>          <b>M1</b>  <b>A1, A1</b>
<b>(a)(i)</b>		<b>B1</b> – shape <b>B1</b> – $t > 0$ and label $N_0$
<b>(ii)</b>	It represents the initial amount of radioactive substance.	<b>B1</b>
<b>(iii)</b>	$\frac{1}{2} N_0 = N_0 e^{-k(5)}$ $\frac{1}{2} = e^{-5k}$ $-5k = \ln \frac{1}{2} = -\ln 2$ $t = \frac{\ln 2}{5} \approx 0.139$	<b>M1</b>       <b>M1</b>  <b>A1</b>

**6 Solutions to this question by accurate drawing will not be accepted.**

The coordinates of the points  $P$  and  $Q$  are  $(-5, 2)$  and  $(7, 6)$  respectively. Find

(i) the equation of the line parallel to  $PQ$  and passing through the point  $(-2, 3)$ . [3]

(ii) the equation of the perpendicular bisector of  $PQ$ . [3]

A point  $R$  is such that the shortest distance of  $R$  from the line passing through  $P$  and  $Q$  is  $\sqrt{10}$  units.

(iii) Find the area of triangle  $OQR$ . [3]

(i)	$m_{PQ} = \frac{6-2}{7-(-5)} = \frac{1}{3}$ $y-3 = \frac{1}{3}[x-(-2)]$ $y = \frac{1}{3}x + 3\frac{2}{3}$	<p><b>B1</b></p> <p><b>M1</b></p> <p><b>A1</b></p>
(ii)	<p>Midpoint of <math>PQ = \left(\frac{-5+7}{2}, \frac{2+6}{2}\right) = (1, 4)</math></p> <p>Gradient of perpendicular bisector = <math>-3</math></p> $y-4 = -3(x-1)$ $y = -3x + 7$	<p><b>B1</b></p> <p><math>\sqrt{\text{M1}}</math></p> <p><b>A1</b></p>
(iii)	$PQ = \sqrt{(7-(-5))^2 + (6-2)^2} = 4\sqrt{10} \text{ units}$ $\text{Area} = \frac{1}{2}(4\sqrt{10})\sqrt{10}$ $= 20 \text{ units}^2$	<p><b>M1</b></p> <p><math>\sqrt{\text{M1}}</math></p> <p><b>A1</b></p>

- 7 The diagram shows a sketch of the curve  $y = f(x)$ . The  $x$ -coordinates of the minimum and maximum points are  $\alpha$  and  $-\alpha$ , where  $\alpha > 0$ .

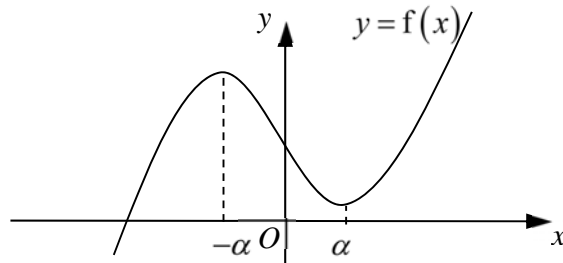

It is given that  $f'(x) = ax^2 + bx + c$ , where  $a$ ,  $b$  and  $c$  are real constants. For each of the following, state, with reasons, whether they are positive, negative or zero.

- (i)  $b^2 - 4ac$ , [2]
- (ii)  $\frac{b}{a}$ , [2]
- (iii)  $\frac{c}{a}$ . [2]

(i)	Since there are two stationary points, $f'(x) = 0$ has two real roots, therefore $b^2 - 4ac > 0$ .	M1 A1
(ii)	Since $ \alpha  >  \beta $ and $\alpha < 0$ , $\alpha + \beta < 0$ , $\therefore \frac{b}{a} = -(\alpha + \beta) > 0$	M1 A1
(iii)	Since $\alpha < 0$ and $\beta > 0$ , $\alpha\beta < 0$ , $\therefore \frac{c}{a} = \alpha\beta < 0$	M1 A1

- 8 The diagram shows the cross-section of a house with a rooftop  $BAC$ . The length of  $AB$  and  $AC$  are 10 m and 24 m respectively. The angle between  $AB$  and the horizontal through  $A$  is  $\theta$  degrees and  $\angle BAC = 90^\circ$ .

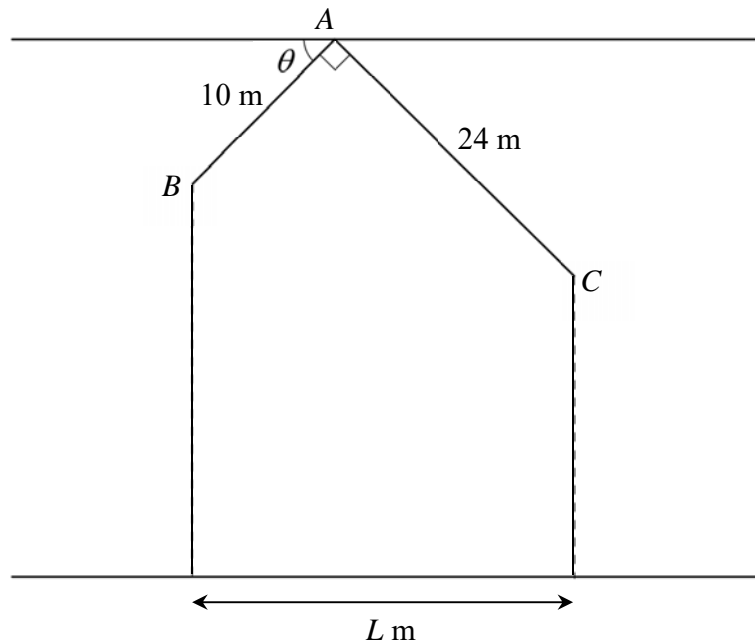

The base of the house is of length  $L$  m.

- (i) Show that  $L = 10 \cos \theta + 24 \sin \theta$ . [2]
- (ii) Express  $L$  in the form  $R \sin(\theta + \alpha)$ , where  $R > 0$  and  $\alpha$  is an acute angle. [4]
- (iii) Find the longest possible base of the house and the corresponding value of  $\theta$ . [3]

(i)	Let the point vertically above $B$ and $C$ be $M$ and $N$ respectively. $\angle ACN = 90^\circ$ $AM = 10 \cos \theta$ and $AN = 24 \sin \theta$ $L = MN = 10 \cos \theta + 24 \sin \theta$	<b>B1, B1</b>
(ii)	$R = \sqrt{10^2 + 24^2}$ $= 26$ $\alpha = \tan^{-1}\left(\frac{10}{24}\right)$ $= 22.620^\circ (3 \text{ d.p.})$ $L = 26 \sin(\theta + 22.6^\circ)$	<b>M1</b> <b>A1</b> <b>M1</b> <b>A1</b>
(iii)	Longest possible base is 26 m. $\theta + 22.620^\circ = 90^\circ$ $\theta = 67.4^\circ (1 \text{ d.p.})$	<b>B1</b> <b><math>\sqrt{\text{M1}}</math></b> <b>A1</b>

9 (a) The equation of a curve is  $y = \frac{2x}{1+x}$ .

(i) Find the equation of the tangent to the curve at point  $P(1,1)$ . [4]

(ii) The tangent cuts the axes at  $Q$  and  $R$  respectively. Find the area of triangle  $PQR$ . [2]

(b) A curve has equation  $y = f(x)$ , where  $f(x) = \frac{1}{3}x^3 - 2x^2 + 13x + 5$ .

Determine, with explanation, whether  $f$  is an increasing or decreasing function. [4]

<p>(a) (i)</p>	$\frac{dy}{dx} = \frac{(1+x)(2) - (2x)(1)}{(1+x)^2}$ $= \frac{2}{(1+x)^2}$ $\left. \frac{dy}{dx} \right _{x=1} = \frac{1}{2}$ <p>Equation of Tangent: <math>y - 1 = \frac{1}{2}(x - 1) \Rightarrow y = \frac{1}{2}x + \frac{1}{2}</math></p>	<p><b>M1</b></p> <p><b>B1</b></p> <p><b>M1</b> – substitution of point <b>A1</b></p>
<p>(ii)</p>	<p><math>Q(-1,0)</math> and <math>R\left(0, \frac{1}{2}\right)</math></p> <p>Area of Triangle = <math>\frac{1}{2}(1)\left(\frac{1}{2}\right) = \frac{1}{4}</math> units<sup>2</sup></p>	<p><math>\sqrt{\text{B1}}</math></p> <p><math>\sqrt{\text{B1}}</math></p>
<p>(b)</p>	<p><math>f'(x) = x^2 - 4x + 13</math></p> <p><math>= (x - 2)^2 - 2^2 + 13</math></p> <p><math>= (x - 2)^2 + 9</math></p> <p><math>(x - 2)^2 \geq 0 \Rightarrow (x - 2)^2 + 9 &gt; 0</math></p> <p><math>\therefore f'(x) &gt; 0</math>, <math>f</math> is an increasing function.</p>	<p><b>B1</b></p> <p><b>M1</b> - complete the square</p> <p><b>M1</b></p> <p><b>A1</b></p>

**10 (a) (i)** Solve the equation  $|x^2 - 3x + 2| + x = 1$ . [3]

**(ii)** What can be deduced about the number of points of intersections of the graphs of  $y = |x^2 - 3x + 2|$  and  $y = -x + 1$ ? [1]

**(iii)** Hence, on a single diagram, sketch the graphs of  $y = |x^2 - 3x + 2|$  and  $y = -x + 1$ , indicating any axial intercepts. [4]

**(b)** The diagram shows part of the graph of  $y = |k - x|$ , where  $k$  is a constant.

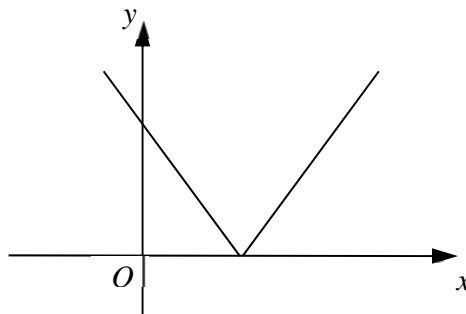

A line  $y = mx + c$  is drawn to determine the number of solutions to the equation  $|k - x| = mx + c$ .

**(i)** If  $m = 1$ , state the range of values of  $c$ , in terms of  $k$ , such that the equation has one solution. [1]

**(ii)** If  $c = 0$ , state the range of values of  $m$  such that the equation has no solutions. [2]

<b>(a)</b> <b>(i)</b>	$x^2 - 3x + 2 = -x + 1$ or $x^2 - 3x + 2 = -(-x + 1)$ $x^2 - 2x + 1 = 0$ $x^2 - 4x + 3 = 0$ $(x - 1)^2 = 0$ $(x - 3)(x - 1) = 0$ $x = 1$ $x = 1$ or $x = 3$ (rejected)	<b>M1</b>    <b>A1, A1</b>
<b>(ii)</b>	The line $y = -x + 1$ is tangential to $y =  x^2 - 3x + 2 $ .	<b>B1</b>

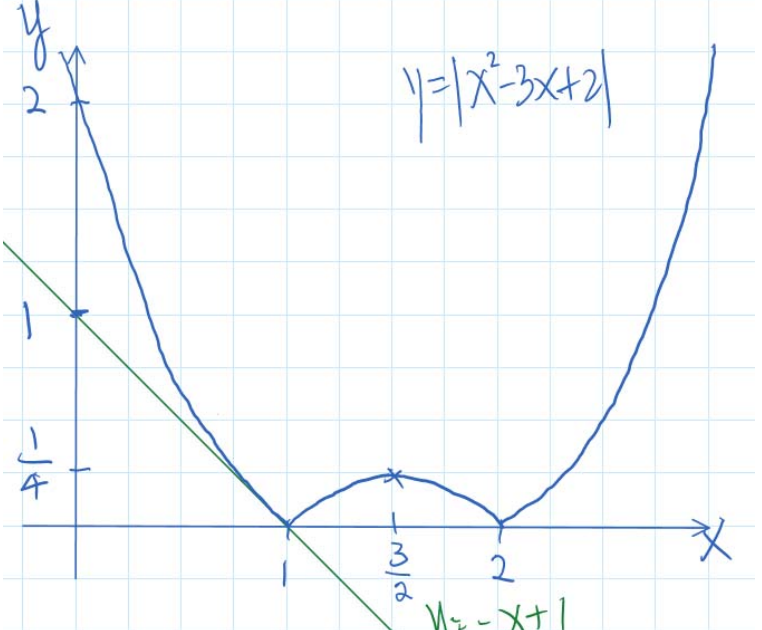
<b>(ii)</b>		<b>B1</b> - modulus graph <b>B1</b> - axial intercepts & turning point <b>B1</b> - line with intercepts <b>B1</b> - line tangent to modulus
<b>(b)(i)</b>	$c > -k$	<b>B1</b>
<b>(ii)</b>	$-1 \leq m < 0$	<b>A1, A1</b>

11 (a) State the principal range of  $\sin^{-1} x$ , leaving your answers in terms of  $\pi$ . [1]

(b) (i) Prove that  $\frac{1 + \tan x}{1 - \tan x} = \sec 2x + \tan 2x$ . [5]

(ii) Hence find the reflex angle  $x$  such that  $\sec 2x + \tan 2x = \frac{1}{3}$ . [3]

(c) A buoy floats and its height above the seabed,  $h$  m, is given by  $h = a \cos bt + c$ , where  $t$  is time measured in hours from 0000 hours and  $a$ ,  $b$  and  $c$  are constants. The least height of the buoy above seabed is 180 metres and is recorded at 0000 hours. The greatest height of the buoy above seabed is 196 metres and is first recorded at 0600 hours.

(i) Find the values of  $a$ ,  $b$  and  $c$ . [3]

(ii) Using values found in (i), sketch the graph of  $h = a \cos bt + c$  for  $0 \leq t \leq 24$ . [2]

(ii) The buoy floats above the top of a huge rock first at 0500 hours. State the number of hours in each day that the buoy is above the rock. [1]

(a)	$-\frac{\pi}{2} \leq \sin^{-1} x \leq \frac{\pi}{2}$	<b>B1</b>
(b) (i)	$\frac{1 + \tan x}{1 - \tan x} = \frac{1 + \frac{\sin x}{\cos x}}{1 - \frac{\sin x}{\cos x}}$ $= \frac{\cos x + \sin x}{\cos x - \sin x}$ $= \frac{(\cos x + \sin x)^2}{\cos^2 x - \sin^2 x}$ $= \frac{1 + 2 \sin x \cos x}{\cos 2x}$ $= \frac{1 + \sin 2x}{\cos 2x}$ $= \sec 2x + \tan 2x$	<b>M1</b>  <b>M1</b>  <b>M1 – double angle</b> <b>M1 – double angle</b> <b>A1</b>
(ii)	$\frac{1 + \tan x}{1 - \tan x} = \frac{1}{3}$ $3 + 3 \tan x = 1 - \tan x$ $4 \tan x = -2$ $\tan x = -\frac{1}{2}$ $\alpha = 26.565^\circ (3 \text{ d.p.})$ $x = 333.3^\circ (1 \text{ d.p.})$	<b>M1</b>     <b>B1</b> <b>A1</b>

<p><b>(c)</b> <b>(i)</b></p>	$\frac{196-180}{2} = 8 \Rightarrow a = -8$ $c = \frac{196+180}{2} = 188$ $b = \frac{2\pi}{12} = \frac{\pi}{6}$	<p><b>B1</b></p> <p><b>B1</b></p> <p><b>B1</b></p>
<p><b>(ii)</b></p>		<p><b>B1</b> – shape</p> <p><b>B1</b> – points</p>
<p><b>(iii)</b></p>	<p>4 hours</p>	<p><b>B1</b></p>