

Visit

FREETESTPAPER.com

for more papers



Website: [freetestpaper.com](http://www.freetestpaper.com)



[Facebook.com/freetestpaper](https://www.facebook.com/freetestpaper)



[Twitter.com/freetestpaper](https://www.twitter.com/freetestpaper)

SECONDARY 4
2018 Preliminary Examinations

ADDITIONAL MATHEMATICS
Paper 1

4047/1

10 September 2018 (Monday)

2 hours

CANDIDATE
NAME

Solutions

CLASS

--

INDEX
NUMBER

--	--

READ THESE INSTRUCTIONS FIRST

Do not turn over the page until you are told to do so.

Write your name, class and index number in the spaces provided above.

Write in dark blue or black pen on both sides of the paper. You may use a pencil for any diagrams or graphs.

Do not use staples, paper clips, highlighters, glue or correction fluid/tape.

INFORMATION FOR CANDIDATES

Answer **all** the questions.

Write your answers on the separate writing paper provided.

Give non-exact numerical answers correct to 3 significant figures, or 1 decimal place in the case of angles in degrees, unless a different level of accuracy is specified in the question.

The use of a scientific calculator is expected, where appropriate.

You are reminded of the need for clear presentation in your answers.

At the end of the examination, fasten all your answer scripts securely together.

The number of marks is given in brackets [] at the end of each question or part question.

The total number of marks for this paper is **80**.

For Examiner's Use		
Q1	3	
Q2	6	
Q3	5	
Q4	5	
Q5	5	
Q6	6	
Q7	6	
Q8	8	
Q9	9	
Q10	9	
Q11	9	
Q12	9	
Total	/80	

Mathematical Formulae

1. ALGEBRA

Quadratic Equation

For the equation $ax^2 + bx + c = 0$,

$$x = \frac{-b \pm \sqrt{b^2 - 4ac}}{2a}$$

Binomial Expansion

$$(a + b)^n = a^n + \binom{n}{1} a^{n-1} b + \binom{n}{2} a^{n-2} b^2 + \dots + \binom{n}{r} a^{n-r} b^r + \dots + b^n$$

where n is a positive integer and $\binom{n}{r} = \frac{n!}{r!(n-r)!} = \frac{n(n-1)\dots(n-r+1)}{r!}$

2. TRIGONOMETRY

Identities

$$\sin^2 A + \cos^2 A = 1$$

$$\sec^2 A = 1 + \tan^2 A$$

$$\operatorname{cosec}^2 A = 1 + \cot^2 A$$

$$\sin(A \pm B) = \sin A \cos B \pm \cos A \sin B$$

$$\cos(A \pm B) = \cos A \cos B \mp \sin A \sin B$$

$$\tan(A \pm B) = \frac{\tan A \pm \tan B}{1 \mp \tan A \tan B}$$

$$\sin 2A = 2 \sin A \cos A$$

$$\cos 2A = \cos^2 A - \sin^2 A = 2 \cos^2 A - 1 = 1 - 2 \sin^2 A$$

$$\tan 2A = \frac{2 \tan A}{1 - \tan^2 A}$$

Formulae for ΔABC

$$\frac{a}{\sin A} = \frac{b}{\sin B} = \frac{c}{\sin C}$$

$$a^2 = b^2 + c^2 - 2bc \cos A$$

$$\Delta = \frac{1}{2} ab \sin C$$

1. Given that $a = \sqrt{2} - \sqrt{3}$, find the value of a^2 , leaving your answer in exact form. Hence, or otherwise, and without the use of a calculator, find the exact value of $2a^4 - 16a^2 + 5$. [3]

2. A curve, for which $\frac{dy}{dx} = kx^2 - 8$, has a gradient of -4 at $x = 2$.
 (i) State the value of k . [1]

With this value of k , find

- (ii) the equation of the normal at point $P(3, -2)$, [2]
 (iii) the equation of the curve y . [3]
3. (i) Sketch the graph of $y^2 = 9x$. [2]

- (ii) You were going through your old notes and happen to come across the following graph sketched on a piece of paper. It brought back some memories of your time in SST because you had to draw that graph in a Mathematics quiz. However, the equation of the function is missing from the graph. You decided to complete the equation before putting the graph back into the pile.

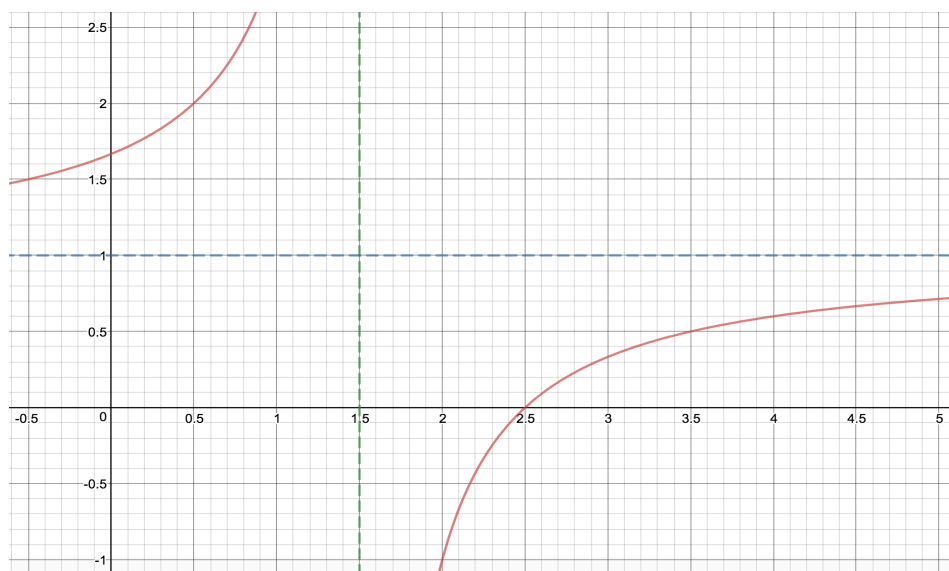

- Given that the y -intercept of the graph is $\frac{5}{3}$ and that the equation is of the form $y = \frac{k}{(x-h)} + c$, where h, k, c are constants that need to be determined, find the value of h , of k and of c . [3]

4. Express $\frac{2x^2 + x + 1}{(x+1)(x-2)}$ in partial fractions. [5]

5. Answer the whole of this question on a piece of graph paper.

Variables x and y are known to be related by an equation of the form $y = a\sqrt{x} + \frac{b}{\sqrt{x}}$, where a and b are constants. The table shows experimental values of the two variables.

x	1.0	1.5	2.0	2.5	3.0	3.5
y	2.4	3.9	5.1	6.4	7.4	8.3

(i) Plot $y\sqrt{x}$ against x and draw a straight-line graph. [3]

(ii) Use the graph to estimate the values of a and of b . [2]

6. Given that the roots of the quadratic equation $2x^2 + x + 6 = 0$ are α and β .

(i) Find the quadratic equation whose roots are $\left(\alpha + \frac{1}{2\beta}\right)$ and $\left(\beta + \frac{1}{2\alpha}\right)$. [4]

(ii) Explain why the value for $\alpha - \beta$ is undefined. [2]

7. (i) Prove the following trigonometric identity:

$$\left(\frac{1 - \cos\theta}{1 + \cos\theta}\right) \equiv (\operatorname{cosec}\theta - \cot\theta)^2. \quad [3]$$

(ii) Hence, for $-\pi \leq \theta \leq \pi$, solve the equation $(\operatorname{cosec}\theta - \cot\theta)^2 = 5$. [3]

8.

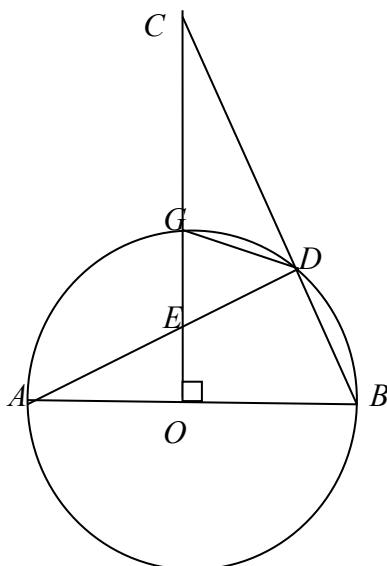

AB is a diameter of the circle with centre O . C is a point on OG produced and CB intersects the circle at D . OG is perpendicular to AB and OG intersects the chord AD at E ,

- (i) Prove that $AE \times ED = OE \times EC$. [4]
- (ii) Explain why C is at an equal distance from A and B . [2]
- (iii) Explain why a circle with BC as a diameter passes through O . [2]

9. The straight line $3x - y + 5 = 0$ and the curve $x^2 + y^2 - 2x - 6y + 5 = 0$ intersect at two points, A and B .

- (i) Find the coordinates of A and of B . [3]
- (ii) Find the equation of the perpendicular bisector of AB . [3]
- (iii) Find the coordinates of the centre of the circle $x^2 + y^2 - 2x - 6y + 5 = 0$ and determine whether the point $(1, 1)$ lies within, outside or on the circumference of the circle. [3]

10. A piece of wire of length 680m is bent to form an enclosure consisting of a trapezium $ABCD$ and a quadrant ADE with $AB = y$ m, $DE = x$ m and $\hat{BCD} = 45^\circ$.

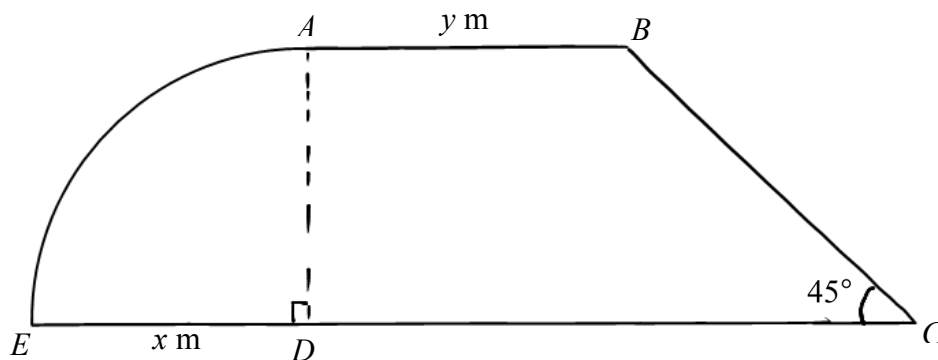

- (i) Show that the area A m² of the enclosure is given by
- $$A = 340x - \frac{\sqrt{2} + 1}{2} x^2. \quad [4]$$
- (ii) Find the value of x , correct to 2 decimal places, for which there is a stationary value for A and determine whether it is a maximum or a minimum. [5]
11. A particle starts from a point O and moves in a straight line so that its velocity, v m/s, is given by $v = (3t + 5)(t - 5)$ where t is the time in seconds after leaving O .
- Find,
- (i) the time(s) when the particle is at rest, [2]
- (ii) the time when the particle passes through O again, [3]
- (iii) the distance travelled during the third second, [2]
- (iv) the time interval during which the velocity is decreasing. [2]

12.

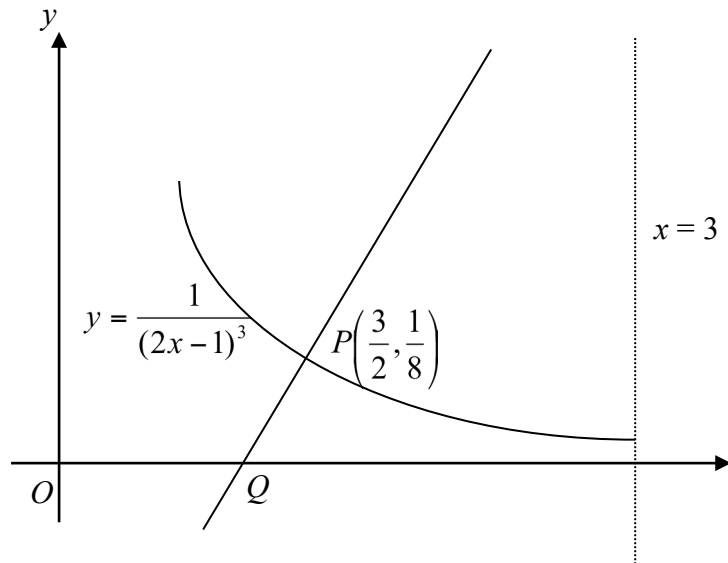

In the diagram above the line PQ is normal to the curve $y = \frac{1}{(2x-1)^3}$ at the point $P\left(\frac{3}{2}, \frac{1}{8}\right)$.

(i) Find the length of OQ . [4]

(ii) Find the area bounded by the line PQ , the curve $y = \frac{1}{(2x-1)^3}$ and the line $x = 3$. [5]

END OF PAPER

$$\textcircled{1} \quad a = \sqrt{2} - \sqrt{3}$$

$$a^2 = (\sqrt{2} - \sqrt{3})^2$$

$$= 2 - 2\sqrt{2}\sqrt{3} + 3$$

$$= 5 - 2\sqrt{6}$$

$$\therefore 2a^4 - 16a^2 + 5 = 2(a^2)^2 - 16(a^2) + 5$$

$$= 2[5 - 2\sqrt{6}]^2 - 16(5 - 2\sqrt{6}) + 5$$

$$= 2[25 - 2(5)(2\sqrt{6}) + 24] - 80 + 32\sqrt{6} + 5$$

$$= 2[49 - 20\sqrt{6}] - 75 + 32\sqrt{6}$$

$$= 23 - 8\sqrt{6} \#$$

$$(2) \frac{dy}{dx} = kx^2 - 8$$

$$(i) \text{ (a) } x=2, \frac{dy}{dx} = -4$$

$$-4 = k(2)^2 - 8$$

$$k = 1 \#$$

$$(ii) \frac{dy}{dx} = x^2 - 8$$

$$\text{(a) } x=3, \frac{dy}{dx} = 3^2 - 8$$

$$= 1$$

\therefore the equation of the normal

$$y - (-2) = \frac{-1}{1}(x - 3)$$

$$y = -x + 1 \#$$

$$(iii) y = \int x^2 - 8 \, dx$$

$$= \frac{1}{3}x^3 - 8x + C$$

$$\text{(a) } P(3, -2)$$

$$-2 = \frac{1}{3}(3)^3 - 8(3) + C$$

$$C = 13$$

$$\therefore y = \frac{1}{3}x^3 - 8x + 13 \#$$

3) (i)

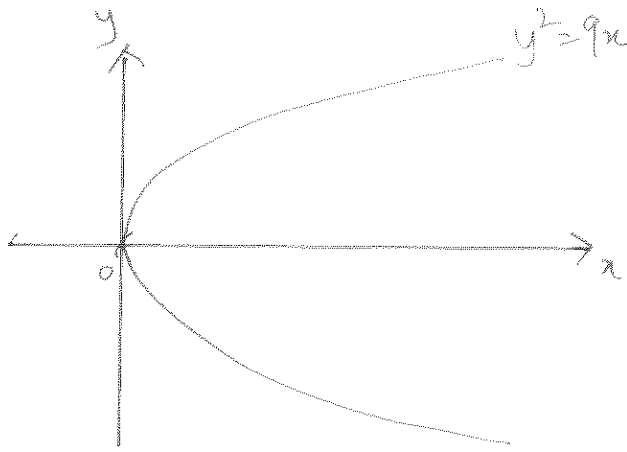

(ii) asymptotes @ $x = 3/2$

$$y = 1$$

$$\therefore h = 3/2$$

$$c = 1$$

$$\therefore y = \frac{k}{x - 3/2} + 1$$

$$\text{@ } (0, \frac{5}{3})$$

$$\frac{5}{3} = \frac{k}{0 - 3/2} + 1$$

$$k = -1$$

$$\therefore y = \frac{-1}{x - 3/2} + 1$$

$$\begin{aligned}
 \textcircled{4} \quad \frac{2x^2+x+1}{(x+1)(x-2)} &= \frac{2x^2+x+1}{x^2-x-2} \\
 &= \frac{2(x^2-x-2)+3x+5}{(x+1)(x-2)} \\
 &= 2 + \frac{3x+5}{(x+1)(x-2)} \\
 &= 2 + \frac{B}{x+1} + \frac{C}{x-2} \\
 &= 2 + \frac{B(x-2) + C(x+1)}{(x+1)(x-2)} \\
 &= 2 + \frac{(B+C)x + (-2B+C)}{(x+1)(x-2)}
 \end{aligned}$$

\therefore by comparing coefficients

$$A = 2 \quad \#$$

$$B + C = 3 \quad \textcircled{1}$$

$$-2B + C = 5 \quad \textcircled{2}$$

$\textcircled{1} - \textcircled{2}$

$$B + C - (-2B + C) = 3 - 5$$

$$3B = -2$$

$$B = -\frac{2}{3} \quad \#$$

$$\therefore -\frac{2}{3} + C = 3$$

$$C = \frac{11}{3} \quad \#$$

$$\begin{aligned}
 \textcircled{OR} \quad \frac{2x^2+x+1}{(x+1)(x-2)} &= \frac{2x^2+x+1}{x^2-x-2} \\
 x^2-x-2 \overline{) 2x^2+x+1} & \\
 \underline{-(2x^2-2x-4)} & \\
 3x+5 &
 \end{aligned}$$

$$\therefore \frac{2x^2+x+1}{(x+1)(x-2)} = 2 + \frac{3x+5}{(x+1)(x-2)}$$

(i) $y = a\sqrt{x} + \frac{b}{\sqrt{x}}$

$\therefore y\sqrt{x} = ax + b$

$\therefore Y = aX + b$

$X = x$	1	1.5	2	2.5	3	3.5
$Y = y\sqrt{x}$	2.4	4.777	7.212	10.119	12.817	15.528

(ii) draw the graph:

$b = -3$

$a = \frac{8.04}{1.5}$

$= 5.36$

Name _____ Index No. _____

Subject 5 _____ Class _____ Date _____

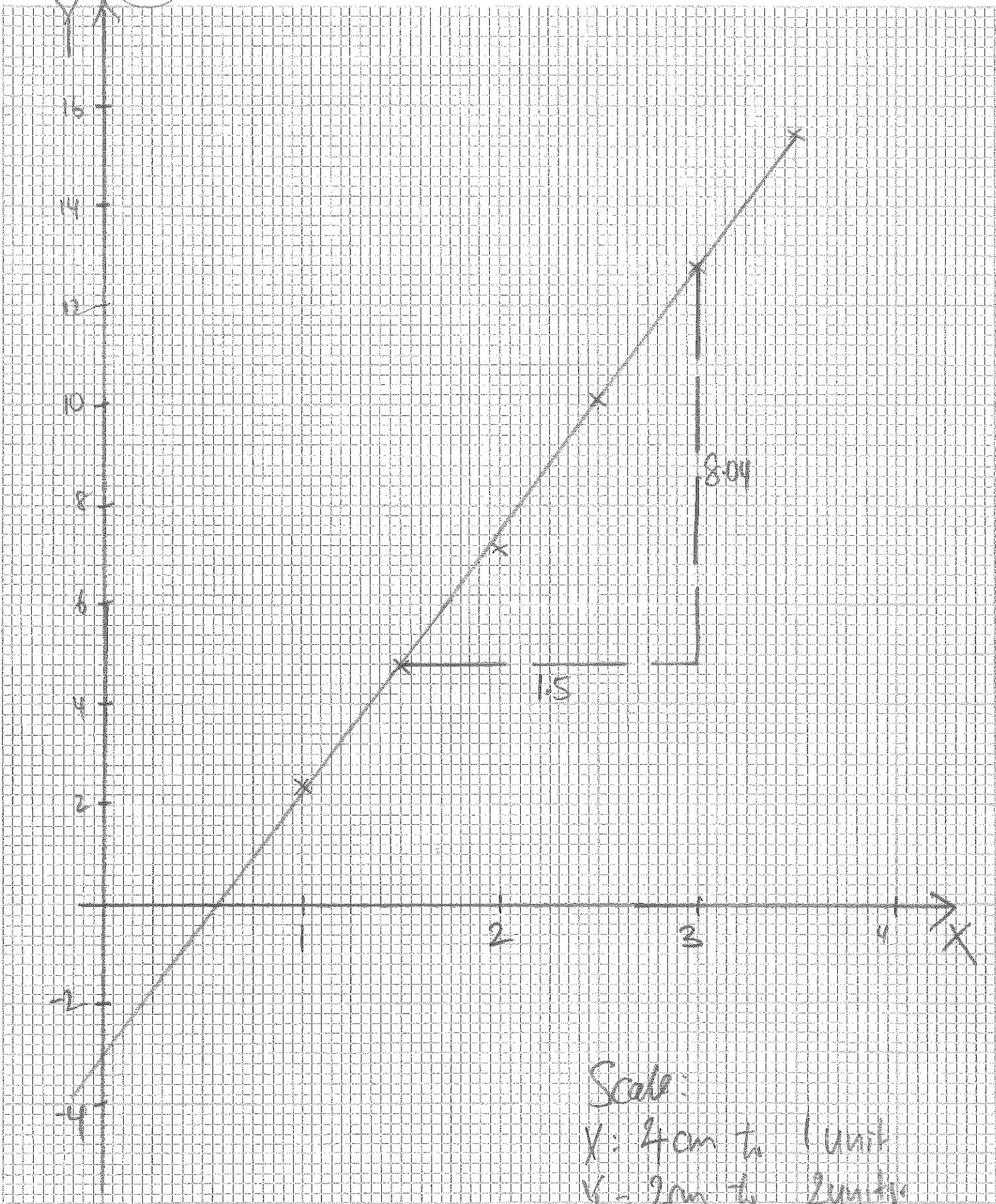

Scale:
X: 4cm to 1 unit
Y: 2cm to 2 units

$$6) 2x^2 + x + 6 = 0$$

$$\therefore \alpha + \beta = -\frac{1}{2}$$

$$\alpha\beta = \frac{6}{2} = 3$$

$$\begin{aligned}\therefore \left(\alpha + \frac{1}{2\beta}\right) + \left(\beta + \frac{1}{2\alpha}\right) &= (\alpha + \beta) + \frac{1}{2\alpha} + \frac{1}{2\beta} \\ &= (\alpha + \beta) + \frac{\beta + \alpha}{2\alpha\beta} \\ &= \left(-\frac{1}{2}\right) + \frac{-1/2}{2(3)} \\ &= -\frac{7}{12}\end{aligned}$$

$$\begin{aligned}\& \left(\alpha + \frac{1}{2\beta}\right)\left(\beta + \frac{1}{2\alpha}\right) &= \alpha\beta + \frac{1}{2} + \frac{1}{2} + \frac{1}{4\alpha\beta} \\ &= \alpha\beta + \frac{1}{4(\alpha\beta)} + 1 \\ &= 3 + \frac{1}{4(3)} + 1 \\ &= \frac{49}{12}\end{aligned}$$

\therefore the equation

$$x^2 - \left(\frac{-7}{12}\right)x + \frac{49}{12} = 0$$

$$x^2 + \frac{7}{12}x + \frac{49}{12} = 0 \quad \# \quad \text{or} \quad 12x^2 + 7x + 49 = 0 \quad \#$$

$$(ii) (\alpha - \beta)^2 = (\alpha + \beta)^2 - 4\alpha\beta$$

$$= \left(\frac{-1}{2}\right)^2 - 4(3)$$

$$= \frac{-47}{4}$$

$$< 0$$

$\therefore (\alpha - \beta)^2 \geq 0$ for all values of α & β ,

$\therefore \alpha - \beta$ is undefined. #

(OR)

$$2x^2 + x + 6 = 0$$

$$\text{roots} = \frac{-1 \pm \sqrt{-47}}{4}$$

$$= \frac{-1 + \sqrt{-47}}{4} \quad \text{or} \quad \frac{-1 - \sqrt{-47}}{4}$$

$$\therefore \alpha - \beta = \frac{-1 + \sqrt{-47}}{4} - \frac{-1 - \sqrt{-47}}{4}$$

$$= \frac{-1 + \sqrt{-47} + 1 + \sqrt{-47}}{4}$$

$$= \frac{2\sqrt{-47}}{4}$$

$\therefore (\alpha - \beta)$ is undefined because no real values exist for $\sqrt{-47}$. #

7

(i) from RHS:

$$\begin{aligned}(\operatorname{cosec} \theta - \cot \theta)^2 &= \left(\frac{1}{\sin \theta} - \frac{\cos \theta}{\sin \theta} \right)^2 \\&= \frac{(1 - \cos \theta)^2}{\sin^2 \theta} \\&= \frac{(1 - \cos \theta)^2}{1 - \cos^2 \theta} \\&= \frac{(1 - \cos \theta)^2}{(1 + \cos \theta)(1 - \cos \theta)} \\&= \frac{1 - \cos \theta}{1 + \cos \theta} \\&= \text{LHS (proven) } \# \end{aligned}$$

$$(ii) (\operatorname{cosec} \theta - \cot \theta)^2 = 5$$

$$\frac{1 - \cos \theta}{1 + \cos \theta} = 5$$

$$5 + 5 \cos \theta = 1 - \cos \theta$$

$$6 \cos \theta = -4$$

$$\cos \theta = -\frac{2}{3}$$

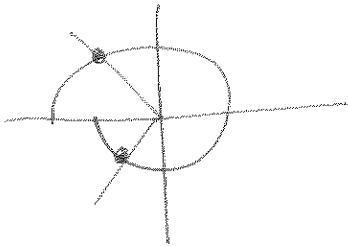

$$\text{ref } x = 0.84107 \text{ rad (to 5 DP)}$$

$$\therefore \theta = (-\pi + 0.84107) \text{ \& } (\pi - 0.84107)$$

$$= -2.30 \text{ rad} \quad \& \quad 2.30 \text{ rad (to 3 SF) } \#$$

(8)

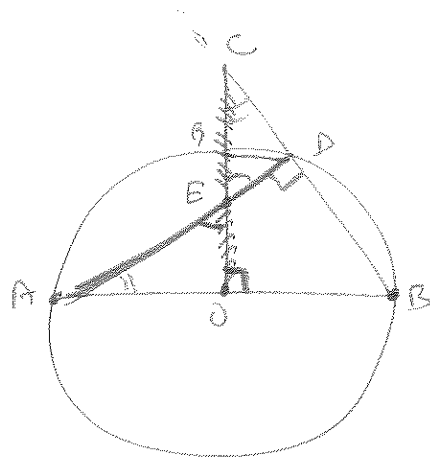

(i) $\angle ADB = 90^\circ$ (\angle s in a semicircle)

$\therefore \triangle AEO$ is similar $\triangle CED$

$\therefore \angle AEO = \angle CED$ (Vertically opposite angles)

$\angle FAO = 90^\circ - \angle AEO$ (\angle sum of triangle)

$= 90^\circ - \angle CED$

$= \angle ECD$

(or) $\angle AOE = 90^\circ$

$= \angle ADB$ (angles in semi circle)

$= \angle CDE$ (supplementary angles)

$\therefore \frac{AE}{CE} = \frac{EO}{ED} = \frac{AO}{CD}$

$\Rightarrow AE \times ED = OE \times EC$ (proven) #

(ii) $\because OG$ is perpendicular to AB (given)

& OG passes through the centre, i.e. its equidistant from A, B

\therefore all points along OG will be equidistant from A, B

& $\because C$ lies on OG produced

$\Rightarrow C$ will be equal distance from A & B (shown) #

Q iii) $\because \angle COB = 90^\circ$ (given)

$\therefore \because$ angles in semicircle $= 90^\circ$

\therefore there is a circle, with CB as its diameter that passes through point O.

$$(i) \quad 3x - y + 5 = 0$$

$$y = 3x + 5 \quad (1)$$

$$\& \quad x^2 + y^2 - 2x - 6y + 5 = 0 \quad (2)$$

Subst (1) into (2)

$$x^2 + (3x+5)^2 - 2x - 6(3x+5) + 5 = 0$$

$$x^2 + 9x^2 + 30x + 25 - 2x - 18x - 30 + 5 = 0$$

$$10x^2 + 10x = 0$$

$$10x(x+1) = 0$$

$$\therefore x = 0 \quad \text{or} \quad x = -1$$

$$(a) \quad x = 0, \quad y = 3(0) + 5 \\ = 5$$

$$\& \quad (a) \quad x = -1, \quad y = 3(-1) + 5 \\ = 2$$

$$\therefore A(0, 5) \quad \& \quad B(-1, 2)$$

$$(ii) \quad \text{gradient}(AB) = \frac{2-5}{-1-0} = 3$$

$$\text{midpoint}(AB) = \left(\frac{0+(-1)}{2}, \frac{5+2}{2} \right) = \left(-\frac{1}{2}, \frac{7}{2} \right)$$

\therefore Equation of the perpendicular bisector of AB

$$y - \frac{7}{2} = \frac{-1}{3} \left(x - \left(-\frac{1}{2} \right) \right)$$

$$y = -\frac{1}{3}x + \frac{10}{3}$$

$$(iii) x^2 + y^2 - 2x - 6y + 5 = 0$$

$$x^2 - 2x + y^2 - 6y + 5 = 0$$

$$x^2 - 2x + 1 - 1 + y^2 - 2(3y) + 3^2 - 3^2 + 5 = 0$$

$$(x-1)^2 + (y-3)^2 = 5$$

@ (1,1)

$$\therefore (1-1)^2 + (1-3)^2 = 4$$

$$< 5$$

\therefore point (1,1) lies inside the circumference of the circle. #

$$\textcircled{10} \quad \widehat{AB} = \frac{1}{4} [2\pi(x)] \quad \& \quad BC^2 = x^2 + x^2 \quad (\text{Pythagoras' Theorem})$$

$$= \frac{\pi}{2} x \quad BC = \sqrt{2x^2} \quad (BC > 0)$$

$$= x\sqrt{2}$$

$$\therefore x + y + x + x\sqrt{2} + y + \frac{\pi}{2}x = 680$$

$$2y + (2 + \frac{\pi}{2} + \sqrt{2})x = 680$$

$$y = \frac{680 - (2 + \frac{\pi}{2} + \sqrt{2})x}{2} \quad \textcircled{1}$$

$$\& \quad \text{Area} = \frac{1}{4} [\pi(x)^2] + \frac{1}{2} (y + y + x)(x)$$

$$= \frac{\pi}{4} x^2 + \frac{x}{2} (2y + x)$$

$$= \frac{\pi}{4} x^2 + \frac{x}{2} \left[2 \left(\frac{680 - (2 + \frac{\pi}{2} + \sqrt{2})x}{2} \right) + x \right]$$

$$= \frac{\pi}{4} x^2 + \frac{x}{2} \left[680 - (2 + \frac{\pi}{2} + \sqrt{2})x + x \right]$$

$$= \frac{\pi}{4} x^2 + 340x - \frac{x^2}{2} (2 + \frac{\pi}{2} + \sqrt{2}) + \frac{x^2}{2}$$

$$= 340x + \left[\frac{\pi}{4} - \frac{1}{2} (2 + \frac{\pi}{2} + \sqrt{2}) + \frac{1}{2} \right] x^2$$

$$= 340x + \left[-\frac{1}{2} - \frac{\sqrt{2}}{2} \right] x^2$$

$$= 340x - \left(\frac{1 + \sqrt{2}}{2} \right) x^2 \quad (\text{shown}) \quad \#$$

$$(i) \text{ Area} = 340x - \left(\frac{1+\sqrt{2}}{2}\right)x^2$$

$$\frac{d\text{Area}}{dx} = 340 - 2\left(\frac{1+\sqrt{2}}{2}\right)x$$

$$= 340 - (1+\sqrt{2})x$$

$$\frac{d^2\text{Area}}{dx^2} = -(1+\sqrt{2})$$

$$< 0$$

\therefore Area will be maximized at stationary point -

\therefore Maximum value of x @ $\frac{d\text{Area}}{dx} = 0$

$$\therefore 340 - (1+\sqrt{2})x = 0$$

$$x = \frac{340}{1+\sqrt{2}}$$

$$= 140.83 \text{ m (to 2 DP)} \quad \#$$

$$\textcircled{\text{II}} \quad v = (3t + 5)(t - 5) = 3t^2 - 10t - 25$$

$$(i) \quad @ \quad v = 0$$

$$(3t + 5)(t - 5) = 0$$

$$\therefore t = -\frac{5}{3} \quad \& \quad t = 5 \text{ sec} \#$$

$$(NA \because t > 0)$$

$$(ii) \quad s = \int 3t^2 - 10t - 25 \, dt$$

$$= t^3 - 5t^2 - 25t + C$$

$$@ \quad t = 0, \quad s = 0, \quad \therefore C = 0$$

$$\therefore s = t^3 - 5t^2 - 25t$$

$$= t(t^2 - 5t - 25)$$

$$@ \quad s = 0$$

$$t = 0 \quad \text{or} \quad t^2 - 5t - 25 = 0$$

$$t = \frac{5 \pm \sqrt{125}}{2}$$

$$= \frac{5 \pm 5\sqrt{5}}{2}$$

$$= 8.09 \text{ sec} \quad \text{or} \quad -3.09 \quad (t \text{ 3SF}) \\ (NA)$$

\therefore particle will pass through the origin again @ $t = 8.09 \text{ sec} \#$

(iii)

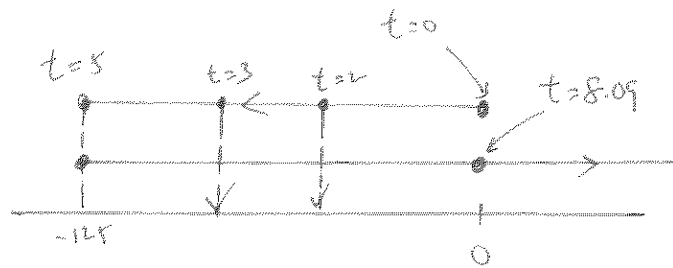

$$\text{@ } t=2, S = 2(2^2 - 5(2) - 25) = -62 \text{ m}$$

$$\text{@ } t=3, S = 3(3^2 - 5(3) - 25) = -93 \text{ m}$$

\therefore distance travelled = 31 m #

(or)

$$\begin{aligned} \text{Distance} &= \int_3^2 (3t^2 - 10t - 25) dt \\ &= \left[t^3 - 5t^2 - 25t \right]_3^2 \\ &= [-62] - [-93] \\ &= 31 \text{ m} \# \end{aligned}$$

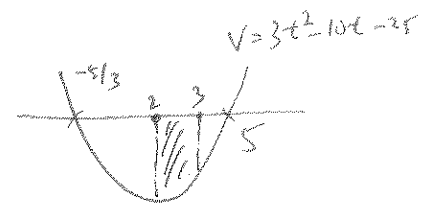

(iv) Velocity decreasing $\Rightarrow a < 0$

$\therefore a = \text{acceleration}$

$$= \frac{dv}{dt}$$

$$= 6t - 10$$

$$\therefore 6t - 10 < 0$$

$$t < \frac{5}{3}$$

$$\therefore 0 < t < \frac{5}{3} \#$$

12

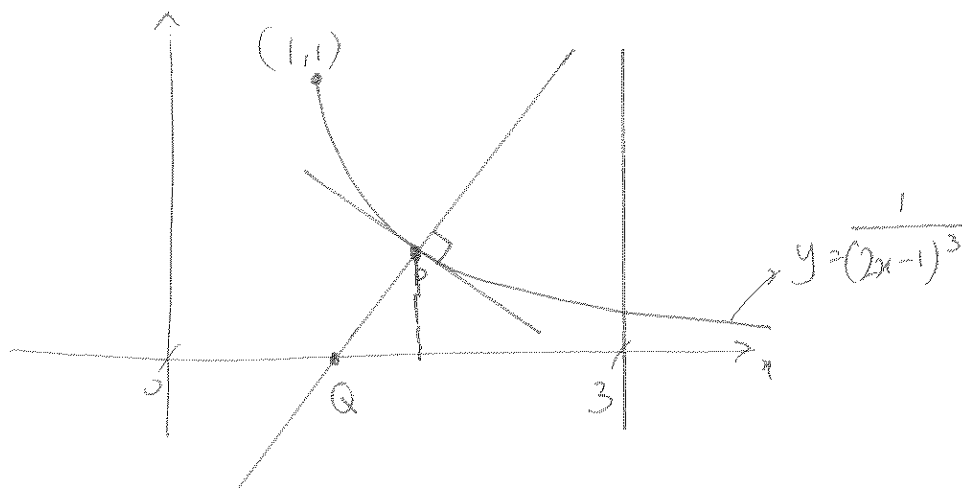

(i) $y = (2x-1)^{-3}$

$$\begin{aligned}\therefore \frac{dy}{dx} &= -3(2x-1)^{-4} \cdot [2] \\ &= \frac{-6}{(2x-1)^4}\end{aligned}$$

(a) $x = \frac{3}{2}$,

$$\begin{aligned}\text{gradient} &= \frac{dy}{dx} = -6 \\ &= \frac{-6}{\left[2\left(\frac{3}{2}\right) - 1\right]^4} \\ &= \frac{-6}{8}\end{aligned}$$

\therefore the equation of the normal @ P

$$y - \frac{1}{8} = \frac{8}{5}\left(x - \frac{3}{2}\right)$$

$$y = \frac{8}{3}x - \frac{31}{8}$$

(ii) @ $y=0$

$$x = \frac{93}{64}$$

$$\therefore Q\left(\frac{93}{64}, 0\right)$$

$$\therefore OQ = \frac{93}{64} \text{ units}$$

(iii)

$$Area = \frac{1}{2} \left(\frac{3}{2} - \frac{93}{64} \right) \left(\frac{1}{8} \right) + \int_{3/2}^3 (2x-1)^{-3} dx$$

$$= \frac{3}{1024} + \left[\frac{(2x-1)^{-2}}{(-2)(2)} \right]_{3/2}^3$$

$$= \frac{3}{1024} + \left[\frac{-1}{4(2x-1)^2} \right]_{3/2}^3$$

$$= \frac{3}{1024} + \left[\frac{-1}{4[2(3)-1]^2} - \frac{-1}{4[2(\frac{3}{2})-1]^2} \right]$$

$$= \frac{3}{1024} + \left[\frac{-1}{100} + \frac{1}{16} \right]$$

$$= \frac{1419}{25600}$$

$$= 0.0554 \text{ units}^2 \text{ (to 3SF)} \quad (\text{Sham})$$



**SECONDARY 4
2018 Preliminary Examinations**

**ADDITIONAL MATHEMATICS
Paper 2**

4047/2

12 September 2018 (Wednesday)

2 hours 30 minutes

CANDIDATE
NAME

CLASS

INDEX
NUMBER

<input type="text"/>	<input type="text"/>
----------------------	----------------------

READ THESE INSTRUCTIONS FIRST

Do not turn over the page until you are told to do so.
Write your name, class and index number in the spaces above.
Write in dark blue or black pen in the writing papers provided.

You may use a pencil for any diagrams or graphs.
Do not use paper clips, highlighters, glue or correction fluid.

INFORMATION FOR CANDIDATES

Answer **all** the questions.

Give non-exact numerical answers correct to 3 significant figures, or 1 decimal place in the case of angles in degrees, unless a different level of accuracy is specified in the question.

The use of a scientific calculator is expected, where appropriate.

You are reminded of the need for clear presentation in your answers.

At the end of the examination, fasten all your answer scripts securely together.

The number of marks is given in brackets [] at the end of each question or part question.

The total number of marks for this paper is **100**.

For Examiner's Use		
Q1	4	
Q2	6	
Q3	6	
Q4	6	
Q5	7	
Q6	8	
Q7	8	
Q8	9	
Q9	10	
Q10	10	
Q11	13	
Q12	13	
Total		/100

Mathematical Formulae

1. ALGEBRA

Quadratic Equation

For the equation $ax^2 + bx + c = 0$,

$$x = \frac{-b \pm \sqrt{b^2 - 4ac}}{2a}$$

Binomial Expansion

$$(a + b)^n = a^n + \binom{n}{1} a^{n-1} b + \binom{n}{2} a^{n-2} b^2 + \dots + \binom{n}{r} a^{n-r} b^r + \dots + b^n$$

where n is a positive integer and $\binom{n}{r} = \frac{n!}{r!(n-r)!} = \frac{n(n-1)\dots(n-r+1)}{r!}$

2. TRIGONOMETRY

Identities

$$\sin^2 A + \cos^2 A = 1$$

$$\sec^2 A = 1 + \tan^2 A$$

$$\operatorname{cosec}^2 A = 1 + \cot^2 A$$

$$\sin(A \pm B) = \sin A \cos B \pm \cos A \sin B$$

$$\cos(A \pm B) = \cos A \cos B \mp \sin A \sin B$$

$$\tan(A \pm B) = \frac{\tan A \pm \tan B}{1 \mp \tan A \tan B}$$

$$\sin 2A = 2 \sin A \cos A$$

$$\cos 2A = \cos^2 A - \sin^2 A = 2 \cos^2 A - 1 = 1 - 2 \sin^2 A$$

$$\tan 2A = \frac{2 \tan A}{1 - \tan^2 A}$$

Formulae for ΔABC

$$\frac{a}{\sin A} = \frac{b}{\sin B} = \frac{c}{\sin C}$$

$$a^2 = b^2 + c^2 - 2bc \cos A$$

$$\Delta = \frac{1}{2} ab \sin C$$

- 1 Find the value of the constant k for which $y = x^2 e^{1-2x}$ is a solution of the equation

$$\frac{d^2 y}{dx^2} - \frac{2y}{x^2} = k \left(\frac{dy}{dx} + y \right).$$

[4]

- 2 (i) Find $\frac{d}{dx} \left(\frac{\ln x}{x} \right)$.

[2]

(ii) Hence find $\int \frac{\ln x}{x^2} dx$.

[3]

The curve $y = f(x)$ is such that $f(x) = \frac{\ln x}{x}$, for $x > 0$.

(iii) Explain why the curve $y = f(x)$ has only one stationary point.

[1]

- 3 The expression $2x^3 + ax^2 + bx - 35$, where a and b are constants, has a factor of $2x - 7$ and leaves a remainder of -36 when divided by $x + 1$.

(i) Find the value of a and of b .

[4]

(ii) Using the values of a and b found in part (i), explain why the equation

$$2x^3 + ax^2 + bx - 35 = 0 \text{ has only one real root.}$$

[2]

- 4 As part of his job in a restaurant, John learned to cook a hot pot of soup late at night so that there would be enough for sale the next day. While refrigeration was essential to preserve the soup overnight, the soup was too hot to be put directly in the refrigerator when it was ready at 100°C . The soup subsequently cooled in such a way that its temperature, $x^\circ\text{C}$ after t minutes, was given by the expression $x = 20 + Ae^{-kt}$, where A and k are constants.

(i) Explain why $A = 80$.

[1]

(ii) When $t = 15$, the temperature of the soup is 58°C .

Find the value of k .

[2]

(iii) Deduce the temperature of the soup if it is left unattended for a long period of time, giving a reason for your answer.

[1]

(iv) For the soup to be refrigerated, its temperature should be less than 35°C .

What is the shortest possible time, correct to the nearest minute, that John has to wait before he could refrigerate the soup?

[2]

- 5 (a) The function f is defined, for all values of x , by

$$f(x) = x^2(3 - 4x).$$

Find the range of values of x for which f is an increasing function. [3]

- (b) A particle moves along the curve $y = \frac{16}{(3 - 4x)^2}$ in such a way that the y -coordinate of the particle is increasing at a constant rate of 0.03 units per second. Find the exact y -coordinate of the particle at the instant that the x -coordinate of the particle is decreasing at 0.12 units per second. [4]

- 6 (a) (i) Sketch the graph of $y = 10^x$. [1]

- (ii) Given that $\frac{4^x}{2^{x+2}} = \frac{3}{5^x}$, find the value of 10^x . [2]

- (b) Solve the equation $\log_2 \sqrt{5x+1} + 2\log_9 3 = \log_4(2x-3) + \log_3 27$. [5]

- 7 The population of a herd of deer can be modelled by the function $D = 400 + 40 \sin\left(\frac{\pi}{6}t\right)$, where D is the deer population in week t of the year for $0 \leq t \leq 24$.

Using the model,

- (i) state the amplitude of the function, [1]

- (ii) state the period of the function, [1]

- (iii) find the maximum and minimum values of D , [1]

- (iv) sketch the function $D = 400 + 40 \sin\left(\frac{\pi}{6}t\right)$ for $0 \leq t \leq 24$. [2]

- (v) estimate the number of weeks for $0 \leq t \leq 24$ that the population is greater than 420. [3]

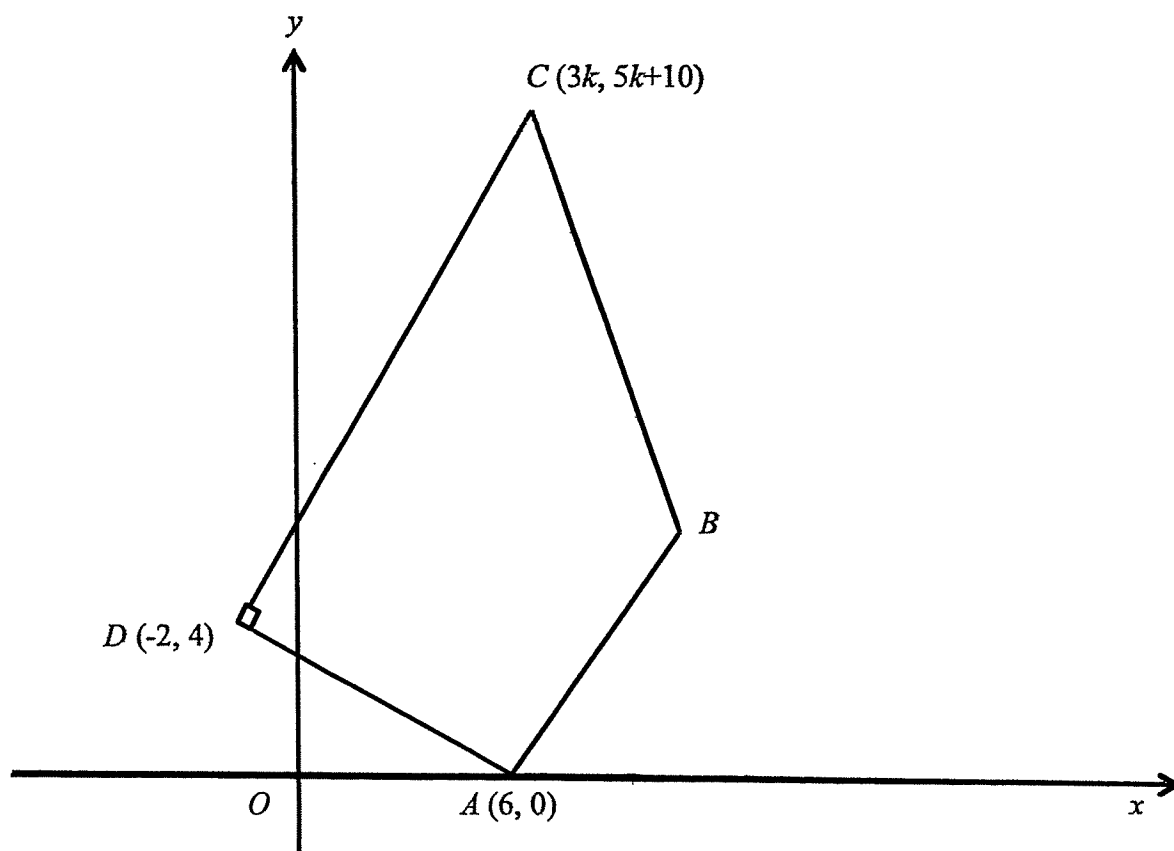

The diagram shows a quadrilateral $ABCD$ in which A is $(6, 0)$, C is $(3k, 5k + 10)$ and D is $(-2, 4)$. The equation of line AB is $y = 2x - 12$ and angle $ADC = 90^\circ$.

(i) Find the value of k . [3]

Given that the perpendicular bisector of CD passes through B , find

(ii) the coordinates of B , [4]

(iii) the area of the quadrilateral $ABCD$. [2]

9 (a) The first three terms in the binomial expansion of $(1 + px)^n$ are $1 - 48x + 960x^2$.
Find the value of p and of n . [4]

(b) In the expansion of $\left(2x^2 + \frac{a}{x}\right)^8$, where a is a non-zero real number, the ratio of the coefficient of the 3rd term to that of the 5th term is 5 : 2.

(i) Find the possible values of a . [4]

(ii) Explain whether the term independent of x exists for the expansion

of $\left(2x^2 + \frac{a}{x}\right)^8$. [2]

10

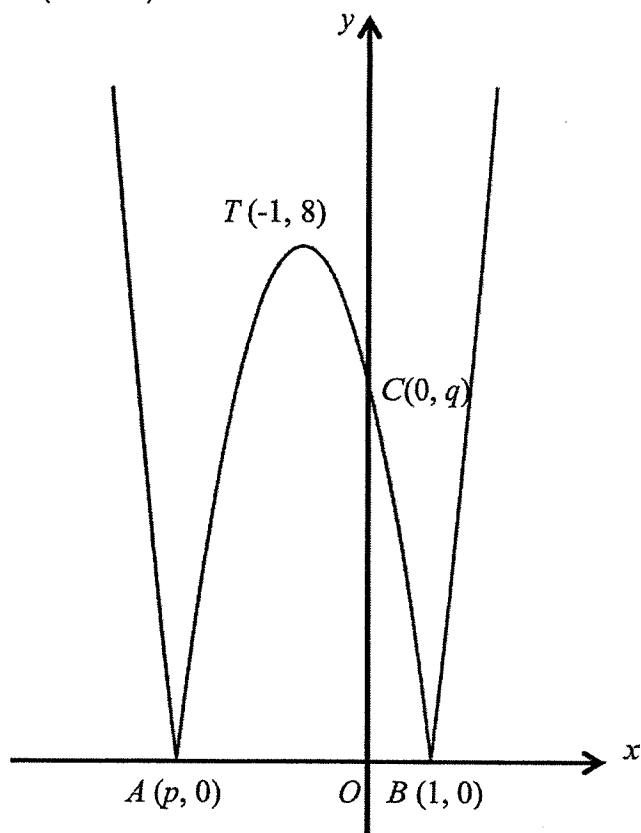

The diagram shows part of the curve $y = |ax^2 + bx + c|$ where $a < 0$.

The curve touches the x -axis at $A(p, 0)$ and at $B(1, 0)$.

The curve touches the y -axis at $C(0, q)$ and has a maximum point at $T(-1, 8)$.

(i) Explain why $p = -3$. [1]

(ii) Determine the value of a , b , c and q . [4]

(iii) State the range of values of r for which the line $y = r$ intersects the curve $y = |ax^2 + bx + c|$ at four distinct points. [1]

(iv) In the case where $r = 2$, find the exact x -coordinates of all points of intersection of the line $y = r$ and the curve $y = |ax^2 + bx + c|$. [4]

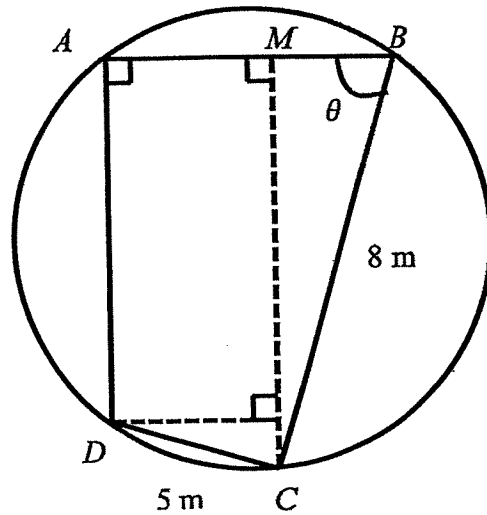

The diagram shows a circular garden. A farmer decides to fence part of the garden. He puts fences around the perimeter $ABCD$ such that $BC = 8$ m, $CD = 5$ m, angle $DAB = 90^\circ$ and angle $ABC = \theta$ where $0^\circ < \theta < 90^\circ$.

- (i) Given that CM is perpendicular to AB , express CM and AB in terms of θ . [4]
- (ii) Show that L m, the length of fencing needed for perimeter $ABCD$, is given by $L = 13 + 3\cos\theta + 13\sin\theta$. [2]
- (iii) Express L in the form $13 + R\cos(\theta - \alpha)$ where $R > 0$ and α is an acute angle. [4]
- (iv) Given that the farmer uses exactly 26.2 m of fencing, find the possible values of θ . [3]

- 12 (a) It is given that $\int f(x)dx = k \cos 2x - \sin 3x + c$, where c is a constant of integration, and that $\int_0^{\frac{\pi}{6}} f(x)dx = \frac{1}{3}$.
- (i) Show that $k = -2\frac{2}{3}$. [1]
- (ii) Find $f(x)$. [2]
- (b) A curve has the equation $y = g(x)$, where $g(x) = 2\sin^2 x - \sin 2x$ for $0 \leq x \leq \pi$.
- (i) Find the x -coordinates of the stationary points of the curve. [3]
- (ii) Use the second derivative test to determine the nature of each of these points. [3]
- (iii) Given that $\int g(x)dx = ax + b \sin x \cos x + \cos^2 x + k$, where k is a constant of integration, find the value of a and of b . [4]

END OF PAPER



SECONDARY 4
2018 Preliminary Examinations

ADDITIONAL MATHEMATICS
Paper 2

4047/2

12 September 2018 (Wednesday)

2 hours 30 minutes

CANDIDATE
NAME

Solutions

CLASS

--

INDEX
NUMBER

--	--

READ THESE INSTRUCTIONS FIRST

Do not turn over the page until you are told to do so.
Write your name, class and index number in the spaces above.
Write in dark blue or black pen in the writing papers provided.

You may use a pencil for any diagrams or graphs.
Do not use paper clips, highlighters, glue or correction fluid.

INFORMATION FOR CANDIDATES

Answer **all** the questions.

Give non-exact numerical answers correct to 3 significant figures, or 1 decimal place in the case of angles in degrees, unless a different level of accuracy is specified in the question.

The use of a scientific calculator is expected, where appropriate.

You are reminded of the need for clear presentation in your answers.

At the end of the examination, fasten all your answer scripts securely together.

The number of marks is given in brackets [] at the end of each question or part question.

The total number of marks for this paper is **100**.

For Examiner's Use		
Q1	4	
Q2	6	
Q3	6	
Q4	6	
Q5	7	
Q6	8	
Q7	8	
Q8	9	
Q9	10	
Q10	10	
Q11	13	
Q12	13	
Total		/100

Mathematical Formulae

1. ALGEBRA

Quadratic Equation

For the equation $ax^2 + bx + c = 0$,

$$x = \frac{-b \pm \sqrt{b^2 - 4ac}}{2a}$$

Binomial Expansion

$$(a + b)^n = a^n + \binom{n}{1} a^{n-1} b + \binom{n}{2} a^{n-2} b^2 + \dots + \binom{n}{r} a^{n-r} b^r + \dots + b^n$$

where n is a positive integer and $\binom{n}{r} = \frac{n!}{r!(n-r)!} = \frac{n(n-1)\dots(n-r+1)}{r!}$

2. TRIGONOMETRY

Identities

$$\sin^2 A + \cos^2 A = 1$$

$$\sec^2 A = 1 + \tan^2 A$$

$$\operatorname{cosec}^2 A = 1 + \cot^2 A$$

$$\sin(A \pm B) = \sin A \cos B \pm \cos A \sin B$$

$$\cos(A \pm B) = \cos A \cos B \mp \sin A \sin B$$

$$\tan(A \pm B) = \frac{\tan A \pm \tan B}{1 \mp \tan A \tan B}$$

$$\sin 2A = 2 \sin A \cos A$$

$$\cos 2A = \cos^2 A - \sin^2 A = 2 \cos^2 A - 1 = 1 - 2 \sin^2 A$$

$$\tan 2A = \frac{2 \tan A}{1 - \tan^2 A}$$

Formulae for ΔABC

$$\frac{a}{\sin A} = \frac{b}{\sin B} = \frac{c}{\sin C}$$

$$a^2 = b^2 + c^2 - 2bc \cos A$$

$$\Delta = \frac{1}{2} ab \sin C$$

1 Find the value of the constant k for which $y = x^2 e^{1-2x}$ is a solution of the equation

$$\frac{d^2 y}{dx^2} - \frac{2y}{x^2} = k \left(\frac{dy}{dx} + y \right).$$

[4]

Solution

$$y = x^2 e^{1-2x}$$

$$\frac{dy}{dx} = x^2 (-2e^{1-2x}) + e^{1-2x} (2x)$$

$$= -2x^2 e^{1-2x} + 2x e^{1-2x}$$

$$= -2y + 2x e^{1-2x} = -2y + \frac{2y}{x}$$

$$\frac{d^2 y}{dx^2} = -2 \frac{dy}{dx} + 2x (-2e^{1-2x}) + 2e^{1-2x}$$

$$= -2 \frac{dy}{dx} - 4x e^{1-2x} + 2e^{1-2x}$$

$$= -2 \frac{dy}{dx} - \frac{4y}{x} + \frac{2y}{x^2}$$

$$\frac{d^2 y}{dx^2} - \frac{2y}{x^2}$$

$$= -2 \frac{dy}{dx} - \frac{4y}{x}$$

$$= -2 \frac{dy}{dx} - 2 \left(\frac{dy}{dx} + 2y \right)$$

$$= -4 \frac{dy}{dx} - 4y$$

$$= -4 \left(\frac{dy}{dx} + y \right)$$

$$k = -4$$

2 (i) Find $\frac{d}{dx}\left(\frac{\ln x}{x}\right)$.

[2]

Solution

$$\begin{aligned} \frac{d}{dx}\left(\frac{\ln x}{x}\right) \\ &= \frac{x\left(\frac{1}{x}\right) - \ln x}{x^2} \\ &= \frac{1 - \ln x}{x^2} \end{aligned}$$

(ii) Hence find $\int \frac{\ln x}{x^2} dx$.

[3]

Solution

From (i),

$$\begin{aligned} \int \frac{1 - \ln x}{x^2} dx &= \frac{\ln x}{x} + C \\ \int \frac{1}{x^2} dx - \int \frac{\ln x}{x^2} dx &= \frac{\ln x}{x} + C \\ -\frac{1}{x} - \int \frac{\ln x}{x^2} dx &= \frac{\ln x}{x} + C \\ \int \frac{\ln x}{x^2} dx &= \frac{-1}{x} - \frac{\ln x}{x} + D \end{aligned}$$

The curve $y = f(x)$ is such that $f(x) = \frac{\ln x}{x}$, for $x > 0$.

(iii) **Explain** why the curve $y = f(x)$ has only one stationary point.

[1]

Solution

$$\begin{aligned} f(x) &= \frac{\ln x}{x} \\ f'(x) &= \frac{1 - \ln x}{x^2} \end{aligned}$$

For stationary point to exist, $f'(x) = 0$

$$1 - \ln x = 0$$

$$\ln x = 1$$

$$x = e$$

For $x > 0$, $y = f(x)$ has only 1 stationary point at $x = e$.

3 The expression $2x^3 + ax^2 + bx - 35$, where a and b are constants, has a factor of $2x - 7$ and leaves a remainder of -36 when divided by $x + 1$.

(i) Find the value of a and of b . [4]

(ii) Using the values of a and b found in part (i), **explain** why the equation $2x^3 + ax^2 + bx - 35 = 0$ has only one real root. [2]

Solution

(i)

$$f(x) = 2x^3 + ax^2 + bx - 35$$

$$f\left(\frac{7}{2}\right) = 0$$

$$2\left(\frac{7}{2}\right)^3 + a\left(\frac{7}{2}\right)^2 + b\left(\frac{7}{2}\right) - 35 = 0$$

$$\frac{343}{4} + \frac{49}{4}a + \frac{7b}{2} - 35 = 0$$

$$\frac{49a}{4} + \frac{7b}{2} = \frac{-203}{4}$$

$$49a + 14b = -203 \text{-----(1)}$$

$$f(-1) = -36$$

$$2(-1)^3 + a(-1)^2 + b(-1) - 35 = -36$$

$$-2 + a - b - 35 = -36$$

$$a - b = 1 \text{-----(2)}$$

$$49(1+b) + 14b = -203$$

$$49 + 63b = -203$$

$$63b = -252$$

$$b = -4$$

$$a = b + 1 = -4 + 1 = -3$$

(ii) $2x^3 - 3x^2 - 4x - 35 = 0$

$$2x^3 + ax^2 + bx - 35 = (2x - 7)(x^2 + 2x + 5) = 0$$

For $x^2 + 2x + 5$, since $(2)^2 - 4(1)(20) < 0$ and the coefficient of x^2 is always positive, $x^2 + 2x + 5$ is always positive.

4 As part of his job in a restaurant, John learned to cook a hot pot of soup late at night so that there would be enough for sale the next day. While refrigeration was essential to preserve the soup overnight, the soup was too hot to be put directly in the refrigerator when it was ready at 100°C . The soup subsequently cools in such

a way that its temperature, $x^\circ\text{C}$ after t minutes, is given by the expression $x = 20 + Ae^{-kt}$, where A and k are constants.

(i) **Explain** why $A = 80$.

[1]

Solution

Since the soup is ready at 100°C initially,

$$\text{At } t = 0, x = 20 + Ae^0 = 100$$

$$A = 80$$

(ii) When $t = 15$, the temperature of the soup is 58°C .

Find the value of k .

[2]

Solution

$$58 = 20 + 80e^{-k(15)}$$

$$38 = 80e^{-15k}$$

$$e^{-15k} = \frac{38}{80}$$

$$-15k = \ln \frac{38}{80}$$

$$k = 0.0496$$

(iii) Deduce the temperature of the soup if it is left unattended for a long period of time, **giving a reason** for your answer.

[1]

Solution

For $x = 20 + 80e^{-kt}$, as $t \rightarrow \infty$, $e^{-kt} \rightarrow 0$

Temperature of the soup approaches 20°C

if it is left unattended for a long period of time.

- 4 (iv) For the soup to be refrigerated, its temperature should be less than 35°C .
What is the shortest possible time, correct to the nearest minute that John
has to wait before he can refrigerate the soup?

[2]

Solution

$$20 + 80e^{-\left(\frac{80}{15}\right)t} = 35$$

$$80e^{\frac{\ln 38}{15}t} = 15$$

$$e^{\frac{\ln 38}{15}t} = \frac{15}{80}$$

$$\frac{\ln 38}{15}t = \ln \frac{15}{80}$$

$$t = 33.7$$

Shortest possible time = 34 minutes

- 5 (a) The function f is defined, for all values of x , by

$$f(x) = x^2(3 - 4x).$$

Find the values of x for which f is an increasing function.

[3]

Solution

$$f(x) = 3x^2 - 4x^3$$

$$f'(x) = 6x - 12x^2$$

For f to be an increasing function,

$$f'(x) > 0$$

$$6x - 12x^2 > 0$$

$$6x(1 - 2x) > 0$$

$$0 < x < \frac{1}{2}$$

5 (b) A particle moves along the curve $y = \frac{16}{(3-4x)^2}$ in such a way that the y -coordinate of the particle is increasing at a constant rate of 0.03 units per second. Find the exact y -coordinate of the particle at the instant that the x -coordinate of the particle is decreasing at 0.12 units per second.

[4]

Solution

$$y = \frac{16}{(3-4x)^2} = 16(4-4x)^{-2}$$

$$\frac{dy}{dx} = -32(3-4x)^{-3}(-4) = \frac{128}{(3-4x)^3}$$

$$\frac{dy}{dt} = 0.03$$

$$\frac{dy}{dt} = \frac{dy}{dx} x \frac{dx}{dt}$$

$$0.03 = \frac{128}{(3-4x)^3} (-0.12)$$

$$(3-4x)^3 = -512$$

$$3-4x = -8$$

$$-4x = -11$$

$$x = \frac{11}{4}$$

$$y = \frac{16}{(3-4(\frac{11}{4}))^2} = \frac{1}{4}$$

6 (a) (i) Sketch the graph of $y = 10^x$. [1]

(ii) Given that $\frac{4^x}{2^{x+2}} = \frac{3}{5^x}$, find the value of 10^x . [2]

Solution

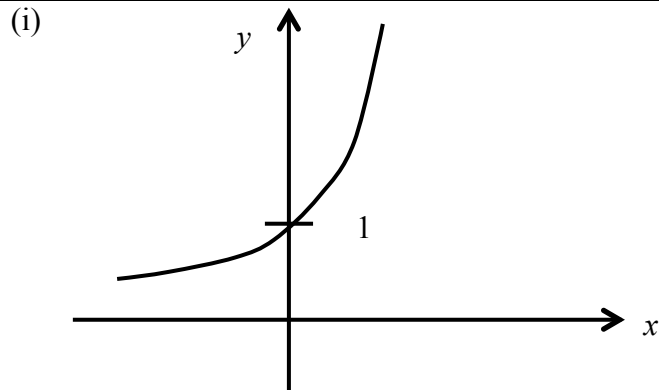

(ii) $\frac{4^x}{2^{x+2}} = \frac{3}{5^x}$

$$\frac{2^{2x}}{2^{x+2}} = \frac{3}{5^x}$$

$$2^{2x-(x+2)}5^x = 3$$

$$2^{x-2}5^x = 3$$

$$\frac{2^x}{4}(5^x) = 3$$

$$10^x = 12$$

(b) Solve the equation $\log_2 \sqrt{5x+1} + 2\log_9 3 = \log_4(2x-3) + \log_3 27$. [5]

Solution

$$\log_2 \sqrt{5x+1} + 2\log_9 3 = \log_4(2x-3) + \log_3 27$$

$$\log_2 \sqrt{5x+1} = \log_4(2x-3) + 3 - 1$$

$$\log_2 \sqrt{5x+1} = \frac{\log_2(2x-3)}{\log_2 2^2} + \log_2 2^2$$

$$\log_2 \sqrt{5x+1} = \log_2(2x-3)^{\frac{1}{2}} + \log_2 4$$

$$\sqrt{5x+1} = 4\sqrt{2x-3}$$

$$5x+1 = 16(2x-3)$$

$$5x+1 = 32x-48$$

$$27x = 49$$

$$x = \frac{49}{27}$$

or $x=1.81$ (3sf)

- 7 The population of a herd of deer can be modelled by the function $D = 400 + 40 \sin\left(\frac{\pi}{6}t\right)$, where D is the deer population in week t of the year for $0 \leq t \leq 24$.

Using the model,

- (i) state the amplitude of the function, [1]
- (ii) state the period of the function, [1]
- (iii) find the maximum and minimum values of D , [2]
- (iv) sketch the function $D = 400 + 40 \sin\left(\frac{\pi}{6}t\right)$ for $0 \leq t \leq 24$. [2]
- (v) estimate the number of weeks for $0 \leq t \leq 24$ that the population is greater than 420. [3]

Solution

(i) $D = 400 + 40 \sin\left(\frac{\pi}{6}t\right)$ for $0 \leq t \leq 24$

Amplitude = 40

(ii) Period = $\frac{2\pi}{\frac{\pi}{6}} = 12$

(iii) Maximum $D = 400 + 40 = 440$

Minimum $D = 400 - 40 = 360$

(iv)

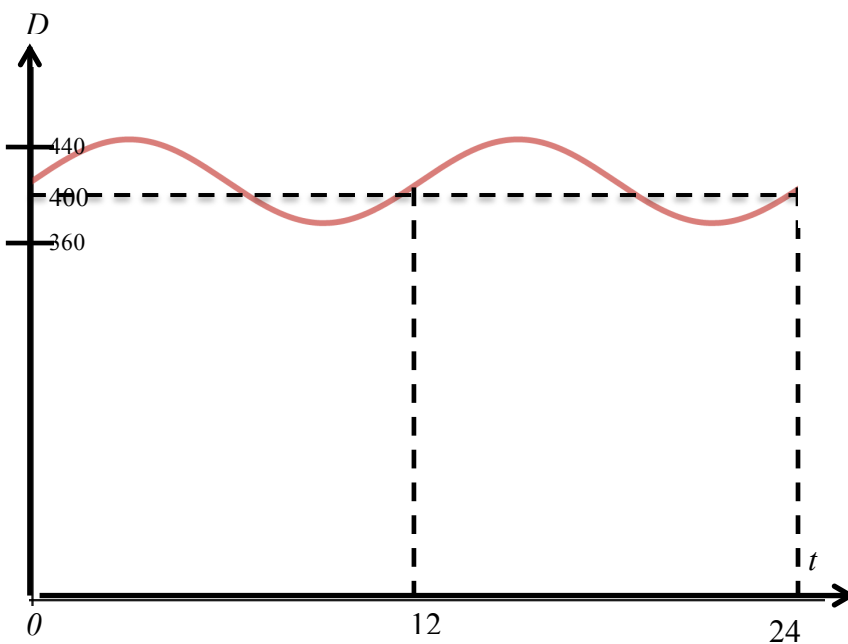

(v) $400 + 40 \sin\left(\frac{\pi}{6}t\right) = 420$

$$40\sin\left(\frac{\pi}{6}t\right)=20$$

$$\sin\left(\frac{\pi}{6}t\right)=0.5$$

$$\text{Basic angle} = \frac{\pi}{6}$$

$$\frac{\pi}{6}t = \frac{\pi}{6}, \frac{5\pi}{6}, \frac{13\pi}{6}, \frac{17\pi}{6}$$

$$t = 1, 5, 13, 17$$

$$\text{No of weeks} = (5-1) + (17-13) = 8$$

8

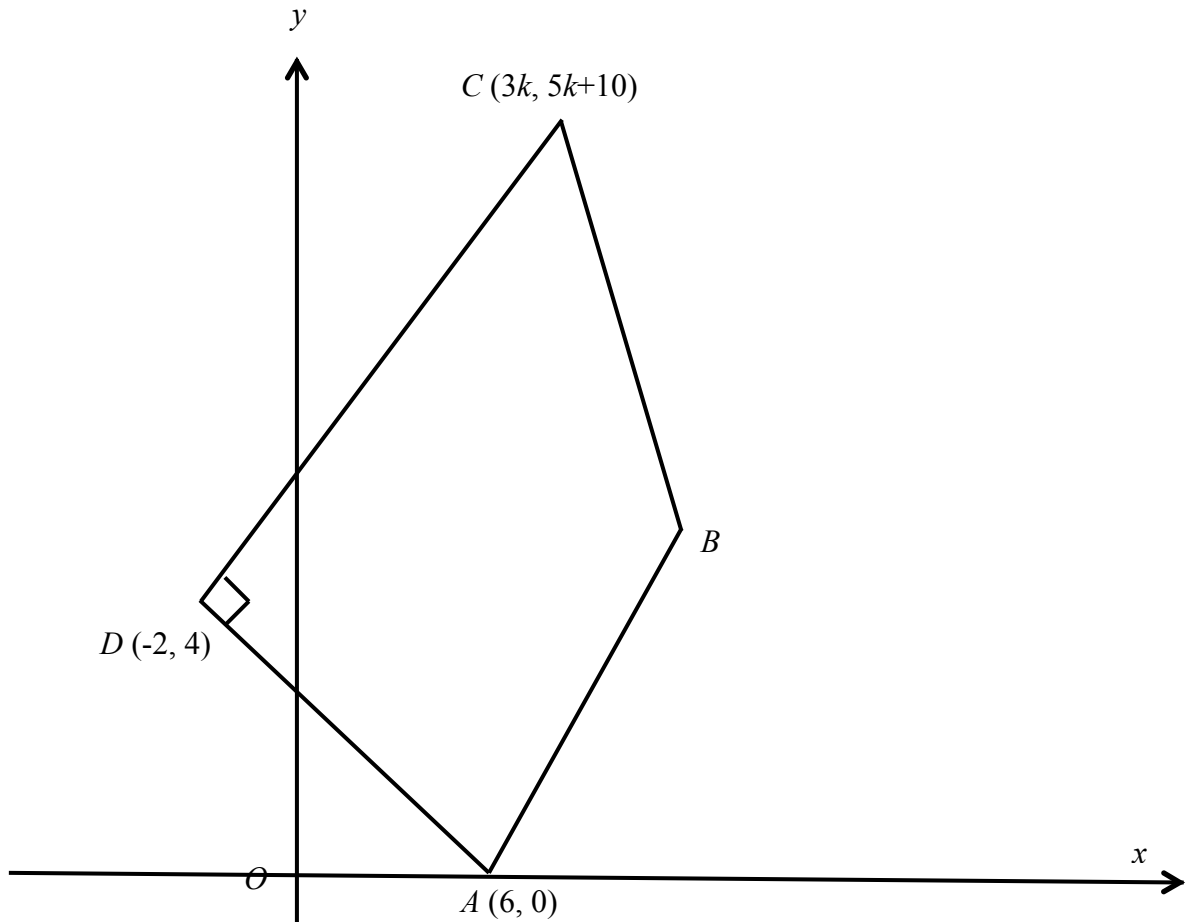

The diagram shows a quadrilateral $ABCD$ in which A is $(6, 0)$, C is $(3k, 5k + 10)$ and D is $(-2, 4)$. The equation of line AB is $y = 2x - 12$ and angle $ADC = 90^\circ$.

(i) Find the value of k .

[3]

Solution

$$\text{Gradient of line } AD = \frac{4-0}{-2-6} = -\frac{1}{2}$$

$$\text{Gradient of line } CD = 2$$

$$\frac{5k+10-4}{3k+2} = 2$$

$$5k+6 = 6k+4$$

$$k = 2$$

Given that the perpendicular bisector of CD passes through B , find

[Turn over

(ii) the coordinates of B ,

[4]

Solution

$$\text{Midpoint of line } CD = \left(\frac{6-2}{2}, \frac{24}{2}\right) = (2, 12)$$

$$\text{Gradient of perpendicular bisector of } CD = -\frac{1}{2}$$

Equation of perpendicular bisector of CD :

$$y - 12 = \frac{-1}{2}(x - 2)$$

$$y = -\frac{1}{2}x + 13$$

To find intersection point between equation of line AB with perpendicular bisector of CD : solve simultaneously

$$y = -\frac{1}{2}x + 13$$

$$y = 2x - 12$$

$$-\frac{1}{2}x + 13 = 2x - 12$$

$$2.5x = 25$$

$$x = 10,$$

$$y = 8$$

$$B = (10, 8)$$

(iii) the area of the quadrilateral $ABCD$.

[2]

Solution

Area of $ABCD$

$$= \frac{1}{2} \begin{vmatrix} 6 & 10 & 6 & -2 & 6 \\ 0 & 8 & 20 & 4 & 0 \end{vmatrix}$$

$$= \frac{1}{2} |48 + 200 + 24 - (48 - 40 + 24)|$$

$$= 120 \text{ units}^2$$

- 9 (a) The first three terms in the binomial expansion of $(1 + px)^n$ are $1 - 48x + 960x^2$.
Find the value of p and of n . [4]

Solution

$$(1 + px)^n = \binom{n}{0} (px)^0 + \binom{n}{1} (px)^1 + \binom{n}{2} (px)^2 + \dots$$

$$= 1 + np x + \frac{n(n-1)}{2} p^2 x^2 + \dots$$

Comparing coefficients of

$$x \text{ ----- } np = -48$$

$$x^2 \text{ ----- } \frac{n(n-1)}{2} p^2 = 960$$

Solving by substitution: $p = \frac{-48}{n}$

$$\frac{n(n-1)}{2} \left(\frac{-48}{n}\right)^2 = 960$$

$$\frac{n-1}{n} = \frac{5}{6}$$

$$6n - 6 = 5n$$

$$n = 6$$

$$p = \frac{-48}{6} = -8$$

- (b) In the expansion of $\left(2x^2 + \frac{a}{x}\right)^8$, where a is a non-zero real number, the ratio of the coefficient of the 3rd term to that of the 5th term is 5 : 2.

- (i) Find the possible values of a . [4]

Solution

$$\text{General Term, } T_{r+1} = \binom{8}{r} (2x^2)^{8-r} \left(\frac{a}{x}\right)^r$$

$$T_3 = \binom{8}{2} (2x^2)^6 \left(\frac{a}{x}\right)^2 = \binom{8}{2} (2)^6 (a)^2 (x)^{10}$$

$$T_5 = \binom{8}{4} (2x^2)^4 \left(\frac{a}{x}\right)^4 = \binom{8}{4} (2)^4 (a)^4 (x)^4$$

$$\frac{28(64)a^2}{70(16)a^4} = \frac{5}{2}$$

$$3584a^2 = 5600a^4$$

$$5600a^4 - 3584a^2 = 0$$

$$a^2(5600a^2 - 3584) = 0$$

$$a = 0 \text{ (Rejected) or } a^2 = \frac{3584}{5600} \implies a = \pm \frac{4}{5}$$

(ii) **Explain** whether the term independent of x exists for the expansion of $\left(2x^2 + \frac{a}{x}\right)^8$. [2]

Solution

For term independent of x , power of $x = 0$

Considering the terms in x of the general term,

$$(x^2)^{8-r} (x)^{-r} = x^{16-3r}$$

Supposing $16 - 3r = 0$, $r = \frac{16}{3}$ (not a positive integer/whole number)

Term independent of x does not exist.

10

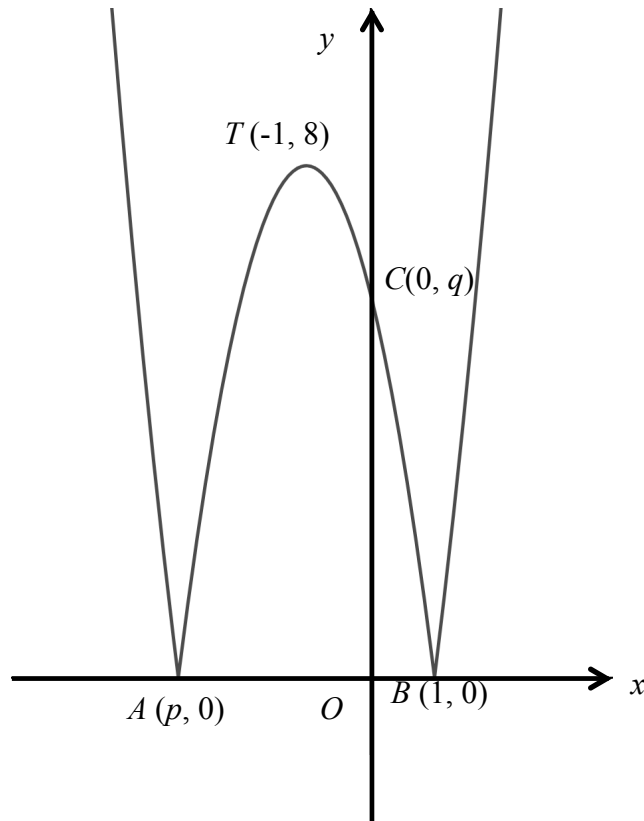

The diagram shows part of the curve $y = |ax^2 + bx + c|$ where $a < 0$.

The curve touches the x -axis at $A(p, 0)$ and at $B(1, 0)$.

The curve touches the y -axis at $C(0, q)$ and has a maximum point at $T(-1, 8)$.

(i) **Explain** why $p = -3$.

[1]

Solution

The curve is symmetrical about the line $x = -1$.

$$x\text{-coord of } A = p = -1 - 2 = -3$$

(ii) Determine the value of each of a , b , c and q .

[4]

Solution

$$y = |m(x + 3)(x - 1)|$$

$$\text{At } x = -1, y = 8$$

$$8 = |m(2)(-2)|$$

$$m = 2 \text{ or } -2$$

For $y = |ax^2 + bx + c|$ where $a < 0$, $a = -2$

$$y = |-2x^2 + bx + c|$$

$$-2x^2 + bx + c$$

$$= -2(x - 1)(x + 3)$$

$$= -2(x^2 + 2x - 3)$$

$$b = -4, c = 6$$

At $x = 0, y = 6$. Therefore $q = 6$.

(iii) State the set of values of r for which the line $y = r$ intersects the curve

$y = |ax^2 + bx + c|$ at four distinct points.

[1]

Solution

$$0 < r < 8$$

(iv) In the case where $r = 2$, find the exact x -coordinates of all points of intersection of the

line $y = r$ and the curve $y = |ax^2 + bx + c|$.

[4]

Solution

$$\text{Line: } y = 2$$

$$\text{Curve: } y = |-2x^2 - 4x + 6|$$

$$-2x^2 - 4x + 6 = 2$$

$$-2x^2 - 4x + 6 = -2$$

$$2x^2 + 4x - 4 = 0$$

$$\text{or } 2x^2 + 4x - 8 = 0$$

$$x^2 + 2x - 2 = 0$$

$$x^2 + 2x - 4 = 0$$

$$x = \frac{-2 \pm \sqrt{2^2 - 4(1)(-2)}}{2(1)} \quad \text{or } x = \frac{-2 \pm \sqrt{2^2 - 4(1)(-4)}}{2(1)}$$

$$x = \frac{-2 \pm \sqrt{12}}{2}$$

$$\text{or } x = \frac{-2 \pm \sqrt{20}}{2}$$

$$x = -1 \pm \sqrt{3}$$

$$x = -1 \pm \sqrt{5}$$

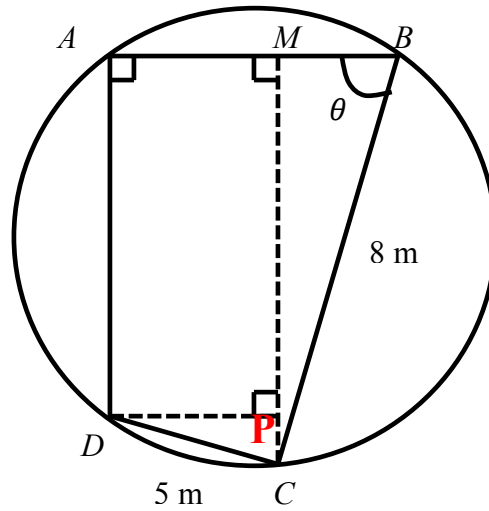

The diagram shows a circular garden. A farmer decides to fence part of the garden. He puts fences around the perimeter $ABCD$ such that $BC = 8$ m, $CD = 5$ m, angle $DAB = 90^\circ$ and angle $ABC = \theta$ where $0^\circ < \theta < 90^\circ$.

(i) Given that CM is perpendicular to AB , express CM and AB in terms of θ .

[4]

Solution

$$\sin\theta = \frac{CM}{8}$$

$$CM = 8\sin\theta$$

$$\cos\theta = \frac{BM}{8}$$

$$BM = 8\cos\theta$$

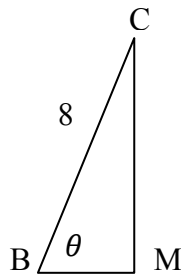

$$\sin\theta = \frac{DP}{5}$$

$$DP = 5\sin\theta$$

$$AB = 5\sin\theta + 8\cos\theta$$

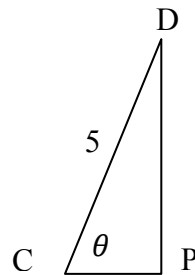

(ii) Show that L m, the length of fencing needed for perimeter $ABCD$, is given by

$$L = 13 + 3\cos\theta + 13\sin\theta.$$

[2]

Solution	
$\cos\theta = \frac{CP}{5}$ $CP = 5\cos\theta$ $MP = 8\sin\theta - 5\cos\theta = AD$	
Perimeter $ABCD$ $= 5\sin\theta + 8\cos\theta + 8 + 5 + 8\sin\theta - 5\cos\theta$ $= 13 + 3\cos\theta + 13\sin\theta$	

(iii) Express L in the form $13 + R\cos(\theta - \alpha)$ where $R > 0$ and α is an acute angle.

[4]

Solution	
$L = 13 + \sqrt{3^2 + 13^2}\cos(\theta - \alpha)$	$\tan\alpha = \frac{13}{3}$
$= 13 + \sqrt{178}\cos(\theta - 77.0^\circ)$	$\alpha = 77.0^\circ$

(iv) Given that the farmer uses exactly 26.2 m of fencing, find the possible values of θ . [3]

Solution
$13 + \sqrt{178}\cos(\theta - 77.0^\circ) = 26.2$
$\sqrt{178}\cos(\theta - 77.0^\circ) = 13.2$
$\cos(\theta - 77.0^\circ) = \frac{13.2}{\sqrt{178}}$
Basic Angle = 8.4°
$\theta - 77.0^\circ = 8.4^\circ, -8.4^\circ$
$\theta = 85.4^\circ, 68.6^\circ$

12 (a) It is given that $\int f(x)dx = k \cos 2x - \sin 3x + c$, where c is a constant of integration,

$$\text{and that } \int_0^{\frac{\pi}{6}} f(x) dx = \frac{1}{3}.$$

(i) Show that $k = -2\frac{2}{3}$.

[1]

Solution

$$[k \cos 2x - \sin 3x]_0^{\frac{\pi}{6}} = \frac{1}{3}$$

$$k \cos \frac{\pi}{3} - \sin \frac{\pi}{2} - (k \cos 0) = \frac{1}{3}$$

$$\frac{k}{2} - 1 - k = \frac{1}{3}$$

$$-\frac{k}{2} = \frac{4}{3}$$

$$k = -\frac{8}{3} = -2\frac{2}{3}$$

(ii) Find $f(x)$.

[2]

Solution

$$f(x) = \frac{d}{dx} \left(-2\frac{2}{3} \cos 2x - \sin 3x \right)$$

$$= -2\frac{2}{3} (-2 \sin 2x) - 3 \cos 3x$$

$$= \frac{16}{3} \sin 2x - 3 \cos 3x$$

(b) A curve has the equation $y = g(x)$, where $g(x) = 2\sin^2 x - \sin 2x$ for $0 \leq x \leq \pi$.

(i) Find the x -coordinates of the stationary points of the curve.

[3]

Solutions

$$y = 2\sin^2 x - \sin 2x$$

$$\frac{dy}{dx} = 4\sin x \cos x - 2\cos 2x = 0$$

$$2\sin 2x - 2\cos 2x = 0$$

$$\sin 2x = \cos 2x$$

$$\tan 2x = 1$$

$$\text{Basic Angle} = \frac{\pi}{4}$$

$$2x = \frac{\pi}{4}, \frac{5\pi}{4}$$

$$x = \frac{\pi}{8}, \frac{5\pi}{8}$$

(ii) Use the second derivative test to determine the nature of each of these points. [3]

Solution

$$\frac{d^2y}{dx^2} = 4\cos 2x - 2(-2\sin 2x)$$

$$= 4\cos 2x + 4\sin 2x$$

$$\text{At } x = \frac{\pi}{8},$$

$$\frac{d^2y}{dx^2} = 4\cos \frac{\pi}{4} + 4\sin \frac{\pi}{4} > 0$$

$$\text{Minimum point at } x = \frac{\pi}{8}.$$

$$\text{At } x = \frac{5\pi}{8},$$

$$\frac{d^2y}{dx^2} = 4\cos \frac{10\pi}{8} + 4\sin \frac{10\pi}{8} < 0$$

$$\text{Maximum point at } x = \frac{5\pi}{8}.$$

(iii) Given that $\int g(x)dx = ax + b\sin x \cos x + \cos^2 x + k$, where k is a constant of integration, find the value of a and of b .

[4]

Solutions

$$\begin{aligned} & \int 2\sin^2 x - \sin 2x \, dx \\ &= \int 1 - \cos 2x - \sin 2x \, dx \\ &= x - \frac{\sin 2x}{2} + \frac{\cos 2x}{2} + C \\ &= x - \frac{2\sin x \cos x}{2} + \frac{2\cos^2 x - 1}{2} + C \\ &= x - \sin x \cos x + \cos^2 x - \frac{1}{2} + C \\ &a = 1, b = -1 \end{aligned}$$

END OF PAPER

[Turn over