

Visit

FREETESTPAPER.com

for more papers



Website: [freetestpaper.com](http://www.freetestpaper.com)



[Facebook.com/freetestpaper](https://www.facebook.com/freetestpaper)



[Twitter.com/freetestpaper](https://www.twitter.com/freetestpaper)

Name : _____

Class Index Number

--	--

METHODIST GIRLS' SCHOOL

Founded in 1887



PRELIMINARY EXAMINATION 2021 Secondary 4

Friday

ADDITIONAL MATHEMATICS

4049/01

13 August 2021

Paper 1

2 h 15 min

Candidates answer on the Question Paper.
No Additional Materials are required.

READ THESE INSTRUCTIONS FIRST

Write your class, index number and name in the spaces at the top of this page.

Write in dark blue or black pen

You may use a HB pencil for any diagrams or graphs.

Do not use staples, paper clips, glue or correction fluid.

Answer **all** questions.

Give non-exact numerical answers correct to 3 significant figure, or 1 decimal place in the case of angles in degrees, unless a different level of accuracy is specified in the question.

The use of an approved scientific calculator is expected, where appropriate.

You are reminded of the need for clear presentation in your answers.

The number of marks is given in brackets [] at the end of each question or part question.

The total number of marks for this paper is 90.

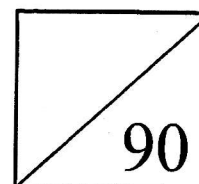

*Mathematical Formulae***1. ALGEBRA****Quadratic Equation**For the quadratic equation $ax^2 + bx + c = 0$,

$$x = \frac{-b \pm \sqrt{b^2 - 4ac}}{2a}$$

Binomial Expansion

$$(a + b)^n = a^n + \binom{n}{1}a^{n-1}b + \binom{n}{2}a^{n-2}b^2 + \dots + \binom{n}{r}a^{n-r}b^r + \dots + b^n,$$

where n is a positive integer and $\binom{n}{r} = \frac{n!}{r!(n-r)!} = \frac{n(n-1)\dots(n-r+1)}{r!}$.**2. TRIGONOMETRY***Identities*

$$\sin^2 A + \cos^2 A = 1$$

$$\sec^2 A = 1 + \tan^2 A$$

$$\operatorname{cosec}^2 A = 1 + \cot^2 A$$

$$\sin(A \pm B) = \sin A \cos B \pm \cos A \sin B$$

$$\cos(A \pm B) = \cos A \cos B \mp \sin A \sin B$$

$$\tan(A \pm B) = \frac{\tan A \pm \tan B}{1 \mp \tan A \tan B}$$

$$\sin 2A = 2 \sin A \cos A$$

$$\cos 2A = \cos^2 A - \sin^2 A = 2 \cos^2 A - 1 = 1 - 2 \sin^2 A$$

$$\tan 2A = \frac{2 \tan A}{1 - \tan^2 A}$$

Formulae for $\triangle ABC$

$$\frac{a}{\sin A} = \frac{b}{\sin B} = \frac{c}{\sin C}$$

$$a^2 = b^2 + c^2 - 2bc \cos A$$

$$\Delta = \frac{1}{2} bc \sin A$$

- 1 The diagram shows the graphs of $y = 2x - 1$ and $y = kx^2$, where k is a positive constant. The graphs intersect at two distinct points A and B .

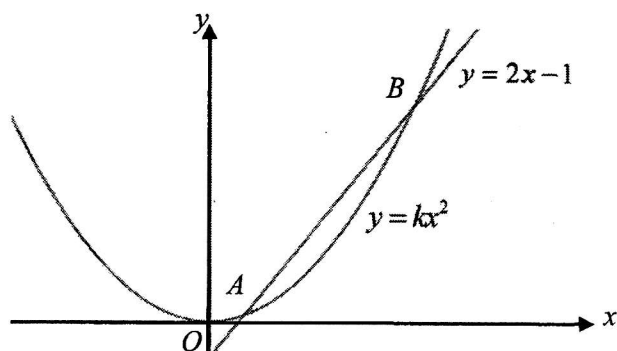

- (i) Show that $k < 1$. [2]
- (ii) Describe the relationship between the graphs $y = 2x - 1$ and $y = kx^2$ for $k = 1$ [2]

- 2 It is given that $f(x)$ is such that $f'(x) = 3 \sin x \cos x$ and $\left(\frac{\pi}{2}, 1\right)$ is a point on $f(x)$. Find an expression for $f(x)$. [5]

3 (a) Factorise $3x^3 - 24y^3$ completely. [2]

(b) Express $\frac{7x^2 + 19x + 15}{(x+1)^2(x+2)}$ as partial fractions. [5]

4 (i) Show that $\frac{d}{dx}(2x \ln x) = 2 \ln x + 2$. [2]

(ii) A curve is such that the gradient of its tangent is $\ln x$ and it passes through the point $(e^2, 4)$. Using part (i), find the equation of the curve, leaving your answer in exact form. [4]

- 5 Given that $\sin A = -\frac{4}{5}$, $\tan B = -\frac{5}{12}$ and $\cos A > 0$, where A and B are in different quadrants, evaluate without using calculators, the values of

(i) $\cot A$, [1]

(ii) $\cos (A + B)$, [2]

(iii) $\sin\left(\frac{B}{2}\right)$. [3]

6 (a) Find the range of values of x for which $(3x-2)(x+2) > 3x-2$. [3]

(b) The path of a diver, John, is modelled by the function $y = -3x^2 + 4.5x + 10$, where y is the height, in metres, of John above the water and x is the horizontal distance, in metres, of John from the end of the diving board.

(i) Find the height of John above the water when he first left the diving board. [1]

(ii) John said that he could reach a height of 12m above the water when executing his dive. Do you agree? Explain your answer. [3]

- 7 (a) Explain why all terms in the expansion of $(kx^3 + x)^{12}$ do not contain any odd powers of x . [3]

- (b) Given that the coefficient of x^{16} in the expansion of $\left(1 - \frac{x}{2}\right)^2 (kx^3 + x)^{12}$ is 258, find the integral value of k . [5]

- 8 The diagram shows part of the curve $y = \frac{4x+1}{x-2}$.
A line intersects the curve at points $P(11,5)$ and $Q(3,13)$.

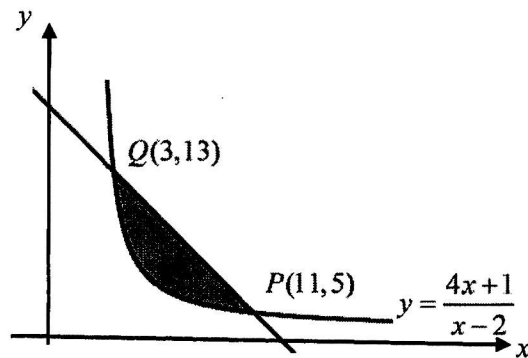

By expressing $\frac{4x+1}{x-2}$ in the form $a + \frac{b}{x-2}$, where a and b are constants, find, showing full working, the area of the shaded region. [7]

9 The equation of a polynomial is given by $p(x) = 4x^3 + x - 5$.
(i) Find the remainder when $p(x)$ is divided by $(2x - 1)$. [1]

(ii) Show that the equation $p(x) = 0$ has only one real root. [4]

(iii) Hence, solve the equation $2^{3y+2} + 2^y - 5 = 0$. [2]

- 10 The figure shows two circles C_1 and C_2 which touch each other and lie in the xy -plane as shown below. C_1 has radius 4 units and touches the x -axis at D , C_2 has radius 3 units and touches the y -axis at E . The line AB , joining the centres of C_2 and C_1 , meets the x -axis at F such that $\angle BFO = \theta^\circ$.

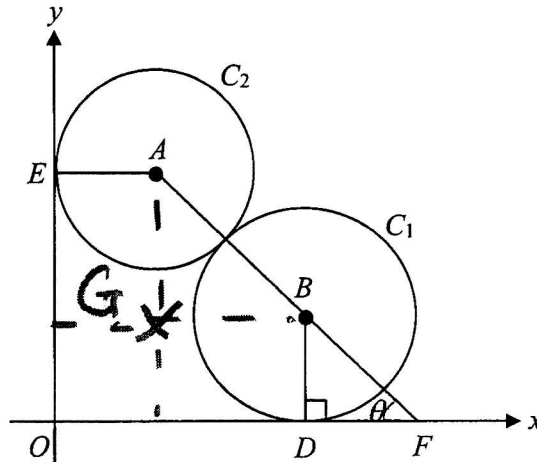

- (i) Obtain expressions for OD and OE in terms of θ and show that $ED^2 = 74 + 56\sin\theta + 42\cos\theta$.

[3]

(ii) Express ED^2 in the form $74 + R \cos(\theta - \alpha)$ where $R > 0$ and $0^\circ < \alpha < 90^\circ$. [3]

(iii) Find the maximum value of ED and the value of θ at which this occurs. [2]

- 11 The diagram shows a cat scratch stand which consists of a solid cylinder fixed to a solid cuboid. The cylinder has a radius of x cm and a height of y cm. The cuboid has a square base of side $3x$ cm and a height of x cm.

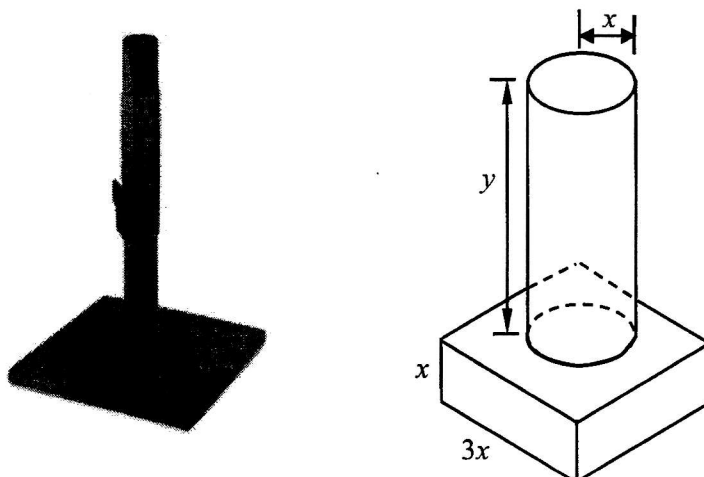

- (i) Given that the total volume of the wood material needed to make the scratch stand is 1300 cm^3 , express y in terms of x . [2]

- (ii) Show that the total surface area, $A \text{ cm}^2$, of the scratch stand is given by $A = \frac{2600}{x} + 12x^2$. [2]

Given that x can vary,

(iii) find the stationary value of A ,

[3]

(iv) determine whether this stationary value of A is a maximum or a minimum.

[2]

12 A curve has the equation $y = \frac{2 \sin 3x}{2 \cos 3x + 5}$.

(i) Find the value of a and of b for which $\frac{dy}{dx} = \frac{a + b \cos 3x}{(2 \cos 3x + 5)^2}$. [3]

- (ii) Hence, find the x -coordinates, where $0 \leq x \leq \pi$, of the points at which the normal to the curve is parallel to the y -axis. [5]

- 13 In the figure, BC is a diameter of the circle with O as the centre. H is the midpoint of CF . ABC is a straight line and AG is a tangent to the circle at point F . The line EF intersects OH at point X and E is the midpoint of CO .

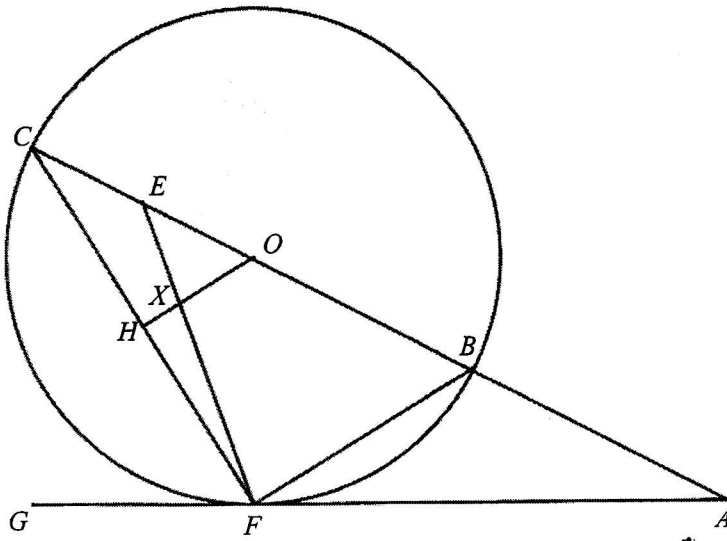

- (i) Prove that triangles ABF and AFC are similar. [2]

- (ii) Show that $AF^2 = AB^2 + AB \times BC$. [2]

(iii) Prove that $OX : XH = 2 : 1$.

[4]

End of Paper.

Page 20 of 20

Blank Page

Name : _____

ANS

Class Index Number

--	--

METHODIST GIRLS' SCHOOL

Founded in 1887



PRELIMINARY EXAMINATION 2021 Secondary 4

Friday

ADDITIONAL MATHEMATICS

4049/01

13 August 2021

Paper 1

2 h 15 min

Candidates answer on the Question Paper.
No Additional Materials are required.

READ THESE INSTRUCTIONS FIRST

Write your class, index number and name in the spaces at the top of this page.

Write in dark blue or black pen

You may use a HB pencil for any diagrams or graphs.

Do not use staples, paper clips, glue or correction fluid.

Answer **all** questions.

Give non-exact numerical answers correct to 3 significant figure, or 1 decimal place in the case of angles in degrees, unless a different level of accuracy is specified in the question.

The use of an approved scientific calculator is expected, where appropriate.

You are reminded of the need for clear presentation in your answers.

The number of marks is given in brackets [] at the end of each question or part question.

The total number of marks for this paper is 90.

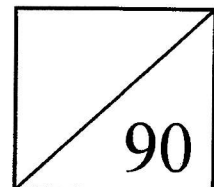

*Mathematical Formulae***1. ALGEBRA****Quadratic Equation**For the quadratic equation $ax^2 + bx + c = 0$,

$$x = \frac{-b \pm \sqrt{b^2 - 4ac}}{2a}$$

Binomial Expansion

$$(a + b)^n = a^n + \binom{n}{1} a^{n-1} b + \binom{n}{2} a^{n-2} b^2 + \dots + \binom{n}{r} a^{n-r} b^r + \dots + b^n,$$

where n is a positive integer and $\binom{n}{r} = \frac{n!}{r!(n-r)!} = \frac{n(n-1)\dots(n-r+1)}{r!}$.**2. TRIGONOMETRY***Identities*

$$\sin^2 A + \cos^2 A = 1$$

$$\sec^2 A = 1 + \tan^2 A$$

$$\operatorname{cosec}^2 A = 1 + \cot^2 A$$

$$\sin(A \pm B) = \sin A \cos B \pm \cos A \sin B$$

$$\cos(A \pm B) = \cos A \cos B \mp \sin A \sin B$$

$$\tan(A \pm B) = \frac{\tan A \pm \tan B}{1 \mp \tan A \tan B}$$

$$\sin 2A = 2 \sin A \cos A$$

$$\cos 2A = \cos^2 A - \sin^2 A = 2 \cos^2 A - 1 = 1 - 2 \sin^2 A$$

$$\tan 2A = \frac{2 \tan A}{1 - \tan^2 A}$$

Formulae for ΔABC

$$\frac{a}{\sin A} = \frac{b}{\sin B} = \frac{c}{\sin C}$$

$$a^2 = b^2 + c^2 - 2bc \cos A$$

$$\Delta = \frac{1}{2} bc \sin A$$

- 1 The diagram shows the graphs of $y = 2x - 1$ and $y = kx^2$, where k is a positive constant. The graphs intersect at two distinct points A and B .

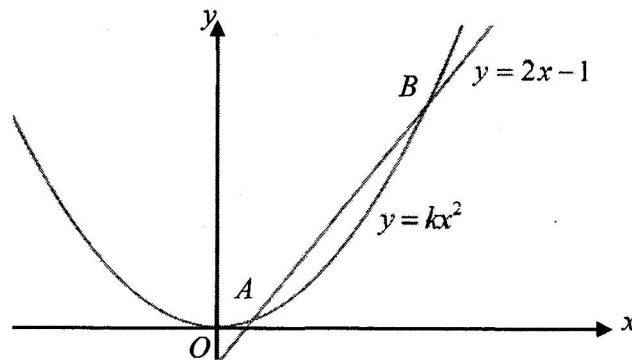

- (i) Show that $k < 1$. [2]

$$kx^2 = 2x - 1$$

$$kx^2 - 2x + 1 = 0$$

Discriminant > 0

$$(-2)^2 - 4(k)(1) > 0$$

$$4 - 4k > 0$$

$$k < 1$$

- (ii) Describe the relationship between the graphs $y = 2x - 1$ and $y = kx^2$ for $k = 1$ [2]

[Method 1]

When $k = 1$, **discriminant = 0**

The line $y = 2x - 1$ is a tangent to the curve $y = kx^2$ or

The line $y = 2x - 1$ touches the curve $y = kx^2$

[Method 2]

$$\text{When } k = 1, \quad x^2 - 2x + 1 = 0$$

$$x = 1, y = 1$$

The line $y = 2x - 1$ is a tangent to the curve $y = kx^2$ at $(1, 1)$ or

The line $y = 2x - 1$ touches the curve $y = kx^2$ at $(1, 1)$

- 2 It is given that $f(x)$ is such that $f'(x) = 3 \sin x \cos x$ and $\left(\frac{\pi}{2}, 1\right)$ is a point on $f(x)$. Find an expression for $f(x)$. [5]

$$f'(x) = 3 \sin x \cos x$$

$$f(x) = \int (3 \sin x \cos x) dx$$

$$= \int \frac{3}{2} (2 \sin x \cos x) dx$$

$$= \int \frac{3}{2} \sin 2x dx$$

$$f(x) = \frac{3}{2} \left(-\frac{\cos 2x}{2}\right) + c$$

$$\text{At } \left(\frac{\pi}{2}, 1\right),$$

$$1 = -\frac{3}{4} (-\cos \pi) + c$$

$$c = \frac{1}{4}$$

$$f(x) = -\frac{3}{4} \cos 2x + \frac{1}{4}$$

- 3 (a) Factorise $3x^3 - 24y^3$ completely. [2]

$$\begin{aligned} 3x^3 - 24y^3 &= 3(x^3 - 8y^3) \\ &= 3[(x)^3 - (2y)^3] \\ &= 3(x - 2y)(x^2 + 2xy + 4y^2) \end{aligned}$$

- (b) Express $\frac{7x^2 + 19x + 15}{(x+1)^2(x+2)}$ as partial fractions. [5]

$$\text{Let } \frac{7x^2 + 19x + 15}{(x+1)^2(x+2)} = \frac{A}{x+1} + \frac{B}{(x+1)^2} + \frac{C}{x+2} \quad [\text{M1}]$$

$$7x^2 + 19x + 15 = A(x+1)(x+2) + B(x+2) + C(x+1)^2$$

$$\text{Let } x = -1$$

$$7 - 19 + 15 = B$$

$$B = 3$$

$$\text{Let } x = -2,$$

$$28 - 38 + 15 = C$$

$$C = 5$$

$$\text{let } x = 0,$$

$$15 = A(1)(2) + 3(2) + 5(1)^2$$

$$2A = 4$$

$$A = 2$$

$$\frac{7x^2 + 19x + 15}{(x+1)^2(x+2)} = \frac{2}{x+1} + \frac{3}{(x+1)^2} + \frac{5}{x+2}$$

- 4 (i) Show that $\frac{d}{dx}(2x \ln x) = 2 \ln x + 2$. [2]

$$\begin{aligned}\frac{d}{dx}(2x \ln x) &= 2x \left(\frac{1}{x}\right) + (\ln x)(2) \\ &= 2 \ln x + 2\end{aligned}$$

- (ii) A curve is such that the gradient of its tangent is $\ln x$ and it passes through the point $(e^2, 4)$. Using part (i), find the equation of the curve, leaving your answer in exact form. [4]

$$\frac{dy}{dx} = \ln x$$

$$\frac{d}{dx}(2x \ln x) = 2 \ln x + 2$$

$$\frac{d}{dx}(x \ln x) = \ln x + 1$$

$$\int (1 + \ln x) dx = x \ln x + c, \text{ where } c \text{ is an arbitrary constant.}$$

$$\int \ln x dx = x \ln x - x + d, \text{ where } d \text{ is an arbitrary constant.}$$

$$\text{Equation of curve: } y = x \ln x - x + d$$

$$\text{At } (e^2, 4),$$

$$4 = e^2 \ln e^2 - e^2 + d$$

$$d = 4 - e^2$$

$$y = x \ln x - x + 4 - e^2$$

- 5 Given that $\sin A = -\frac{4}{5}$, $\tan B = -\frac{5}{12}$ and $\cos A > 0$, where A and B are in different quadrants, evaluate without using calculators, the values of

(i) $\cot A$, [1]

A is in the 4th quadrant and B is in the 2nd quadrant

$$\tan A = -\frac{4}{3}$$

$$\cot A = -\frac{3}{4}$$

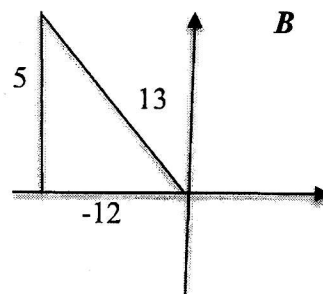
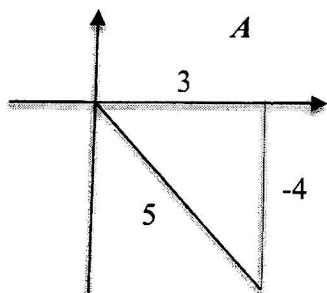

(ii) $\cos(A + B)$, [2]

$$\cos(A + B) = \cos A \cos B - \sin A \sin B$$

$$= \left(\frac{3}{5}\right)\left(\frac{-12}{13}\right) - \left(-\frac{4}{5}\right)\left(\frac{5}{13}\right)$$

$$= -\frac{16}{65}$$

(iii) $\sin\left(\frac{B}{2}\right)$. [3]

$$\cos B = 1 - 2\sin^2\left(\frac{B}{2}\right)$$

$$-\frac{12}{13} = 1 - 2\sin^2\left(\frac{B}{2}\right)$$

$$2\sin^2\left(\frac{B}{2}\right) = \frac{25}{13}$$

$$\sin^2\left(\frac{B}{2}\right) = \frac{25}{26}$$

$$\sin\left(\frac{B}{2}\right) = \sqrt{\frac{25}{26}} \quad (\text{rej negative value since } 0^\circ < \frac{B}{2} < 90^\circ)$$

$$= \frac{5}{\sqrt{26}}$$

$$= \frac{5\sqrt{26}}{26}$$

- 6 (a) Find the range of values of x for which $(3x-2)(x+2) > 3x-2$. [3]

$$\begin{aligned}(3x-2)(x+2) &> 3x-2 \\(3x-2)(x+2) - (3x-2) &> 0 \\(3x-2)(x+2-1) &> 0 \quad \text{or} \quad 3x^2 + x - 2 > 0 \\(3x-2)(x+1) &> 0 \\x < -1 \quad x > \frac{2}{3}\end{aligned}$$

- (b) The path of a diver, John, is modelled by the function $y = -3x^2 + 4.5x + 10$, where y is the height, in metres, of John above the water and x is the horizontal distance, in metres, of John from the end of the diving board.

- (i) Find the height of John above the water when he first left the diving board. [1]

When $x = 0$, $y = 10$
Height of John above the water = 10m

- (ii) John said that he could reach a height of 12m above the water when executing his dive. Do you agree? Explain your answer. [3]

Method 1:

$$y = -3 \left[x^2 - 1.5x + \left(\frac{3}{4}\right)^2 \right] + 10 + \frac{27}{16}$$

$$y = -3 \left[x - \frac{3}{4} \right]^2 + 11.6875$$

I do not agree as his max height above water is $11.6875 < 12$ m.

Method 2:

$$\begin{aligned}-3x^2 + 4.5x + 10 &= 12 \\-3x^2 + 4.5x - 2 &= 0\end{aligned}$$

$$\text{Discriminant} = (4.5)^2 - 4(-3)(-2) = -3.75 < 0$$

Since there are no **real** roots for x , I disagree with John as he will not reach 12.

Method 3: $y = -3x^2 + 4.5x + 10$

$$\frac{dy}{dx} = -6x + 4.5$$

For max or min y , $\frac{dy}{dx} = 0 \Rightarrow x = 0.75$

$$\frac{d^2y}{dx^2} = -6 < 0 \Rightarrow \text{max } y$$

When $x = 0.75$, $\text{max } y = 11.6875 < 12$, I disagree with John as he will not reach 12.

- 7 (a) Explain why all terms in the expansion of $(kx^3 + x)^{12}$ do not contain any odd powers of x . [3]

$$\begin{aligned} \text{General Term} &= \binom{12}{r} (kx^3)^{12-r} x^r \\ &= \binom{12}{r} k^{12-r} x^{36-3r+r} \\ &= \binom{12}{r} k^{12-r} x^{2(18-r)} \end{aligned}$$

Since the index of x is a multiple of 2, the expansion will not contain any odd powers of x .

- (b) Given that the coefficient of x^{16} in the expansion of $\left(1 - \frac{x}{2}\right)^2 (kx^3 + x)^{12}$ is 258, find the integral value of k . [5]

$$\left(1 - \frac{x}{2}\right)^2 (kx^3 + x)^{12} = \left(1 - x + \frac{x^2}{4}\right) (\dots + \dots x^{14} \dots + \dots x^{16} + \dots)$$

$$2(18-r) = 14$$

$$r = 11$$

$$T_{12} = \binom{12}{11} kx^{14}$$

$$= 12kx^{14}$$

$$2(18-r) = 16$$

$$r = 10$$

$$T_{11} = \binom{12}{10} kx^{16}$$

$$= 66kx^{16}$$

$$(12k)\left(\frac{1}{4}\right) + 66k^2 = 258$$

$$66k^2 + 3k - 258 = 0$$

$$22k^2 + k - 86 = 0$$

$$(22k - 43)(k + 2) = 0$$

$$k = \frac{43}{22} \text{ (rej)} \quad k = -2$$

- 8 The diagram shows part of the curve $y = \frac{4x+1}{x-2}$.
A line intersects the curve at points $P(11,5)$ and $Q(3,13)$.

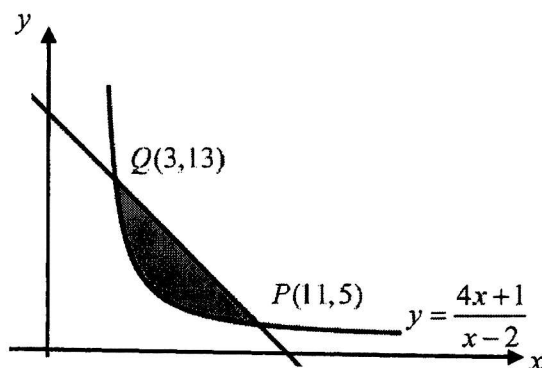

By expressing $\frac{4x+1}{x-2}$ in the form $a + \frac{b}{x-2}$, where a and b are constants, find, showing full working, the area of the shaded region. [7]

$$\frac{4x+1}{x-2} = 4 + \frac{9}{x-2}$$

$$\begin{array}{r} 4 \\ x-2 \overline{) 4x+1} \\ \underline{4x-8} \\ 9 \end{array} \quad [M1]$$

$$\text{Area} = \frac{1}{2}(13+5)(8) - \int_3^{11} \frac{4x+1}{x-2} dx \quad [M1]$$

$$= 4(18) - \int_3^{11} \left[4 + \frac{9}{x-2} \right] dx$$

$$= 72 - \left\{ [4x]_3^{11} + [9 \ln(x-2)]_3^{11} \right\}$$

$$= 72 - [(44-12) - (9 \ln 9 - 9 \ln 1)]$$

$$= 20.2 \text{ units}^2 \quad \text{or} \quad 40 - 9 \ln 9$$

9 The equation of a polynomial is given by $p(x) = 4x^3 + x - 5$.

(i) Find the remainder when $p(x)$ is divided by $(2x-1)$. [1]

$$p\left(\frac{1}{2}\right) = 4\left[\frac{1}{2}\right]^3 + \left(\frac{1}{2}\right) - 5 = -4 \quad \text{Remainder} = -4$$

(ii) Show that the equation $p(x) = 0$ has only one real root. [4]

By trial and error,

$$p(1) = 4(1)^3 + 1 - 5 = 0$$

$(x-1)$ is a factor.

$$p(x) = (x-1)(4x^2 + 4x + 5) \quad [\text{show long division}]$$

$$0 = (x-1)(4x^2 + 4x + 5)$$

$$0 = (x-1) \quad 0 = (4x^2 + 4x + 5)$$

$$x = 1 \quad \text{Discriminant} = 16 - 4(4)(5) \\ = -64 < 0$$

Therefore no real roots.

Hence, $p(x)$ has only 1 real root, $x = 1$.

(iii) Hence, solve the equation $2^{3y+2} + 2^y - 5 = 0$. [2]

$$2^{3y+2} + 2^y - 5 = 0$$

$$2^{3y} 2^2 + 2^y - 5 = 0$$

$$4(2^y)^3 + 2^y - 5 = 0$$

$$(2^y - 1)[4(2^y)^2 + 4(2^y) + 5] = 0$$

$$2^y = 1 \quad [4(2^y)^2 + 4(2^y) + 5] = 0 \quad (\text{rej})$$

$$y = 0$$

- 10 The figure shows two circles C_1 and C_2 which touch each other and lie in the xy -plane as shown below. C_1 has radius 4 units and touches the x -axis at D , C_2 has radius 3 units and touches the y -axis at E . The line AB , joining the centres of C_2 and C_1 , meets the x -axis at F such that $\angle BFO = \theta^\circ$.

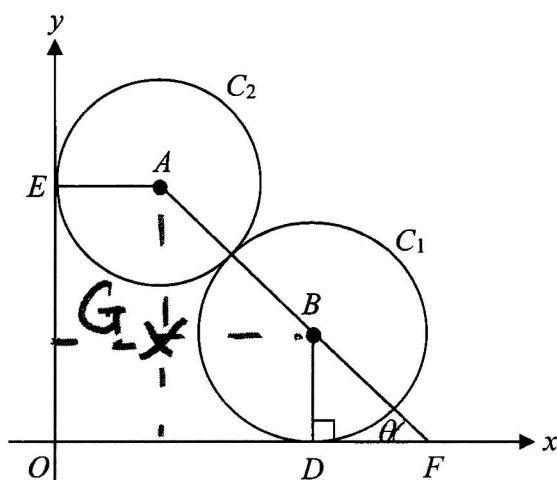

- (i) Obtain expressions for OD and OE in terms of θ and show that $ED^2 = 74 + 56 \sin \theta + 42 \cos \theta$.

[3]

$$ED^2 = EO^2 + OD^2$$

$$EO = AG + 4 = 7 \sin \theta + 4$$

$$OD = 3 + GB = 3 + 7 \cos \theta$$

$$ED^2 = [7 \sin \theta + 4]^2 + [3 + 7 \cos \theta]^2$$

$$= 49 \sin^2 \theta + 56 \sin \theta + 16 + 9 + 42 \cos \theta + 49 \cos^2 \theta$$

$$= 49 + 56 \sin \theta + 25 + 42 \cos \theta$$

$$= 74 + 56 \sin \theta + 42 \cos \theta$$

- (ii) Express ED^2 in the form $74 + R \cos(\theta - \alpha)$ where $R > 0$ and $0^\circ < \alpha < 90^\circ$. [3]

$$42 \cos \theta + 56 \sin \theta = R \cos \theta \cos \alpha + R \sin \theta \sin \alpha$$

$$R = \sqrt{56^2 + 42^2} = 70$$

$$\tan \alpha = \frac{56}{42}$$

$$\alpha = 53.1^\circ$$

$$ED^2 = 74 + 70 \cos(\theta - 53.1^\circ)$$

- (iii) Find the maximum value of ED and the value of θ at which this occurs. [2]

maximum ED when $\cos(\theta - 53.1^\circ) = 1$

$$\theta - 53.1^\circ = 0^\circ$$

$$\theta = 53.1^\circ$$

$$\text{Max } ED^2 = 74 + 70 = 144$$

$$\text{Max } ED = 12$$

- 11 The diagram shows a cat scratch stand which consists of a solid cylinder fixed to a solid cuboid. The cylinder has a radius of x cm and a height of y cm. The cuboid has a square base of side $3x$ cm and a height of x cm.

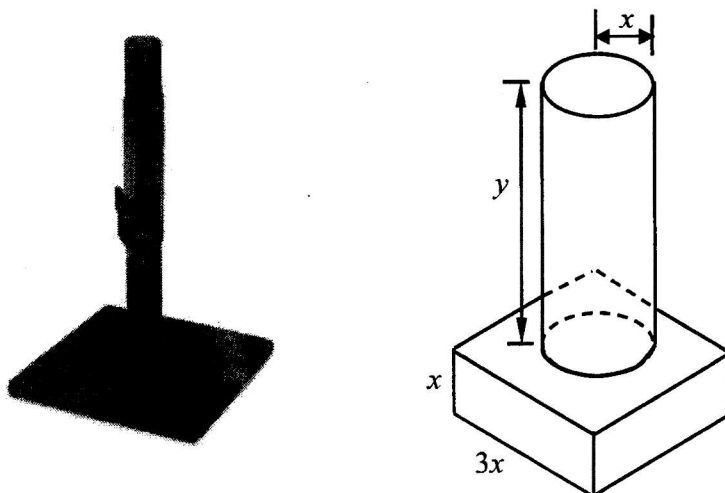

- (i) Given that the total volume of the wood material needed to make the scratch stand is 1300 cm^3 , express y in terms of x . [2]

$$1300 = (3x)^2(x) + \pi x^2 y$$

$$1300 = 9x^3 + \pi x^2 y$$

$$y = \frac{1300 - 9x^3}{\pi x^2}$$

- (ii) Show that the total surface area, $A \text{ cm}^2$, of the scratch stand is given by

$$A = \frac{2600}{x} + 12x^2. \quad [2]$$

$$A = x(3x)(4) + 2(3x)^2 + 2\pi(x)(y)$$

$$A = 12x^2 + 18x^2 + 2\pi(x)\left(\frac{1300 - 9x^3}{\pi x^2}\right)$$

$$A = 30x^2 + \frac{2600}{x} - 18x^2$$

$$A = \frac{2600}{x} + 12x^2$$

Given that x can vary,

(iii) find the stationary value of A ,

[3]

$$A = 2600x^{-1} + 12x^2$$

$$\frac{dA}{dx} = -2600x^{-2} + 24x$$

$$0 = -2600x^{-2} + 24x$$

$$2600 = 24x^3$$

$$x^3 = \frac{2600}{24}$$

$$x = 4.767098$$

Stationary Value of $A = 818 \text{ cm}^2$ (3sf)

(iv) determine whether this stationary value of A is a maximum or a minimum.

[2]

$$\frac{d^2A}{dx^2} = \frac{5200}{x^3} + 24$$

At $x = 4.767098$,

$$\frac{d^2A}{dx^2} = 72 > 0$$

$A = 818 \text{ cm}^2$ is a min value.

12 A curve has the equation $y = \frac{2 \sin 3x}{2 \cos 3x + 5}$.

(i) Find the value of a and of b for which $\frac{dy}{dx} = \frac{a + b \cos 3x}{(2 \cos 3x + 5)^2}$. [3]

$$\frac{dy}{dx} = \frac{(2 \cos 3x + 5)(6 \cos 3x) - (2 \sin 3x)(-6 \sin 3x)}{(2 \cos 3x + 5)^2}$$

$$\frac{dy}{dx} = \frac{12 \cos^2 3x + 30 \cos 3x + 12 \sin^2 3x}{(2 \cos 3x + 5)^2}$$

$$\frac{dy}{dx} = \frac{12 + 30 \cos 3x}{(2 \cos 3x + 5)^2}$$

$$a = 12 \quad b = 30$$

- (ii) Hence, find the x -coordinates, where $0 \leq x \leq \pi$, of the points at which the normal to the curve is parallel to the y -axis. [5]

Gradient of tangent = 0

$$\frac{dy}{dx} = 0$$

$$\frac{12 + 30 \cos 3x}{(2 \cos 3x + 5)^2} = 0$$

$$30 \cos 3x = -12$$

$$\cos 3x = -\frac{2}{5}$$

$$\alpha = 1.15927$$

$$3x = \pi - \alpha, \pi + \alpha, 3\pi - \alpha$$

$$= 1.98231, 4.30087, 8.2655$$

$$x = 0.661, 1.43, 2.76$$

- 13 In the figure, BC is a diameter of the circle with O as the centre. H is the midpoint of CF . ABC is a straight line and AG is a tangent to the circle at point F . The line EF intersects OH at point X and E is the midpoint of CO .

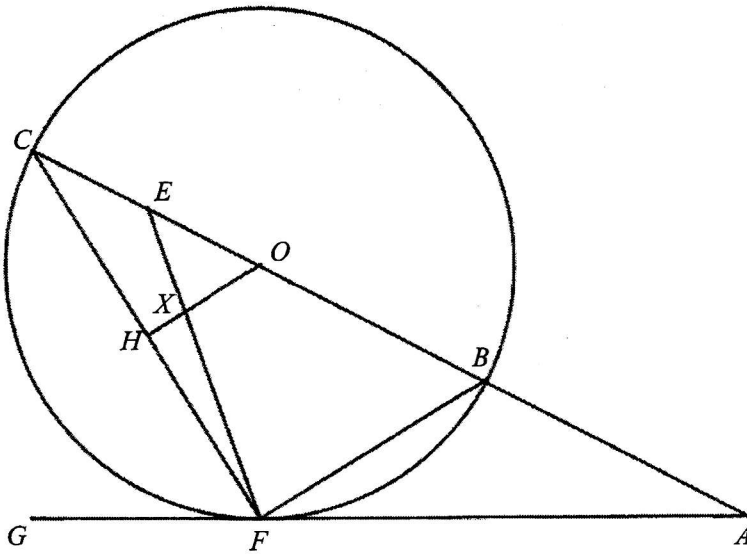

- (i) Prove that triangles ABF and AFC are similar. [2]

- (ii) Show that $AF^2 = AB^2 + AB \times BC$. [2]

(iii) Prove that $OX : XH = 2 : 1$.

[4]

End of Paper.

Name : _____

Class	Index Number

METHODIST GIRLS' SCHOOL

Founded in 1887



PRELIMINARY EXAMINATION 2021 Secondary 4

Wednesday

ADDITIONAL MATHEMATICS

4049/02

18 August 2021

Paper 2

2 h 15 min

Candidates answer on the Question Paper

No Additional Materials are required

READ THESE INSTRUCTIONS FIRST

Write your class, index number and name in the spaces at the top of this page.

Write in dark blue or black pen.

You may use a HB pencil for any diagrams or graphs.

Do not use staples, paper clips, glue or correction fluid.

Answer **all** the questions.

Give non-exact numerical answers correct to 3 significant figures, or 1 decimal place in the case of angles in degrees, unless a different level of accuracy is specified in the question.

The use of an approved scientific calculator is expected, where appropriate.

You are reminded of the need for clear presentation in your answers.

The number of marks is given in brackets [] at the end of each question or part question.

The total number of marks for this paper is **90**.

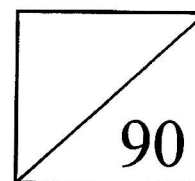

*Mathematical Formulae***1. ALGEBRA****Quadratic Equation**For the quadratic equation $ax^2 + bx + c = 0$,

$$x = \frac{-b \pm \sqrt{b^2 - 4ac}}{2a}$$

Binomial Expansion

$$(a+b)^n = a^n + \binom{n}{1}a^{n-1}b + \binom{n}{2}a^{n-2}b^2 + \dots + \binom{n}{r}a^{n-r}b^r + \dots + b^n,$$

where n is a positive integer and $\binom{n}{r} = \frac{n!}{r!(n-r)!} = \frac{n(n-1)\dots(n-r+1)}{r!}$.

2. TRIGONOMETRY*Identities*

$$\sin^2 A + \cos^2 A = 1$$

$$\sec^2 A = 1 + \tan^2 A$$

$$\operatorname{cosec}^2 A = 1 + \cot^2 A$$

$$\sin(A \pm B) = \sin A \cos B \pm \cos A \sin B$$

$$\cos(A \pm B) = \cos A \cos B \mp \sin A \sin B$$

$$\tan(A \pm B) = \frac{\tan A \pm \tan B}{1 \mp \tan A \tan B}$$

$$\sin 2A = 2 \sin A \cos A$$

$$\cos 2A = \cos^2 A - \sin^2 A = 2 \cos^2 A - 1 = 1 - 2 \sin^2 A$$

$$\tan 2A = \frac{2 \tan A}{1 - \tan^2 A}$$

Formulae for $\triangle ABC$

$$\frac{a}{\sin A} = \frac{b}{\sin B} = \frac{c}{\sin C}$$

$$a^2 = b^2 + c^2 - 2bc \cos A$$

$$\Delta = \frac{1}{2}bc \sin A$$

- 1 (a) Sketch the graph of $y = \log_2(3x+1)$ and label the point where $x = \frac{1}{3}$. Explain why $x > -\frac{1}{3}$. [3]

(b) Solve $\log_2(3x+1) + \frac{1}{2}\log_{\sqrt{2}}(3x-1) = 1$. [4]

2

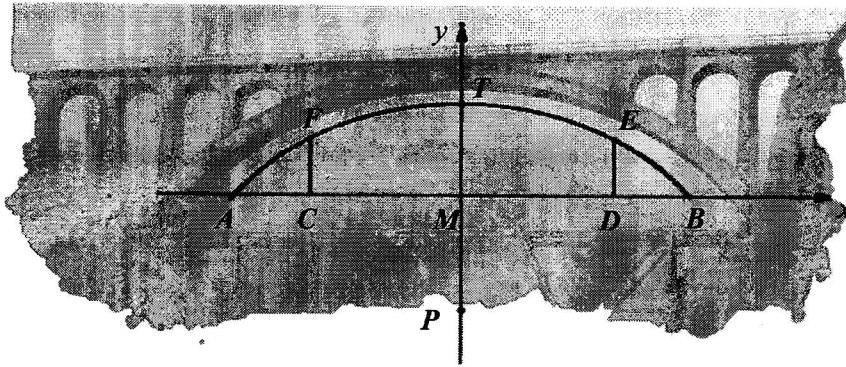

The diagram above shows an arch bridge. The arc $AFTEB$ is part of a circle with centre P , and AB is a chord 8 m. Point T is 1 m vertically above point M which is the midpoint of AB . CF and DE are perpendicular to chord AB . The arc $AFTEB$ can be modelled onto the coordinate plane below, where C and D are $(-3, 0)$ and $(3, 0)$ respectively.

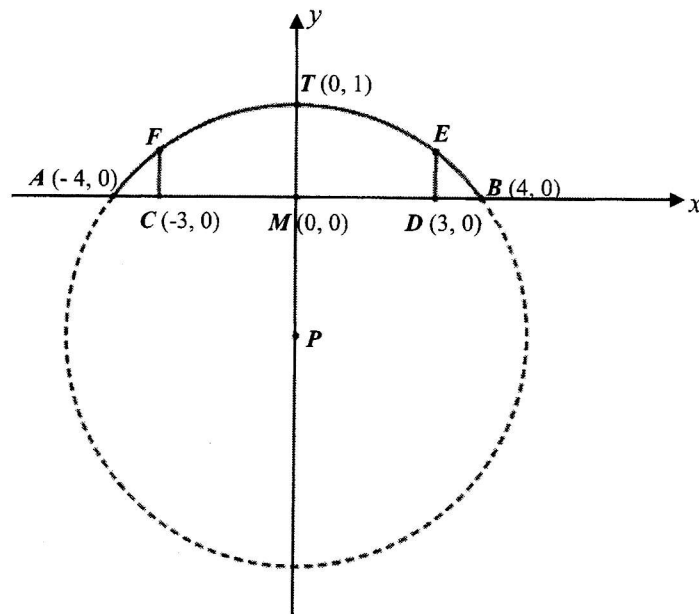

(i) Show that P is $(0, -7.5)$. [2]

2 (ii) Find the equation of the circle. [1]

(iii) Calculate the height of the pillar CF . [2]

(iv) Find the equation of tangent at point B .

[3]

3 (a) Solve $\sqrt{4x+12} - \sqrt{x+3} = 2$. [3]

(b) The volume of right circular cone is $4\pi \text{ cm}^3$. The radius of its base is $(1+\sqrt{2}) \text{ cm}$. Find, without the use of a calculator, the height of the cone in the form $(a+b\sqrt{2}) \text{ cm}$, where a and b are integers. [3]

- 4 A particle moving in a straight line, passes through a fixed point O with a velocity of 4 m/s . Its acceleration t seconds after passing through O , is $(6t - 8) \text{ m s}^{-2}$. Find
- (i) the minimum velocity of the particle, [4]
- (ii) the time when the particle first comes to an instantaneous rest, [2]
- (iii) the distance travelled in the 2nd second. [3]

5 (i) Prove that $\operatorname{cosec} 2x + \cot 2x = \cot x$. [3]

(ii) Hence, deduce the value of $\cot 15^\circ$ in surd form. [2]

(iii) Using part (i), solve $\operatorname{cosec} 2x + \cot 2x = 6 - 5 \tan x$ for $0^\circ \leq x \leq 360^\circ$ [4]

6 (a) It is given that $g(x) = 2e^x - 3\sqrt{e^x}$. Solve the equation $g(x) + 1 = 0$. [4]

(b) The function $f(x)$ is such that $f'(x) = 3e^x + e^{-2x}$.

(i) Given that $f(0) = 4$, find an expression for $f(x)$. [3]

(ii) Show that $\int_{-\ln 2}^0 f'(x) dx = k$, where k is a constant to be determined. [3]

- 7 (a) (i) An equation of a curve is $y = x^4 + 2x^3$. Find the coordinates of the stationary points and determine the nature of the stationary points. [5]

- (ii) Explain whether y is increasing or decreasing for $-1.5 < x < 0$. [2]

- 7 (b) Two variables x and y are related by the equation $8y = \left(\frac{x}{2} - 1\right)^4$. Given that both x and y vary with time, find the value of x at the instant when the rate of change of y is twice the rate of change of x . [3]

- 8 The population P , in millions, of a country was recorded on January of the various years and the results are shown in the table below.

Year	2005	2010	2015	2020
P	12.95	14.67	17.52	22.11

Given that $P = 10 + ab^t$, where t is the time measured in years from 2000 and a and b are constants.

$$\lg(P - 10) = \lg a + \lg b$$

- (i) Draw the graph of $\lg(P - 10)$ plotted against t , for $0 \leq t \leq 25$. [3]

- 8** **(ii)** Use the graph to estimate the values of a and b . **[4]**

- (iii)** Explain how the graph could be used to find the year in which the population

- 9 Solution to this question by accurate drawing will not be accepted.

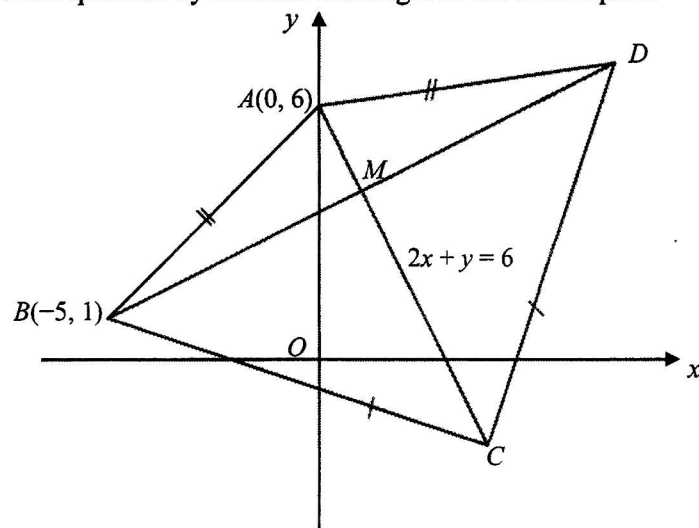

The diagram shows a kite $ABCD$ with $AB = AD$ and $CB = CD$. The diagonals intersect at M . It is given that the coordinates of A and B are $(0, 6)$ and $(-5, 1)$ respectively and the equation of AC is $2x + y = 6$.

Find

- (i) the equation of BD . [2]

- (ii) the coordinates of M and of D . [4]

- 9 Given further that the area of the triangle ABD is $\frac{1}{3}$ of the area of the triangle CBD ,
(iii) find the coordinates of C , [2]

- (iv) find the area of the kite $ABCD$. [2]

10 (i) Solve the equation $4 \cos 2A = 3 - 2 \sin A$ for $0 \leq A \leq 2\pi$. [4]

(ii) It is given that $f(x) = 2 \cos 6x - \frac{1}{2}$ and $g(x) = 1 - \sin 3x$. State the period of $f(x)$ and $g(x)$, in terms of π . [2]

10 (iii) Sketch, on the same axes, the graphs of for $y = f(x)$ and $y = g(x)$ for

$$0 \leq x \leq \frac{2\pi}{3}.$$

[4]

(iv) Explain how the solutions of the equations in part **(i)** could be used to find the x -coordinates of the points of intersection of the graphs of **(ii)**.

[2]

~ End of Paper ~

Page 20 of 22

Blank Page

Name : _____

ANS

Class Index Number

--	--

METHODIST GIRLS' SCHOOL

Founded in 1887



PRELIMINARY EXAMINATION 2021 Secondary 4

Wednesday

ADDITIONAL MATHEMATICS

4049/02

18 August 2021

Paper 2

2 h 15 min

Candidates answer on the Question Paper

No Additional Materials are required

READ THESE INSTRUCTIONS FIRST

Write your class, index number and name in the spaces at the top of this page.

Write in dark blue or black pen.

You may use a HB pencil for any diagrams or graphs.

Do not use staples, paper clips, glue or correction fluid.

Answer **all** the questions.

Give non-exact numerical answers correct to 3 significant figures, or 1 decimal place in the case of angles in degrees, unless a different level of accuracy is specified in the question.

The use of an approved scientific calculator is expected, where appropriate.

You are reminded of the need for clear presentation in your answers.

The number of marks is given in brackets [] at the end of each question or part question.

The total number of marks for this paper is **90**.

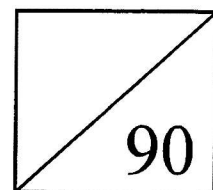

*Mathematical Formulae***1. ALGEBRA****Quadratic Equation**

For the quadratic equation $ax^2 + bx + c = 0$,

$$x = \frac{-b \pm \sqrt{b^2 - 4ac}}{2a}$$

Binomial Expansion

$$(a+b)^n = a^n + \binom{n}{1}a^{n-1}b + \binom{n}{2}a^{n-2}b^2 + \dots + \binom{n}{r}a^{n-r}b^r + \dots + b^n,$$

where n is a positive integer and $\binom{n}{r} = \frac{n!}{r!(n-r)!} = \frac{n(n-1)\dots(n-r+1)}{r!}$.

2. TRIGONOMETRY*Identities*

$$\sin^2 A + \cos^2 A = 1$$

$$\sec^2 A = 1 + \tan^2 A$$

$$\operatorname{cosec}^2 A = 1 + \cot^2 A$$

$$\sin(A \pm B) = \sin A \cos B \pm \cos A \sin B$$

$$\cos(A \pm B) = \cos A \cos B \mp \sin A \sin B$$

$$\tan(A \pm B) = \frac{\tan A \pm \tan B}{1 \mp \tan A \tan B}$$

$$\sin 2A = 2 \sin A \cos A$$

$$\cos 2A = \cos^2 A - \sin^2 A = 2 \cos^2 A - 1 = 1 - 2 \sin^2 A$$

$$\tan 2A = \frac{2 \tan A}{1 - \tan^2 A}$$

Formulae for $\triangle ABC$

$$\frac{a}{\sin A} = \frac{b}{\sin B} = \frac{c}{\sin C}$$

$$a^2 = b^2 + c^2 - 2bc \cos A$$

$$\Delta = \frac{1}{2}bc \sin A$$

- 1 (a) Sketch the graph of $y = \log_2(3x+1)$ and label the point where $x = \frac{1}{3}$. Explain

why $x > -\frac{1}{3}$.

[3]

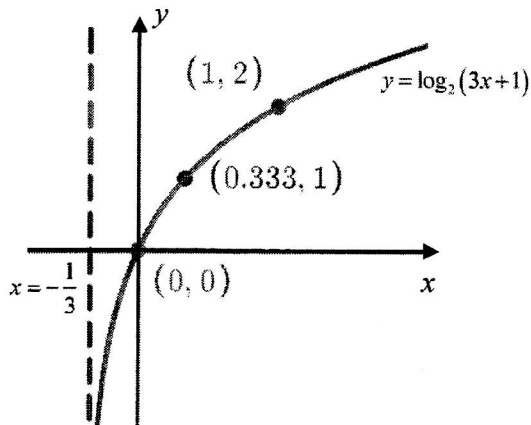

Asymptote – B1

Shape and point $(\frac{1}{3}, 1)$ -B1

$$y = \log_2(3x+1)$$

$$2^y = 3x+1$$

$$2^y > 0$$

$$3x+1 > 0$$

$$x > -\frac{1}{3}$$

A1

1. Some students do not know the shape of the curve.
2. Students do not know that the curve cuts through the origin or did not label the point $(\frac{1}{3}, 1)$ clearly.
3. Students did not put in the asymptote.
4. Students do not know how to explain why $x > -\frac{1}{3}$. By saying $x = -\frac{1}{3}$ is the asymptote is not enough. Cos the curve can be on the right or left of the asymptote. By using $x = -\frac{1}{3}$ and say this will result in $y=0$ also does not explain why x cannot be less than $\frac{1}{3}$.

(b) Solve $\log_2(3x+1) + \frac{1}{2}\log_{\sqrt{2}}(3x-1) = 1$. [4]

$$\log_2(3x+1) + \frac{1}{2}\log_{\sqrt{2}}(3x-1) = 1$$

$$\log_2(3x+1) + \frac{1}{2}\left(\frac{\log_2(3x-1)}{\log_2 2^{\frac{1}{2}}}\right) = 1 \quad \text{M1 - change base}$$

$$\log_2(3x+1) + \left(\frac{1}{2} \times 2\right)\log_2(3x-1) = 1$$

$$\log_2(3x+1)(3x-1) = 1$$

$$(3x+1)(3x-1) = 2 \quad \text{M1}$$

$$9x^2 - 1 = 2$$

$$x^2 = \frac{1}{3}$$

$$x = \sqrt{\frac{1}{3}} \quad \text{A1}$$

$$x = 0.192$$

$$x = -\sqrt{\frac{1}{3}} \quad \text{A1}$$

(rejected)

1. Students are confused with logarithmic rules. They wrote $\lg a + \lg b = \lg(a+b)$
2. Only a small handful is not able to change the base.
3. Students forgot to reject negative x value.
4. Students did not know as x^2 has positive and negative values.

2

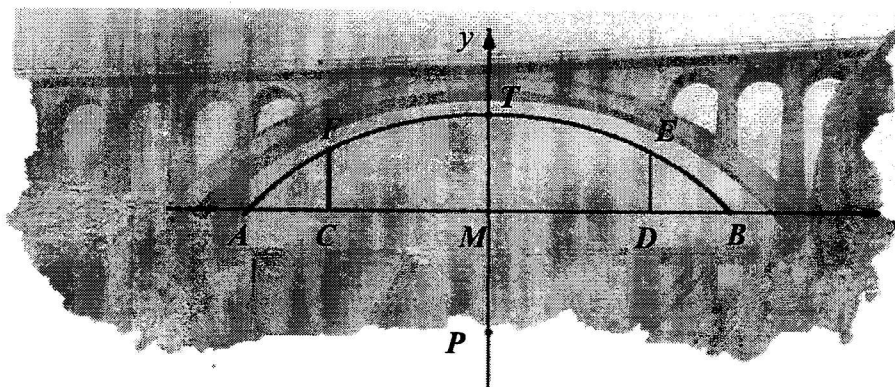

The diagram above shows an arch bridge. The arc $AFTEB$ is part of a circle with centre P , and AB is a chord 8 m. Point T is 1 m vertically above point M which is the midpoint of AB . CF and DE are perpendicular to chord AB . The arc $AFTEB$ can be modelled onto the coordinate plane below, where C and D are $(-3, 0)$ and $(3, 0)$ respectively.

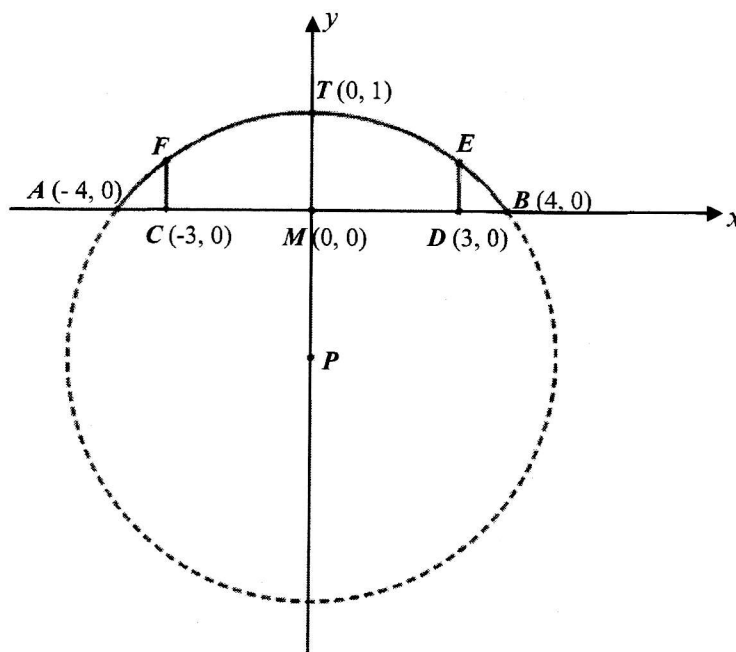

- (i) Show that P is $(0, -7.5)$. [2]

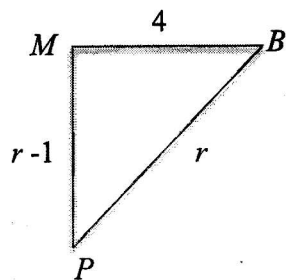

$$\begin{aligned} r^2 &= (r-1)^2 + 4^2 \\ r^2 &= r^2 - 2r + 1 + 16 && \text{M1} \\ 2r &= 17 \\ r &= 8.5 \\ & \text{A1} \end{aligned}$$

$$\therefore P(0, -7.5)$$

Alternative method:

Let Coordinate of P be (x, y)

x is on the y -axis, hence $x=0$

length of TP = length of BP

$$\sqrt{(1-y)^2} = \sqrt{(4-0)^2 + (0-y)^2}$$

$$1 - 2y + y^2 = 16 + y^2$$

$$-2y = 15$$

$$y = -7.5$$

$$P(0, -7.5)$$

Common errors:

Students randomly used radius as 15 cm to prove coordinates of P .

Students are careless in manipulation.

- 2 (ii) Find the equation of the circle. [1]

Centre $P(0, -7.5)$ and radius 8.5

Equation of circle is

$$x^2 + (y + 7.5)^2 = 8.5^2$$

$$x^2 + \left(y + \frac{15}{2}\right)^2 = \frac{289}{4}$$

$$4x^2 + 4\left(y + \frac{15}{2}\right)^2 = 289$$

Students did not evaluate 8.5^2 .

Students must remember to simplify $(x-0)^2$ as x^2

- (iii) Calculate the height of the pillar CF . [2]

At $x = 3$,

$$3^2 + (y + 7.5)^2 = \frac{289}{4} \quad \text{M1}$$

$$(y + 7.5)^2 = \frac{253}{4}$$

$$y + 7.5 = \pm \sqrt{\frac{253}{4}}$$

$$y = 0.453 \text{ or } y = -15.5$$

$$\therefore \text{height of the pillar} = 0.453 \text{ m} \quad \text{A1}$$

Students did not know there are positive and negative values or did not answer to the question by stating clearing the height of the pillar.

- (iv) Find the equation of tangent at point
- B
- .

[3]

 PB is perpendicular to the tangent at point B .

$$\text{Gradient } PB = \frac{7.5}{4} = \frac{15}{8} \quad \text{M1}$$

$$\text{Gradient of tangent at point } B = -\frac{8}{15} \quad \text{M1}$$

Equation of tangent at B is

$$y = -\frac{8}{15}(x-4)$$

$$y = -\frac{8}{15}x + \frac{32}{15} \quad \text{A1}$$

$$15y = -8x + 32$$

Students are not aware that PB is perpendicular to tangent at B .
Some used differentiation to find gradient. waste time
Many students forgot the x in the final answer!!!

- 3 (a) Solve $\sqrt{4x+12} - \sqrt{x+3} = 2$. [3]

$$\begin{aligned} \sqrt{4x+12} - \sqrt{x+3} &= 2 & \sqrt{4x+12} &= 2 + \sqrt{x+3} & \text{M1} \\ \sqrt{4(x+3)} - \sqrt{x+3} &= 2 & 4x+12 &= 4 + 4\sqrt{x+3} + (x+3) \\ \text{M1 } 2\sqrt{x+3} - \sqrt{x+3} &= 2 & 3x+5 &= 4\sqrt{x+3} \\ \sqrt{x+3} &= 2 & 9x^2 + 30x + 25 &= 16(x+3) & \text{M1} \\ x+3 &= 4 & 9x^2 + 14x - 23 &= 0 \\ x &= 1 & \text{A1} & & x = 1 \text{ or } x = -\frac{23}{9} \text{ (NA)} \end{aligned}$$

A1 – must show both

Common errors:

Students square individual terms to remove square root. Never do that.

Students who square both sides of the equation must remember to check for validity of answers.

- (b) The volume of right circular cone is $4\pi \text{ cm}^3$. The radius of its base is $(1+\sqrt{2}) \text{ cm}$. Find, without the use of a calculator, the height of the cone in the form $(a+b\sqrt{2}) \text{ cm}$, where a and b are integers. [3]

$$\begin{aligned} \text{Vol of cone} &= \frac{1}{3}\pi r^2 h \\ 4\pi &= \frac{1}{3}\pi(1+\sqrt{2})^2 h & \text{M1} \\ 12 &= (1+2\sqrt{2}+2)h \\ h &= \frac{12}{(3+2\sqrt{2})} \times \frac{(3-2\sqrt{2})}{(3-2\sqrt{2})} & \text{M1} \\ &= \frac{12(3-2\sqrt{2})}{9-8} \\ &= 12(3-2\sqrt{2}) \\ &= 36-24\sqrt{2} & \text{A1} \end{aligned}$$

Some students do not know the volume to find volume of cone. Students must show how they rationalise the denominator.

- 4 A particle moving in a straight line, passes through a fixed point O with a velocity of 4 m/s. Its acceleration t seconds after passing through O , is $(6t - 8) \text{ m s}^{-2}$. Find

(i) the minimum velocity of the particle, [4]

$$a = (6t - 8)$$

$$v = \int 6t - 8 \, dt$$

$$= 3t^2 - 8t + c, c \text{ is an arbitrary constant M}$$

$$\text{At } t = 0, v = 4 \therefore c = 4$$

$$v = 3t^2 - 8t + 4 \quad \text{M1}$$

$$\text{Min velocity when } a = 0, t = \frac{8}{6} = \frac{4}{3} \quad \text{M1}$$

$$\text{At } t = \frac{4}{3}, \frac{d^2v}{dt^2} = 6 > 0$$

$$\therefore \text{minimum velocity, } v = 3\left(\frac{4}{3}\right)^2 - 8\left(\frac{4}{3}\right) + 4 = -\frac{4}{3} \text{ m/s} \quad \text{A1}$$

(ii) the time when the particle first comes to an instantaneous rest, [2]

$$v = 0$$

$$3t^2 - 8t + 4 = 0 \quad \text{M1}$$

$$(3t - 2)(t - 2) = 0$$

$$t = \frac{2}{3} \text{ or } t = 2$$

$$\therefore \text{it first comes to rest at } t = \frac{2}{3} \text{ s} \quad \text{A1}$$

(iii) the distance travelled in the 2nd second. [3]

$$s = \int_1^2 3t^2 - 8t + 4 \, dt \quad \text{M1}$$

$$= \left[t^3 - 4t^2 + 4t \right]_1^2 \quad \text{M1 or}$$

$$= [(8 - 16 + 8) - (1 - 4 + 4)]$$

$$= 1 \quad \text{A1}$$

$$s = t^3 - 4t^2 + 4t + c \quad \text{M1}$$

$$t = 0, s = 0 \therefore c = 0$$

$$\text{at } t = 1, s = 1 - 4 + 4 = 1$$

$$\text{at } t = 2, s = 8 - 16 + 8 = 0 \quad \text{M1}$$

$$\therefore \text{distance travelled} = 1 \text{ m} \quad \text{A1}$$

Generally well done but some students forgot to add the arbitrary constant.

Some students do not know that at $t = 0, v = 4$. They use $v = 0$ instead.

Question asked for min velocity, good to do second derivative to prove that it is min velocity.

Students did not know that min velocity happens when $a = 0$ and they should use this to find the value of t in order to find velocity.

Very well done as many know that $v = 0$ when particle is at instantaneous rest.

However, students did not answer the question. They must either reject $t = 2$ or show clearly that the answers

as required is $t = \frac{2}{3}$ as question asked for 'first at rest'.

Quite badly done.

Some students did not know they have to integrate velocity to find displacement function. Many integrate velocity without using definite integrals hence they have to calculate the unknown c , too much effort.

Students did not know how to find distance travelled in the 2nd second. They find

displacement at $t = \frac{2}{3}$ and $t = 2$ or they use $t = 2$ and $t = 3$.

Distance travelled in the 2nd second is the distance travelled between $t = 1$ and $t = 2$.

- 5 (i) Prove that $\operatorname{cosec}2x + \cot 2x = \cot x$. [3]

$$\begin{aligned}\operatorname{cosec}2x + \cot 2x &= \frac{1}{\sin 2x} + \frac{\cos 2x}{\sin 2x} \\ &= \frac{1 + \cos 2x}{\sin 2x} \quad \text{M1} \\ &= \frac{2\cos^2 x}{2\sin x \cos x} \quad \text{M1} \\ &= \frac{\cos x}{\sin x} \quad \text{A1} \\ &= \cot x\end{aligned}$$

A small handful of students wrote

$$\operatorname{cosec} x \text{ as } \frac{1}{\cos x}$$

Students rewrote as \sin , \cos and \tan but did not know how to simplify further.

- (ii) Hence, deduce the value of $\cot 15^\circ$ in surd form. [2]

$$\begin{aligned}\cot 15^\circ &= \operatorname{cosec}30^\circ + \cot 30^\circ \\ &= \frac{1}{\sin 30^\circ} + \frac{1}{\tan 30^\circ} \quad \text{M1} \\ &= \frac{1}{\frac{1}{2}} + \frac{1}{\frac{1}{\sqrt{3}}} \\ &= 2 + \sqrt{3} \quad \text{A1}\end{aligned}$$

Students did not notice this is a "Hence" question and did not use part (i). Zero immediately. Careless for some students.

- (iii) Using part (i), solve $\operatorname{cosec}2x + \cot 2x = 6 - 5 \tan x$ for $0^\circ \leq x \leq 360^\circ$ [4]

$$\begin{aligned}\operatorname{cosec}2x + \cot 2x &= 6 - 5 \tan x \\ \cot x &= 6 - 5 \tan x \quad \text{M1} \\ \frac{1}{\tan x} &= 6 - 5 \tan x \\ 5 \tan^2 x - 6 \tan x + 1 &= 0 \quad \text{M1} \\ (5 \tan x - 1)(\tan x - 1) &= 0 \\ \tan x &= \frac{1}{5} \quad \text{or} \quad \tan x = 1 \\ \alpha &= 11.30993^\circ \quad x = 45^\circ, 225^\circ \\ x &= 11.3^\circ, 191.3^\circ \quad \text{A1} \quad \text{A1}\end{aligned}$$

Pretty well done. Only a small handful needs to revise this topic of solving trigonometry equations. But it was horrifying to see:

$$5 \tan^2 x - 6 \tan x + 1 = 0$$

$$5 \tan^2 x - 6 \tan x = -1$$

$$\tan x(5 \tan x - 6) = -1$$

$$\tan x = -1 \text{ or } 5 \tan x - 6 = -1$$



- 6 (a) It is given that $g(x) = 2e^x - 3\sqrt{e^x}$. Solve the equation $g(x) + 1 = 0$. [4]

$$2e^x - 3\sqrt{e^x} + 1 = 0$$

$$\text{Let } p = e^{\frac{1}{2}x},$$

$$2p^2 - 3p + 1 = 0 \quad \text{M1}$$

$$(2p-1)(p-1) = 0$$

$$p = \frac{1}{2}$$

$$e^{\frac{1}{2}x} = \frac{1}{2}$$

$$\frac{1}{2}x = \ln\left(\frac{1}{2}\right)$$

$$x = -1.39 \quad \text{A1}$$

Most glaring error: Students square individual terms to remove square root. WHY WHY WHY???

$$p = 1 \quad \text{M1}$$

$$e^{\frac{1}{2}x} = 1$$

$$\frac{1}{2}x = 0$$

$$x = 0 \quad \text{A1}$$

- (b) The function $f(x)$ is such that $f'(x) = 3e^x + e^{-2x}$.

- (i) Given that $f(0) = 4$, find an expression for $f(x)$. [3]

$$f'(x) = 3e^x + e^{-2x}$$

$$f(x) = \int 3e^x + e^{-2x} dx$$

$$= 3e^x - \frac{e^{-2x}}{2} + c \quad \text{M1}$$

$$f(0) = 4$$

$$4 = 3e^0 - \frac{1}{2}e^0 + c \quad \text{M1}$$

$$4 = 3 - \frac{1}{2} + c$$

$$c = \frac{3}{2}$$

$$\therefore f(x) = 3e^x - \frac{e^{-2x}}{2} + \frac{3}{2} \quad \text{A1}$$

Student integrate wrongly. Did not divide by -2. Or forgot to add constant c.
Did not calculate c value accurately

- (ii) Show that $\int_{-\ln 2}^0 f'(x) dx = k$, where k is a constant to be determined. [3]

$$\int_{-\ln 2}^0 f'(x) dx = k$$

$$\left[3e^x - \frac{1}{2}e^{-2x} \right]_{-\ln 2}^0 = k \quad \text{M1}$$

$$k = \left[\left(3e^0 - \frac{1}{2}e^0 \right) - \left(3e^{-\ln 2} - \frac{1}{2}e^{-2\ln 2} \right) \right]$$

$$= 2\frac{1}{2} - \left(\frac{3}{2} - \frac{1}{2} \times 4 \right)$$

$$= 3 \quad \text{A1}$$

Students Sub values in without using $f(x)$
Students used wrong values when doing substitution. Ln 2 instead of $-\ln 2$
Most common error: students include c value which is $3/2$ when evaluating definite integrals.
Student must show how values are substituted before giving final answer.

- 7 (a) (i) An equation of a curve is $y = x^4 + 2x^3$. Find the coordinates of the stationary points and determine the nature of the stationary points. [5]

$$y = x^4 + 2x^3$$

$$\frac{dy}{dx} = 4x^3 + 6x^2 \quad \text{M1}$$

$$\frac{dy}{dx} = 0$$

$$2x^2(2x+3) = 0$$

$$x = 0 \quad \text{or} \quad x = -\frac{3}{2}$$

$$\frac{d^2y}{dx^2} = 12x^2 + 12x \quad \text{M1}$$

$$\text{At } x = -\frac{3}{2}, \frac{d^2y}{dx^2} = 9 > 0$$

$$\text{At } x = -\frac{3}{2}, y = -\frac{27}{16}$$

$$\left(-\frac{3}{2}, -\frac{27}{16}\right) \text{ is a minimum point} \quad \text{A1}$$

	$x < 0$	$x = 0$	$x > 0$	
$\frac{dy}{dx}$	+ve	0	+ve	M1

(0, 0) is a point of inflexion

A1

Students do not know that they must use first derivative test to conclude for point of inflexion.

Some cannot remember the name or spell the point the inflexion.

- (ii) Explain whether y is increasing or decreasing for $-1.5 < x < 0$. [2]

$$\frac{dy}{dx} = 4x^3 + 6x^2 = 2x^2(2x+3)$$

$$x^2 > 0, -\frac{3}{2} < x < 0 \quad \text{M1}$$

$$(2x+3) > 0$$

$$\therefore \frac{dy}{dx} > 0 \quad \text{A1}$$

y is an increasing function for $-1.5 < x < 0$.

Most students cannot do this.

OR

	$x = -1.5$	$x > -1.5$	$x < 0$	$x = 0$
$\frac{dy}{dx}$	0	+ve	+ve	0

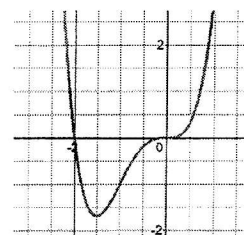

Describe clearly that gradient of graph of $x > -1.5$ is positive and the gradient of graph less than zero is also positive, hence y is an increasing function for $-1.5 < x < 0$.

- 7 (b) Two variables x and y are related by the equation $8y = \left(\frac{x}{2} - 1\right)^4$. Given that both x and y vary with time, find the value of x at the instant when the rate of change of y is twice the rate of change of x . [3]

$$y = \frac{1}{8} \left(\frac{x}{2} - 1\right)^4$$

$$\frac{dy}{dx} = \frac{1}{8} \times 4 \left(\frac{x}{2} - 1\right)^3 \left(\frac{1}{2}\right)$$

$$= \frac{1}{4} \left(\frac{x}{2} - 1\right)^3 \quad \text{M1}$$

$$\frac{dy}{dt} = 2 \left(\frac{dx}{dt}\right)$$

$$2 \left(\frac{dx}{dt}\right) = \frac{1}{4} \left(\frac{x}{2} - 1\right)^3 \left(\frac{dx}{dt}\right)$$

$$2 = \frac{1}{4} \left(\frac{x}{2} - 1\right)^3 \quad \text{M1}$$

$$8 = \left(\frac{x}{2} - 1\right)^3$$

$$\frac{x}{2} - 1 = 2$$

$$\frac{x}{2} = 3$$

$$x = 6 \quad \text{A1}$$

Some students actually did binomial expansion before differentiation – waste time.

Some do not know what is the rate of change of y is twice the rate of change of x .

- 8 The population P , in millions, of a country was recorded on January of the various years and the results are shown in the table below.

Year	2005	2010	2015	2020
P	12.95	14.67	17.52	22.11

Given that $P = 10 + ab^t$, where t is the time measured in years from 2000 and a and b are constants.

$$\lg(P - 10) = \lg a + \lg b$$

- (i) Draw the graph of $\lg(P - 10)$ plotted against t , for $0 \leq t \leq 25$. [3]

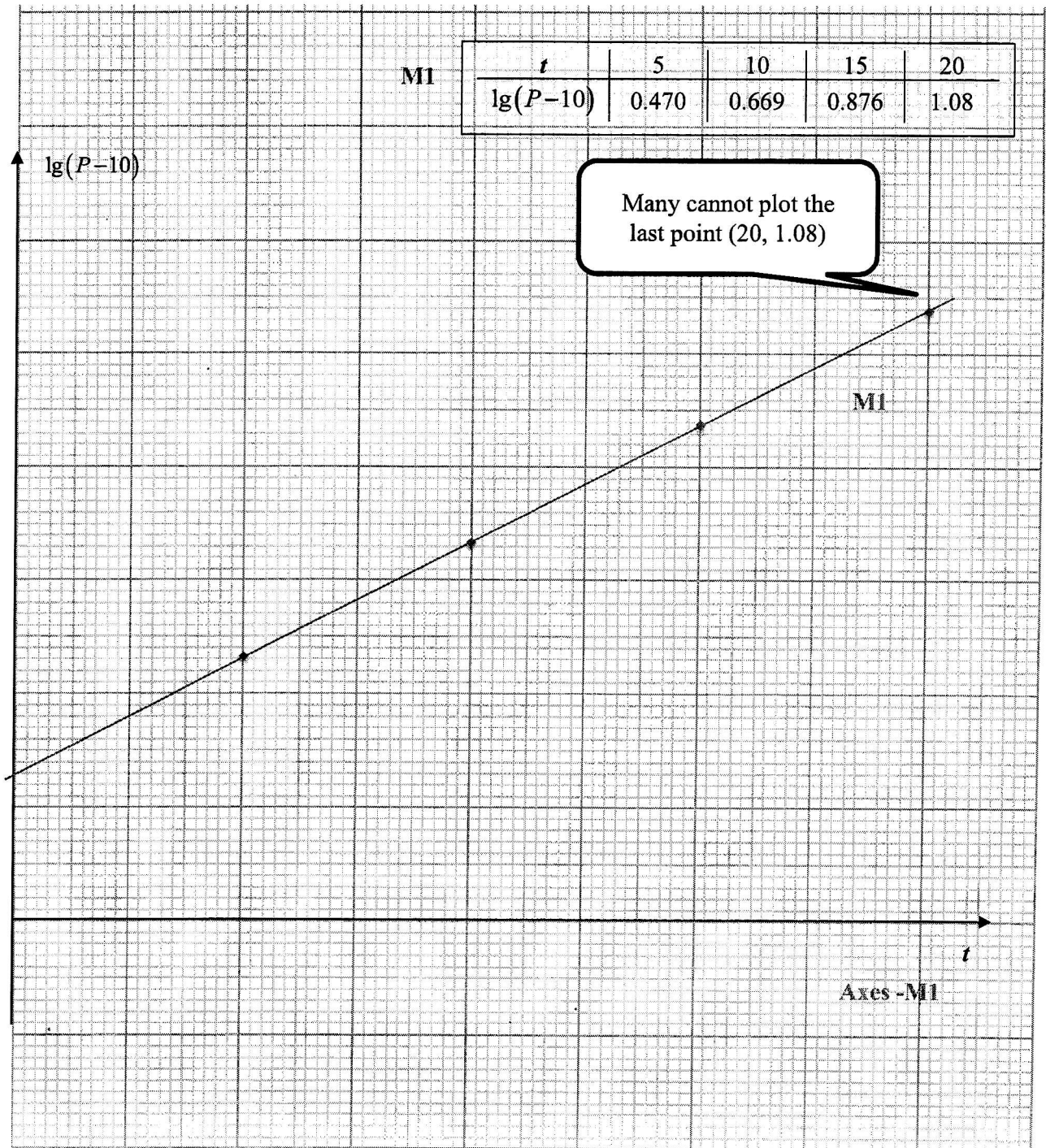

- 8 (ii) Use the graph to estimate the values of a and b . [4]

$$P = 10 + ab^t$$

$$P - 10 = ab^t$$

$$\lg(P - 10) = \lg a + t \lg b$$

$\lg b$ is the gradient

$$\lg b = \frac{1.08 - 0.27}{20} \quad \text{M1}$$

$$= 0.0405$$

$$b = 1.09$$

$$[0.0405 \leq \lg b \leq 0.0415]$$

$$1.09 \leq b \leq 1.1 \quad \text{A1}$$

$\lg a$ is the vertical intercept

$$\lg a = 0.27$$

$$a = 1.86 \quad \text{A1}$$

$$[0.25 \leq \lg a \leq 0.27]$$

$$1.78 \leq a \leq 1.86$$

Quite good except those whose last point is out, then gradient is off.

- (iii) Explain how the graph could be used to find the year in which the population will reach 33.6 millions. [2]

To reach population of 33.6 millions, take $\lg(33.6 - 10) = \lg 23.6$
 $= 1.37$

1. Draw a horizontal line $\lg(P - 10) = 1.37$ M1
2. The point of intersection with the linear graph will give you value t .
3. The year is $2000 + t$ A1

Quite good just that some forgot the last point.

9 Solution to this question by accurate drawing will not be accepted.

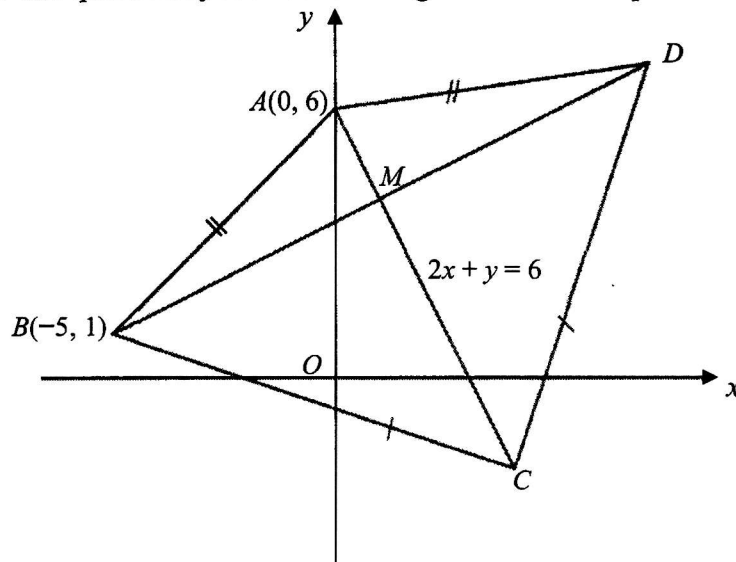

The diagram shows a kite $ABCD$ with $AB = AD$ and $CB = CD$. The diagonals intersect at M . It is given that the coordinates of A and B are $(0, 6)$ and $(-5, 1)$ respectively and the equation of AC is $2x + y = 6$.

Find

- (i) the equation of BD . [2]

Gradient of $BD = \frac{1}{2}$ M1

Equation of BD is

$$y - 1 = \frac{1}{2}(x + 5)$$

$$y = \frac{1}{2}x + \frac{7}{2} \quad \text{A1}$$

$$2y = x + 7$$

Quite well done

- (ii) the coordinates of M and of D . [4]

$$2x + y = 6 \dots\dots (1)$$

$$y = \frac{1}{2}x + \frac{7}{2} \dots\dots (2)$$

$$6 - 2x = \frac{1}{2}x + \frac{7}{2} \quad \text{M1}$$

$$\frac{5}{2}x = \frac{12 - 7}{2}$$

$$x = 1$$

$$y = 4$$

$$M(1, 4) \quad \text{A1}$$

Midpoint $BD = M$

$$\left(\frac{-5 + x}{2}, \frac{1 + y}{2} \right) = (1, 4) \quad \text{M1}$$

$$\frac{-5 + x}{2} = 1 \qquad \frac{1 + y}{2} = 4$$

$$-5 + x = 2 \qquad 1 + y = 8$$

$$x = 7 \qquad y = 7$$

$$D(7, 7) \quad \text{A1}$$

Quite well done for coordinate of M but many failed to use mid point to find D

- 9 Given further that the area of the triangle ABD is $\frac{1}{3}$ of the area of the triangle CBD ,
 (iii) find the coordinates of C , [2]

By similar Δ s,

$$\frac{1}{x} = \frac{1}{4} \quad \text{M1}$$

$$x = 4$$

Or

$$\sqrt{x^2 + (2x)^2} = 4\sqrt{1^2 + 2^2} \quad \text{M1}$$

$$\sqrt{5x^2} = 4\sqrt{5}$$

$$5x^2 = 80$$

$$x = 4$$

A1 $C = (4, -2)$

Some use area of triangle to find C .

Some use similar triangle/vector but use 1:3 instead of 1:4

- (iv) find the area of the kite $ABCD$. [2]

Area of kite $ABCD =$

$$\frac{1}{2} \begin{vmatrix} -5 & 4 & 7 & 0 & -5 \\ 1 & -2 & 7 & 6 & 1 \end{vmatrix} = \frac{1}{2} [(10 + 28 + 42) - (4 - 14 - 30)]$$

M1

$$= \frac{1}{2} [120]$$

$$= 60 \text{ units}^2 \quad \text{A1}$$

Some actually use area of triangle ABD and multiple by 3

- 10 (i) Solve the equation $4\cos 2A = 3 - 2\sin A$ for $0 \leq A \leq 2\pi$. [4]

$$4\cos 2A = 3 - 2\sin A$$

$$4(1 - 2\sin^2 A) = 3 - 2\sin A \quad \text{M1}$$

$$4 - 8\sin^2 A = 3 - 2\sin A$$

$$8\sin^2 A - 2\sin A - 1 = 0$$

$$(4\sin A + 1)(2\sin A - 1) = 0 \quad \text{M1}$$

$$\sin A = -\frac{1}{4}$$

basic \angle , $\alpha = 0.25268$

$$\begin{aligned} \angle A &= \pi + \alpha, 2\pi - \alpha \\ &= 3.39, 6.03 \quad \text{A1} \end{aligned}$$

$$\sin A = \frac{1}{2}$$

$$A = \frac{\pi}{6}, \frac{5\pi}{6} \quad \text{A1}$$

Quite well done.

- (ii) It is given that $f(x) = 2\cos 6x - \frac{1}{2}$ and $g(x) = 1 - \sin 3x$. State the period of $f(x)$ and $g(x)$, in terms of π . [2]

$$\text{Period of } f(x) = \frac{2\pi}{6} = \frac{\pi}{3} \quad \text{B1}$$

$$\text{Period of } g(x) = \frac{2\pi}{3} \quad \text{B1}$$

Quite well done.

- 10 (iii) Sketch, on the same axes, the graphs of for $y = f(x)$ and $y = g(x)$ for

$$0 \leq x \leq \frac{2\pi}{3}.$$

[4]

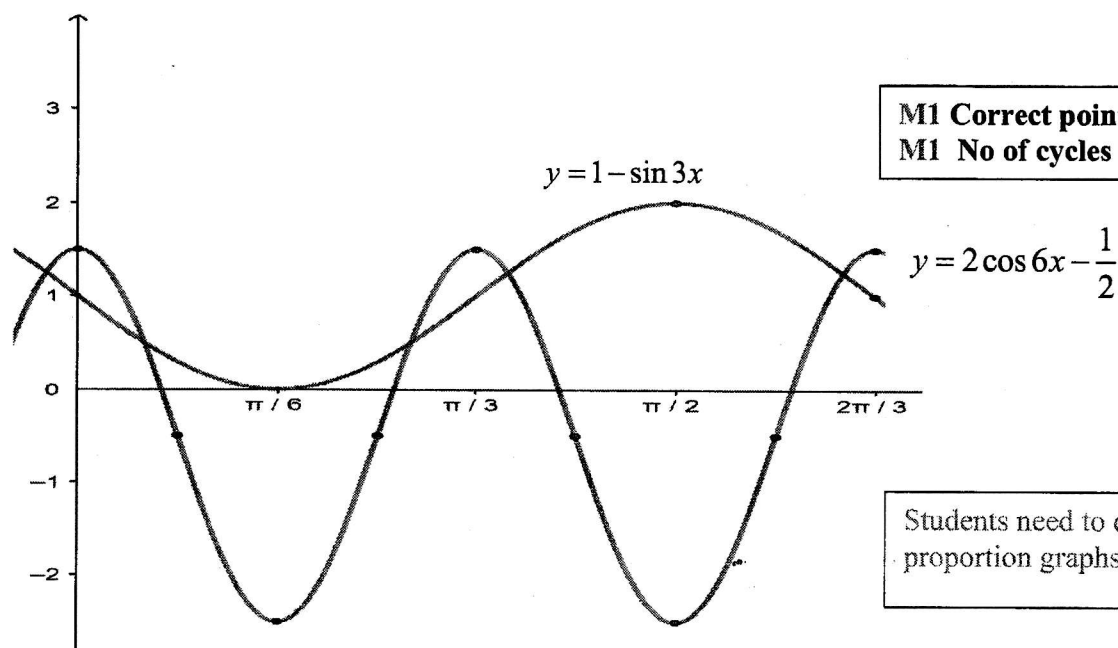

M1 Correct points/shapes
M1 No of cycles

Students need to draw more
proportion graphs

- (iv) Explain how the solutions of the equations in part (i) could be used to find the x -coordinates of the points of intersection of the graphs of (ii). [2]

$$2 \cos 6x - \frac{1}{2} = 1 - \sin 3x$$

$$4 \cos 6x - 1 = 2 - 2 \sin 3x$$

$$4 \cos 6x = 3 - 2 \sin 3x$$

$$\text{Let } 3x = A$$

$$4 \cos 2A = 3 - 2 \sin A$$

M1

Badly done. Most cannot
explain.

The solutions in part (i) divided by 3 will be the x coordinates of the points of intersection of the graphs of (ii) A1

~ End of Paper ~

Blank Page