

*Visit*

**FREETESTPAPER.com**

*for more papers*



Website: [freetestpaper.com](http://www.freetestpaper.com)



[Facebook.com/freetestpaper](https://www.facebook.com/freetestpaper)



[Twitter.com/freetestpaper](https://www.twitter.com/freetestpaper)



**ZHONGHUA SECONDARY SCHOOL**  
**PRELIMINARY EXAMINATION 2021**  
**SECONDARY 4 EXPRESS**

Candidate's Name	Class	Register Number

**ADDITIONAL MATHEMATICS**

**4049/01**

PAPER 1

13 Sep 2021  
2 hours and 15 minutes

Candidates answer on the Question Paper.

**READ THESE INSTRUCTIONS FIRST**

Write your name, class and register number on all the work you hand in.  
Write in dark blue or black pen on both sides of the paper.  
You may use an HB pencil for any diagrams or graphs.  
Do not use paper clips, glue or correction fluid.

Answer **all** questions.

If working is needed for any question, it must be shown with the answer.  
Omission of essential working will result in loss of marks.  
The use of an approved scientific calculator is expected, where appropriate.  
If the degree of accuracy is not specified in the question, and if the answer is not exact, give the answer to three significant figures. Give answers in degrees to one decimal place.  
For  $\pi$ , use either your calculator value or 3.142, unless the question requires the answer in terms of  $\pi$ .

The number of marks is given in brackets [ ] at the end of each question or part question.  
The total of the marks for this paper is **90**.

Setter: Mr Ardy Taniwan  
Vetted by: Mr Poh Wei Beng

For Examiner's Use
<b>90</b>



## 1. ALGEBRA

*Quadratic Equation*

For the equation  $ax^2 + bx + c = 0$

$$x = \frac{-b \pm \sqrt{b^2 - 4ac}}{2a}$$

*Binomial expansion*

$$(a + b)^n = a^n + \binom{n}{1} a^{n-1} b + \binom{n}{2} a^{n-2} b^2 + \dots + \binom{n}{r} a^{n-r} b^r + \dots + b^n,$$

where  $n$  is a positive integer and  $\binom{n}{r} = \frac{n!}{r!(n-r)!} = \frac{n(n-1)\dots(n-r+1)}{r!}$

## 2. TRIGONOMETRY

*Identities*

$$\sin^2 A + \cos^2 A = 1$$

$$\sec^2 A = 1 + \tan^2 A$$

$$\operatorname{cosec}^2 A = 1 + \cot^2 A$$

$$\sin(A \pm B) = \sin A \cos B \pm \cos A \sin B$$

$$\cos(A \pm B) = \cos A \cos B \mp \sin A \sin B$$

$$\tan(A \pm B) = \frac{\tan A \pm \tan B}{1 \mp \tan A \tan B}$$

$$\sin 2A = 2 \sin A \cos A$$

$$\cos 2A = \cos^2 A - \sin^2 A = 2 \cos^2 A - 1 = 1 - 2 \sin^2 A$$

$$\tan 2A = \frac{2 \tan A}{1 - \tan^2 A}$$

*Formulae for  $\Delta ABC$* 

$$\frac{a}{\sin A} = \frac{b}{\sin B} = \frac{c}{\sin C}$$

$$a^2 = b^2 + c^2 - 2bc \cos A$$

$$\Delta = \frac{1}{2} bc \sin A$$

**1 Do not use a calculator in this question.**

(a) Given that  $A$  and  $B$  are acute angles such that  $\sin(A - B) = \frac{3}{8}$  and  $\sin A \cos B = \frac{5}{8}$ , find the value of

(i)  $\cos A \sin B$ , [2]

(ii)  $\cot A \tan B$ . [2]

- 1 (b) Given that  $\tan A = -\frac{3}{4}$  and  $\cos B = \frac{5}{13}$ , where  $A$  is an obtuse angle and  $B$  is a reflex angle, find
- (i)  $\cos 2A$ , [2]

- (ii)  $\tan(A - B)$ . [2]

- 2 Given that  $\sqrt{p+q\sqrt{8}} = \frac{9}{4-\sqrt{8}}$ , where  $p$  and  $q$  are rational numbers, find the values of  $p$  and  $q$ . [4]

- 3 Baking powder is poured onto a flat surface at a constant rate of  $2\pi \text{ cm}^3\text{s}^{-1}$  and formed a right circular cone. The radius of the cone is always  $\frac{1}{18}$  of its height. Find the rate of change of the radius of the cone after 3 seconds of pouring. [5]

- 4 (a) The quantity,  $N$ , of a micro-organism multiply themselves under ideal conditions based on the formula  $N = N_0 e^{\frac{t}{7}}$  where  $N_0$  is a constant and  $t$  is the time interval in minutes. Find the time taken for the quantity of the micro-organism to be twice of the initial quantity. [3]

- (b) In order to obtain a graphical solution for the equation  $x = -2 \log_9(3 - x)$ , a straight line graph has to be drawn on the graph of  $y = 3^{-x}$ . Find the equation of the straight line that need to be drawn. [3]

5 The roots of a cubic equation  $F(x)=0$  are  $-1, 2$  and  $5$ . When  $F(x)$  is divided by  $x-3$ , the remainder is  $30$ .

(i) Find the remainder when  $F(x)$  is divided by  $x+3$ . [4]

(ii) Solve the equation  $F(\sqrt{m})=0$ . [2]

- 6 (a) The graph below shows part of a trigonometric function.

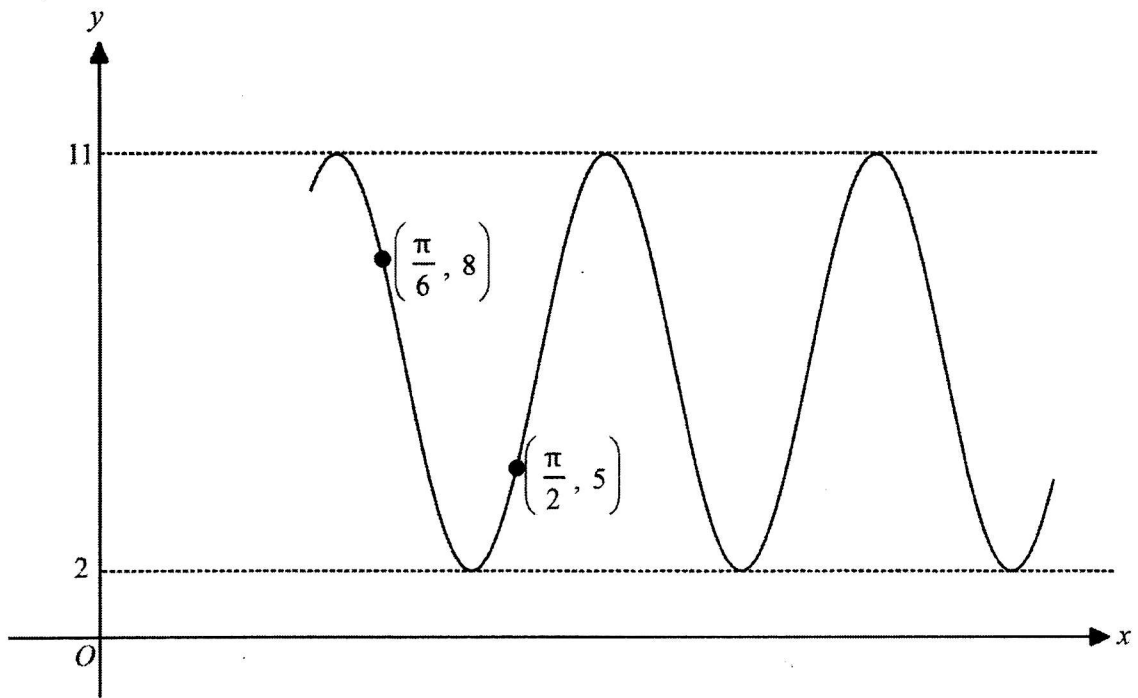

- (i) State the amplitude and period of the function. [2]

- (ii) Explain why the graph cannot represent the tangent function. [1]

6 (b) (i) Sketch the graph of  $y = -4\sin 3x + 2$  for  $0^\circ \leq x \leq 360^\circ$ . [3]

(ii) State the number of solutions for the equation  $5 = -4\sin 6x + 2$  for  $0^\circ \leq x \leq 360^\circ$ .

[1]

7 A curve has the equation  $y = f(x)$ , where  $f(x) = \frac{5x+11}{x^2+3}$ .

(i) Find the equation of normal to the curve at the point where the curve passes through the  $y$ -axis. [6]

(ii) Determine the range of values of  $x$  for which  $f(x)$  is a decreasing function. [3]

8 (i) Prove the identity  $\frac{\sin 2x}{\sin x} - \frac{\cos 2x}{\cos x} = \sec x$ . [3]

(ii) Solve the equation  $\frac{2\sin 2x}{\sin x} - \frac{2\cos 2x}{\cos x} = 3\cos x + 1$  for  $0^\circ < x < 360^\circ$ . [4]

- 9 A particle travels in a straight line so that  $t$  seconds after passing a fixed point  $O$  with a velocity of  $15 \text{ cms}^{-1}$ , its acceleration  $a \text{ cms}^{-2}$  is given by  $a = k - 2t$  where  $k$  is a constant. The particle reaches maximum velocity in 1 second.

Find

- (i) the value of  $k$ , [1]

- (ii) an expression for the velocity,  $v$ , in terms of  $t$ , [3]

- (iii) the distance travelled in the first 10 seconds. [4]

10  $f(x)$  is such that  $f'(x) = -2\sin 4x + \cos 3x$ .

Given that  $f(0) = 0$ , find the exact value of  $f\left(\frac{\pi}{4}\right)$ .

[6]

- 11 The diagram shows a triangle  $PQR$  circumscribed in a circle.  $PQ = 10$  cm,  $QR = x$  cm and  $PR$  is the diameter of the circle.

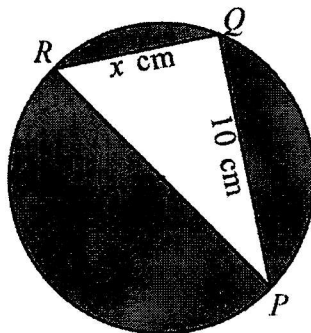

- (i) Explain why the area of shaded regions,  $A$  cm<sup>2</sup>, is  $25\pi + \frac{\pi}{4}x^2 - 5x$ . [4]

- (ii) Given that  $x$  can vary, find the minimum area of the shaded region. [3]

- 12 Given that the expansion of  $\left(1 + \frac{x}{2}\right)^n (3 - 2x)$  up to the first three terms, in ascending powers of  $x$ , is  $h + 10x + kx^2$ , find the values of  $h$ ,  $k$  and  $n$ . [7]

- 13 The diagram below shows a trapezium  $OABC$ , where  $O$  is the origin.

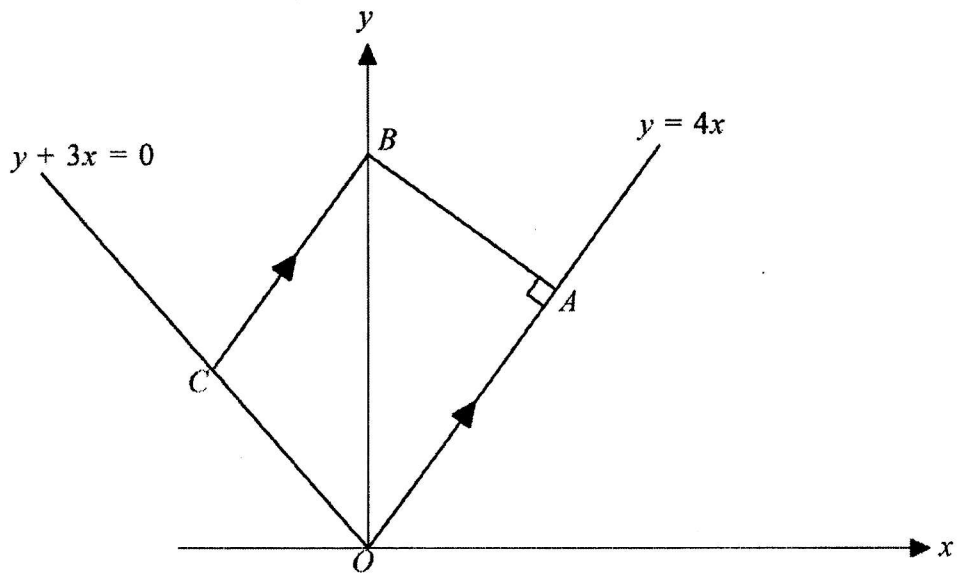

The equation of  $AO$  is  $y = 4x$  and the equation of  $OC$  is  $y + 3x = 0$ .

The line through  $A$  perpendicular to  $OA$  meets  $y$ -axis at  $B$  and  $BC$  is parallel to  $AO$ .

Given that the length of  $OA$  is  $\sqrt{1700}$  units, find the coordinates of  $A$ , of  $B$  and of  $C$ . [10]

P1 ONs at the back 18

Continuation of working space for Question 13.

~~~~ *End of Paper* ~~~~

**Answers:**

1ai.  $\frac{1}{4}$

1aii.  $\frac{2}{5}$

1bi.  $\frac{7}{25}$

1bii.  $\frac{33}{56}$

2.  $p = \frac{243}{8}$      $q = \frac{81}{8}$

3.  $\frac{1}{9}$  cm/s

4a. 4.85 minutes

4b.  $y = 3 - x$

5i. 300

5ii.  $m = 4$      $m = 25$

6ai. amplitude = 4.5    period =  $\frac{2}{3}\pi$

6aii. Because the graph is continuous  
Because the graph has maximum and minimum  
Because the graph does not have asymptote lines

6bi.

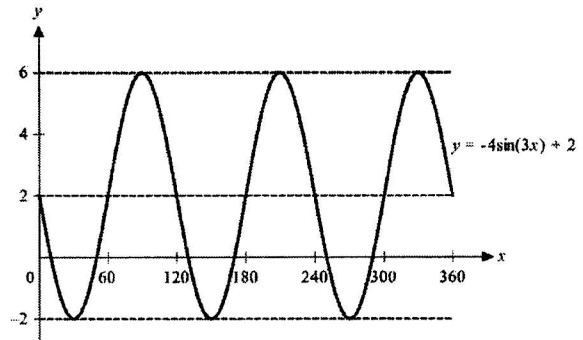

6bii. 12 solutions

7i.  $y = -\frac{3}{5}x + \frac{11}{3}$

7ii.  $x < -5$  or  $x > \frac{3}{5}$

8ii.  $48.2^\circ, 180^\circ, 311.8^\circ$

9i.  $k = 2$

9ii.  $v = -t^2 + 2t + 15$

9iii. 200 m

10.  $\frac{1}{6}\sqrt{2} - 1$

11ii.  $70.6 \text{ cm}^2$

12.  $h = 3$      $n = 8$      $k = 13$

13.  $A(10, 40)$

$B(0, 42.5)$

$C\left(-\frac{85}{14}, \frac{255}{14}\right)$



**ZHONGHUA SECONDARY SCHOOL**  
**PRELIMINARY EXAMINATION 2021**  
**SECONDARY 4 EXPRESS**

| Candidate's Name | Class | Register Number |
|------------------|-------|-----------------|
|                  |       |                 |

**ADDITIONAL MATHEMATICS**

**4049/02**

PAPER 2

14 September 2021  
2 hours 15 minutes

**Candidates answer on the Question Paper**

**READ THESE INSTRUCTIONS FIRST**

Write your name, class and register number on all the work you hand in.  
Write in dark blue or black pen on both sides of the paper.  
You may use an HB pencil for any diagrams or graphs.  
Do not use staples, paper clips, glue or correction fluid.

Answer **all** the questions.

Give non-exact numerical answers correct to 3 significant figures, or 1 decimal place in the case of angles in degrees, unless a different level of accuracy is specified in the question.

The use of a scientific calculator is expected, where appropriate.

You are reminded of the need for clear presentation in your answers.

The number of marks is given in brackets [ ] at the end of each question or part question.

The total number of marks for this paper is **90**.

| For Examiner's Use |
|--------------------|
| 90                 |

Setter: Ms Lee SK  
Vetted by: Mr Poh WB

This question paper consists of **20** printed pages (including this cover page)

## Mathematical Formulae

### 1. ALGEBRA

#### Quadratic Equation

For the equation  $ax^2 + bx + c = 0$ ,

$$x = \frac{-b \pm \sqrt{b^2 - 4ac}}{2a}$$

#### Binomial Theorem

$$(a+b)^n = a^n + \binom{n}{1}a^{n-1}b + \binom{n}{2}a^{n-2}b^2 + \dots + \binom{n}{r}a^{n-r}b^r + \dots + b^n,$$

where  $n$  is a positive integer and  $\binom{n}{r} = \frac{n!}{(n-r)!r!} = \frac{n(n-1)\dots(n-r+1)}{r!}$

### 2. TRIGONOMETRY

#### Identities

$$\sin^2 A + \cos^2 A = 1.$$

$$\sec^2 A = 1 + \tan^2 A.$$

$$\operatorname{cosec}^2 A = 1 + \cot^2 A.$$

$$\sin(A \pm B) = \sin A \cos B \pm \cos A \sin B$$

$$\cos(A \pm B) = \cos A \cos B \mp \sin A \sin B$$

$$\tan(A \pm B) = \frac{\tan A \pm \tan B}{1 \mp \tan A \tan B}$$

$$\sin 2A = 2 \sin A \cos A$$

$$\cos 2A = \cos^2 A - \sin^2 A = 2 \cos^2 A - 1 = 1 - 2 \sin^2 A$$

$$\tan 2A = \frac{2 \tan A}{1 - \tan^2 A}$$

#### Formulae for $\triangle ABC$

$$\frac{a}{\sin A} = \frac{b}{\sin B} = \frac{c}{\sin C}$$

$$a^2 = b^2 + c^2 - 2bc \cos A$$

$$\Delta = \frac{1}{2} ab \sin C$$

Answer all questions

**1** (i) Differentiate  $x \cos 2x$  with respect to  $x$ . [3]

---

(ii) Using your answer to part (i), find  $\int_{\pi}^{2\pi} x \sin 2x dx$ . [5]

2

(i) Express  $\frac{4x^3 + 5x^2 + x - 1}{x^2(x+1)}$  in partial fractions.

[5]

(ii) Hence, find  $\int \frac{4x^3 + 5x^2 + x - 1}{x^2(x+1)} dx$ .

[3]

3 It is given that  $4^{2x+3} = 7^{3-x}$ .

(i) Without using logarithms, find the exact value of  $112^x$ . [3]

(ii) Hence use your results in (i), solve  $4^{2x+3} = 7^{3-x}$ , giving your answer correct to 2 decimal places. [2]

4

The equation of a curve is  $y = (p + 2)x^2 - 10x + 2p + 1$ , where  $p$  is a constant.

(i) In the case where  $p = 2$ , find the set of values of  $x$  for which the curve lies above the line  $y = 1$ .

[3]

- 4 (ii) Find the range of values of  $p$  for which the curve lies completely below the line  $y = 2x + 3$ . [6]

5 Solve the equation  $\log_{16}(3x-16) - \log_4(2x) = 5\log_4(0.5)^{0.5}$ .

[5]

6 (i) Factorise  $(2 + x)^3 - 216$  completely.

[2]

(ii) Hence show that  $(2 + x)^3 - 216 = (x - 4)^2$  has exactly one real root.

[4]

- 7 The diagram shows part of the curve  $y = \sqrt{1+3x}$ , intersecting the  $y$ -axis at  $A$ . The tangent to the curve at the point  $P(5, 4)$  intersects the  $y$ -axis at  $B$ .

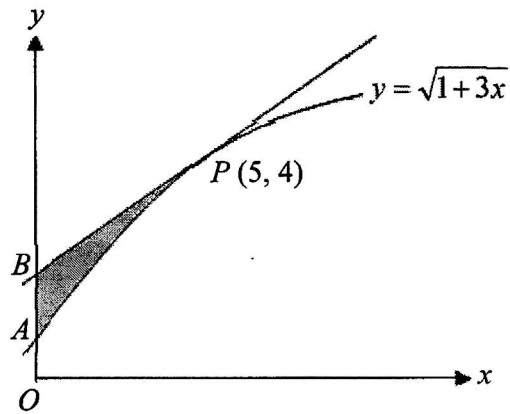

- (i) Find the coordinates of  $A$  and of  $B$ .

[4]

7 (ii) Calculate the area of the shaded region  $ABP$ .

[4]

- 8 The diagram shows two points  $A(-6, 2)$  and  $B(10, 2)$  on the circumference of a circle whose centre,  $C$ , lies above the  $x$ -axis. The line  $x = -8$  is a tangent to the circle.

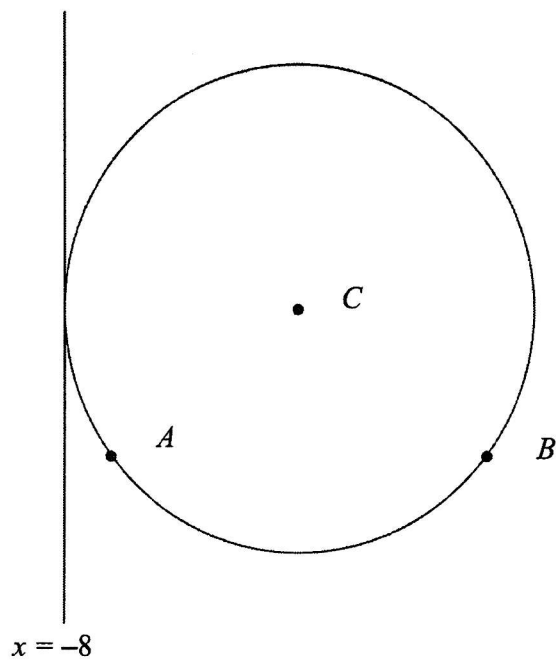

- (i) Show that the radius of the circle is 10 units.

[3]

**8** (ii) Find the equation of the circle.

[4]

(iii) Find the equations of the tangents to the circle parallel to the  $x$ -axis.

[2]

9 The equation of the curve is  $y = \frac{e^{2x}}{3+4x}$ .

(i) Find the coordinates of the stationary point on the curve, leaving your answer in exact value.

[4]

(ii) Determine the nature of this stationary point.

[2]

**10** In order for  $y = h(1 + x)^k$ , where  $h$  and  $k$  are unknown constants to be represented by a straight line graph, it needs to be expressed in the form  $Y = mX + c$ , where  $X$  and  $Y$  are functions of  $x$  and/or  $y$ , and  $m$  and  $c$  are constants.

(i) Determine an expression for  $Y$  and for  $X$ . [2]

(ii) Explain how the straight line may be used to determine the value of  $h$ . [1]

- 11 The variables  $x$  and  $y$  are known to be related by an equation of the form

$$\frac{x+2}{a} + \frac{y^2}{b} = 1, \text{ where } a \text{ and } b \text{ are constants.}$$

Experimental values of  $x$  and  $y$  are shown in the following table.

One of the values of  $y$  is subject to an abnormally large error.

|     |      |      |      |      |      |
|-----|------|------|------|------|------|
| $x$ | 1    | 2    | 3    | 4    | 5    |
| $y$ | 2.65 | 3.00 | 3.32 | 3.71 | 3.87 |

- (i) On the grid on page 17, draw the graph of  $y^2$  against  $x + 2$ .

[3]

- (ii) Use the graph to identify the coordinates for the abnormal reading in the table above [2]

and estimate its correct  $y$ -value.

- (iii) Use the graph to estimate the value of  $a$  and  $b$ .

[3]

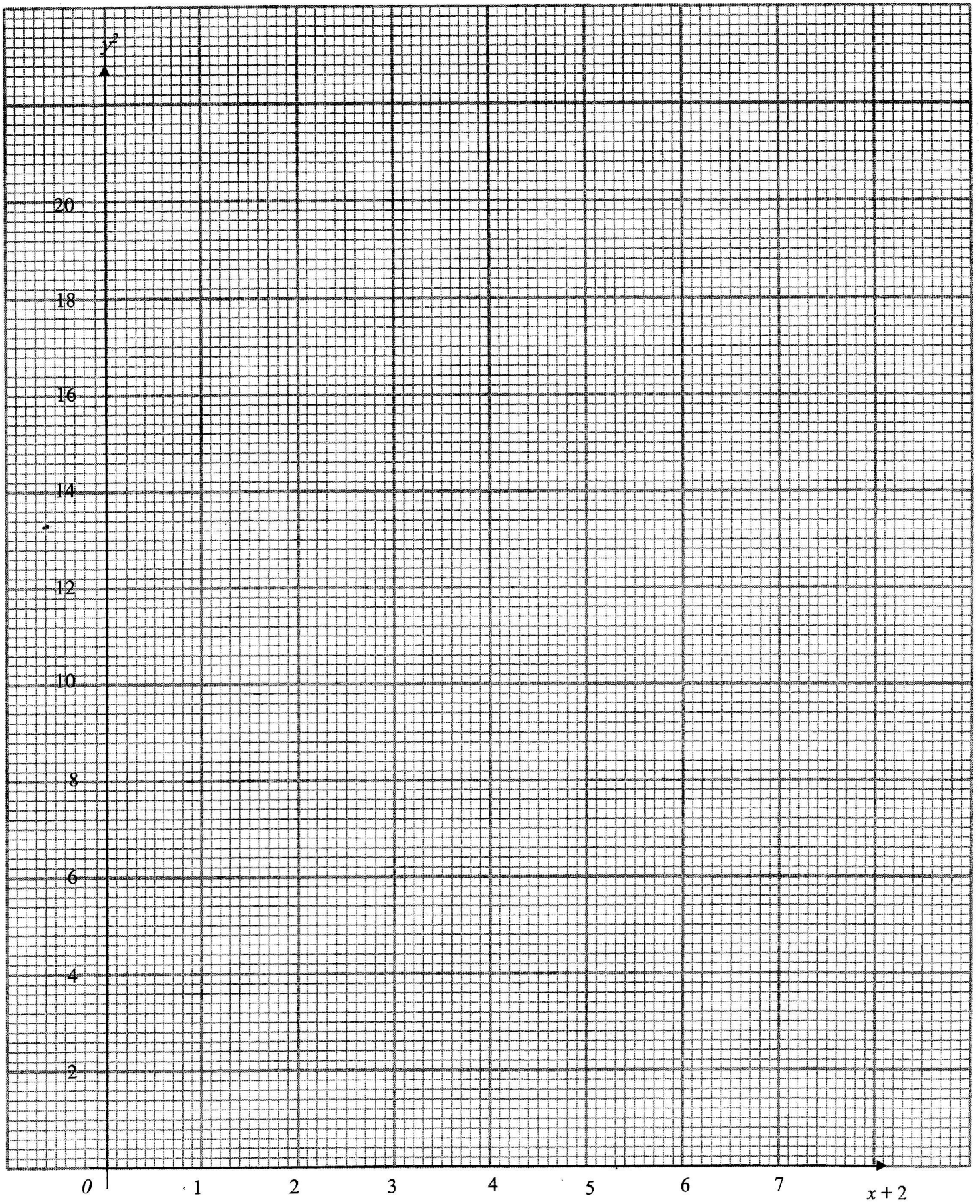

12

The diagram shows a rock climbing wall. The wall  $AB$ , of length 20 m, is to be inclined at an angle  $\theta$  from the vertical while the wall  $BC$ , of length 9 m, is to be inclined at the same angle  $\theta$  from the horizontal. The height of the whole wall is  $H$  m.

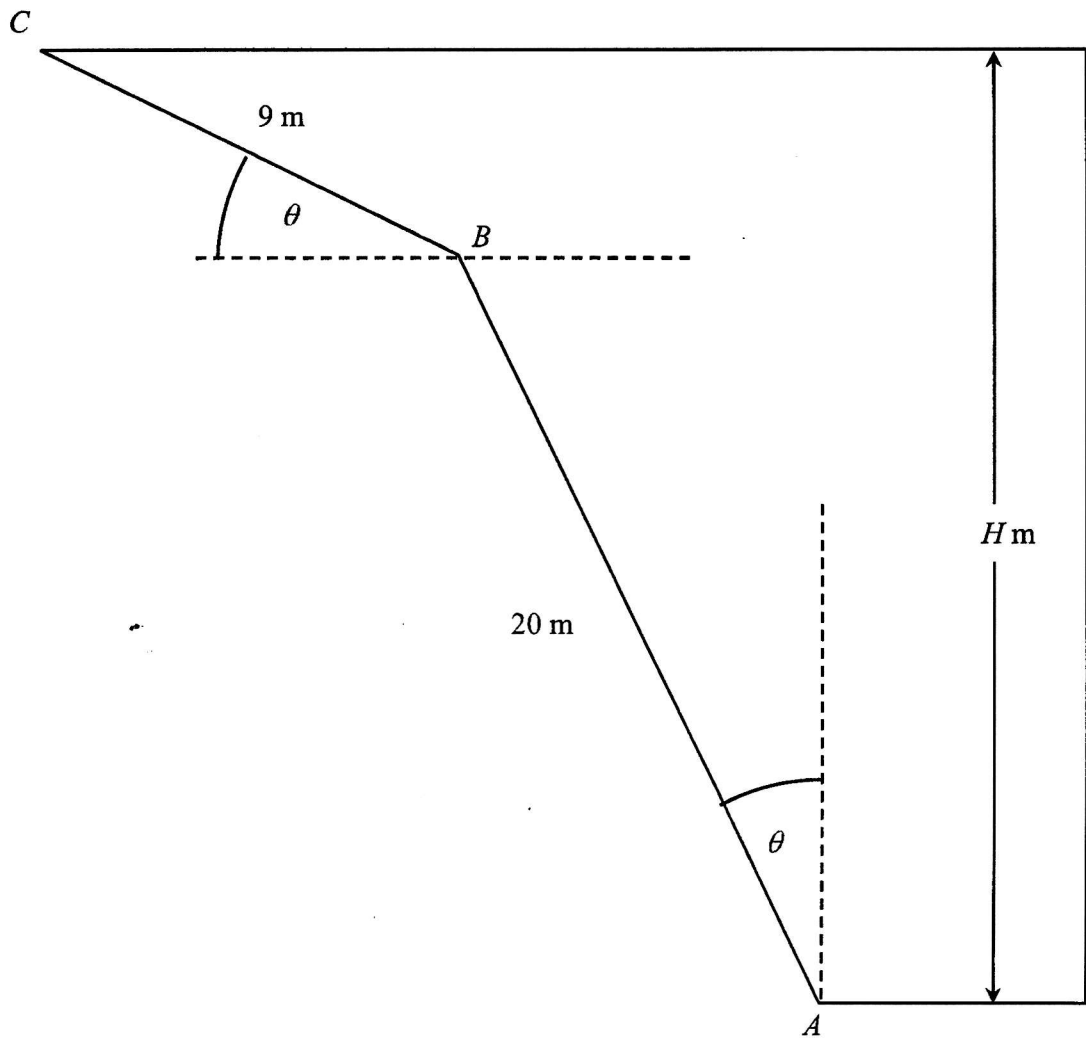

(i) Show that  $H = 20 \cos \theta + 9 \sin \theta$ .

[2]

12 (ii) Express  $H$  in the form  $R \sin(\theta + \alpha)$ , where  $R > 0$  and  $0^\circ < \alpha < 90^\circ$ . [4]

(iii) Find the greatest possible value of  $H$  and the value of  $\theta$  at which this occurs. [3]

13 The gradient function of a curve  $y$  is given by  $2x^2 + x - 6$ .

[6]

Given that  $y$  has a minimum value of  $1\frac{3}{8}$ , find the equation of the curve.

End of Paper

Answer Key

|     |                                                                                                                                                       |       |                                                                                              |
|-----|-------------------------------------------------------------------------------------------------------------------------------------------------------|-------|----------------------------------------------------------------------------------------------|
| 1i  | $-2x \sin 2x + \cos 2x$                                                                                                                               | 7i    | $A(0, 1), B(0, \frac{17}{8})$                                                                |
| 1ii | $-\frac{\pi}{2}$                                                                                                                                      | 7ii   | $1\frac{5}{16}$ or 1.3125 units <sup>2</sup>                                                 |
| 2i  | $4 + \frac{2}{x} - \frac{1}{x^2} - \frac{1}{x+1}$                                                                                                     | 8ii   | $(x-2)^2 + (y-8)^2 = 100$                                                                    |
| 2ii | $4x + 2 \ln x + \frac{1}{x} - \ln(x+1) + c$                                                                                                           | 8iii  | $y = 18$<br>$y = -2$                                                                         |
| 3i  | $112^x = \frac{343}{64}$                                                                                                                              | 9i    | $(-\frac{1}{4}, \frac{1}{2\sqrt{e}})$                                                        |
| 3ii | 0.36                                                                                                                                                  | 9ii   | Minimum point                                                                                |
| 4i  | $x < \frac{1}{2}$ or $x > 2$                                                                                                                          | 10i   | $Y = \lg y, X = \lg(1+x)$                                                                    |
| 4ii | $p < -2$ and $p < -5$ or $p > 4$<br>$\therefore p < -5$                                                                                               | 10ii  | $h = 10^{\text{vertical intercept}}$ or<br>$h = e^{\text{vertical intercept}}$               |
| 5   | $x = 8$ or $x = 16$                                                                                                                                   | 11ii  | Abnormal reading (4, 3.71)<br>Estimated value of $y^2 = 13$<br>Estimated value of $y = 3.61$ |
| 6i  | $(x-4)(x^2 + 10x + 52)$                                                                                                                               | 11iii | $a = -0.551, b = 1.1$                                                                        |
| 6ii | $x = 4$ or $x = \frac{-9 \pm \sqrt{9^2 - 4(1)(56)}}{2(1)}$<br>$x = \frac{-9 \pm \sqrt{-143}}{2}$ (no soln)<br>Therefore, there is only one real root. | 12ii  | $H = \sqrt{481} \sin(\theta + 65.8^\circ)$                                                   |
|     |                                                                                                                                                       | 12iii | Greatest value = $\sqrt{481}$ or 21.9<br>$\theta = 24.2^\circ$                               |
|     |                                                                                                                                                       | 13    | $y = \frac{2x^3}{3} + \frac{x^2}{2} - 6x + 7$                                                |

the name of the

of the name of the

the name of the

of the name of the