

*Visit*

**FREETESTPAPER.com**

*for more papers*



Website: [freetestpaper.com](http://www.freetestpaper.com)



[Facebook.com/freetestpaper](https://www.facebook.com/freetestpaper)



[Twitter.com/freetestpaper](https://www.twitter.com/freetestpaper)

Name:	Index No.:	Class:
-------	------------	--------

## PRESBYTERIAN HIGH SCHOOL



### ADDITIONAL MATHEMATICS Paper 1

**4049/01**

19 August 2024

Monday

2 hours 15 min

*PRESBYTERIAN HIGH SCHOOL PRESBYTERIAN HIGH SCHOOL PRESBYTERIAN HIGH SCHOOL PRESBYTERIAN HIGH SCHOOL  
 PRESBYTERIAN HIGH SCHOOL PRESBYTERIAN HIGH SCHOOL PRESBYTERIAN HIGH SCHOOL PRESBYTERIAN HIGH SCHOOL  
 PRESBYTERIAN HIGH SCHOOL PRESBYTERIAN HIGH SCHOOL PRESBYTERIAN HIGH SCHOOL PRESBYTERIAN HIGH SCHOOL  
 PRESBYTERIAN HIGH SCHOOL PRESBYTERIAN HIGH SCHOOL PRESBYTERIAN HIGH SCHOOL PRESBYTERIAN HIGH SCHOOL  
 PRESBYTERIAN HIGH SCHOOL PRESBYTERIAN HIGH SCHOOL PRESBYTERIAN HIGH SCHOOL PRESBYTERIAN HIGH SCHOOL*

### 2024 SECONDARY FOUR EXPRESS / FIVE NORMAL (ACADEMIC) PRELIMINARY EXAMINATIONS

**DO NOT OPEN THIS QUESTION PAPER UNTIL YOU ARE TOLD TO DO SO.**

**INSTRUCTIONS TO CANDIDATES**

Write your name, index number and class in the spaces provided above.

Write in dark blue or black pen.

You may use an HB pencil for any diagrams or graphs.

Do not use staples, paper clips, glue or correction fluid.

Answer all the questions.

Write your answers in the spaces provided below the questions.

Give non-exact numerical answers correct to 3 significant figures or 1 decimal place in the case of angles in degrees, unless a different level of accuracy is specified in the question.

The use of an approved scientific calculator is expected, where appropriate.

You are reminded of the need for clear presentation in your answers.

The number of marks is given in brackets [ ] at the end of each question or part question.

The total number of marks for this paper is 90.

<i>For Examiner's Use</i>													
Qn	1	2	3	4	5	6	7	8	9	10	11	12	Marks Deducted
Marks													
<b>Category</b>	Accuracy		Units		Notations		Others						
<b>Question No.</b>													

<b>TOTAL MARKS</b>
90

This question paper consists of **19** printed pages and **1** blank page.

**Mathematical Formulae****1. ALGEBRA***Quadratic Equation*

For the equation  $ax^2 + bx + c = 0$ ,

$$x = \frac{-b \pm \sqrt{b^2 - 4ac}}{2a}$$

*Binomial expansion*

$$(a+b)^n = a^n + \binom{n}{1}a^{n-1}b + \binom{n}{2}a^{n-2}b^2 + \dots + \binom{n}{r}a^{n-r}b^r + \dots + b^n,$$

where  $n$  is a positive integer and  $\binom{n}{r} = \frac{n!}{(n-r)!r!} = \frac{n(n-1)\dots(n-r+1)}{r!}$

**2. TRIGONOMETRY***Identities*

$$\sin^2 A + \cos^2 A = 1$$

$$\sec^2 A = 1 + \tan^2 A$$

$$\operatorname{cosec}^2 A = 1 + \cot^2 A$$

$$\sin(A \pm B) = \sin A \cos B \pm \cos A \sin B$$

$$\cos(A \pm B) = \cos A \cos B \mp \sin A \sin B$$

$$\tan(A \pm B) = \frac{\tan A \pm \tan B}{1 \mp \tan A \tan B}$$

$$\sin 2A = 2 \sin A \cos A$$

$$\cos 2A = \cos^2 A - \sin^2 A = 2 \cos^2 A - 1 = 1 - 2 \sin^2 A$$

$$\tan 2A = \frac{2 \tan A}{1 - \tan^2 A}$$

*Formulae for  $\triangle ABC$* 

$$\frac{a}{\sin A} = \frac{b}{\sin B} = \frac{c}{\sin C}$$

$$a^2 = b^2 + c^2 - 2bc \cos A$$

$$\Delta = \frac{1}{2}bc \sin A$$

1 Express  $\frac{3x^2 + 14x + 6}{x^2(x + 3)}$  as the sum of 3 partial fractions.

[5]

2 (a) State, in terms of  $\pi$ ,

(i) the principal value of  $\tan^{-1}(-\sqrt{3})$ , [1]

(ii) the values between which the principal value of  $\sin^{-1}x$  must lie. [1]

(b) Given that  $A$  is a reflex angle and  $\cos A = -\frac{4}{5}$ , find the exact value of  $\cos(A + 30^\circ)$

without the use of a calculator. [3]

- 3 (a) Find the set of values of the constant  $k$  for which the curve  $y = -kx^2 - 2x + 2k - 3$  does not intersect the  $x$ -axis. [3]

- (b) Using the answer in **part (a)**, explain whether it is possible for  $-kx^2 - 2x + 2k - 3$  to be positive for all  $x$ . [2]

- 4 A roller coaster is being designed such that the height,  $h$  m, of a rider above the ground in a section of the roller coaster ride is given by  $h = 10x - 2x^2 - 4$ , where  $x$  is the horizontal distance of the rider from the starting point and  $1 \leq x \leq 4$ .

(a) Express  $h$  in the form  $a + b(x + c)^2$  where  $a$ ,  $b$  and  $c$  are constants to be determined. [3]

(b) Hence, explain why the rider cannot reach a height of 10 m. [1]

(c) After testing the prototype, the roller coaster designer wants to make the ride more exciting by moving the highest point of this section of the roller coaster ride up by 0.2 m and left by 0.1 m. Write down a possible new expression for  $h$ . [1]

- 5 Water is poured into an empty inverted conical container with radius 6 cm and slant height 10 cm. After  $t$  seconds, the radius of the top surface of the water is  $r$  cm.

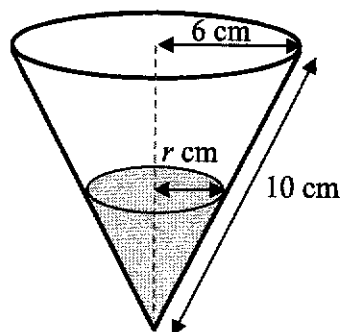

- (a) Show that the surface area,  $S$ , of water in contact with the container at any time is given by

$$S = \frac{5}{3}\pi r^2.$$

[The curved surface area of a cone of base radius  $r$  and slant height  $l$  is  $\pi rl$ .] [2]

- (b) Water is poured into the container such that  $r$  increases at a constant rate. Given that it takes 30 seconds to completely fill up the empty container, write down the rate at which  $r$  increases. [1]

- (c) Hence calculate the rate at which  $S$  increases when the container is one-eighth filled. [4]

6 A curve has equation  $y = \frac{30(2x-1)^3}{e^{3x}}$ , where  $x > 0$ .

(a) Find the  $x$ -coordinates of the stationary points of the curve.

[5]

(b) Determine the nature of each of the stationary points.

[3]

(c) Using your answer in **part (b)**, infer and write down the set of values of  $x$  for which  $y$  is an increasing function.

[2]

- 7 The diagram shows part of the curve  $y = \frac{40}{x+8} - 20$ , where  $x > -8$ . The curve intersects the  $x$ -axis and  $y$ -axis at  $P$  and  $Q$  respectively. The tangent to the curve at  $R$  is parallel to line  $PQ$ .

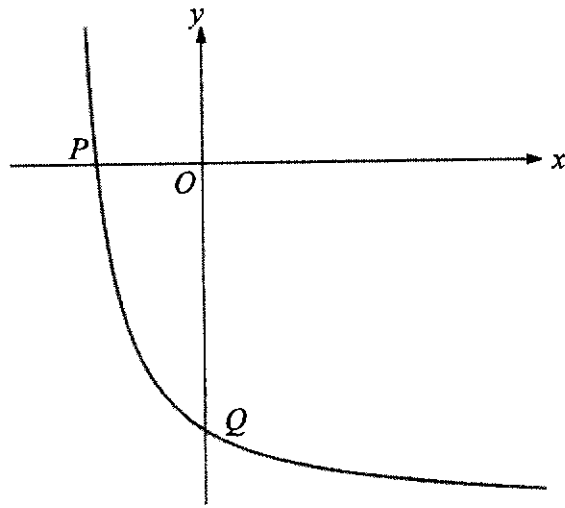

- (a) Show that the coordinates of point  $R$  are  $(-4, -10)$ .

[5]

- (b) Given that the point  $S$  has coordinates  $(-2, -5)$ , find the area of the quadrilateral  $PRQS$ . [2]
- (c) Determine, with reason, whether  $PRQS$  is a parallelogram. [3]

- 8 The diagram shows part of the curve  $y = \frac{30}{2x-1}$  and the line  $y = -\frac{4}{3}x + \frac{38}{3}$ . The curve intersects the line at the points  $A$  and  $B$ .

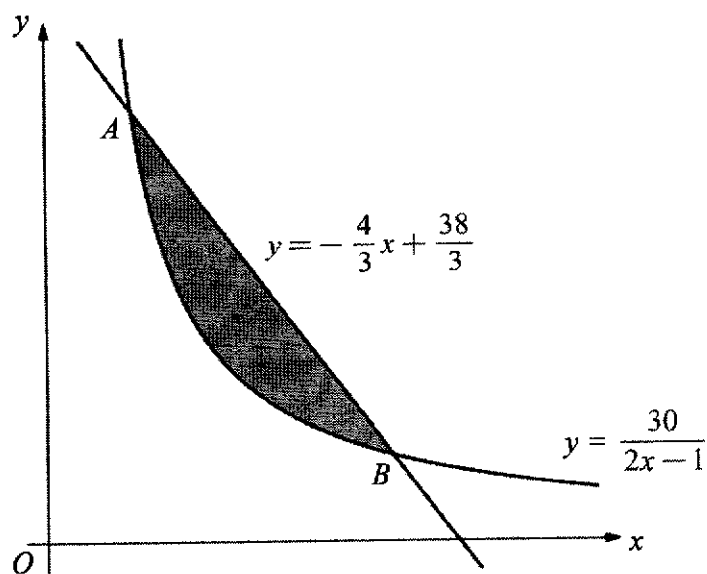

- (a) Find the coordinates of the points  $A$  and  $B$ .

[3]

(b) Find the area of the shaded region.

[4]

(c) Show that the area bounded by the curve, the  $y$ -axis and the lines  $y = 2$  and  $y = 6$  can be expressed in the form  $15 \ln p + q$ , where  $p$  and  $q$  are constants to be determined.

[3]

9 The function  $f$  is given by  $f(x) = x^3 - x^2 + ax - 1$ .

It is given that  $\frac{f(x)}{x-1} = Q(x) + \frac{3}{x-1}$ , where  $Q(x)$  is a quadratic function.

(a) Explain how you can use Remainder Theorem to show that  $a = 4$ .

[3]

(b) By using long division, divide  $f(x)$  by  $x^2 + 1$ .

Hence, express  $\frac{f(x)}{x^2 + 1}$  in the form  $px + q + \frac{rx}{x^2 + 1}$ , where  $p$ ,  $q$  and  $r$  are constants to be determined.

[2]

(c) Find  $\frac{d}{dx} \ln(x^2 + 1)$ .

[1]

(d) Hence, using your results from **part (b) and (c)**, find  $\int \frac{f(x)}{x^2 + 1} dx$ .

[2]

10 The equation of a circle,  $C_1$ , with centre  $A$ , is  $x^2 + y^2 - 6x + 8y - 75 = 0$ .

(a) Find the radius of the circle and the coordinates of its centre,  $A$ .

[4]

(b) A second circle,  $C_2$ , with centre  $B$ , has radius 12 units.

The equation of the perpendicular bisector of  $AB$  is  $y = -\frac{1}{2}x + 5$ .

Find the equation of the second circle,  $C_2$ .

[5]

- (c)  $P$  is a point on the perpendicular bisector of  $AB$ , where  $P$  is **not** the midpoint of  $A$  and  $B$ .  
Explain whether triangle  $PAB$  is an isosceles triangle. [1]

11 (a) Sketch the graph of  $y = e^{-x}$  on the given axes. Label any axial intercepts.

[1]

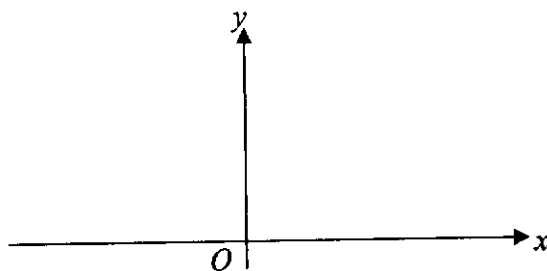

(b) The curve  $y = f(x)$  is such that  $f'(x) = e^{2x+1} + e^{-x}$ .

(i) Explain why the curve has no stationary points.

[2]

(ii) The curve passes through the point  $(\ln 4, 8e)$ . Without the use of a calculator, find an expression for  $f(x)$ . Show all working clearly.

[6]

- 12 The diagram shows the graph of  $y = f'(x)$ .

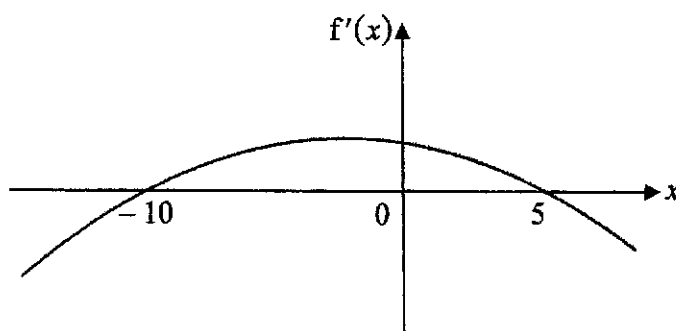

- (a) Write down the range of values of  $x$  for which the **function**  $f$  decreases as  $x$  increases. [1]
- (b) The above function  $f$  is given by  $f(x) = 12k^2x - 2x^3 - 3kx^2$ , where  $k$  is a positive constant. By solving a suitable inequality, use the answer in **part (a)** to find the value of the constant  $k$ . [4]
- (c) Explain how you can use the above graph of  $y = f'(x)$  to determine the value of  $x$  for which  $f(x)$  is a maximum value. [1]

**END OF PAPER**



Name:	Index No.:	Class:
-------	------------	--------

## PRESBYTERIAN HIGH SCHOOL



**ADDITIONAL MATHEMATICS  
Paper 1**

**4049/01**

19 August 2024

Monday

2 hours 15 min

*PRESBYTERIAN HIGH SCHOOL PRESBYTERIAN HIGH SCHOOL PRESBYTERIAN HIGH SCHOOL PRESBYTERIAN HIGH SCHOOL  
PRESBYTERIAN HIGH SCHOOL PRESBYTERIAN HIGH SCHOOL PRESBYTERIAN HIGH SCHOOL PRESBYTERIAN HIGH SCHOOL  
PRESBYTERIAN HIGH SCHOOL PRESBYTERIAN HIGH SCHOOL PRESBYTERIAN HIGH SCHOOL PRESBYTERIAN HIGH SCHOOL  
PRESBYTERIAN HIGH SCHOOL PRESBYTERIAN HIGH SCHOOL PRESBYTERIAN HIGH SCHOOL PRESBYTERIAN HIGH SCHOOL  
PRESBYTERIAN HIGH SCHOOL PRESBYTERIAN HIGH SCHOOL PRESBYTERIAN HIGH SCHOOL PRESBYTERIAN HIGH SCHOOL*

**2024 SECONDARY FOUR EXPRESS / FIVE NORMAL (ACADEMIC)  
PRELIMINARY EXAMINATIONS**

# MARKING SCHEME

**Mathematical Formulae****1. ALGEBRA***Quadratic Equation*

For the equation  $ax^2 + bx + c = 0$ ,

$$x = \frac{-b \pm \sqrt{b^2 - 4ac}}{2a}$$

*Binomial expansion*

$$(a+b)^n = a^n + \binom{n}{1}a^{n-1}b + \binom{n}{2}a^{n-2}b^2 + \dots + \binom{n}{r}a^{n-r}b^r + \dots + b^n,$$

where  $n$  is a positive integer and  $\binom{n}{r} = \frac{n!}{(n-r)!r!} = \frac{n(n-1)\dots(n-r+1)}{r!}$

**2. TRIGONOMETRY***Identities*

$$\sin^2 A + \cos^2 A = 1$$

$$\sec^2 A = 1 + \tan^2 A$$

$$\operatorname{cosec}^2 A = 1 + \cot^2 A$$

$$\sin(A \pm B) = \sin A \cos B \pm \cos A \sin B$$

$$\cos(A \pm B) = \cos A \cos B \mp \sin A \sin B$$

$$\tan(A \pm B) = \frac{\tan A \pm \tan B}{1 \mp \tan A \tan B}$$

$$\sin 2A = 2 \sin A \cos A$$

$$\cos 2A = \cos^2 A - \sin^2 A = 2 \cos^2 A - 1 = 1 - 2 \sin^2 A$$

$$\tan 2A = \frac{2 \tan A}{1 - \tan^2 A}$$

*Formulae for  $\triangle ABC$* 

$$\frac{a}{\sin A} = \frac{b}{\sin B} = \frac{c}{\sin C}$$

$$a^2 = b^2 + c^2 - 2bc \cos A$$

$$\Delta = \frac{1}{2}bc \sin A$$

- 1 Express  $\frac{3x^2 + 14x + 6}{x^2(x+3)}$  as the sum of 3 partial fractions. [5]

$$\frac{3x^2 + 14x + 6}{x^2(x+3)} = \frac{A}{x} + \frac{B}{x^2} + \frac{C}{x+3} \quad \left[ \text{M1, accept } \frac{Ax+B}{x^2} + \frac{C}{x+3} \right]$$

$$3x^2 + 14x + 6 = Ax(x+3) + B(x+3) + Cx^2 \quad [\text{M1 for comparing numerator}]$$

$$\text{Subst. } x=0: 6 = 3B \quad \left[ \text{M1 correct method of subst. or compare coeff.} \right]$$

$$B = 2$$

$$\text{Subst. } x = -3: -9 = 9C$$

$$C = -1$$

$$\text{Subst. } x=1: 23 = 4A + 7$$

$$A = 4$$

$$\text{Therefore, } \frac{3x^2 + 14x + 6}{x^3 + 3x^2} = \frac{4}{x} + \frac{2}{x^2} - \frac{1}{x+3} \quad [\text{A1 for 2 correct terms; A2 for all correct}]$$

- 2 (a) State, in terms of  $\pi$ ,
- (i) the principal value of  $\tan^{-1}(-\sqrt{3})$ , [1]
- (ii) the values between which the principal value of  $\sin^{-1}x$  must lie. [1]
- (b) Given that  $A$  is a reflex angle and  $\cos A = -\frac{4}{5}$ , find the exact value of  $\cos(A + 30^\circ)$  without the use of a calculator. [3]

(a) (i)  $-\frac{\pi}{3}$  [B1]

(ii)  $-\frac{\pi}{2} \leq \sin^{-1}x \leq \frac{\pi}{2}$  [B1]

- (b)  $A$  lies in the 3<sup>rd</sup> quadrant.

$$\sin A = -\frac{3}{5} \quad [\text{B1}]$$

$$\cos(A + 30^\circ) = \cos A \cos 30^\circ - \sin A \sin 30^\circ$$

$$= \left(-\frac{4}{5}\right)\left(\frac{\sqrt{3}}{2}\right) - \left(-\frac{3}{5}\right)\left(\frac{1}{2}\right) \quad \left[ \text{M1 for } \cos 30^\circ = \frac{\sqrt{3}}{2} \text{ or } \sin 30^\circ = \frac{1}{2} \right]$$

$$= \frac{3}{10} - \frac{2}{5}\sqrt{3} \quad [\text{A1}]$$

- 3 (a) Find the set of values of the constant  $k$  for which the curve  $y = -kx^2 - 2x + 2k - 3$  does not intersect the  $x$ -axis. [3]

$$b^2 - 4ac < 0$$

$$(-2)^2 - 4(-k)(2k - 3) < 0 \quad \left[ \begin{array}{l} \text{M1 for } b^2 - 4ac < 0 \text{ and} \\ \text{at least 2 correct substitution of a, b, c} \end{array} \right]$$

$$4 + 8k^2 - 12k < 0$$

$$2k^2 - 3k + 1 < 0$$

$$(2k - 1)(k - 1) < 0 \quad [\text{M1 for factorisation/finding } x - \text{intercepts}]$$

$$\frac{1}{2} < k < 1 \quad [\text{A1}]$$

- (b) Using the answer in part (a), explain whether it is possible for  $-kx^2 - 2x + 2k - 3$  to be positive for all  $x$ . [2]

Since  $\frac{1}{2} < k < 1$ , coefficient of  $x^2 = -k < 0$ . [M1]

The curve lies entirely below the axis, therefore it is **not possible** for  $-kx^2 - 2x + 2k - 3$  to be positive for all  $x$ . [A1]

- 4 A roller coaster is being designed such that the height,  $h$  m, of a rider above the ground in a section of the roller coaster ride is given by  $h = 10x - 2x^2 - 4$ , where  $x$  is the horizontal distance of the rider from the starting point and  $1 \leq x \leq 4$ .

- (a) Express  $h$  in the form  $a + b(x + c)^2$  where  $a$ ,  $b$  and  $c$  are constants to be determined. [3]

$$\begin{aligned}
 h &= 10x - 2x^2 - 4 \\
 &= -2(x^2 - 5x + 2) && \text{[M1 factorise]} \\
 &= -2\left[\left(x - \frac{5}{2}\right)^2 - \left(\frac{5}{2}\right)^2 + 2\right] \\
 &= 8.5 - 2\left(x - \frac{5}{2}\right)^2 && \text{[B1, B1 for each term]}
 \end{aligned}$$

- (b) Hence, explain why the rider cannot reach a height of 10 m. [1]

Since the maximum value of the rider is 8.5 m and  $8.5 < 10$ , the rider cannot reach a height of 10 m. [B1]

- (c) After testing the prototype, the roller coaster designer wants to make the ride more exciting by moving the highest point of this section of the roller coaster ride up by 0.2 m and left by 0.1 m. Write down a possible new expression for  $h$ . [1]

$$h = 9.7 - 2(x - 2.4)^2 \quad \text{[B1]}$$

- 5 Water is poured into an empty inverted conical container with radius 6 cm and slant height 10 cm. After  $t$  seconds, the radius of the top surface of the water is  $r$  cm.

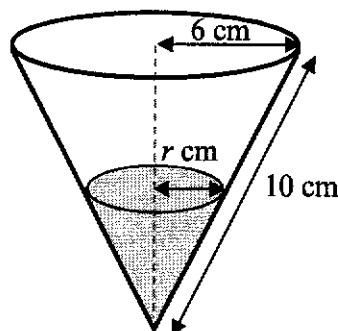

- (a) Show that the surface area,  $S$ , of water in contact with the container at any time is given by

$$S = \frac{5}{3}\pi r^2. \quad [2]$$

By similar triangles,  $\frac{l}{10} = \frac{r}{6}$

$$l = \frac{5}{3}r \quad [\text{M1}]$$

$$S = \pi(r) \left(\frac{5}{3}r\right) = \frac{5}{3}\pi r^2 \quad [\text{A1}]$$

- (b) Water is poured into the container such that  $r$  increases at a constant rate. Given that it takes 30 seconds to completely fill up the empty container, write down the rate at which  $r$  increases. [1]

$$\frac{dr}{dt} = \frac{6}{30} = \frac{1}{5} \text{ cm/s} \quad [\text{B1}]$$

- (c) Hence calculate the rate at which  $S$  increases when the container is one-eighth filled. [4]

$$\frac{dS}{dt} = \frac{dS}{dr} \times \frac{dr}{dt} \quad [\text{M1 for chain rule}]$$

$$= \frac{10}{3}\pi r \times \frac{1}{5} \quad [\text{B1 for } \frac{10}{3}\pi r]$$

When the container is one-eighth filled,

$$\left(\frac{r}{6}\right)^3 = \frac{1}{8}$$

$$r = \frac{1}{2} \times 6 = 3 \quad [\text{B1 for } r = 3]$$

$$\text{When } r = 3, \frac{dS}{dt} = \frac{2}{3}\pi(3) = 2\pi \quad (\text{or } 6.28 \text{ cm/s to 3 s.f.}) \quad [\text{A1}]$$

6 A curve has equation  $y = \frac{30(2x-1)^3}{e^{3x}}$ , where  $x > 0$ .

(a) Find the  $x$ -coordinates of the stationary points of the curve. [5]

$$\frac{dy}{dx} = \frac{e^{3x} \cdot 30(3)(2x-1)^2(2) - 30(2x-1)^3 \cdot 3e^{3x}}{e^{6x}}$$

[ M1 for chain rule  
i.e.  $3(2x-1)^2(2)$  or  $3e^{3x}$  seen  
M1 for correct use of quotient  
rule even w/o chain rule ]

$$= \frac{90e^{3x}(2x-1)^2(2-2x+1)}{e^{6x}}$$

$$= \frac{90(2x-1)^2(3-2x)}{e^{3x}} \quad \text{[M1 factorising]}$$

At stationary point,  $\frac{dy}{dx} = 0$

$$(2x-1)^2 = 0 \quad \text{or} \quad 3-2x = 0 \quad \text{[M1]}$$

$$x = \frac{1}{2} \quad \text{or} \quad x = \frac{3}{2} \quad \text{[A1]}$$

(b) Determine the nature of each of the stationary points. [3]

$x$	$\left(\frac{1}{2}\right)^-$	$\frac{1}{2}$	$\left(\frac{1}{2}\right)^+$
$\frac{dy}{dx}$	+	0	+
	/	—	/

$x$	$\left(\frac{3}{2}\right)^-$	$\frac{3}{2}$	$\left(\frac{3}{2}\right)^+$
$\frac{dy}{dx}$	+	0	-
	/	—	\

[M1 for first derivative test]

Therefore, the stationary point at  $x = \frac{1}{2}$  is a **point of inflexion** and the stationary

point at  $x = \frac{3}{2}$  is a **maximum point**. [A1, A1]

(c) Using your answer in part (b), infer and write down the set of values of  $x$  for which  $y$  is an increasing function. [2]

$$0 < x < \frac{3}{2}, x \neq \frac{1}{2} \quad \text{[B1,B1]} \quad \text{OR} \quad 0 < x < \frac{1}{2}, \frac{1}{2} < x < \frac{3}{2} \quad \text{[B1,B1]}$$

- 7 The diagram shows part of the curve  $y = \frac{40}{x+8} - 20$ , where  $x > -8$ . The curve intersects the  $x$ -axis and  $y$ -axis at  $P$  and  $Q$  respectively. The tangent to the curve at  $R$  is parallel to line  $PQ$ .

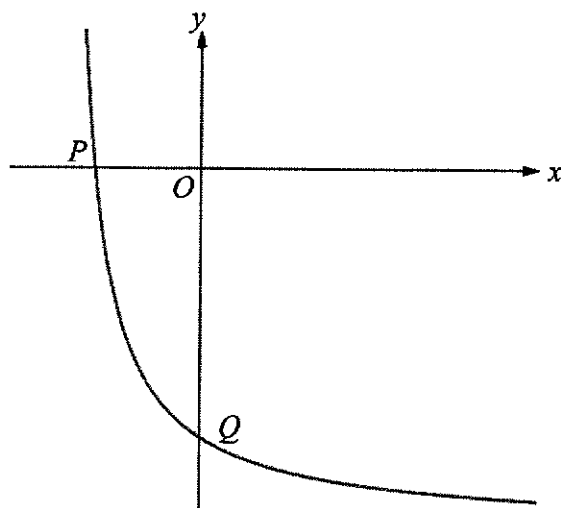

- (a) Show that the coordinates of point  $R$  are  $(-4, -10)$ .

[5]

When  $x = 0$ ,  $y = -15$ .

When  $y = 0$ ,  $x = -6$

[B1 for either coordinates of  $P$  and  $Q$ ]

$$m_{PQ} = \frac{0 - (-15)}{-6 - 0} = -\frac{5}{2} \quad [\text{M1}]$$

$$\frac{dy}{dx} = -\frac{40}{(x+8)^2} \quad [\text{B1}]$$

$$\text{Let } -\frac{40}{(x+8)^2} = -\frac{5}{2}$$

$$(x+8)^2 = 16$$

$$x+8 = \pm 4$$

$$x = -12 \text{ (reject) or } -4 \quad [\text{A1 for } -12 \text{ and not choosing it}]$$

When  $x = -4$ ,  $y = -10$ . Therefore  $R(-4, -10)$ . [A1]

- (b) Given that the point  $S$  has coordinates  $(-2, -5)$ , find the area of the quadrilateral  $PRQS$ . [2]

$$\text{Area} = \frac{1}{2} \begin{vmatrix} -6 & -4 & 0 & -2 & -6 \\ 0 & -10 & -15 & -5 & 0 \end{vmatrix} \quad [\text{M1}]$$

$$= \frac{1}{2} (60 + 60 - 30 - 30)$$

$$= 30 \text{ units}^2 \quad [\text{A1}]$$

- (c) Determine, with reason, whether  $PRQS$  is a parallelogram. [3]

$$m_{PR} = \frac{0 - (-10)}{-6 - (-4)} = -5$$

$$m_{QS} = \frac{-15 - (-5)}{0 - (-2)} = -5$$

$$m_{RQ} = \frac{-10 - (-15)}{-4 - 0} = -\frac{5}{4}$$

$$m_{PS} = \frac{0 - (-5)}{-6 - (-2)} = -\frac{5}{4}$$

[ M1 for 1 pair of gradient ]  
[ M2 for 2 pairs of gradient ]

Since  $m_{PR} = m_{QS}$  and  $m_{RQ} = m_{PS}$ ,  $PRQS$  is a parallelogram [A1]

OR

$$\text{Midpoint of } PQ = \left( \frac{-6 + 0}{2}, \frac{0 - 15}{2} \right) = (-3, -7.5) \quad [\text{M1}]$$

$$\text{Midpoint of } RS = \left( \frac{-4 - 2}{2}, \frac{-10 - 5}{2} \right) = (-3, -7.5) \quad [\text{M1}]$$

Since the diagonals bisect each other,  $PRQS$  is a parallelogram. [A1]

- 8 The diagram shows part of the curve  $y = \frac{30}{2x-1}$  and the line  $y = -\frac{4}{3}x + \frac{38}{3}$ . The curve intersects the line at the points  $A$  and  $B$ .

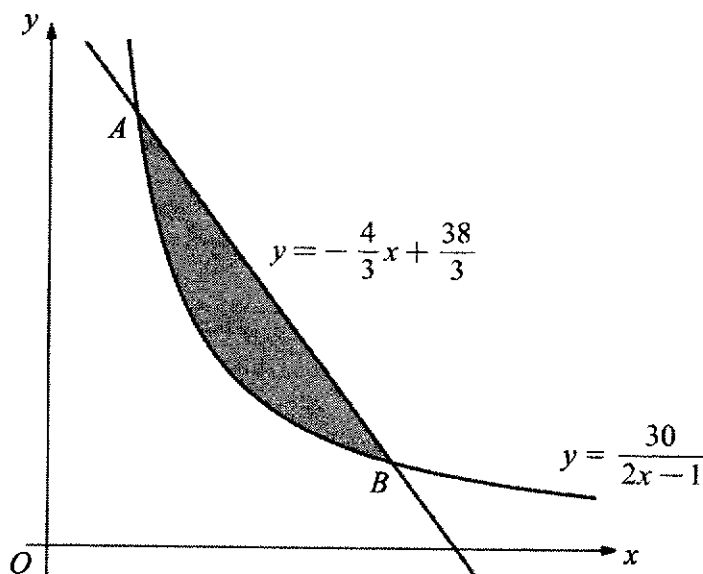

- (a) Find the coordinates of the points  $A$  and  $B$ .

[3]

$$\frac{30}{2x-1} = -\frac{4}{3}x + \frac{38}{3}$$

$$90 = (-4x + 38)(2x - 1)$$

[M1 simplify to quad func]

$$90 = -8x^2 + 4x + 76x - 38$$

$$0 = 8x^2 - 80x + 128$$

$$0 = x^2 - 10x + 16$$

$$0 = (x - 8)(x - 2)$$

$$x = 8 \text{ or } x = 2$$

[A1]

Therefore  $A(2, 10)$  and  $B(8, 2)$ .

[A1]

(b) Find the area of the shaded region.

[4]

$$\begin{aligned}
 \text{Area} &= \int_2^8 -\frac{4}{3}x + \frac{38}{3} - \frac{30}{2x-1} dx && \text{[M1 for correct order of subtraction]} \\
 &= \left[ -\frac{2}{3}x^2 + \frac{38}{3}x - 15\ln(2x-1) \right]_2^8 && \begin{array}{l} \text{[B1 for 2 terms;} \\ \text{[B1 for 3rd term]} \end{array} \\
 &= 58\frac{2}{3} - 15\ln 15 - \left( 22\frac{2}{3} - 15\ln 3 \right) \\
 &= 36 + 15\ln 3 - 15\ln 15 \\
 &= 36 - 15\ln 5 \\
 &= 11.9 \text{ units}^2 \text{ (to 3 s.f.)} && \text{[A1]}
 \end{aligned}$$

OR

$$\begin{aligned}
 \text{Area} &= \frac{1}{2}(10+2)(6) - \int_2^8 \frac{30}{2x-1} dx && \text{[M1 for correct integral and subtraction]} \\
 &= 36 - [15\ln(2x-1)]_2^8 && \begin{array}{l} \text{[B1 for 36;} \\ \text{[B1 for integrated term]} \end{array} \\
 &= 36 - (15\ln 15 - 15\ln 3) \\
 &= 11.9 \text{ units}^2 \text{ (to 3 s.f.)} && \text{[A1]}
 \end{aligned}$$

(c) Show that the area bounded by the curve, the  $y$ -axis and the lines  $y=2$  and  $y=6$  can be expressed in the form  $15\ln p + q$ , where  $p$  and  $q$  are constants to be determined. [3]

$$\begin{aligned}
 y &= \frac{30}{2x-1} \\
 2x-1 &= \frac{30}{y} \\
 x &= \frac{1}{2} \left( \frac{30}{y} + 1 \right) \\
 &= \frac{15}{y} + \frac{1}{2} \\
 \text{Area} &= \int_2^6 \frac{15}{y} + \frac{1}{2} dy && \text{[M1 for making } x \text{ the subject to form integral]} \\
 &= \left[ 15\ln y + \frac{y}{2} \right]_2^6 && \text{[M1 for correct integration]} \\
 &= 15\ln 3 + 2 && \text{[A1]}
 \end{aligned}$$

9 The function  $f$  is given by  $f(x) = x^3 - x^2 + ax - 1$ .

It is given that  $\frac{f(x)}{x-1} = Q(x) + \frac{3}{x-1}$ , where  $Q(x)$  is a quadratic function.

(a) Explain how you can use Remainder Theorem to show that  $a = 4$ . [3]

Since the **remainder is 3** when  $f(x)$  is divided by  $x - 1$ , [B1]

we let  $f(1) = 3$  [M1 for f(1)]

$$1 - 1 + a - 1 = 3$$

$$a = 4 \text{ (shown)} \quad \text{[A1]}$$

(b) By long division, divide  $f(x)$  by  $x^2 + 1$ .

Hence, express  $\frac{f(x)}{x^2 + 1}$  in the form  $px + q + \frac{rx}{x^2 + 1}$ , where  $p$ ,  $q$  and  $r$  are constants to be determined. [2]

$$\begin{array}{r} \phantom{x^2 + 1} \overline{) x^3 - x^2 + 4x - 1} \\ \underline{x^3 \phantom{- x^2} + x} \phantom{- 1} \\ \phantom{x^3} - x^2 + 3x - 1 \\ \underline{-x^2 \phantom{+ 3x} - 1} \\ \phantom{x^3} \phantom{- x^2} 3x \phantom{- 1} \end{array} \quad \text{[M1]}$$

$$\frac{f(x)}{x^2 + 1} = x - 1 + \frac{3x}{x^2 + 1} \quad \text{[A1]}$$

(c) Find  $\frac{d}{dx} \ln(x^2 + 1)$ . [1]

$$\frac{d}{dx} \ln(x^2 + 1) = \frac{2x}{x^2 + 1} \quad \text{[B1]}$$

(d) Hence, using your results from part (b) and (c), find  $\int \frac{f(x)}{x^2 + 1} dx$ . [2]

$$\begin{aligned} \int \frac{f(x)}{x^2 + 1} dx &= \int x - 1 + \frac{3x}{x^2 + 1} dx \\ &= \frac{x^2}{2} - x + \frac{3}{2} \ln(x^2 + 1) + c \quad \left[ \begin{array}{l} \text{B1 for ln term, B1 for rest of 3 terms} \\ \text{Allow ECF} \end{array} \right] \end{aligned}$$

10 The equation of a circle,  $C_1$ , with centre  $A$ , is  $x^2 + y^2 - 6x + 8y - 75 = 0$ .

(a) Find the radius of the circle and the coordinates of its centre,  $A$ . [4]

$$(x - 3)^2 + (y + 4)^2 = 10^2 \quad \text{[M1 for } (x - 3)^2 \text{ or } (y + 4)^2 \text{ seen, M1 for } 10^2 \text{]}$$

$$A(3, -4) \text{ and radius} = 10 \text{ units} \quad \text{[A1, A1]}$$

(b) A second circle,  $C_2$ , with centre  $B$ , has radius 12 units.

The equation of the perpendicular bisector of  $AB$  is  $y = -\frac{1}{2}x + 5$ .

Find the equation of the second circle. [5]

$$m_{AB} = 2 \quad \text{[B1]}$$

Equation of  $AB$  is

$$y - (-4) = 2(x - 3)$$

$$y = 2x - 10 \quad \text{[M1]}$$

$$2x - 10 = -\frac{1}{2}x + 5$$

$$\frac{5}{2}x = 15$$

$$x = 6 \quad \text{[M1]}$$

$$y = 2$$

Let centre of second circle be  $(a, b)$

$$\left(\frac{3+a}{2}, \frac{-4+b}{2}\right) = (6, 2) \quad \text{[M1]}$$

$$a = 9, b = 8$$

Therefore, equation of circle is  $(x - 9)^2 + (y - 8)^2 = 144$  [A1]

(c)  $P$  is a point on the perpendicular bisector of  $AB$ , where  $P$  is **not** the midpoint of  $A$  and  $B$ .

Justify whether triangle  $PAB$  is an isosceles triangle. [1]

Since  $P$  is equidistant from  $A$  and  $B$ , i.e.  $PA = PB$ , the triangle is isosceles. [B1]

- 11 (a) Sketch the graph of  $y = e^{-x}$  on the given axes. Label any axial intercepts. [1]

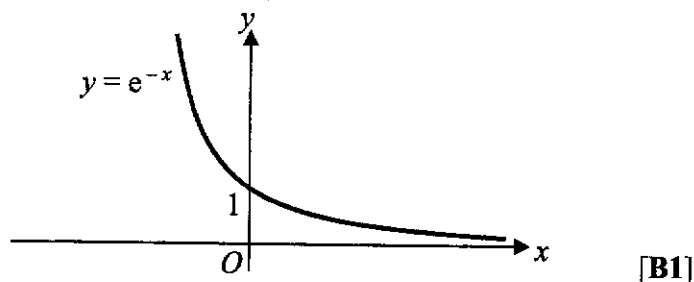

- (b) The curve  $y = f(x)$  is such that  $f'(x) = e^{2x+1} + e^{-x}$ .  
 (i) Explain why the curve has no stationary points. [2]

Since  $e^{2x+1} > 0$  and  $e^{-x} > 0$  for all real values of  $x$ , [B1]  
 $f'(x) \neq 0$ , therefore the curve has no stationary points. [B1]

- (ii) The curve passes through the point  $(\ln 4, 8e)$ . Without the use of a calculator, find an expression for  $f(x)$ . Show all working clearly. [6]

$$f(x) = \frac{e^{2x+1}}{2} - e^{-x} + c \quad [\text{B1 for 2 terms, B1 for 3rd term}]$$

$$8e = \frac{e^{2\ln 4+1}}{2} - e^{-\ln 4} + c$$

$$8e = \frac{e^{\ln 16+1}}{2} - e^{\ln(4)^{-1}} + c \quad \left[ \begin{array}{l} \text{M1 for power law} \\ \text{i.e. either } \ln 16 \text{ or } \ln(4)^{-1} \text{ seen} \end{array} \right]$$

$$8e = \frac{16e}{2} - \frac{1}{4} + c \quad \left[ \text{M1 for } \times e, \text{ M1 for } -\frac{1}{4} \text{ seen} \right]$$

$$c = \frac{1}{4}$$

$$\text{Therefore, } f(x) = \frac{e^{2x+1}}{2} - e^{-x} + \frac{1}{4} \quad [\text{A1}]$$

- 12 The diagram shows the graph of  $y = f'(x)$ .

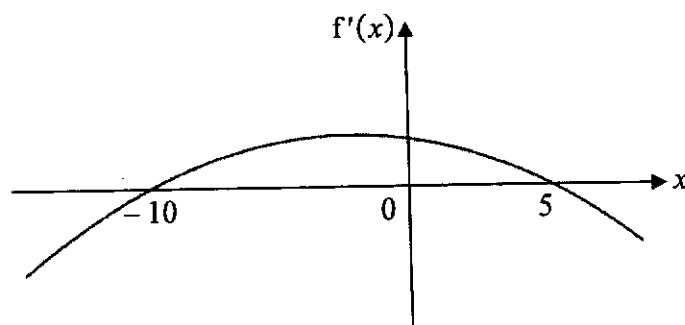

- (a) Write down the range of values of  $x$  for which the **function**  $f$  decreases as  $x$  increases. [1]  
 $x < -10$  or  $x > 5$  [B1]
- (b) The above function  $f$  is given by  $f(x) = 12k^2x - 2x^3 - 3kx^2$ , where  $k$  is a positive constant. By solving a suitable inequality, use the answer in part (a) to find the value of the constant  $k$ . [4]

$$f'(x) = 12k^2 - 6x^2 - 6kx \quad [\text{B1}]$$

For  $f$  to be decreasing,

$$12k^2 - 6x^2 - 6kx < 0$$

$$x^2 + kx - 2k^2 > 0$$

$$(x + 2k)(x - k) > 0 \quad [\text{M1 for correct factorisation or for } f'(x) < 0]$$

$$x < -2k \quad \text{or} \quad x > k \quad [\text{A1}]$$

$$\text{Therefore } k = 5 \quad [\text{A1}]$$

- (c) Explain how you can use the above graph of  $y = f'(x)$  to determine the value of  $x$  for which  $f(x)$  is a maximum value. [1]  
 From the graph,  $f'(x)$  changes from positive to negative at  $x = 5$ , therefore  $f(x)$  is a maximum value when  $x = 5$ . [B1]

**END OF PAPER**

Name:	Index No.:	Class:
-------	------------	--------

## PRESBYTERIAN HIGH SCHOOL



### ADDITIONAL MATHEMATICS Paper 2

**4049/02**

20 August 2024

Tuesday

2 hours 15 min

*PRESBYTERIAN HIGH SCHOOL PRESBYTERIAN HIGH SCHOOL PRESBYTERIAN HIGH SCHOOL PRESBYTERIAN HIGH SCHOOL  
 PRESBYTERIAN HIGH SCHOOL PRESBYTERIAN HIGH SCHOOL PRESBYTERIAN HIGH SCHOOL PRESBYTERIAN HIGH SCHOOL  
 PRESBYTERIAN HIGH SCHOOL PRESBYTERIAN HIGH SCHOOL PRESBYTERIAN HIGH SCHOOL PRESBYTERIAN HIGH SCHOOL  
 PRESBYTERIAN HIGH SCHOOL PRESBYTERIAN HIGH SCHOOL PRESBYTERIAN HIGH SCHOOL PRESBYTERIAN HIGH SCHOOL  
 PRESBYTERIAN HIGH SCHOOL PRESBYTERIAN HIGH SCHOOL PRESBYTERIAN HIGH SCHOOL PRESBYTERIAN HIGH SCHOOL*

### 2024 SECONDARY FOUR EXPRESS / FIVE NORMAL (ACADEMIC) PRELIMINARY EXAMINATIONS

**DO NOT OPEN THIS QUESTION PAPER UNTIL YOU ARE TOLD TO DO SO.**

#### INSTRUCTIONS TO CANDIDATES

- Write your name, index number and class in the spaces provided above.
- Write in dark blue or black pen.
- You may use an HB pencil for any diagrams or graphs.
- Do not use staples, paper clips, glue or correction fluid.

Answer **all** the questions.

Write your answers in the spaces provided below the questions.

Give non-exact numerical answers correct to 3 significant figures or 1 decimal place in the case of angles in degrees, unless a different level of accuracy is specified in the question.

The use of an approved scientific calculator is expected, where appropriate.

You are reminded of the need for clear presentation in your answers.

The number of marks is given in brackets [ ] at the end of each question or part question.

The total number of marks for this paper is 90.

<i>For Examiner's Use</i>											
Qn	1	2	3	4	5	6	7	8	9	10	Marks Deducted
Marks											
Category	Accuracy		Units		Symbols		Others				
Question No.											

<b>TOTAL MARKS</b>
<b>90</b>

This question paper consists of 21 printed pages and 1 blank page.

**Mathematical Formulae****1. ALGEBRA***Quadratic Equation*

For the equation  $ax^2 + bx + c = 0$ ,

$$x = \frac{-b \pm \sqrt{b^2 - 4ac}}{2a}$$

*Binomial expansion*

$$(a+b)^n = a^n + \binom{n}{1} a^{n-1} b + \binom{n}{2} a^{n-2} b^2 + \dots + \binom{n}{r} a^{n-r} b^r + \dots + b^n,$$

where  $n$  is a positive integer and  $\binom{n}{r} = \frac{n!}{(n-r)!r!} = \frac{n(n-1)\dots(n-r+1)}{r!}$

**2. TRIGONOMETRY***Identities*

$$\sin^2 A + \cos^2 A = 1$$

$$\sec^2 A = 1 + \tan^2 A$$

$$\operatorname{cosec}^2 A = 1 + \cot^2 A$$

$$\sin(A \pm B) = \sin A \cos B \pm \cos A \sin B$$

$$\cos(A \pm B) = \cos A \cos B \mp \sin A \sin B$$

$$\tan(A \pm B) = \frac{\tan A \pm \tan B}{1 \mp \tan A \tan B}$$

$$\sin 2A = 2 \sin A \cos A$$

$$\cos 2A = \cos^2 A - \sin^2 A = 2 \cos^2 A - 1 = 1 - 2 \sin^2 A$$

$$\tan 2A = \frac{2 \tan A}{1 - \tan^2 A}$$

*Formulae for  $\triangle ABC$* 

$$\frac{a}{\sin A} = \frac{b}{\sin B} = \frac{c}{\sin C}$$

$$a^2 = b^2 + c^2 - 2bc \cos A$$

$$\Delta = \frac{1}{2} bc \sin A$$

- 1 (a) Write down, and simplify, the first three terms in the expansion of  $\left(3 - \frac{2}{x}\right)^5$  in descending powers of  $x$ . [2]

- (b) Given that there is no term independent of  $x$  in the expansion of  $(5 + ax^2)\left(3 - \frac{2}{x}\right)^5$ , hence find the value of the constant  $a$ . [3]

- 2 In the figure,  $ABCD$  is a rectangle inscribed within a semicircle of radius 4 cm and centre  $O$ . It is given that  $AB = x$  cm and  $BC = y$  cm.

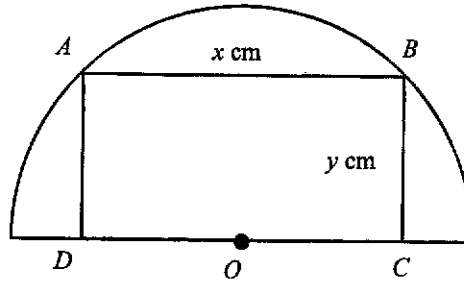

- (a) Show that the area of the rectangle,  $A$  cm, is given by  $A = \frac{1}{2}x\sqrt{64 - x^2}$ . [2]

6

- (b) Find the exact value of  $x$  for which  $A$  has a stationary value.  
Give your answer in the form  $k\sqrt{2}$ , where  $k$  is an integer.

[4]

- 3 The diagram shows a triangle  $ABC$  inscribed in the circle with centre  $O$ .  $BD$  is a tangent to the circle at  $B$  and  $AB$  is parallel to  $CD$ . Point  $M$  is the midpoint of  $BC$ .

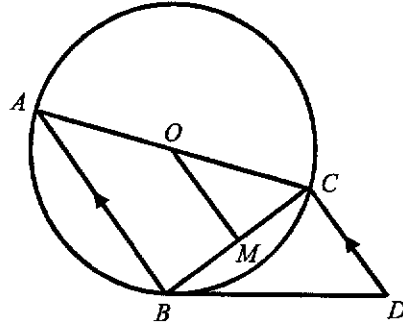

- (a) Prove that triangles  $ABC$  and  $BCD$  are similar.

[3]

- (b) Prove that  $ABMO$  is a trapezium.

[2]

(c) Prove that  $OM = \frac{BC^2}{2CD}$ .

[3]

- 4 Milk is poured into an empty cup and heated. The temperature,  $T_m$  °C, of the milk in the cup,  $t$  minutes after it is heated, is modelled by the formula,  $T_m = 5(2)^t + 20$ .

(a) State the initial temperature of the milk. [1]

Coffee is poured into another empty cup. The temperature,  $T_c$  °C, of the coffee in the cup,  $t$  minutes after it is poured, is modelled by the formula,  $T_c = 60(2)^{-t} + 25$ .

(b) Find the time taken for the temperature of the coffee to drop to 35°C. [3]

- (c) Find the time taken for the milk and the coffee to reach the same temperature. [4]

5 It is given that  $f(x) = 2x^3 - x^2y - 13xy^2 - 6y^3$ .

(a) Show that  $x - 3y$  is a factor of  $f(x)$ . [2]

(b) If  $y = 1$ , find an expression in fully factorised form for  $f(x)$ . [3]

- (c) Hence solve the equation  $2e^{6z} - e^{4z} - 13e^{2z} - 6 = 0$  and show that the solution may be written in the form  $\ln \sqrt{p}$ , where  $p$  is an integer. [3]

6 (a) Given that  $\tan \theta = 2\operatorname{cosec} \theta$ , show that  $\cos^2 \theta + 2\cos \theta - 1 = 0$ . [3]

(b) Using part (a), find the exact value of  $\cos \theta$  in simplest form, given that  $0^\circ < \theta < 90^\circ$ . [3]

- (c) Hence find the value of  $\sec^2 \theta$  in the form  $a + b\sqrt{2}$ , where  $a$  and  $b$  are integers. [5]

7 (a) Prove that  $(\sin 2x)(\cot x) - 1 = \cos 2x$ .

[2]

(b) Given that  $y = (\sin 2x)(\cot x) - 1$ , hence show that  $\frac{d^2y}{dx^2} + 3\left(\frac{dy}{dx}\right) + 2y + 9\sin 2x = 0$  may be written in the form  $\tan 2x = k$ , where  $k$  is a constant to be found.

[4]

(c) Solve  $\tan 2x = -\sqrt{3}$  for  $0 \leq x \leq 2\pi$ , giving your answers in terms of  $\pi$ .

[4]

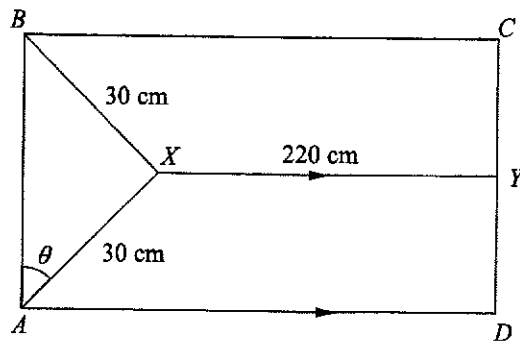

The diagram shows a rectangular flag  $ABCD$ .  $XAB$  is a triangle with  $AX = BX = 30$  cm and angle  $XAB = \theta$  for  $0 < \theta < 90^\circ$ .  $XY$  is parallel to  $AD$  and  $XY = 220$  cm.

(a) Express the area of triangle  $XAB$  in the form  $q \sin 2\theta$ , where  $q$  is an integer. [2]

(b) Given that  $\theta$  can vary, find the maximum possible area of triangle  $XAB$  and the value of  $\theta$  at which this occurs. [2]

- (c) Show that the perimeter,  $P$  cm, of the rectangular flag  $ABCD$  can be expressed in the form  $a \sin \theta + b \cos \theta + c$ , where  $a$ ,  $b$  and  $c$  are constants to be found. [3]

- (d) By expressing  $P$  in the form  $R \sin(\theta + \alpha) + c$ , where  $R > 0$  and  $0 < \alpha < 90^\circ$ , explain if it is possible to have a flag with perimeter 550 cm. Show your working clearly. [5]

- 9 A particle moves in a straight line so that,  $t$  seconds after passing a fixed point  $O$ , its velocity,  $v$  metres per second, is given by  $v = \pi \cos(\pi t) + \pi$ .

- (a) Sketch the velocity-time graph of the particle for  $0 \leq t \leq 4$ . [3]

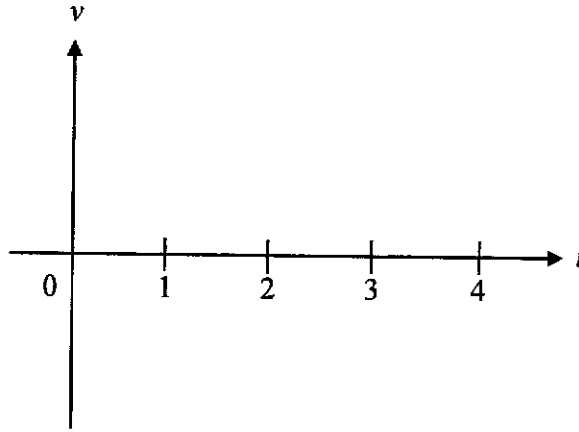

- (b) Determine how many times the particle is at instantaneous rest in the first 10 seconds. [1]

- (c) Explain why the particle will never return to the origin  $O$ . [2]

(d) Find an expression, in terms of  $t$ , for the displacement of the particle. [2]

(e) Calculate the average speed of the particle in the first 4 seconds. [3]

- 10 It is known that  $x$  and  $y$  are related by the equation  $y = \sqrt{Ax + \frac{B}{x}} - 2$ , where  $A$  and  $B$  are positive constants. The following table shows the values of the variables,  $x$  and  $y$ .

$x$	2	3	4	5	6
$y$	1.92	1.26	0.881	0.646	0.490

- (a) Plot  $x(y+2)^2$  against  $x^2$  and draw a straight line graph to illustrate the information. [3]

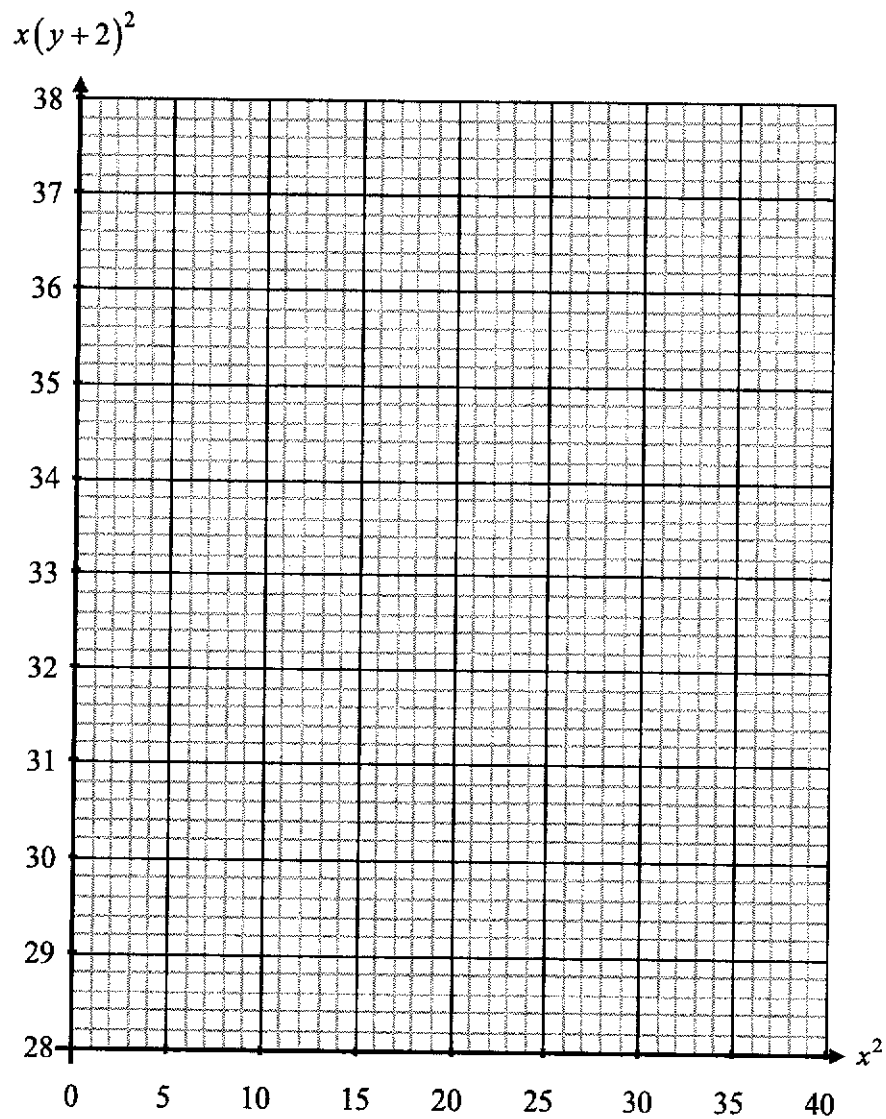

- (b) Express the equation  $y = \sqrt{Ax + \frac{B}{x}} - 2$  in a form that will yield the straight line graph in part (a). [2]

- (c) Use your graph to estimate the value of  $A$  and of  $B$ . [2]

- (d) Explain why the graph  $y = \sqrt{Ax + \frac{B}{x}} - 2$  is undefined for  $x \leq 0$ . [2]

- (e) By drawing a suitable line on your graph, estimate the value of  $x$  for which  $y + 2 = \frac{6}{\sqrt{x}}$ .  
Give your answer to 3 significant figures. [2]

**END OF PAPER**

Name:	Index No.:	Class:
-------	------------	--------

# PRESBYTERIAN HIGH SCHOOL



## ADDITIONAL MATHEMATICS Paper 2

4049/02

20 August 2024

Tuesday

2 hours 15 min

*PRESBYTERIAN HIGH SCHOOL PRESBYTERIAN HIGH SCHOOL PRESBYTERIAN HIGH SCHOOL PRESBYTERIAN HIGH SCHOOL*  
*PRESBYTERIAN HIGH SCHOOL PRESBYTERIAN HIGH SCHOOL PRESBYTERIAN HIGH SCHOOL PRESBYTERIAN HIGH SCHOOL*  
*PRESBYTERIAN HIGH SCHOOL PRESBYTERIAN HIGH SCHOOL PRESBYTERIAN HIGH SCHOOL PRESBYTERIAN HIGH SCHOOL*  
*PRESBYTERIAN HIGH SCHOOL PRESBYTERIAN HIGH SCHOOL PRESBYTERIAN HIGH SCHOOL PRESBYTERIAN HIGH SCHOOL*  
*PRESBYTERIAN HIGH SCHOOL PRESBYTERIAN HIGH SCHOOL PRESBYTERIAN HIGH SCHOOL PRESBYTERIAN HIGH SCHOOL*

### 2024 SECONDARY FOUR EXPRESS / FIVE NORMAL (ACADEMIC) PRELIMINARY EXAMINATIONS

# MARK SCHEME

- 1 (a) Write down, and simplify, the first three terms in the expansion of  $\left(3 - \frac{2}{x}\right)^5$  in descending powers of  $x$ . [2]

$$\left(3 - \frac{2}{x}\right)^5 = 3^5 + 5(3)^4 \left(-\frac{2}{x}\right) + \binom{5}{2}(3)^3 \left(-\frac{2}{x}\right)^2 + \dots$$

$$\left(3 - \frac{2}{x}\right)^5 = 243 - \frac{810}{x} + \frac{1080}{x^2} + \dots$$

B2: Three correct terms

(B1: Two correct terms)

- (b) Given that there is no term independent of  $x$  in the expansion of  $(5 + ax^2)\left(3 - \frac{2}{x}\right)^5$ , hence find the value of the constant  $a$ . [3]

$$(5 + ax^2)\left(3 - \frac{2}{x}\right)^5 = (5 + ax^2)\left(243 - \frac{810}{x} + \frac{1080}{x^2} + \dots\right)$$

$$\text{Term independent of } x = (5)(243) + (ax^2)\left(\frac{1080}{x^2}\right)$$

M1: Derive terms indep. of  $x$

$$\Rightarrow 1215 + 1080a = 0$$

M1: Equate terms to zero

$$\Rightarrow a = -\frac{1215}{1080} = -1.125$$

A1: Accept  $-1\frac{1}{8}$  or  $-\frac{9}{8}$

- 2 In the figure,  $ABCD$  is a rectangle inscribed within a semicircle of radius 4 cm and centre  $O$ . It is given that  $AB = x$  cm and  $BC = y$  cm.

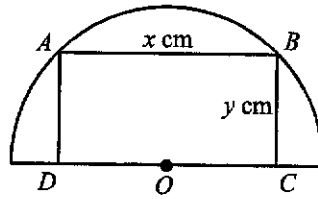

- (a) Show that the area of the rectangle,  $A$  cm, is given by  $A = \frac{1}{2}x\sqrt{64-x^2}$ . [2]

$$y^2 = 4^2 - \left(\frac{1}{2}x\right)^2$$

$$y = \sqrt{16 - \frac{1}{4}x^2}$$

M1: Correct application of Pythagoras Theorem

$$A = x\sqrt{16 - \frac{1}{4}x^2}$$

$$A = x\sqrt{\frac{1}{4}\sqrt{64-x^2}}$$

M1: Factorise and simplify surd

$$A = \frac{1}{2}x\sqrt{64-x^2}$$

(a.g.)

- (b) Find the exact value of  $x$  for which  $A$  has a stationary value.  
Give your answer in the form  $k\sqrt{2}$ , where  $k$  is an integer. [4]

$$\frac{dA}{dx} = \frac{1}{2}x \cdot \left[ \frac{1}{2}(64-x^2)^{-\frac{1}{2}} \cdot (-2x) \right] + \sqrt{64-x^2} \cdot \left( \frac{1}{2} \right)$$

M1, M1: Product rule

$$\frac{dA}{dx} = -\frac{1}{2}x^2(64-x^2)^{-\frac{1}{2}} + \frac{1}{2}(64-x^2)^{\frac{1}{2}}$$

$$\frac{dA}{dx} = \frac{1}{2}(64-x^2)^{-\frac{1}{2}} \left[ -x^2 + (64-x^2) \right] = \frac{32-x^2}{\sqrt{64-x^2}}$$

For stationary value,  $\frac{dA}{dx} = \frac{32-x^2}{\sqrt{64-x^2}} = 0$

M1: Equate  $dA/dx$  to zero

$$32 - x^2 = 0$$

$$x = \sqrt{32} = 4\sqrt{2}$$

A1

- 3 The diagram shows a triangle  $ABC$  is inscribed in the circle with centre  $O$ .  $BD$  is a tangent to the circle at  $B$  and  $AB$  is parallel to  $CD$ . Point  $M$  is the midpoint of  $BC$ .

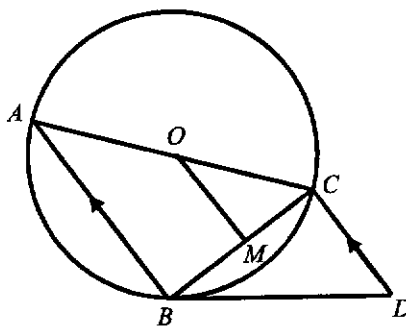

- (a) Prove that triangles  $ABC$  and  $BCD$  are similar. [3]

$$\angle ABC = \angle BCD \text{ (alt. } \angle\text{s, } AB \parallel CD) \quad \text{M1}$$

$$\angle BAC = \angle CBD \text{ (alternate segment theorem)}$$

$$\text{Triangles } ABC \text{ and } BCD \text{ are similar. (AA similarity) \quad A1}$$

- (b) Prove that  $ABMO$  is a trapezium. [2]

Since  $O$  and  $M$  are the midpoints of  $AC$  and  $BC$  respectively,

$OM \parallel AB$  (midpoint theorem) M1

$ABMO$  is a trapezium. (one pair of parallel sides) A1

- (c) Prove that  $OM = \frac{BC^2}{2CD}$ . [3]

$$\frac{AB}{BC} = \frac{BC}{CD} \text{ (corr. sides of similar } \Delta\text{s) \quad M1}$$

$$\text{Since } AB = 2OM \text{ (midpoint theorem) \quad M1}$$

$$\Rightarrow \frac{2OM}{BC} = \frac{BC}{CD}$$

$$\therefore OM = \frac{BC^2}{2CD} \quad \text{A1}$$

\*Penalise 1m per question for any missing or incorrect reasons.

- 4 Milk is poured into an empty cup and heated. The temperature,  $T_m$  °C, of the milk in the cup,  $t$  minutes after it is heated, is modelled by the formula,  $T_m = 5(2)^t + 20$ .

(a) State the initial temperature of the milk. [1]

Initial temperature of milk = $5(2)^0 + 20 = 25^\circ\text{C}$	B1
--	----

Coffee is poured into another empty cup. The temperature,  $T_c$  °C, of the coffee in the cup,  $t$  minutes after it is poured, is modelled by the formula,  $T_c = 60(2)^{-t} + 25$ .

(b) Find the time taken for the temperature of the coffee to drop to  $35^\circ\text{C}$ . [3]

$60(2)^{-t} + 25 = 35$	
$(2)^{-t} = \frac{35 - 25}{60} = \frac{1}{6}$	M1: Isolate $(2)^{-t}$
$\lg(2)^{-t} = \lg\left(\frac{1}{6}\right)$	M1: Take lg on both sides
$-t \lg(2) = \lg\left(\frac{1}{6}\right)$	
$t = -\lg\left(\frac{1}{6}\right) \div \lg(2) = 2.5849$	
$t \approx 2.58 \text{ min (3sf)}$	A1

(c) Find the time taken for the milk and the coffee to reach the same temperature. [4]

$5(2)^t + 20 = 60(2)^{-t} + 25$	M1: Equate $T_m$ to $T_c$			
$5(2)^{2t} + 20(2)^t = 60 + 25(2)^t$	M1: Multiply $2^t$ throughout / obtain quad. eqn.			
$5(2)^{2t} - 5(2)^t - 60 = 0$				
$(2)^{2t} - (2)^t - 12 = 0$				
Let $u = (2)^t$ , $u^2 - u - 12 = 0$	<table border="1" style="margin-left: auto; margin-right: auto; border-collapse: collapse;"> <tr> <td style="padding: 5px;">Let <math>u = (2)^t</math>, <math>5u + 20 = \frac{60}{u} + 25</math></td> </tr> <tr> <td style="padding: 5px;"><math>5u^2 - 5u - 60 = 0</math></td> </tr> <tr> <td style="padding: 5px;"><math>u^2 - u - 12 = 0</math></td> </tr> </table>	Let $u = (2)^t$ , $5u + 20 = \frac{60}{u} + 25$	$5u^2 - 5u - 60 = 0$	$u^2 - u - 12 = 0$
Let $u = (2)^t$ , $5u + 20 = \frac{60}{u} + 25$				
$5u^2 - 5u - 60 = 0$				
$u^2 - u - 12 = 0$				
$(u - 4)(u + 3) = 0$	M1: Solve quadratic equation			
$u = 4$ or $u = -3$ (rejected)				
$(2)^t = 4$				
$t = 2 \text{ min}$	A1			

5 It is given that  $f(x) = 2x^3 - x^2y - 13xy^2 - 6y^3$ .

(a) Show that  $x - 3y$  is a factor of  $f(x)$ . [2]

$$f(3y) = 2(3y)^3 - (3y)^2y - 13(3y)y^2 - 6$$

$$f(3y) = 54y^3 - 9y^3 - 39y^3 - 6y^3 = 0$$

M1: Sub. into  $f(x)$  & simplify

Since  $f(3y) = 0$ , by Factor Theorem,  $x - 3y$  is a factor of  $f(x)$ . AG1

(b) If  $y = 1$ , find an expression in fully factorised form for  $f(x)$ . [3]

$$\text{Let } f(x) = 2x^3 - x^2 - 13x - 6$$

$$= (x-3)[2x^2 + bx + 2]$$

Comparing  $x^2$  term:

$$-1 = b + (-3)(2)$$

$$b = 5$$

M1: Comparing coefficient  
(or long division)

$$\Rightarrow f(x) = (x-3)[2x^2 + 5x + 2]$$

A1

$$\Rightarrow f(x) = (x-3)(2x+1)(x+2)$$

A1

(c) Hence solve the equation  $2e^{6z} - e^{4z} - 13e^{2z} - 6 = 0$  and show that the solution may be written in the form  $\ln \sqrt{p}$ , where  $p$  is an integer. [3]

$$\text{Let } x = e^{2z},$$

$$\text{we get } 2e^{6z} - e^{4z} - 13e^{2z} - 6 = 0$$

$$\Rightarrow (e^{2z} - 3)(2e^{2z} + 1)(e^{2z} + 2) = 0$$

M1: Sub.  $x = e^{2z}$  into (b)

$$\Rightarrow e^{2z} = 3 \quad \text{or} \quad 2e^{2z} = -1(\text{rejected}) \quad \text{or} \quad e^{2z} = -2(\text{rejected}) \quad \text{A1: Seen } e^{2z} = 3$$

$$\ln e^{2z} = \ln 3$$

$$2z = \ln 3$$

$$z = \frac{1}{2} \ln 3$$

$$\therefore z = \ln \sqrt{3}$$

A1

- 6 (a) Given that  $\tan \theta = 2\operatorname{cosec} \theta$ , show that  $\cos^2 \theta + 2\cos \theta - 1 = 0$ . [3]

$\tan \theta = 2\operatorname{cosec} \theta$	
$\frac{\sin \theta}{\cos \theta} = \frac{2}{\sin \theta}$	M1: Seen either one
$\sin^2 \theta = 2\cos \theta$	
$1 - \cos^2 \theta = 2\cos \theta$	M1: Apply Pythagorean identity
$\cos^2 \theta + 2\cos \theta - 1 = 0$	AG1

- (b) Using part (a), find the exact value of  $\cos \theta$  in simplest form, given that  $0^\circ < \theta < 90^\circ$ . [3]

$\cos^2 \theta + 2\cos \theta - 1 = 0$	
$\cos \theta = \frac{-2 \pm \sqrt{2^2 - 4(1)(-1)}}{2(1)}$	M1: Apply quadratic formula
$\cos \theta = \frac{-2 \pm \sqrt{8}}{2}$	
$\cos \theta = -1 \pm \sqrt{2}$	M1: Attempt to simplify
Since $0^\circ < \theta < 90^\circ$ , $\cos \theta$ must be positive.	
$\therefore \cos \theta = -1 + \sqrt{2}$	A1

- (c) Hence find the value of  $\sec^2 \theta$  in the form  $a + b\sqrt{2}$ , where  $a$  and  $b$  are integers. [5]

$\sec^2 \theta = \frac{1}{\cos^2 \theta}$	M1: Seen $\frac{1}{\cos^2 \theta}$
$\sec^2 \theta = \frac{1}{(-1 + \sqrt{2})^2}$	
$\sec^2 \theta = \frac{1}{(\sqrt{2})^2 - 2(\sqrt{2})(1) + 1^2}$	M1: Expand the denominator
$\sec^2 \theta = \frac{1}{3 - 2\sqrt{2}} \times \frac{3 + 2\sqrt{2}}{3 + 2\sqrt{2}}$	M1: Rationalise the denominator
$\sec^2 \theta = \frac{3 + 2\sqrt{2}}{3^2 - (2\sqrt{2})^2}$	M1: Simplify the denominator
$\sec^2 \theta = 3 + 2\sqrt{2}$	A1

- 7 (a) Prove that  $(\sin 2x)(\cot x) - 1 = \cos 2x$ . [2]

$$\begin{aligned} LHS &= (\sin 2x)(\cot x) - 1 \\ &= (2 \sin x \cos x) \left( \frac{\cos x}{\sin x} \right) - 1 && \text{M1: Seen } 2\sin x \cos x \\ &= 2 \cos^2 x - 1 && \text{M1} \\ &= \cos 2x = RHS && \text{(a.g)} \end{aligned}$$

- (b) Given that  $y = (\sin 2x)(\cot x) - 1$ , hence show that  $\frac{d^2 y}{dx^2} + 3\left(\frac{dy}{dx}\right) + 2y + 9 \sin 2x = 0$  may be written in the form  $\tan 2x = k$ , where  $k$  is a constant to be found. [4]

$$\begin{aligned} y &= (\sin 2x)(\cot x) - 1 = \cos 2x \\ \frac{dy}{dx} &= -2 \sin 2x && \text{B1} \\ \frac{d^2 y}{dx^2} &= -4 \cos 2x && \text{B1} \\ \frac{d^2 y}{dx^2} + 3\left(\frac{dy}{dx}\right) + 2y + 9 \sin 2x &= 0 \\ -4 \cos 2x + 3(-2 \sin 2x) + 2 \cos 2x + 9 \sin 2x &= 0 && \text{M1: Correct substitution} \\ 3 \sin 2x &= 2 \cos 2x \\ \tan 2x &= \frac{2}{3} \\ \therefore k &= \frac{2}{3} && \text{A1} \end{aligned}$$

- (c) Solve  $\tan 2x = -\sqrt{3}$  for  $0 \leq x \leq 2\pi$ , giving your answers in terms of  $\pi$ . [4]

$$\begin{aligned} \alpha &= \tan^{-1}(\sqrt{3}) = \frac{\pi}{3} && \text{M1: Find reference angle} \\ 2x &= \pi - \frac{\pi}{3}, 2\pi - \frac{\pi}{3}, 3\pi - \frac{\pi}{3}, 4\pi - \frac{\pi}{3} && \text{M1: Find angles in 2}^{\text{nd}} \text{ and 4}^{\text{th}} \text{ quadrants} \\ 2x &= \frac{2\pi}{3}, \frac{5\pi}{3}, \frac{8\pi}{3}, \frac{11\pi}{3} \\ x &= \frac{\pi}{3}, \frac{5\pi}{6}, \frac{4\pi}{3}, \frac{11\pi}{6} && \text{A2: One mark for each correct pair of angles} \end{aligned}$$

\*Penalise 1m for answers not in terms of  $\pi$ .

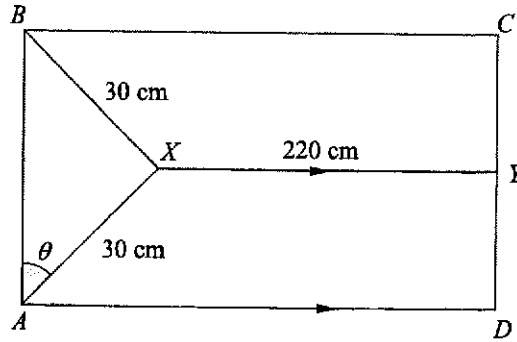

The diagram shows a rectangular flag  $ABCD$ .  $XAB$  is a triangle with  $AX = BX = 30$  cm and angle  $XAB = \theta$  for  $0 < \theta < 90^\circ$ .  $XY$  is parallel to  $AD$  and  $XY = 220$  cm.

- (a) Express the area of triangle  $XAB$  in the form  $q \sin 2\theta$ , where  $q$  is an integer. [2]

Area of triangle $XAB = \frac{1}{2}(30)(30)\sin(180^\circ - 2\theta)$	M1: Apply formula $\frac{1}{2}bc\sin A$
Area of triangle $XAB = 450\sin 2\theta$	A1

- (b) Given that  $\theta$  can vary, find the maximum possible area of triangle  $XAB$  and the value of  $\theta$  at which this occurs. [2]

This occurs when  $\sin 2\theta = 1$ ,

Maximum area of triangle $XAB = 450 \text{ cm}^2$	B1: F.T.
---	----------

Value of $\theta = 45^\circ$	B1
------------------------------	----

- (c) Show that the perimeter,  $P$  cm, of the rectangular flag  $ABCD$  can be expressed in the form  $a \sin \theta + b \cos \theta + c$ , where  $a$ ,  $b$  and  $c$  are constants to be found. [3]

$AD = 30 \sin \theta + 220$	
-----------------------------	--

$AB = 2 \times 30 \cos \theta$	M1: Either $AD$ or $AB$
--------------------------------	-------------------------

Perimeter = $2[30 \sin \theta + 220] + 2[2 \times 30 \cos \theta]$	M1: Attempt to find perimeter
--	-------------------------------

$P = 60 \sin \theta + 120 \cos \theta + 440$	A1
--	----

- (d) By expressing  $P$  in the form  $R \sin(\theta + \alpha) + c$ , where  $R > 0$  and  $0 < \alpha < 90^\circ$ , explain

if it is possible to have a flag with perimeter 550 cm. Show your working clearly. [5]

$$R = \sqrt{60^2 + 120^2} = \sqrt{18000} = 60\sqrt{5}$$

$$\text{M1: Seen } R = \sqrt{a^2 + b^2}$$

$$\alpha = \tan^{-1}\left(\frac{120}{60}\right) = 63.434^\circ$$

$$\text{M1: Seen } \alpha = \tan^{-1} \frac{b}{a}$$

$$P = 60\sqrt{5} \sin(\theta + 63.434^\circ) + 440$$

### Method 1

$$\text{Let } 60\sqrt{5} \sin(\theta + 63.434^\circ) + 440 = 550$$

$$\sin(\theta + 63.434^\circ) = \frac{550 - 440}{60\sqrt{5}}$$

$$\text{Reference angle} = \sin^{-1}\left(\frac{11}{6\sqrt{5}}\right) = 55.0739$$

M1: Find reference angle

$$\theta + 63.434^\circ = 55.0739^\circ \text{ or } 180^\circ - 55.0739^\circ$$

M1: Find  $\theta$  in 1<sup>st</sup> & 2<sup>nd</sup> quad

$$\theta = -8.3601^\circ \text{ (rejected) or } 61.4921^\circ$$

Yes, it is possible to have a flag with perimeter 550 cm when  $\theta \approx 61.5^\circ$  (1dp) A1

### Method 2

$$\text{Maximum } P = 60\sqrt{5} + 440 = 574 \text{ cm}$$

M1

$$\text{When } \theta = 90^\circ, \text{ Minimum } P = 60\sqrt{5} \sin(90^\circ + 63.434^\circ) + 440 = 500 \text{ cm}$$

M1

Since  $500 < P \leq 574$ , it is possible to have a flag with perimeter 550 cm. A1

- 9 A particle moves in a straight line so that,  $t$  seconds after passing a fixed point  $O$ , its velocity,  $v$  metres per second, is given by  $v = \pi \cos(\pi t) + \pi$ .

- (a) Sketch the velocity-time graph of the particle for  $0 \leq t \leq 4$ .

[3]

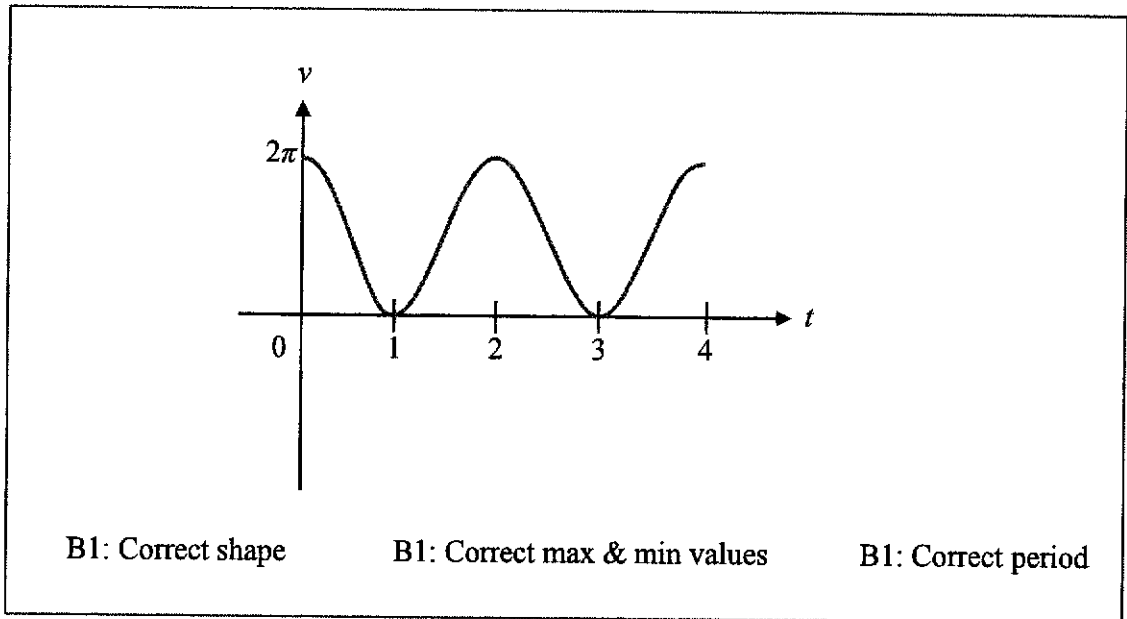

- (b) Determine how many times the particle is at instantaneous rest in the first 10 seconds. [1]

From the graph, the particle is at instantaneous rest when  $v = 0$  at every odd second.

Therefore, there are 5 times in the first 10 seconds.    B1

- (c) Explain why the particle will never return to the origin  $O$ .

[2]

Since  $v \geq 0$ , the **velocity** of the particle is **never negative**,    B1  
 hence the particle **does not change its direction of motion**.    B1  
 Therefore, the particle will never return to the origin  $O$ .    (a.g)

- (d) Find an expression, in terms of  $t$ , for the displacement of the particle.

[2]

$$s = \int \pi \cos(\pi t) + \pi \, dt$$

$$s = \frac{\pi \sin(\pi t)}{\pi} + \pi t + c$$

M1: Apply integration

When  $t = 0$ ,  $s = 0$ , thus  $c = 0$ .

(e) Calculate the average speed of the particle in the first 4 seconds.

[3]

When  $t = 0$ ,  $s = 0$ .

When  $t = 4$ ,  $s = \sin(4\pi) + 4\pi = 4\pi$

M1: Find displacement at  $t = 4$

Average speed =  $\frac{4\pi}{4}$

M1: Find average speed

Average speed =  $\pi$  m/s

A1

- 10 It is known that  $x$  and  $y$  are related by the equation  $y = \sqrt{Ax + \frac{B}{x}} - 2$ , where  $A$  and  $B$  are positive constants. The following table shows the values of the variables,  $x$  and  $y$ .

$x$	2	3	4	5	6
$y$	1.92	1.26	0.881	0.646	0.490

$x^2$	4	9	16	25	36
$x(y+2)^2$	30.7	31.9	33.2	35.0	37.2

- (a) Plot  $x(y+2)^2$  against  $x^2$  and draw a straight line graph to illustrate the information. [3]

B2: All correct points plotted (B1: at least 3 correct)

B1: Best fit line

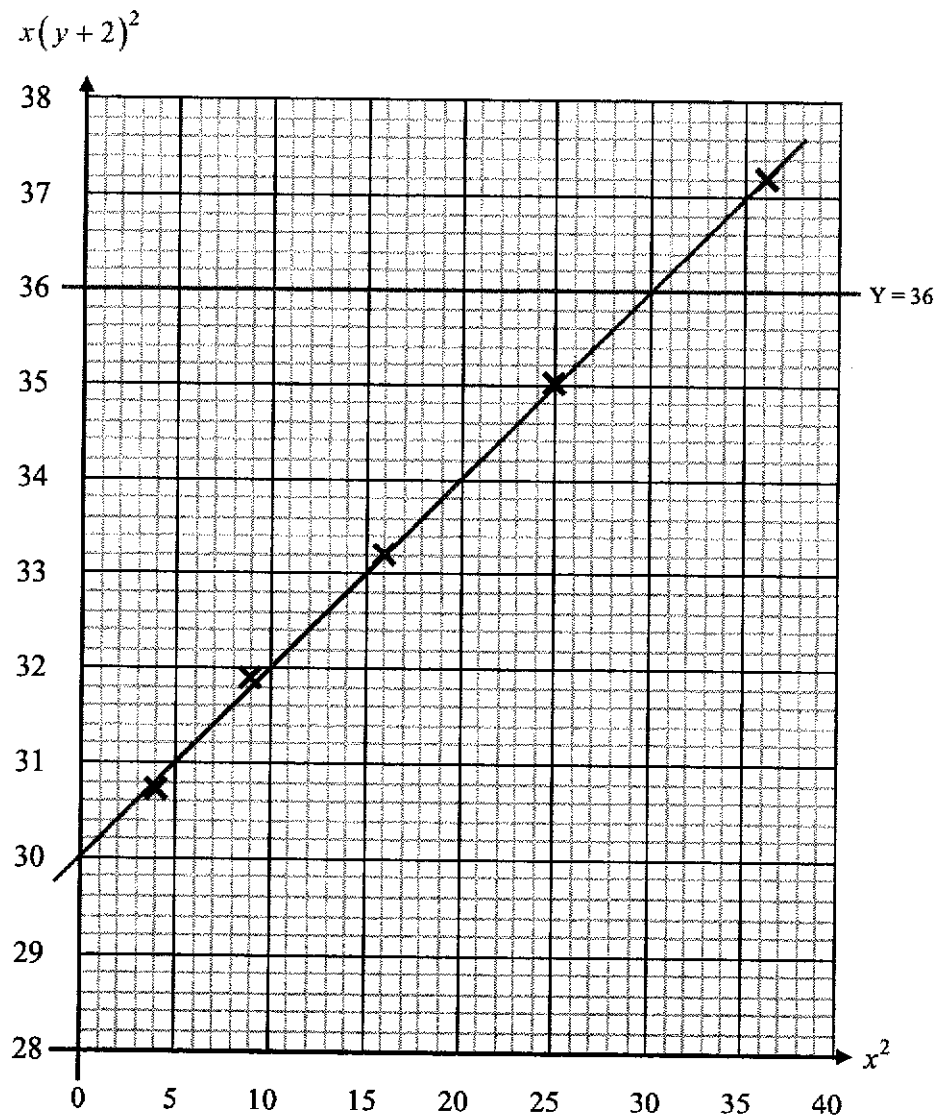

- (b) Express the equation  $y = \sqrt{Ax + \frac{B}{x}} - 2$  in a form that will yield the straight line graph in part (a). [2]

$$y = \sqrt{Ax + \frac{B}{x}} - 2$$

$$y + 2 = \sqrt{Ax + \frac{B}{x}}$$

$$(y + 2)^2 = Ax + \frac{B}{x} \quad \text{M1: Taking square on both sides}$$

$$x(y + 2)^2 = Ax^2 + B \quad \text{A1}$$

- (c) Use your graph to estimate the value of  $A$  and of  $B$ . [2]

$$A = \text{gradient} = \frac{37.2 - 33.2}{36 - 16} = 0.2 \quad \text{B1: Accept +/- 0.01}$$

$$B = Y - \text{intercept} = 30 \quad \text{B1: Accept +/- 0.5}$$

- (d) Explain why the graph  $y = \sqrt{Ax + \frac{B}{x}} - 2$  is undefined for  $x \leq 0$ . [2]

When  $x = 0$ ,  $\frac{B}{x}$  results in division by zero error. B1

When  $x < 0$ , since  $A > 0$  and  $B > 0$ ,  $Ax + \frac{B}{x} < 0$ , hence  $\sqrt{Ax + \frac{B}{x}}$  has no real roots. B1

Hence,  $y = \sqrt{Ax + \frac{B}{x}} - 2$  is undefined for  $x \leq 0$ . (a.g.)

- (e) By drawing a suitable line on your graph, estimate the value of  $x$  for which  $y + 2 = \frac{6}{\sqrt{x}}$ . [2]  
Give your answer to 3 significant figures.

$$y + 2 = \frac{6}{\sqrt{x}}$$

$$(y + 2)^2 = \frac{36}{x} \quad \text{B1: Draw } Y = 36 \text{ on the same axes}$$

$$x(y + 2)^2 = 36$$

From the graph, when  $x(y + 2)^2 = 36$ ,  $x^2 = 30$

$$\therefore x = \sqrt{30} = 5.4772 \approx 5.48 \text{ (3sf)} \quad \text{B1: Accept +/- 0.1}$$