

Visit

[FreeTestPaper.com](http://FreeTestPaper.com)

for more papers



4 1300 cm<sup>3</sup> of liquid A of mass 900 g is mixed with 500 cm<sup>3</sup> of liquid B of mass 650 g. What is the final density of the mixture?

- A 0.608 g/cm<sup>3</sup>                      B 0.861 g/cm<sup>3</sup>  
 C 1.16 g/cm<sup>3</sup>                        D 1.99 g/cm<sup>3</sup>

5 A stunt man weighing 600 N stands at the edge of a horizontal board as shown in the diagram. Assuming that the board is weightless, what is the tension in the rope?

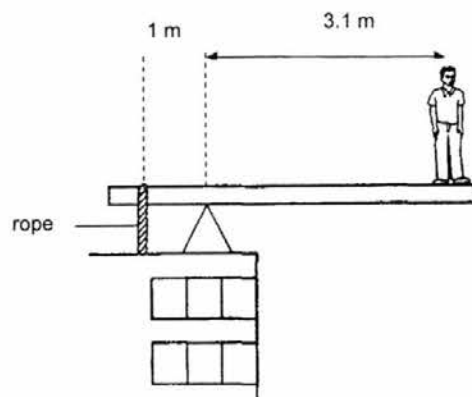

- A 245 N                                      B 600 N  
 C 1470 N                                    D 1860 N

6 A 2 kW electric motor is used to operate a winding machine. If it raises the load vertically up by 10 m in 2 s, what is the weight of the load?

- A 200 N                                      B 400 N  
 C 20 000 N                                D 40 000 N

7 When a liquid evaporates, some molecules escape from it and its temperature is affected. From where do the molecules escape and what is the effect on the temperature of the liquid?

	molecules escape from	temperature of liquid
A	all parts of the liquid	decreases
B	all parts of the liquid	increases
C	only the liquid surface	decreases
D	only the liquid surface	increases

8 A heater is placed in the middle of two enclosed containers A and B as shown in the diagram below. After 5 minutes of heating, the temperature in container A appears to be higher than in container B.

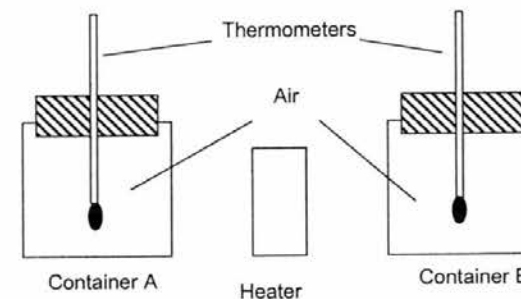

Which of the following best describes the surfaces of the two containers?

- | <u>Container A</u> | <u>Container B</u>  |
|--------------------|---------------------|
| A smooth           | rough               |
| B black in colour  | white in colour     |
| C shiny            | dull                |
| D silver in colour | dark blue in colour |

- 9 A substance was heated in an enclosed space until it became a gas. After the heater was removed, the temperature of the substance was recorded at regular intervals. The graph shows the temperature plotted against time.

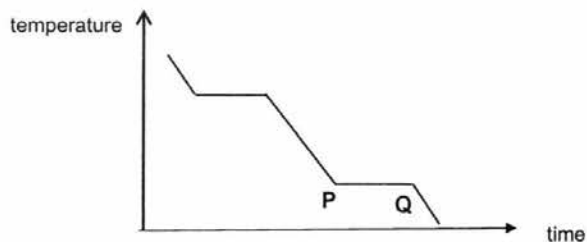

What does the section PQ represent?

- A boiling  
 B condensation  
 C melting  
 D solidifying
- 10 An optician's test card is placed a distance behind a man who is standing 3.5 m away from a plane mirror. The distance from the man's eyes to the image of the test card is 8.5 m.

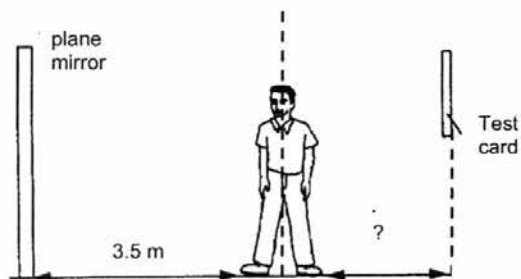

What is the distance of the test card from the man?

- A 1.5 m  
 B 3.0 m  
 C 3.5 m  
 D 5.0 m

- 11 The diagram below shows a light ray travelling from medium N into air.

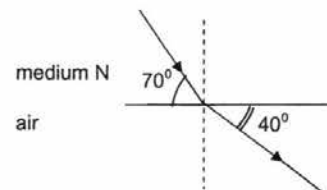

What is the refractive index of medium N?

- A 0.446  
 B 0.684  
 C 1.46  
 D 2.24
- 12 Which of the following statements is not true about all electromagnetic waves?
- A They are transverse waves.  
 B They can travel in vacuum.  
 C They carry with them energy.  
 D They travel at the same speed in liquids.
- 13 The diagram below shows a bar in a dipper tank vibrating at 5 Hertz.

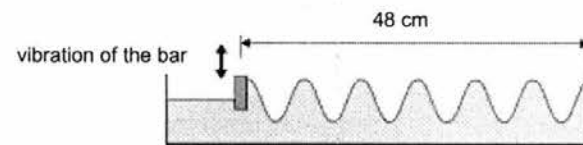

Find the speed of the wave.

- A 0.4 m/s  
 B 2.4 m/s  
 C 40 m/s  
 D 240 m/s



- 20 Four current carrying wires are placed between two magnets as shown in the diagrams below. Which of the following diagrams shows the correct direction of the force experienced by the wire?

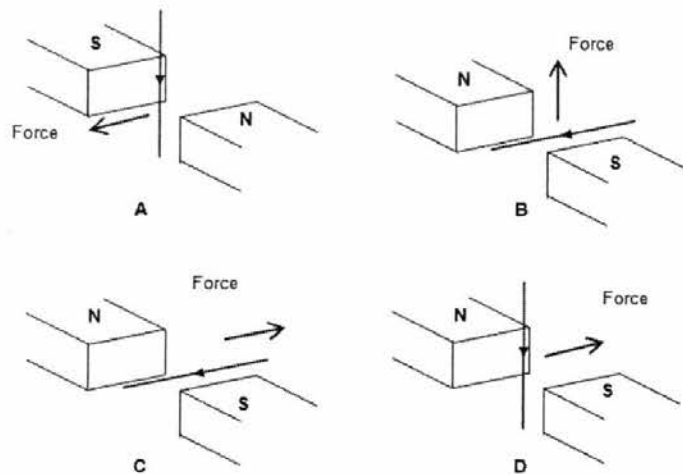

- 21 Which statement about the molecules in ice is correct?

- A The molecules all move with the same speed.
- B The molecules are diatomic.
- C The molecules move randomly.
- D The molecules vibrate about fixed positions.

- 22 A liquid is thought to be pure ethanol. What is the best way to test its purity?

- A burns it completely in oxygen
- B measure its boiling point
- C reacts it with ethanoic acid
- D shake the liquid with water

- 23 A test tube containing solid X was placed in a beaker of boiling water. The solid X started to melt immediately.

What is the melting point of the solid X?

- A above  $100^{\circ}\text{C}$
- B between room temperature and  $100^{\circ}\text{C}$
- C exactly  $100^{\circ}\text{C}$
- D less than  $0^{\circ}\text{C}$

- 24 "Solid M is blue and dissolves in water. Its solution can be separated into three dyes by chromatography."

Classify M.

- A M is a mixture.
- B M is a nucleon.
- C M is a sodium salt.
- D M is an alkali.

25 The nucleon number of an isotope of bromine is 81.

How many protons, neutrons and electrons are present in an atom of this isotope?

	protons	neutrons	electrons
A	35	46	35
B	35	46	46
C	37	44	35
D	37	44	37

26 The element with electronic configuration 2, 8, 5 .....

- A forms a covalent compound with calcium.
- B forms an ion of charge -3.
- C is a metal.
- D reacts only with non-metals.

27 25.0 cm<sup>3</sup> of aqueous 0.1 mol/dm<sup>3</sup> hydrochloric acid exactly neutralises 20.00 cm<sup>3</sup> of aqueous sodium hydroxide.

The equation for this reaction is



What is the concentration of the sodium hydroxide solution?

- A 0.080 mol/dm<sup>3</sup>
- B 0.800 mol/dm<sup>3</sup>
- C 0.125 mol/dm<sup>3</sup>
- D 1.25 mol/dm<sup>3</sup>

28 Which compound is a base?

- A carbon dioxide
- B magnesium oxide
- C water
- D zinc carbonate

29 In which reaction is a salt not formed?

- A copper(II) oxide with dilute hydrochloric acid
- B copper(II) oxide with hydrogen
- C copper(II) sulfate with barium chloride
- D copper(II) sulfate with sodium hydroxide

30 Which equation represent a redox reaction?

- A  $\text{Ag}^+ + \text{Cl}^- \rightarrow \text{AgCl}$
- B  $\text{Cl}_2 + 2\text{I}^- \rightarrow 2\text{Cl}^- + \text{I}_2$
- C  $\text{H}^+ + \text{OH}^- \rightarrow \text{H}_2\text{O}$
- D  $\text{H}_2\text{O} + \text{SO}_3 \rightarrow \text{H}_2\text{SO}_4$

31 The table gives information about five chemical elements.

element	density (g/cm <sup>3</sup> )	melting point (°C)	electrical conductivity
A	0.97	97.8	good
B	1.00	0	poor
C	3.12	-7.2	poor
D	8.96	1083	good

Which element could be copper?

- 32 The results of adding a halogen to halide solutions are shown in the table below.

experiment	halogen added	halide solution containing		
		X <sup>-</sup>	Y <sup>-</sup>	Z <sup>-</sup>
1	X <sub>2</sub>		Y <sub>2</sub> displaced	Z <sub>2</sub> displaced
2	Y <sub>2</sub>	no reaction		no reaction
3	Z <sub>2</sub>	no reaction	Y <sub>2</sub> displaced	

What were the halogens, X, Y and Z?

	X	Y	Z
A	Br	Cl	I
B	Br	I	Cl
C	Cl	Br	I
D	Cl	I	Br

- 33 Which one of the following is a correct statement about an endothermic reaction?

- A It is a reaction which cools down the surroundings.
- B Light is given out during the reaction.
- C More molecules are formed than are used in the reaction.
- D Water is needed for the reaction to take place.

- 34 What would be the best way of slowing down the reaction between magnesium and hydrochloric acid?

- A dilute the acid used in the reaction
- B stir the reagents
- C heat up the acid
- D use magnesium powder instead of ribbon

- 35 "A catalyst is a substance which increases the speed of a chemical reaction and remains chemically unchanged at the end of the reaction."

Copper(II) oxide catalyses the decomposition of aqueous hydrogen peroxide.



Aqueous hydrogen peroxide was shaken with copper(II) oxide in a test-tube.

What did the test-tube contain when the reaction was complete?

- A a black solid
- B a black solid and a blue liquid
- C a blue liquid only
- D a light blue solid and a colourless liquid

- 36 Which of the following, when burnt, is most likely to cause an increase in the concentration of 'acid rain' in the atmosphere?

- A hydrogen
- B lead
- C magnesium
- D sulfur

- 37 The structure of a polymer molecule may be shown as:

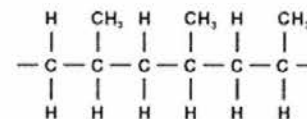

From which of the following hydrocarbons can the polymer be made?

- A C<sub>2</sub>H<sub>4</sub>
- B C<sub>3</sub>H<sub>6</sub>
- C C<sub>3</sub>H<sub>8</sub>
- D C<sub>4</sub>H<sub>8</sub>

- 38 In coal mines, the percentage of methane in the air is continually checked.

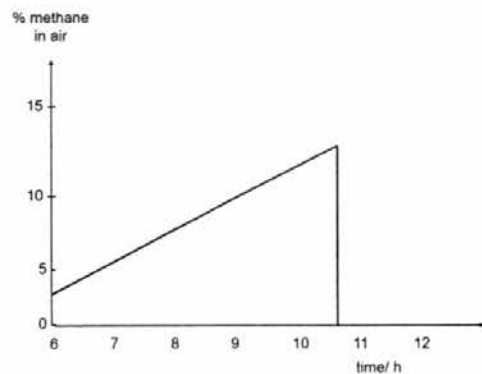

What is most likely to have caused the sudden fall in the methane percentage shown on the graph?

- A The temperature in the mine was lowered.
- B The ventilator fans were switched on.
- C An explosive mixture of methane and air ignited.
- D Methane stopped seeping into the mine.
- 39 An organic compound **U** is boiled in acidified potassium manganate(VII) to give a compound with molecular formula  $\text{CH}_3\text{COOH}$ . What is compound **U**?
- A butene
- B ethanol
- C propane
- D propanoic acid

- 40 Which reaction does not produce carbon dioxide?

- A combustion of methane
- B fermentation of sugar
- C poly(ethene) production
- D reaction of ethanoic acid with calcium carbonate

END OF PAPER

# The Periodic Table of the Elements

		Group																																																																																												
I	II	III	IV	V	VI	VII	VIII	IX	X	XI	XII	XIII	XIV	XV	XVI	XVII	XVIII																																																																													
7 Li lithium 3	9 Be beryllium 4	11 B boron 5	12 C carbon 6	13 Al aluminium 13	14 Si silicon 14	15 P phosphorus 15	16 S sulfur 16	17 Cl chlorine 17	18 Ar argon 18	19 K potassium 19	20 Ca calcium 20	21 Sc scandium 21	22 Ti titanium 22	23 V vanadium 23	24 Cr chromium 24	25 Mn manganese 25	26 Fe iron 26	27 Co cobalt 27	28 Ni nickel 28	29 Cu copper 29	30 Zn zinc 30	31 Ga gallium 31	32 Ge germanium 32	33 As arsenic 33	34 Se selenium 34	35 Br bromine 35	36 Kr krypton 36	37 Rb rubidium 37	38 Sr strontium 38	39 Y yttrium 39	40 Zr zirconium 40	41 Nb niobium 41	42 Mo molybdenum 42	43 Tc technetium 43	44 Ru ruthenium 44	45 Rh rhodium 45	46 Pd palladium 46	47 Ag silver 47	48 Cd cadmium 48	49 In indium 49	50 Sn tin 50	51 Sb antimony 51	52 Te tellurium 52	53 I iodine 53	54 Xe xenon 54	55 Cs caesium 55	56 Ba barium 56	57 La lanthanum 57	58 Ce cerium 58	59 Pr praseodymium 59	60 Nd neodymium 60	61 Pm promethium 61	62 Sm samarium 62	63 Eu europium 63	64 Gd gadolinium 64	65 Tb terbium 65	66 Dy dysprosium 66	67 Ho holmium 67	68 Er erbium 68	69 Tm thulium 69	70 Yb ytterbium 70	71 Lu lutetium 71	72 Hf hafnium 72	73 Ta tantalum 73	74 W tungsten 74	75 Re rhenium 75	76 Os osmium 76	77 Ir iridium 77	78 Pt platinum 78	79 Au gold 79	80 Hg mercury 80	81 Tl thallium 81	82 Pb lead 82	83 Bi bismuth 83	84 Po polonium 84	85 At astatine 85	86 Rn radon 86	87 Fr francium 87	88 Ra radium 88	89 Ac actinium 89	90 Th thorium 90	91 Pa protactinium 91	92 U uranium 92	93 Np neptunium 93	94 Pu plutonium 94	95 Am americium 95	96 Cm curium 96	97 Bk berkelium 97	98 Cf californium 98	99 Es einsteinium 99	100 Fm fermium 100	101 Md mendelevium 101	102 No nobelium 102	103 Lr lawrencium 103

\*58-71 Lanthanoid series  
†90-103 Actinoid series

Key  

a	X
b	

  
 a = relative atomic mass  
 X = atomic symbol  
 b = proton (atomic) number

## Answers

1. A	11. D
2. B	12. D
3. C	13. A
4. B	14. B
5. D	15. C
6. B	16. D
7. C	17. C
8. B	18. C
9. D	19. D
10. A	20. B

Candidate Name: \_\_\_\_\_

Class:	
Index No:	

	<b>Chong Boon Secondary School</b> <b>Preliminary Examination 2016</b> <b>Secondary 4 Express/5 Normal (Academic)</b>
	<b>Science (Physics) 5076/02</b> <b>Paper 2</b>
<b>13<sup>th</sup> Sep 2016 (Tuesday)</b>	<b>1 hour 15 minutes</b>

Additional Materials:

**READ THESE INSTRUCTIONS FIRST**

**Do not open this booklet until you are told to do so.**

1. There are two sections in this paper

**Section A**

Answer all questions

Write your answers in the spaces provided

**Section B**

Answer any **two** questions.

Write your answers on the spaces provided.

**Information to Candidates**

1. The number of marks is given in brackets [ ] at the end of each question or part question.
2. Candidates are reminded that all quantitative answers should include appropriate units.
3. Candidates are advised to show all working in a clear and orderly manner, as marks are awarded for sound use of physics than for correct answers.
4. Electronic calculators are allowed to be used.
5. Unless otherwise stated, you are to take  $g$ , the acceleration due to gravity, to be  $10 \text{ m s}^{-2}$

For Examiner's Use
<b>65</b>

**SECTION A [45 Marks]**

Answer **ALL** questions. Write your answers in the spaces provided.

1 A car has a mass of 1400 kg. It can accelerate from rest to  $30 \text{ m s}^{-1}$  in 12 s.

(a) Calculate the acceleration of the car.

acceleration = ..... [2]

(b) Calculate the force needed to give this acceleration.

force = ..... [2]

(c) At a speed of 40 m/s, the driving force is 5500 N and the car travels 350 m at this speed.

(i) Calculate the work done by the driving force on the car.

work done = ..... [2]

(ii) Determine the frictional force acting on the car for this 350 m.

frictional force = ..... [1]

- 2 Fig. 2.1 shows a ball of weight 80 N hanging in equilibrium from a string that is pulled to one side by a horizontal force  $F$  of magnitude 60 N

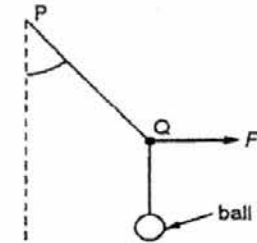

Fig. 2.1

- (a) In the space below, draw a vector diagram to determine the resultant of  $F$  and the weight of the ball. State clearly the scale that you have used.

scale = .....

magnitude of resultant force = ..... [3]

- (b) State the direction of the resultant force with respect to force  $F$ .

direction = ..... [1]

- 3 Fig. 3.1 shows a skier of mass 85 kg skiing down a very steep slope.

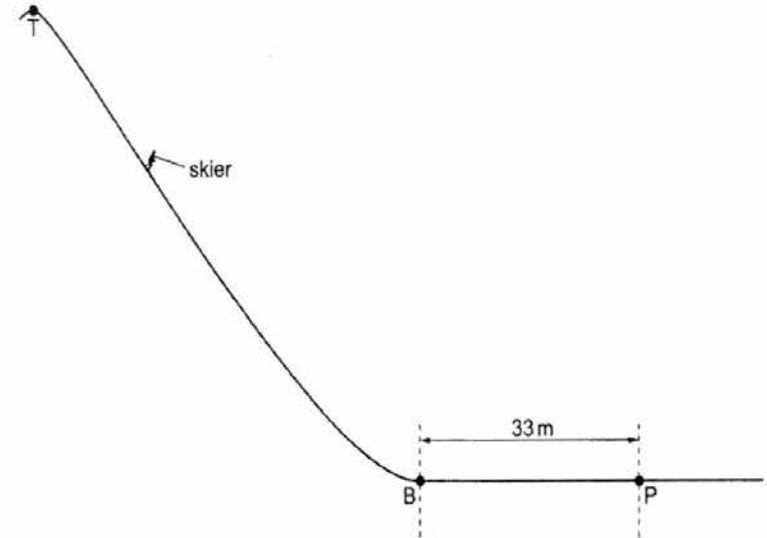

Fig. 3.1 (not to scale)

The skier starts from rest at the top **T** of the slope. The force of gravity accelerates him down the slope. When he reaches the bottom **B** of the slope, his kinetic energy is  $5.5 \times 10^4$  J.

- (a) The gravitational field strength is 10 N/kg. Calculate

- (i) the weight of the skier,

weight = ..... [1]

- (ii) the minimum possible difference in height between **T** and **B**.

height difference = ..... [2]

- 3 (b) At **B**, the skier digs into the snow and stops at point **P** after travelling 33 m horizontally. Calculate the average horizontal force that acts on the skier between **B** and **P**.

force = ..... [2]

- 4 Fig. 4.1 shows food being cooked in an electric grill.

red-hot heating elements

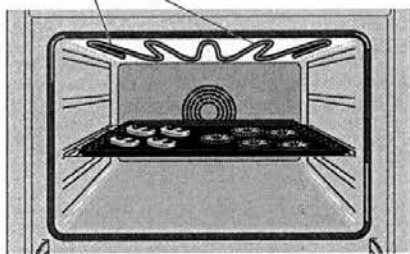

Fig. 4.1

There are red-hot heating elements above the food and thermal energy is transmitted to the food by radiation.

- (a) Explain what is meant, in this case, by *radiation*.  
 ..... [1]
- (b) Explain why little thermal energy is transmitted to the food by  
 (i) conduction,  
 ..... [1]
- (ii) convection.  
 ..... [1]

- 5 A light source emitting red light is placed in water as shown in Fig. 5.1. The laser is incident on the water-air interface, making an angle of  $35^\circ$  with the water surface. The refractive index of water is 1.3.

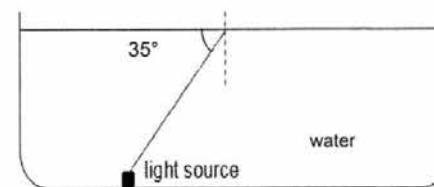

Fig 5.1

- (a) Calculate the critical angle of water.

critical angle = ..... [2]

- (b) On Fig. 5.1, draw the light ray after it hits the water-air interface. [1]
- (c) Explain why the light ray travels in the direction indicated in part (b).  
 ..... [2]

6 Fig. 6.1 shows the displacement-time graphs for sound waves produced by three different sources A, B and C.

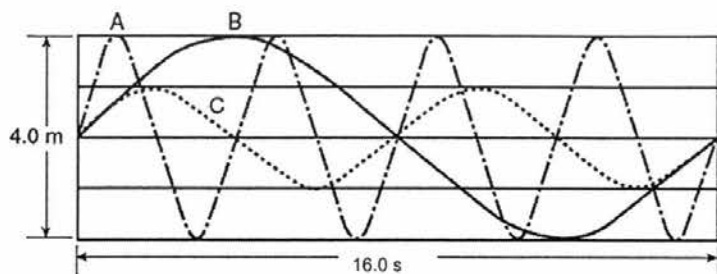

Fig. 6.1

(a) State the amplitude of sound wave produced by source C.

amplitude = .....[1]

(b) Calculate the frequency of the sound wave produced by source A.

frequency = .....[2]

(c) Compare the sound waves produced by sources A and B in terms of pitch and loudness.

.....  
 .....  
 .....  
 .....[2]

7 In Fig. 7.1, instruments on a ship send out an ultrasonic sound wave at a certain frequency and detects an echo from the sea bed exactly 6.0 s later. The water is 4500 m deep.

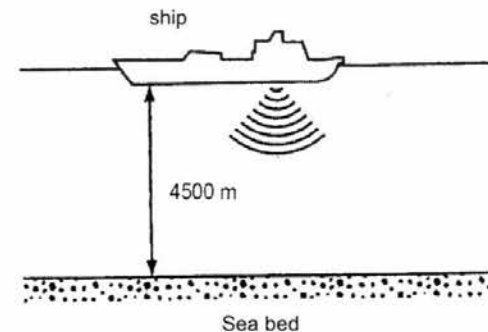

Fig. 7.1

(a) Describe how sound waves are transmitted through sea water.

.....  
 .....  
 .....[2]

(b) Calculate the speed of sound in the sea water.

speed of sound in sea water = ..... [2]

(c) Given that the frequency of the sound is 250 Hz, calculate the wavelength of the sound in sea water.

wavelength of sound in sea water: ..... [2]

8 Fig. 8.1 shows a part of a device called a gold leaf electroscope. The plate, rod and leaf are all made of metal. Fig. 8.2 shows what happens to the gold leaf when a positively charged strip is held close to the plate.

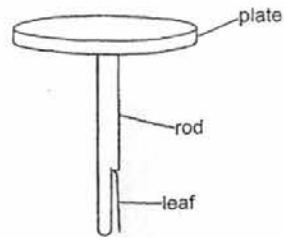

Fig 8.1

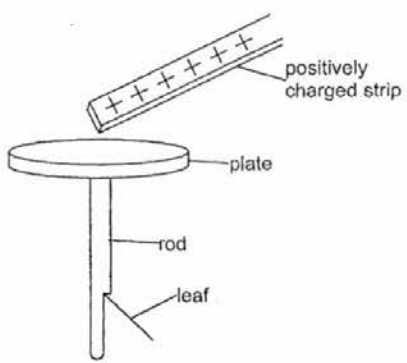

Fig 8.2

- (a) State the nature of the charge at the plate in Fig 8.2 .....[1]  
 (b) Explain why the leaf moves away from the rod in Fig 8.2.

.....  
 .....  
 .....  
 .....  
 .....  
 .....[3]

9 Fig. 9.1 shows a workman using a cordless electric drill.



Fig. 9.1

The motor of the drill is powered by a rechargeable battery with an electromotive force (e.m.f.) of 24 V. When the drill is used, the power supplied to the motor is 450 W.

- (a) Calculate the operating current of the power drill.

operating current = ..... [2]

- (b) The workman uses the drill for two hours. The cost of electricity is \$0.20 per kWh

Calculate

- (i) the electrical energy supplied to the motor, expressing your answer in joules

energy = ..... [2]

- (ii) the cost of electricity during the usage of the drill for 2 hours

cost of electricity = ..... [2]

**Section B [20 Marks]**  
 Answer **two** out of three questions.  
 Write your answers in the spaces provided.

- 10 Fig. 10.1 shows a diving-board at a swimming pool. The diving board is of negligible mass and is pivoted at P. A diver of weight 600 N stands at a point 1.5 m from P as shown. A spring S holds the diving board in a horizontal position. The distance between the spring S and the pivot P is 0.3 m.

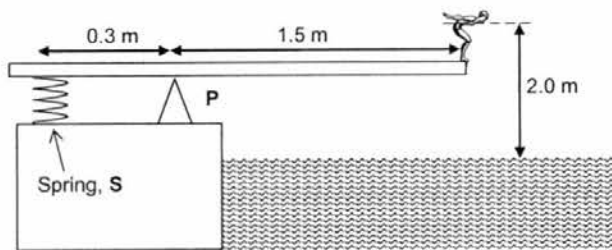

Fig. 10.1

- (a) State the *principle of moments*.

.....  
 .....  
 ..... [1]

- (b) Calculate the moment of the weight of the diver about the pivot P.

moment = ..... [1]

- (c) Calculate force on the spring which will hold diving board in horizontal position when the diver is at the edge of the diving board.

force on spring = ..... [2]

- 10 As the diver stands on the edge, both feet are in full contact with the board. The area of each foot in contact with the board is  $0.025 \text{ m}^2$ .
- (d) Calculate the pressure exerted by the diver on the diving board.

pressure = ..... [2]

When the diver enters the water,  $0.061 \text{ m}^3$  of water is displaced from the swimming pool.

- (e) State what is meant by the *mass* of a body.

.....  
 ..... [1]

- (f) Calculate the average density of the diver. Take  $g = 10 \text{ N/kg}$

density = ..... [3]

- 11 The diagram below shows a circuit.

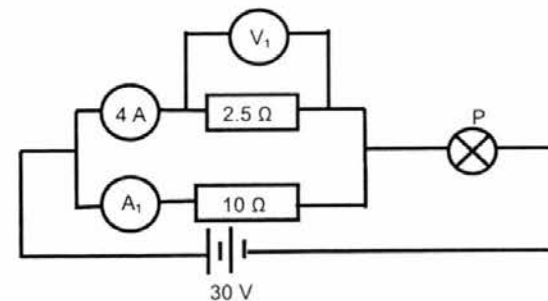

- (a) Calculate the reading of the voltmeter  $V_1$ .

reading of voltmeter  $V_1$  = ..... [2]

11 (b) Calculate the value of  $A_1$ .

$A_1 = \dots\dots\dots [1]$

(c) Calculate the resistance of light bulb P.

resistance of resistor P =  $\dots\dots\dots [2]$

(d) Calculate the overall resistance of the circuit.

resistance of the circuit =  $\dots\dots\dots [2]$

(e) Calculate the power dissipated from the  $2.5 \Omega$  resistor.

power =  $\dots\dots\dots [2]$

(f) The  $10 \Omega$  resistor is now replaced with a  $2.5 \Omega$  resistor. State and explain how this affects the brightness of the light bulb P (if any).

$\dots\dots\dots [1]$

12 (a) A student sets up the apparatus as shown in Fig. 12.1 to demonstrate how a door bell works.

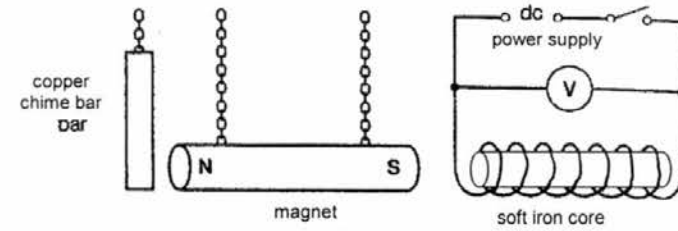

Fig. 12.1

(i) On Fig. 11.1, mark the positive terminal of the dc power supply with letter 'P' such that the magnet will hit the copper chime bar when the switch is closed. [1]

(ii) Explain why the magnet hits the copper chime bar when the switch is closed.

$\dots\dots\dots [2]$

(iii) Describe and explain what happens to the magnet when the switch is opened.

$\dots\dots\dots [2]$

(iv) The direct current power supply is now replaced with alternating current power supply. Describe what will happen to the magnet when the switch is closed.

$\dots\dots\dots [2]$

- 12 (b) An aluminium wire is placed between the poles of a magnet. It is rested on two wooden blocks which stand on a balance as shown in Fig.12.2.

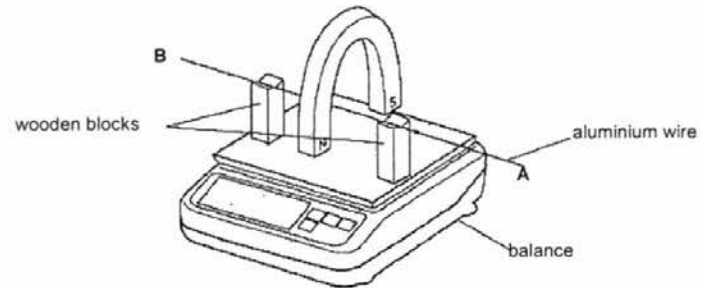

Fig. 12.2

- (i) On Fig. 12.3, draw the magnetic field lines around the aluminium wire when the current flows from point A to B. [1]

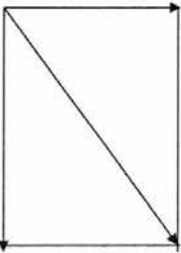

Fig. 12.3

- (ii) State and explain the change in the balance reading when the current flows from point A to B.

.....  
.....  
.....  
.....  
.....[2]

END OF PAPER

Section A		Teacher's remarks
1(a)	$a = \frac{30}{12}$ [M1] $= 2.5 \text{ ms}^{-2}$ [A1]	
1(b)	$F = ma$ [M1] $= 1400 \times 2.5$ $= 3500 \text{ N}$ [A1]	
1(c)	Work done = $5500 \times 350$ $= 1925 \text{ 000 J}$ [A1]	
1(cii)	Frictional force = $5500 \text{ N}$ [B1]	
2	(a)   drawing [1] Scale = $1 : 10 \text{ N}$ [B1] Magnitude = $10 \text{ N} \pm 1 \text{ N}$ [B1]  (b) Resultant is $54^\circ$ clockwise to Force F [B1]	
3(ai)	$W = mg = 85 \times 10 = 850 \text{ N}$ [B1]	
3(aii)	$mgh = 5.5 \times 10^4$ [M1] $h = \frac{5.5 \times 10^4}{85 \times 10}$ $= 64.7 \text{ m}$ [A1]	
3(b)	Work done = $F \times d = 5500$ [M1] $F = 1670 \text{ N}$ [A1]	
4(a)	Radiation is the transfer of heat without the use of medium in the form of electromagnetic waves [B1]	
4(b)	<b>Air is a poor conductor of heat</b> [B1]	
4(bii)	Air near heating element is on <b>top of food and will not sink as it is less dense</b> . Hence no convection current is set up [B1]	
5 (a)	$\text{sinc} = \frac{1}{n} = \frac{1}{1.3}$ [M1]	

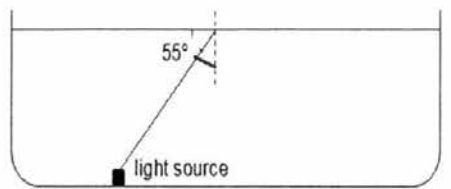
	$= 0.769$ $C = 50.3^\circ$ [A1]	
5 (b)		
5 (c)	The angle of incidence at the water-air boundary is <b>more than the critical angle</b> . [B1] Hence it undergoes <b>total internal reflection</b> [B1] [1]	
6 (a)	Amplitude = $1.0 \text{ m}$ [B1]	
6 (b)	$T = 4 \text{ s}$ [M1] $f = 1/T = \frac{1}{4} = 0.25 \text{ Hz}$ [A1]	
6 (c)	Sources A and B have the same loudness. [B1] Source A has a higher pitch than source B. [B1]	
7(a)	Sound waves travel in the form of longitudinal waves [B1] with a series of compressions and rarefactions of water particles. [B1]	
7(b)	$v = \frac{2d}{t} = \frac{9000}{6}$ [M1] $= 1500 \text{ m/s}$ [A1]	
7 (c)	$v = f\lambda$ $\lambda = \frac{1500}{250}$ [M1] $= 6 \text{ m}$ [A1]	
8(a)	Negative [B1]	
8(b)	<b>Electrons are attracted to the positively charged rod</b> [B1] leaving the <b>bottom end of the rod and leaf positive charged</b> . [B1] Since <b>bottom end of rod and leaf are of the same charge, they repel</b> [B1]	
9 (a)	$I = 450/24$ [M1] $= 18.75 \text{ A}$ [A1]	
9 (b)	$E = Pt$ $= 450 \times 2 \times 3600$ [M1] $= 3240 \text{ 000 J}$ [A1]	
9(c)	$E = 2 \times 0.45 = 0.9 \text{ kWh}$ [M1] Cost = $0.9 \times \$0.20 = \$0.18$ [A1]	
Section B		
10 (a)	When a body is equilibrium, the sum of clockwise momentss about the pivot is equal to the sum of anti-clockwise moments about the same pivot. [B1]	

10 (b)	Moment = $600 \times 1.5$ = 900 Nm [A1]	
10 (c)	$F \times 0.3 = 900$ [M1] $F = 900/0.3 = 3000$ N [A1]	
10(d)	$P = \frac{F}{A} = \frac{600}{0.05}$ [M1] = 12000 Pa [A1]	
10(d)	Mass of a body is the amount of matter in a body [B1]	
10 e	$\rho = \frac{m}{v}$ [M1] = $\frac{60}{0.061}$ [M1] = 983 kg/ m <sup>3</sup> [A1]	
11 a	$V = IR$ = $4 \times 2.5$ [M1] = 10 V [A1]	
11 (b)	$A1 = \frac{10}{10} = 1$ A [A1]	
11 (c)	$R = \frac{V}{I} = \frac{20}{5}$ = 4 $\Omega$ [A1]	
11 (d)	For parallel connections $\frac{1}{R} = \frac{1}{2.5} + \frac{1}{10}$ = $\frac{12.5}{25}$ R = 2 $\Omega$ [M1]  R Total = 2 + 4 = 6 $\Omega$ [A1]	
11 (e)	$P = I^2R = 16 \times 2.5$ [M1] = 40 W [A1]	
11 (f)	The resistance of the parallel branch decreases. Hence current increases and light bulb P becomes brighter.[B1]	
12 (aii)	<b>Left side</b> of iron core is the <b>South pole</b> . [B1] Hence it <b>repels the magnet</b> and it hits the copper chime bar. [B1]	
12 (aiii)	The soft iron bar <b>de-magnetises</b> [B1] Magnet now <b>attracts</b> the soft iron core. [B1]	
12 (aiv)	The soft iron core alternates between being North and South pole. Hence the magnet oscillates giving rise to a continuous chime. [B1]	

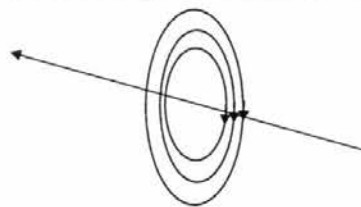
12 (bi)		
	[1]	
12 (bii)	Using Fleming's Left Hand rule, force acts <b>downwards</b> on [B1] conductor. This casues an increase in balance reading. [B1]	