

Visit

[FreeTestPaper.com](http://FreeTestPaper.com)

for more papers

NAME	CLASS	INDEX NO.
------	-------	-----------



**ST. PATRICK'S SCHOOL  
PRELIMINARY EXAMINATIONS 2016**

SUBJECT : SCIENCE  
(PHYSICS/CHEMISTRY) 5076  
PAPER 1

DATE : 30 Aug 2016

LEVEL : SECONDARY 4 EXPRESS /  
5 NORMAL (ACADEMIC)

DURATION : 1 HOUR

**INSTRUCTIONS TO CANDIDATES**

**DO NOT OPEN THIS BOOKLET UNTIL YOU ARE TOLD TO DO SO.**

- Write your name, class and index number on the **Question Paper** and the OAS sheet provided. Shade your register number clearly on the OAS sheet.
- There are 40 questions in this paper. Answer **all** questions.
- Calculators may be used where necessary.

**For Examiner's Use Only**

	<b>Total (40 m)</b>
Score	

Teacher's comments (if any): \_\_\_\_\_

Parent's / Guardian's Signature: \_\_\_\_\_ Date: \_\_\_\_\_

*This question paper consists of 19 printed pages including Data Sheet & Periodic Table.*

**Answer all questions. Shade your answers in the OAS sheet provided.**

- A pair of vernier calipers is used to measure the total length of 5 coins placed side by side.

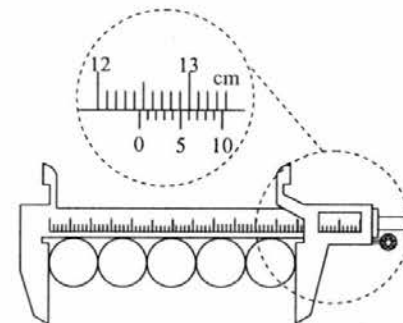

What is the diameter of one coin?

- |                  |                  |
|------------------|------------------|
| <b>A</b> 2.45 cm | <b>B</b> 2.49 cm |
| <b>C</b> 2.59 cm | <b>D</b> 2.95 cm |

- An object at rest falls from a 15 m tall building. Assuming negligible air resistance, which speed-time graph correctly displays the motion of this object?

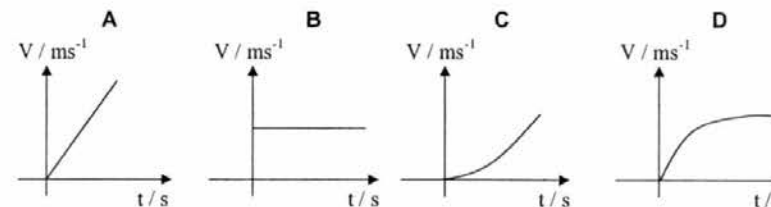

- 3 The figure shows a hydraulic system in which a 20 kg object is balanced by a 50 kg object. The areas of the small and large pistons are  $A_1$  and  $A_2$  respectively. What is the ratio  $A_1 : A_2$ ?

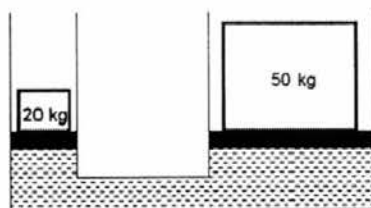

- A 2 : 5                                      B 5 : 2  
 C  $\sqrt{2} : \sqrt{5}$                                 D  $\sqrt{5} : \sqrt{2}$

- 4 A lump of stone is weighed using a newton-meter (spring balance) and a pair of scales. This experiment is repeated on the Moon. Are the readings for each balance the same or different when taken on Earth and on the Moon?

	on newton-meter	on scales
A	different	same
B	different	different
C	same	different
D	same	same

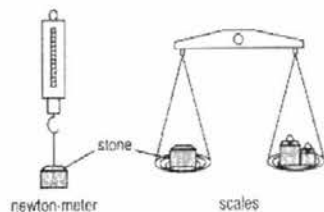

- 5 The density of a metal bar is  $12.0 \text{ g/cm}^3$ . It has a mass of 36 g. When a hole of volume  $1.0 \text{ cm}^3$  is drilled into the bar, what will its density be?

- A  $6.0 \text{ g/cm}^3$                                       B  $12.0 \text{ g/cm}^3$   
 C  $12.5 \text{ g/cm}^3$                                     D  $18.0 \text{ g/cm}^3$

- 6 The diagrams show the cross-sections of different glasses. Which one is the least stable when filled with a liquid?

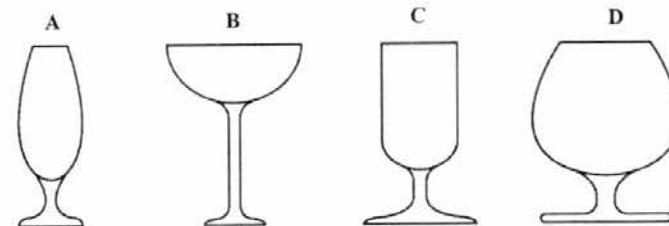

- 7 The diagram below represents a hydroelectric power station which generates electricity.

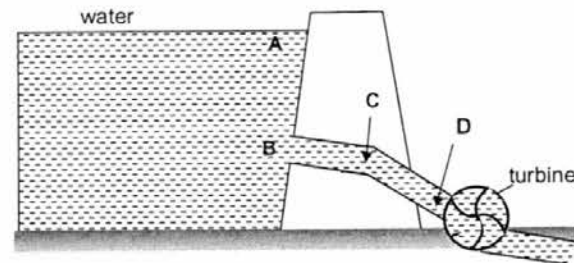

At which position A, B, C or D is the kinetic energy of the water greatest?

- 8 A liquid of the same volume as a solid expands faster when heated.

Which of the following statement is correct?

- A The liquid molecules are bigger.  
 B The liquid molecules expand faster.  
 C The forces between liquid molecules are weaker than those between the molecules in the solid.  
 D The liquid molecules collide more frequently with each other.

- 9 A solid substance is placed in an open can and is being heated steadily. Its temperature is recorded at different intervals and the results are shown in the temperature-time graph below. At which interval is the substance purely a liquid?

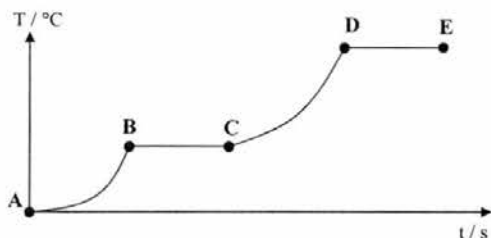

- A AB  
B BC  
C CD  
D DE

- 10 A substance consists of particles that are close together and moving past each other at random. The average speed of the particles is gradually increasing. What best describes the substance?

- A A gas being heated.  
B A liquid being heated.  
C A solid being heated.  
D A solid being melted.

- 11 The diagram below shows a plane mirror placed at a distance of 400 cm in front of a man.

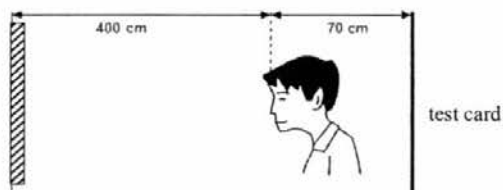

If the doctor's test card is fixed at 70 cm behind the eyes of the man, what is the distance of the image of the test card from the man?

- A 470 cm    B 800 cm    C 870 cm    D 940 cm

- 12 When an object is placed 15 cm in front of a convex lens, the image is formed 30 cm behind the lens.

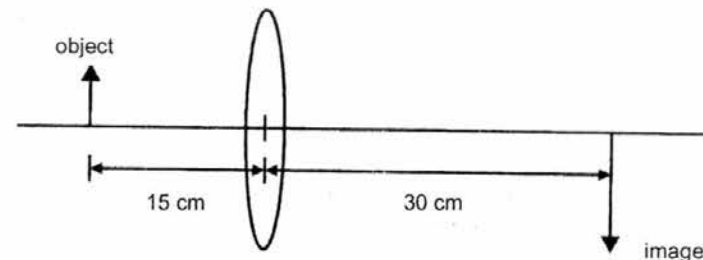

How would the size of the image and the image distance change when the object is moved slightly nearer to the lens?

	size of image	image distance
A	decrease	decrease
B	decrease	increase
C	increase	decrease
D	increase	increase

- 13 The diagrams show sound waves on an oscilloscope. Which diagram represents the quietest sound with the highest frequency?

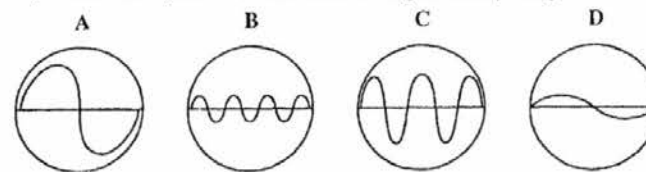

- 14 A 1 m wire of radius,  $r$  has a resistance of  $10 \Omega$ . If another similar wire, twice the length but with radius  $0.5r$  is used, what is the new resistance of the wire?

- A  $5 \Omega$   
B  $10 \Omega$   
C  $40 \Omega$   
D  $80 \Omega$

- 15 The voltage-current graphs for four electrical devices are shown. Which graph shows the resistance increasing as the current increases?

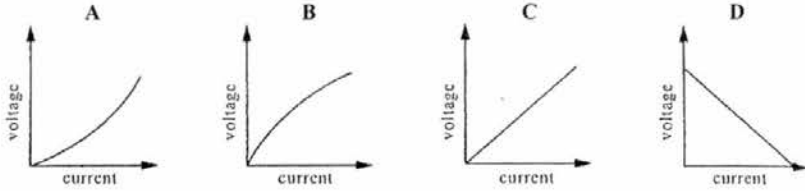

- 16 Which of the following appliances would cost the most if operated from the same voltage supply?

- A An electric cooker of 5000 W being used for 1 minute
- B An electric fire of 1000 W being used for 10 minutes
- C An electric iron of 500 W being used for 1 hour
- D A study lamp of 100 W being used for 1 day

- 17 Three identical heating elements are wired up to the mains supply in three separate arrangements shown in the diagram below.

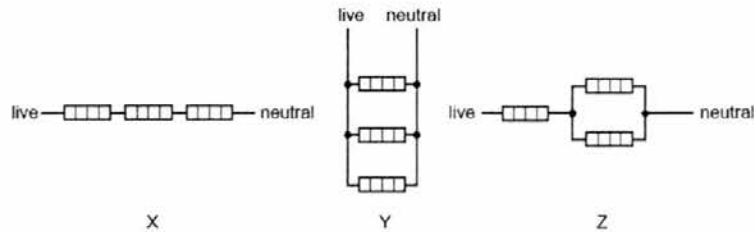

In which arrangement is the current from the mains supply the lowest and in which is it the highest?

	lowest current	highest current
A	X	Z
B	X	Y
C	Y	X
D	Y	Z

- 18 Which diagram shows the correct connections for a switch and lamp in a lighting circuit?

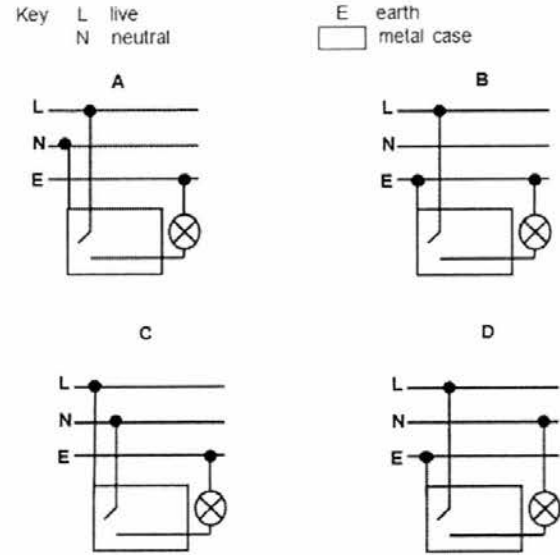

- 19 Four plotting compasses are placed in the magnetic field of two bar magnets as shown in the diagram below. One of them is pointing in the wrong direction. Which one is it?

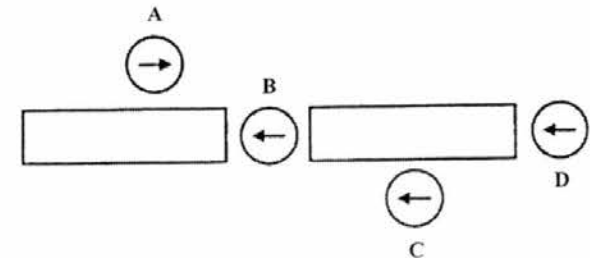

20 The diagram shows a beam of electrons entering a magnetic field.

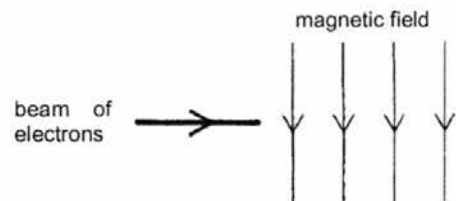

What is the effect of the magnetic field on the electrons?

- A They are deflected into the plane of the diagram.
- B They are deflected out of the plane of the diagram.
- C They are deflected towards the bottom of the diagram.
- D They are deflected towards the top of the diagram.

NAME	CLASS	INDEX NO.
------	-------	-----------



**ST. PATRICK'S SCHOOL  
PRELIMINARY EXAMINATIONS 2016**

SUBJECT : SCIENCE (PHYSICS)  
5076 PAPER 2

DATE : 23 AUG 2016

LEVEL : SECONDARY 4 EXPRESS /  
5 NORMAL (ACADEMIC)

DURATION : 1 HOUR 15 MIN

INSTRUCTIONS TO CANDIDATES

DO NOT OPEN THIS BOOKLET UNTIL YOU ARE TOLD TO DO SO.

1. Write your name, class and class index number at the top of this page and on any writing paper used.
2. For Section A : Answer ALL questions. Write your answers in the spaces provided.
3. For Section B : Answer ANY 2 questions in the spaces provided.
4. DO NOT DETACH any sections from this paper.

INFORMATION FOR CANDIDATES

The number of marks is given in brackets [ ] at the end of each question or part question. Candidates are reminded that ALL quantitative answers should include appropriate units. Candidates are advised to show all their working in a clear and orderly manner, as more marks are awarded for sound use of physics than for correct answers. Calculators may be used where necessary. Throughout the paper, you are to take the acceleration due to gravity on Earth to be  $10 \text{ m/s}^2$  unless stated otherwise.

For Examiner's Use Only

Section	A (45 m)	B (20 m)	Total (65 m)	100%	Grade	Target Grade
Score						

Parent's / Guardian's Signature : \_\_\_\_\_

This question paper consists of 16 printed pages including this cover page.

**SECTION A : [45 marks]**

Answer ALL questions in this section. Show your working and write your answers in the space provided.

- 1 The figure shows how the speed of a vehicle changes during part of a journey.

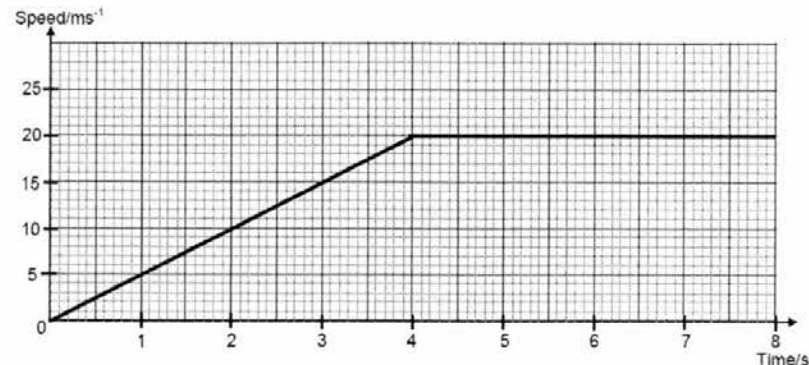

- (a) Calculate the acceleration of the vehicle from 0 s to 2 s.

acceleration = .....  $\text{m/s}^2$  [2]

- (b) Calculate the average speed of the vehicle for the whole journey.

Average speed = .....  $\text{m/s}$  [2]

2 The figure below shows a stone supported by two strings that hang from a rod.

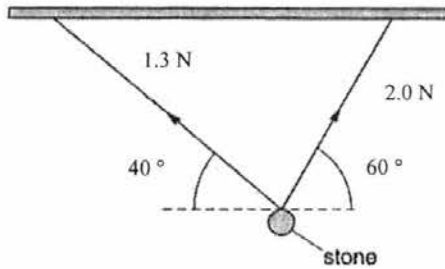

The tensions in the two strings are 1.3 N and 2.0 N.

In the space below, draw a labelled diagram to show the resultant of the two tensions. Determine the size of the resultant force and the angle between the resultant force and the horizontal. [4]

Scale = .....

Resultant force = .....

Angle = .....

3 The diagram below shows a pivoted light beam (of negligible weight) with two weights hanging from it.

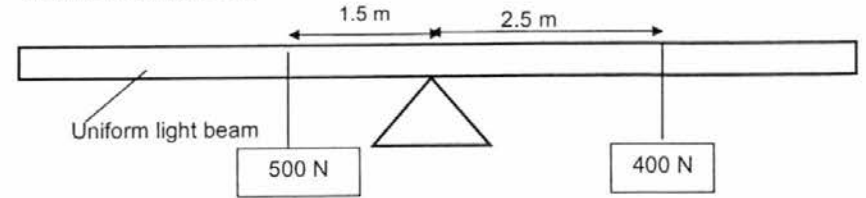

(a) Calculate the clockwise and anti-clockwise moments about the pivot. [2]

Clockwise moment = .....

Anticlockwise moment = .....

(b) From your answer in (a), explain why the beam would not stay horizontal. Hence, state the direction of the turn of the beam. [2]

.....  
 .....  
 .....

(c) Draw with an arrow on the above diagram the **position** and **direction** of a 250 N force that can be applied to balance the beam. [1]

4 "Travelling at the speed of light, the ultraviolet and x-ray energies of the solar flare make the 93 million-mile trip to Earth in eight minutes. Some flares also hurl high-energy protons, which reach us in 15 minutes to an hour."

(a) Two electromagnetic waves are mentioned in the above news excerpt. State another electromagnetic wave which has a frequency higher than both of the two mentioned.

..... [1]

(b) State one application of ultraviolet light.

..... [1]

(c) One of the properties of electromagnetic waves is they travel in vacuum at the speed of light of  $3.0 \times 10^8$  m/s.

(i) State another two properties of electromagnetic waves.

.....  
 .....  
 ..... [2]

(ii) Given that the x-ray used has a wavelength of 3.0 nm, calculate the frequency of the x-ray.

frequency = ..... Hz [2]

5 The figure below (not drawn to scale) shows an incident ray at point P on the surface of a right angled glass prism.

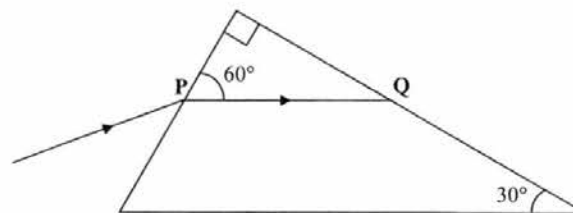

(a) The refractive index of the glass prism is 1.53. Determine the angle of incidence at point P.

angle of incidence = ..... [2]

(b) Determine the critical angle of glass.

Critical angle = ..... [2]

(c) On the figure, complete the path of the light after it reaches point Q. Ensure all angles are properly labelled. [1]

- 6 A sound wave is emitted downwards from a ship as shown in the figure below. The wave is reflected by the seabed back to the ship. The wave takes 0.25 s to travel to the seabed and back to the ship. The seabed is 180 m below the ship.

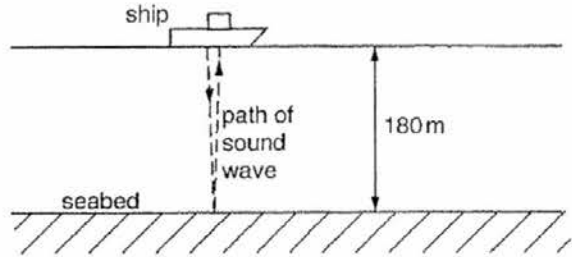

- (a) Calculate the speed of sound in seawater.

speed = ..... m/s [2]

- (b) (i) Explain why sound travels faster in water than in air.

.....  
 ..... [1]

- (ii) There was a point when the time taken to register the return signal became shorter. Suggest a reason for this.

.....  
 ..... [1]

- (c) Suggest why sound waves cannot travel from the earth to the moon.

..... [1]

- 7 (a) In an experiment, Angela rubs one side of an inflated balloon on her hair. This side of the balloon becomes negatively charged. Explain why this is so.

.....  
 ..... [1]

- (b) Angela repeated the experiment by holding a metal sphere and rubbing one side of it against her hair. The metal sphere did not become charged. Explain why this is so.

.....  
 ..... [1]

- 8 (a) The figure below shows a battery of electromotive force 6.0 V connected to a resistor and a light bulb. The potential difference across the light bulb is 1.5 V.

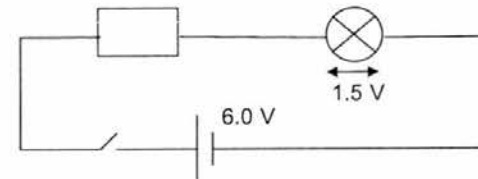

- (i) What is meant by the *electromotive force* of the battery is 6.0 V?

..... [1]

- (ii) Explain why the potential difference across the resistor has a value of 4.5 V?

..... [1]

- (b) (i) Calculate the charge that passes through the bulb when a current of 2.0 A flows through it for 5 minutes.

charge = .....C [2]

- (ii) Calculate the amount of electrical energy that is converted into heat and light in the bulb.

electrical energy = .....J [2]

- (c) The figure below shows three identical electric lamps **A**, **B** and **C** connected to a 240 V mains supply. Each lamp lights up normally at its normal brightness only if the potential difference across it is 240 V.

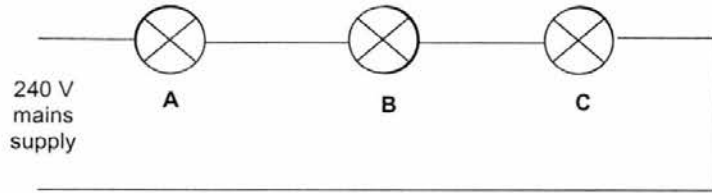

When the mains supply is switched on, current flows in the circuit but the lamps do not light up to their normal brightness. Explain this observation.

.....  
 .....  
 ..... [2]

- 9 An electric kettle designed to be operated from a 240 V supply has a power rating of 1.68 kW.

- (a) Calculate the size of the current when the kettle is being used.

Current = ..... A [2]

- (b) Suggest a suitable rating for a fuse to be used with this kettle from the following available fuses: 5 A, 10 A and 13 A.

..... [1]

- (c) In the normal operation of the electric kettle, write down the size of the current in:

- (i) the live wire, ..... A [1]  
 (ii) the earth wire, ..... A [1]  
 (iii) the neutral wire, ..... A [1]

**SECTION B : [20 marks]**

Answer **any 2** questions. Show your working and write your answers in the spaces provided.

- 1 A falling hammer is used to drive a hollow steel post into the ground, as shown in the figure below. The hammer is lifted by an electric motor and then falls freely to hit the base plate.

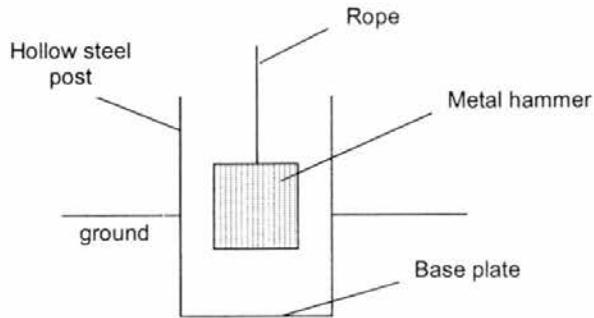

- (a) (i) State the law of conservation of energy.  
 .....  
 .....  
 .....[2]
- (ii) State the energy conversions that take place as the hammer falls, starting from initial potential energy of the hammer before it is dropped.  
 .....[1]
- (b) The metal hammer has a volume of  $0.45 \text{ m}^3$  and a density of  $3300 \text{ kg/m}^3$ . The hammer hits the baseplate with a speed of  $8 \text{ m/s}$ . Assume  $g$  to be  $10 \text{ N/kg}$ .
- (i) What is the mass of the metal hammer?

Mass = ..... [2]

- (ii) What is the weight of the metal hammer?

Weight = ..... [1]

- (iii) Calculate the kinetic energy of the hammer as it hits the base plate.

Kinetic energy = ..... [2]

- (iv) Calculate the height above the base plate from which the hammer is dropped.

Height = ..... [2]

- 2 The figure below shows the structure of a solar water heating system that uses liquid as a heating fluid. The fluid is a mixture of water and propylene glycol. Water in copper pipes is heated by solar radiation. The hot water in the copper pipes is then used to heat cold water in a tank.

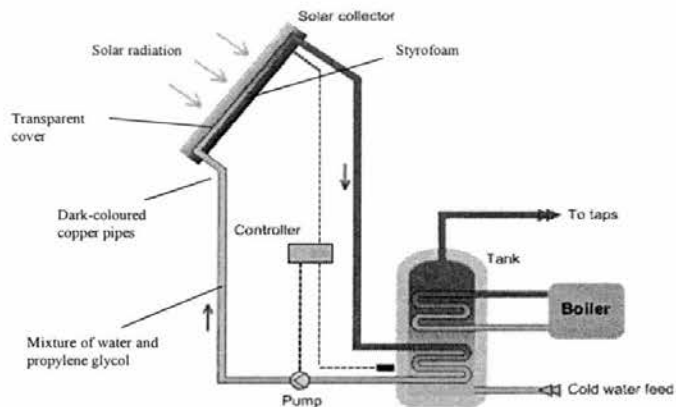

- (a) Explain the purpose of the

(i) Styrofoam backing board.

.....  
 ..... [2]

(ii) dark-coloured copper pipes.

.....  
 ..... [2]

- (b) Describe, at the molecular level, how solar energy is transferred to the fluid through the copper pipes in the solar water heating system.

.....  
 .....  
 .....  
 ..... [3]

- (c) Explain why the cold water feed is at the bottom of the water tank while the hot water tap is at the top of the water tank.

.....  
 ..... [2]

- (d) The fluid used in the solar water heating system, which is a mixture of water and propylene glycol, has a lower freezing point than pure water.

Suggest a reason why a fluid with low freezing point is important.

.....  
 ..... [1]

3 (a) The figure below shows a motor.

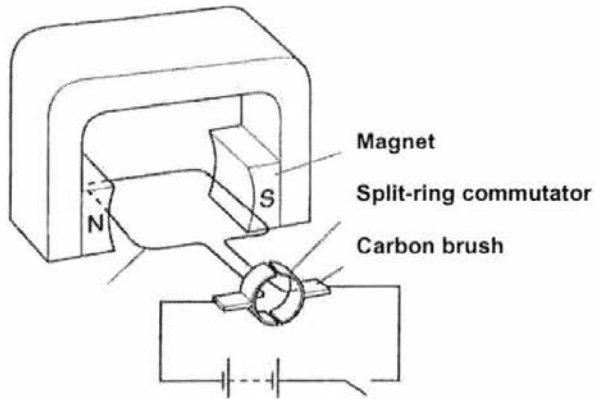

(i) On the diagram above draw arrows to show the directions of the forces acting on the sides of the coil. [2]

(ii) Explain why the coil turns when the switch is closed.

.....

.....

.....

[2]

(iii) State two ways to make the coil turns faster.

.....

.....

.....

[2]

(b) The figure below shows a soft iron coiled with wire and connected to a battery. There are some iron paper clips placed near the bottom of the soft iron.

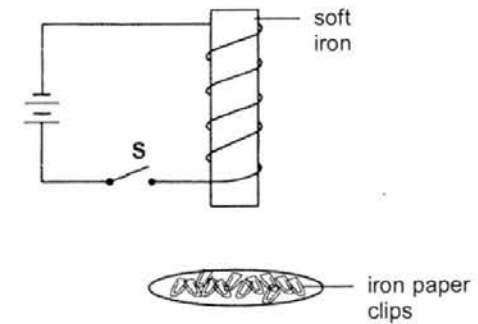

(i) State what happens to the paper clips when the switch **S** is closed and opened.

.....

.....

[2]

(ii) The soft iron in is replaced with a steel rod. State and explain what would be the difference from **b(i)** if the switch **S** is closed and then opened.

.....

.....

[2]

END OF PAPER

## 4E5N Sci(phy) 2016 ANSWER SCHEME

## PAPER 1

1	2	3	4	5	6	7	8	9	10
B	A	A	A	B	B	D	C	C	B
11	12	13	14	15	16	17	18	19	20
C	D	B	D	A	D	B	D	C	B

## PAPER 2

## Section A [45 MARKS]

- 1 (a)  $a = \frac{v-u}{t} = \frac{10-0}{2-0} = 5 \text{ m/s}^2$  [1]  
[1]
- (b)  $D = 4 \times 20 + \frac{1}{2} \times 4 \times 20 = 120 \text{ m}$  [1]  
Ave speed =  $120/8 = 15 \text{ m/s}$  [1]
- 2 *Scale = 1 cm : 0.333 N or smaller* [1]  
*Angles between 2.0 N force and 1.3 N force correct* [1]  
*Method correct with resultant force drawn correctly* [1]  
Resultant force = 2.57 N ( 2.40 N to 2.80 N) accept 2 s.f. [1]  
Angle =  $90^\circ (\pm 1^\circ)$  [1]  
\*missing arrows = -1 mark
- 3 (a) Clockwise moment =  $400 \times 2.5 = 1000 \text{ Nm}$  [1]  
Anticlockwise moment =  $500 \times 1.5 = 750 \text{ Nm}$  [1]
- (b) The clockwise moment is not equal to the anti-clockwise moment. [1]  
The beam will turn clockwise. [1]
- (c) Position: 1m to the left of pivot [1]  
Direction: Downwards [1]  
OR  
Position: 1m to the right of pivot [1]  
Direction: Upwards [1]
- 4 (a) Gamma ray [1]  
(b) Sun bed, Sterilisation (Any one reasonable application) [1]  
(c) (i) EM waves are transverse waves. [1]  
EM waves do not need medium to travel through. [2]  
(ii)  $3 \times 10^8 = f \times 3 \times 10^{-9}$  [1]  
 $f = 1.0 \times 10^{17} \text{ Hz}$  [1]
- 5 (a)  $\frac{\sin i}{\sin r} = 1.53$  [1]  
 $\frac{\sin i}{\sin 30} = 1.53$  [1]  
 $i = 50.0^\circ$  [1]  
(b)  $\sin c = 1/1.53$  [1]  
 $C = 40.8$  [1]  
(c) TIR occurs at Q. Angle I at Q =  $60^\circ > C$  [1]
- 6 (a) speed = distance / time =  $2 \times 180 / 0.25 = 1440 \text{ m/s}$  [1]  
[1]
- (b) (i) The molecules in water are closer to one another than in air. [1]  
(ii) The sound wave could have hit an underwater object before reaching the seabed. [1]
- (c) There is no medium of transmission necessary for sound to travel. [1]
- 7 (a) The side of balloon becomes negatively charged because it has gained negatively charged electrons from Angela's hair from friction by rubbing. [1]
- (b) Metal sphere is a good conductor of electricity so it is not easily charged by friction. The extra electrons gained can easily escape through Angela's hands to the ground. [1]
- 8 (ai) 6 J of energy is needed to drive 1 C of electric charge round the circuit OR 6J of chemical potential energy from the battery is converted to electrical energy in the resistor and light bulb when 1 C of charge flows round the circuit. [1]
- (aii) Since energy cannot be created nor destroyed, the chemical potential energy from the battery must be equal to the energy converted in light bulb and resistor. [1]
- (bi)  $Q = It = 2 \text{ A} \times 300 \text{ s} = 600 \text{ C}$  [1]  
[1]
- (bii)  $E = QV = 1.5 \text{ V} \times 600 \text{ C} = 900 \text{ J}$  [1]  
[1]
- (ci) Since the lamps are connected in series, Potential difference across each lamp is only 80 V. [1]  
[1]
- 9 (a) current = power / voltage =  $1680 / 240 = 7 \text{ A}$  [1]  
[1]
- (b) 10 A fuse [1]
- (c) (i) live wire - 7 A [1]  
(ii) earth wire - 0 A [1]  
(iii) Neutral - 7 A [1]
- 1 (a) (i) Energy cannot be created nor can it be destroyed but it can be converted from one form to another. [1]  
[1]
- (ii) Potential energy  $\xrightarrow{[1/2]}$  Kinetic energy  $\xrightarrow{[1/2]}$  Sound energy
- (b) (i) Density = mass/ volume  
Mass =  $0.45 \times 3300 = 1485 \text{ kg}$  [1]  
[1]
- (ii) Weight = mg  
=  $1485 \times 10 = 14850 \text{ N}$  [1]
- (iii) K.E. =  $\frac{1}{2} mv^2 = \frac{1}{2} \times 1485 \times 8 \times 8 = 47520 \text{ J}$  [1]  
[1]

- (iv) K.E. at the bottom = P.E. at the top  
 $47\,520 = 1485 \times 10 \times h$   
 $h = 3.2 \text{ m}$  [1]  
[1]
- 2 (a)(i) Air is trapped inside styrofoam, and it is a bad conductor. [1]  
It reduces heat loss by conduction and convection. [1]
- (ii) As dark-coloured surface is a good absorber of thermal radiation, thermal energy is absorbed by the copper pipes at a faster rate. [1]
- As copper is a good conductor of heat, thermal energy is transferred from the copper to the fluid more effectively. [1]
- (b) As the copper molecules gain thermal energy from the sun, it gains kinetic energy and vibrates faster about its fixed position. These molecules collide with their less energetic neighbouring molecules and some of their energy is transferred to them. [1]
- Copper also contains free electrons. When heated, free electrons gain energy and move faster. These free electrons are free to travel in the spaces between the molecules before colliding with other electrons and molecules and transferring some of their energy to them. [1]
- These processes continue until the transfer of energy reaches the opposite end of the copper and the energy is transferred to the fluid in the pipe. [1]
- (c) As hot water is less dense than cold water, hot water rise and cold water sink. The position of the inlet and outlet is to ensure even distribution of the hot water in the water tank. [1]  
[1]
- (d)(i) If the freezing point is too high, the fluid might freeze if the temperature of the surrounding drops and the system will not be able to function. [1]
- 3 (a)(i) Left: upwards [1]  
Right: downwards [1]
- (ii) A current flows in the circuit and the coil. Since there is current in a magnetic field, a force is produced. [1]  
The force on the left side of the coil is upwards and on the right side the force is equal and opposite causing the coil to turn . [1]
- (iii) Use stronger magnets.  
Increase the current.  
Place a soft iron between the magnets. (Any two) [2]
- (b) (i) When switch is closed, the soft iron becomes an electromagnet OR is magnetised and the paper clips are attracted to it. [1]  
When switch is open, the paper clips drop because iron does not retain magnetism. [1]
- (ii) When the switch is closed, the paper clips are attracted to the steel rod because the steel rod is magnetised. No. of paper clips is reduced. [1]  
When the switch is opened, some of the paper clips remains attracted to the steel rod because the steel rod remains magnetised. [1]

NAME	CLASS	INDEX NO.
------	-------	-----------



**ST. PATRICK'S SCHOOL  
PRELIMINARY EXAMINATIONS 2016**

**SUBJECT : SCIENCE (PHYSICS)      DATE : 31 AUGUST 2016**  
**5116 PAPER 5**

**LEVEL : SECONDARY 4E / 5N      DURATION : 1 HOUR 30 MIN**

**INSTRUCTIONS TO CANDIDATES**

**DO NOT OPEN THIS BOOKLET UNTIL YOU ARE TOLD TO DO SO.**

1. Write your name, class and index number on this **examination booklet** as well as the **annex**.
2. Write in dark blue or black pen in the spaces provided in the booklet. You may use a soft pencil for any diagrams, graphs or rough working. Do not use staples, paper clips, highlighters, glue or correction fluid.
3. All your answers should be written in this booklet.
4. At the end of the examination, fasten the sheets of A4 paper and the graph paper to the question paper booklet.

**For Marker's Use Only**

For Examiner's Use	
Total	15

This examination booklet has 4 printed pages including the cover page

**Before beginning the exercise you are advised to read the given instructions carefully and completely, so that you know exactly what has to be done.**

In this experiment, you will investigate the path of a ray of light through a rectangular glass block.

- (a) Draw a horizontal line, PQ, across one of the sheets of blank A4 paper such that PQ is 14 cm from the top end of the paper. Place the glass block, such that its length touches PQ and draw its outline. Remove the glass block.
- (b) Draw a normal to the block at a distance 1.0 cm from one corner, as shown in Figure 1.1.

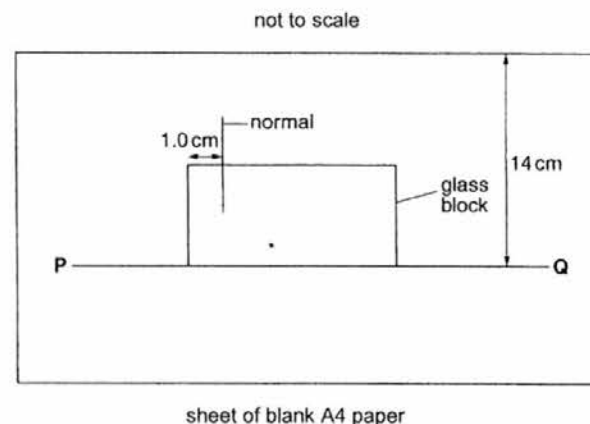

Figure 1.1

- (c) Draw a straight line ABC at an angle  $i = 20^\circ$  to the normal. Label the point C, as shown in Figure 1.2.

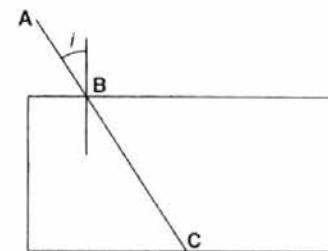

Figure 1.2

- (d) Place the sheet of paper on the pin board. Replace the glass block in the same position on the paper. Insert two pins  $P_1$  and  $P_2$  into the paper along line AB.
- (e) Look at pins  $P_1$  and  $P_2$  through the glass block. Insert two further pins  $P_3$  and  $P_4$  into the paper so that all four pins appear to be in a straight line.
- (f) Remove the glass block and the four pins from the paper. Draw a straight line DE through the holes made by pins  $P_3$  and  $P_4$ , as shown in Figure 1.3.

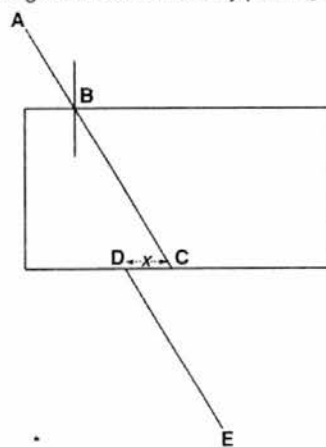

Figure 1.3

- (g) Measure and record the distance  $x$  between points C and D.  
 $x = \dots\dots\dots$  cm
- (h) Repeat steps (c) to (g) for angles of incidence  $i$  of  $30^\circ$ ,  $40^\circ$ ,  $50^\circ$  and  $55^\circ$ . Record all of your results in Figure 1.4. [5]

$i / ^\circ$	$x / \text{cm}$
0	0.0
20	
30	
40	
50	
55	

Figure 1.4

- (i) Plot a graph of  $x$ , on the vertical axis, against angle of incidence  $i$  using the graph paper provided. [4]

- (j) (1) Do your results support the idea that  $x$  is proportional to  $i$ ? Explain your answer.  
.....  
.....  
..... [2]

- (2) Suggest two ways in which this experiment can be improved so that the answer to (1) is more certain.  
.....  
.....  
..... [2]

- (k) (1) Use your graph to predict a value for  $x$  when  $i = 10^\circ$ .  
 $x = \dots\dots\dots$  cm
- (2) Suggest why you were not asked to measure this value.  
.....  
..... [2]

End of Paper

MARKING SCHEME (4E / 5NA SCI PHY) PRELIM EXAM PAPER 5 (2016)

PHYSICS QUESTION (15 MARKS)

(h) Result Table

$i / ^\circ$	$x / \text{cm}$
0	0.0
20	0.8
30	1.6
40	2.7
50	4.3
55	5.2

Readings for  $x$  all to 1 decimal place [1]

Readings for  $x$  without unit [1]

Drawings of 5 A4 sheets all must draw line ABC [1]

Must label point C in all diagrams [1]

Must draw line DE in all diagrams [1]

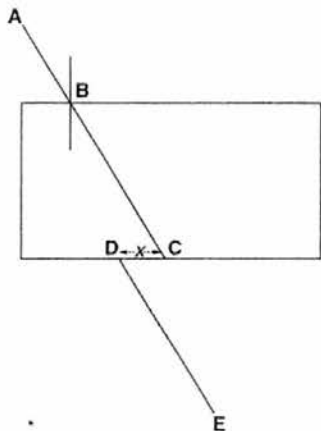

(i)

Label vertical axis as  $x / \text{cm}$  and with appropriate scale [1]

Label horizontal axis as  $i / ^\circ$  and with appropriate scale [1]

Plot all points correctly using cross 'x' [1]

Draw best-fit curve [1]

(j) (i) No,  $i$  is not proportional to  $x$  [1]

because the graph obtained is a curve. [1]

(ii)

1. Ensure 4 pins ( $P_1$ ,  $P_2$ ,  $P_3$  and  $P_4$ ) inserted into the pin board are upright and not tilted. [1]

2. Ensure 2 pins ( $P_1$  &  $P_2$  and  $P_3$  &  $P_4$ ) are placed at a reasonable distance apart. [1]

(k) (i) When  $i = 10^\circ$ ,  $x = \underline{0.3}$  cm [mark awarded based on student's answer] [1]

(ii) The angle is too small and it may reduce the accuracy in obtaining the emergent ray. [1]