

Visit

FreeTestPaper.com

for more papers

Answer all the questions.

- 1 (a) Simplify $9 - 5(2x + 3)$.

Answer: [1]

- (b) Factorise $30xy^2 - 6xy$.

Answer: [1]

- 2 (a) These are the first five terms in a sequence.

1 4 9 16 25

Write down an expression for the n th term of this sequence.

Answer: [1]

- (b) Hence, write down an expression for the n th term of this sequence.

4 7 12 19 28

Answer: [1]

- 3 Determine if 3^{400} or 8^{200} is greater. Explain your answer.

Answer:

[2]

- 4 (a) On the diagram, sketch the graph of $y = -\frac{1}{x}$. The point $(1, -1)$ is marked.

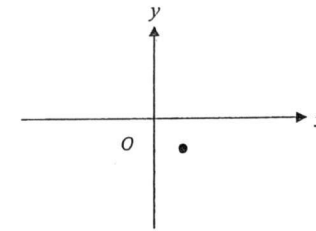

[1]

- (b) On the diagram, sketch the graph of $y = \frac{1}{x^2}$. The point $(1, 1)$ is marked.

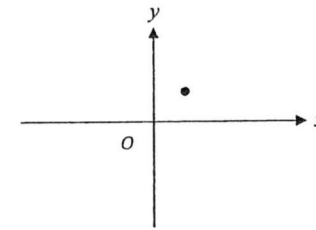

[1]

- 5 (a) Express $7 - 4x + x^2$ in the form $p + (x + q)^2$ where p and q are constants.

Answer: [2]

- (b) Hence, explain why $7 - 4x + x^2 = 0$ has no real solution.

Answer: [1]

- 6 The table shows the number of goals scored in the soccer matches played by a group of boys in S League.

Number of Goals	1	2	3	4
Number of Matches	4	2	7	x

- (a) The boys scored 4 goals in x number of matches. Given that the modal number of goals is 3, find the greatest possible number of matches played by the boys during the league.

Answer: [1]

- (b) Part of the above table is represented in the pictogram.

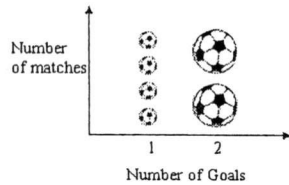

State one aspect of the graph that may be misleading and explain how this may lead to a misinterpretation of the pictogram.

Answer:

 [2]

- 7 Megan is playing with 594 cubes. Megan uses all 594 cubes to make a cuboid. Each of the sides of the cuboid is made up of more than 3 cubes. Find the number of cubes on each side of the cuboid.

Answer: × × [3]

- 8 When an object travels in a circular motion, there are two equations which govern the physics of the motion.

$$\text{Equation I: } F = \frac{Mv^2}{r}$$

$$\text{Equation II: } F = \frac{GMN}{r^2}$$

- (a) Given that $M = 7 \times 10^{22}$, $v = 1.2 \times 10^3$ and $r = 2.6 \times 10^7$, using equation I, evaluate F . Leave your answers in standard notation.

Answer: $F =$ [1]

- (b) Using both equations I and II, express v in terms of N , G and r .

Answer: [2]

- 9 (a) Solve the inequality $17 - 4x < x + 5 \leq 3x - 6$.

Answer: [2]

- (b) Hence, write down the smallest value of x if x is a prime number.

Answer: [1]

- 10 The freezing point of a liquid is -7°C . The temperature difference between its freezing point and boiling point is 25°C .

(a) Find the boiling point of the liquid.

Answer: $^{\circ}\text{C}$ [1]

(b) An addition of a small quantity of salt into the liquid decreased its freezing point by $x^{\circ}\text{C}$ and increased its boiling point by $y^{\circ}\text{C}$.

Find the temperature difference between the freezing point and the boiling point of this liquid-salt mixture, in terms of x and y .

Answer: $^{\circ}\text{C}$ [2]

- 11 In the diagram below, $AB = 6\text{ cm}$, $BC = 4\text{ cm}$, $AE = 5\text{ cm}$ and $\angle AEB = \angle ACD$.

Find the length of DE .

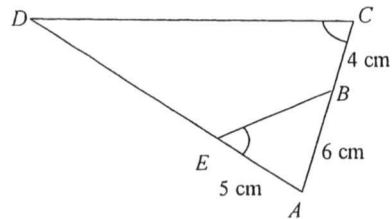

Answer: cm [3]

- 12 In the diagram below, not drawn to scale, $ABCD$ is a square. A is $(0, 7)$, B is $(3, 0)$ and C is $(10, 3)$.

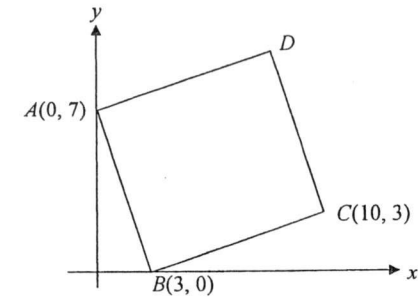

(a) Find the coordinates of D .

Answer: $D(\text{.....}, \text{.....})$ [1]

(b) Find the area of triangle BCS , where S is the centre of the square.

Answer: units^2 [2]

- 13 $\varepsilon = \{x : 6 < x < 20\}$
 $A = \{x : x \text{ is an even number}\}$
 $B = \{x : x \text{ is a multiple of } 3\}$

(a) List the elements of

(i) A' ,

Answer: [1]

(ii) $A' \cap B$.

Answer: [1]

(b) On the Venn diagram shown, shade the set $A' \cup B'$.

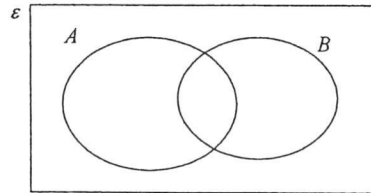

[1]

- 14 Class A and class B have 40 students each. The box-and-whisker plot below shows the distribution of their marks in a Math test.

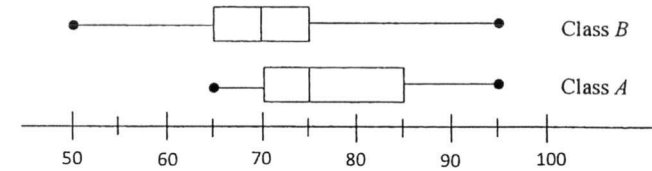

(a) Find the number of students in class A , who scored less than 85 marks.

Answer: [1]

(b) Below are two statements comparing the marks for Class A and B . For each one, write whether you agree or disagree, giving a reason for each answer.

Statement	Agree/ Disagree	Reason
Students in Class A score better		
Greater number of students in Class A score at least 70 marks		

[2]

- 15 There are three jugs X , Y and Z . Jugs X and Y are geometrically similar. The volume of X and Y are 216 cm^3 and 512 cm^3 respectively.

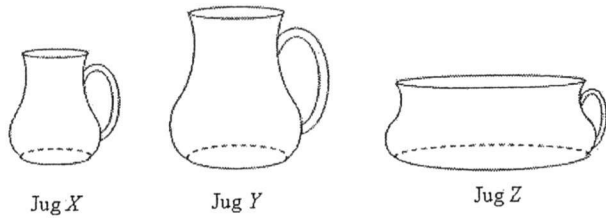

- (a) Find the ratio of the height of X to Y .

Answer: [1]

- (b) The volume of X is given by the formula $V = \frac{7}{15}r^2h$ where h is the height of the jug and r the radius of the circular base. Find the volume of Z which has $\frac{3}{4}$ the height of X and thrice the radius of the circular base of X .

Answer: cm^3 [2]

- 16 In the diagram, the coordinates of $P(8, 15)$ and $Q(-3, 4)$ are drawn.

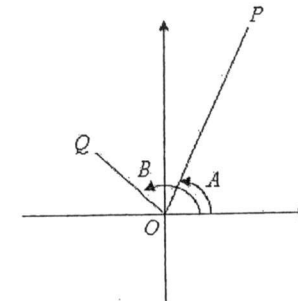

- (a) Find the value of $\tan A$.

Answer: [1]

- (b) Find the value of $\cos B$.

Answer: [2]

- 17 (a) The figure below shows a quadrilateral. Identical circles with radius of 2 cm are drawn such that the centres of the circles are at the vertices of the quadrilateral. Calculate the area of the shaded region if each of the side of the quadrilateral is at least 5 cm. Leave your answer in π .

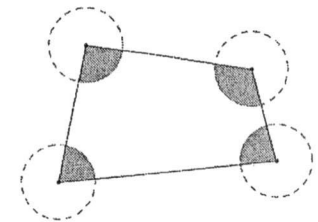

Answer: cm^2 [2]

- (b) In the diagram, $ABCD$ is a rhombus.
 AX is perpendicular to BC and intersects BD at L .

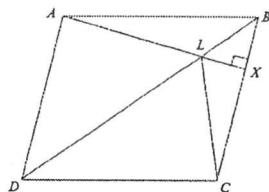

Prove that $\triangle ALD$ is congruent to $\triangle CLD$.

Answer:

[2]

- 18 An area of 324 km^2 is represented on a map by an area of 36 cm^2 .

- (a) Find the scale of the map in the form $1 : n$.

Answer: [2]

- (b) Find the length of a road on the map with an actual distance of 85 km , leaving your answer to the nearest centimeters.

Answer: cm [2]

- 19 The sketch shows the graph of $y = ka^x + 1$. The graph passes through the points $P(0, -2)$ and $Q(5, -95)$.

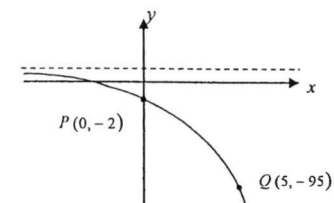

- (a) Find the values of k and a .

Answer: $k =$

..... [2]
 $a =$

- (b) A straight line is drawn from P to Q .
 Find the equation of the line PQ .

Answer: [2]

- 20 Alvin rented a 696 square feet apartment in Washington D.C. for 1800 USD.
Benjamin rented a 60 m² apartment in Beijing for 6500 CNY.

1.00 USD = 6.81 CNY.
1 square feet = 0.093 m².

Which apartment is cheaper to rent? You must show your calculations.

Answer: [4]

- 21 (a) Factorise completely $5ax - 5ay - 25dx + 25dy$.

Answer: [2]

- (b) Write as a single fraction in its simplest form $\frac{5}{x-2} + \frac{11}{x^2-4}$.

Answer: [2]

- 22 The diagram shows the speed-time graph of a car's journey.

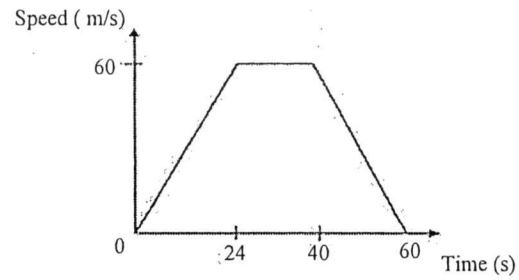

- (a) Calculate the acceleration when $t = 15$ s.

Answer: m/s^2 [1]

- (b) Calculate the time taken by the car to travel 1.62 km.

Answer: s [3]

- 23 The diagram shows four points A , B , C and D on the circumference of a circle centre O .

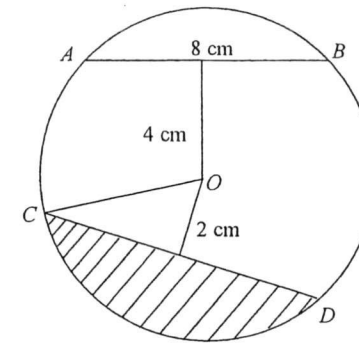

AB is a chord of length 8 cm and is 4 cm from O . CD is a chord 2 cm from O . Find the area of the shaded segment.

Answer: cm^2 [4]

- 24 The diagram shows a circle BDC , with centre O . $\angle BOD = 110^\circ$, AE and DE are tangents to the circle at B and D respectively.

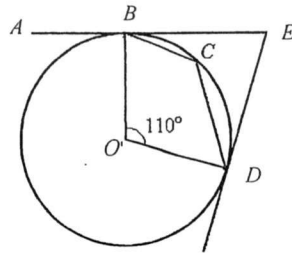

- (a) Showing all reasons clearly, find $\angle BCD$.

Answer: $^\circ$ [2]

- (b) Explain why $OBED$ lie on the circumference of another circle.

Answer:

[2]

- 25 Points A , B and C are three checkpoints on flat ground. Points A and B are given below.

- (a) Point C is located 7 km away from Point A , at a bearing of 160° . Using a scale of 1 cm to represent 1 km, construct and label the position of checkpoint C clearly. [1]
- (b) A checkpoint D is to be built equidistant from
 I. A and B .
 II. AB and AC .
 Using ruler and compasses only, find and label the position of the checkpoint D . [3]

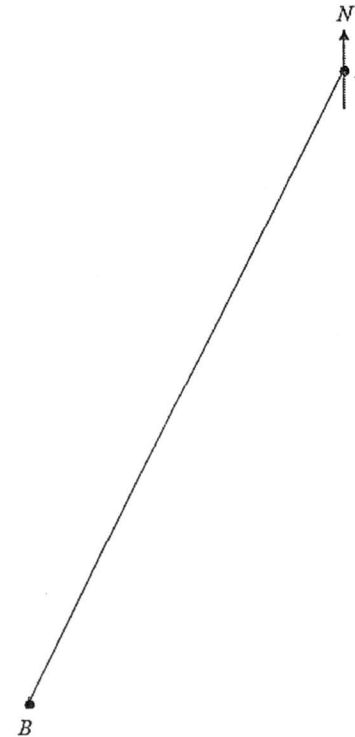

End of Paper

Secondary 4 Express/ 5NA Mid Year Examination 2017
Mathematics 4048 Paper 1 Marking Scheme

1	(a)	$-10x - 6$	B1	1
	(b)	$6xy(5y - 1)$	B1	1
Marker's comment:				

2	(a)	n^2	B1	1
	(b)	$n^2 + 3$	B1	1
Marker's comment:				

3		$3^{400} = 3^{2(200)}$ $= 9^{200}$ $9^{200} > 8^{200}$ Hence 3^{400} is greater.	M1	M1 for showing 9^{200} No A1 if no explanation.
			A1	2
Marker's comment:				

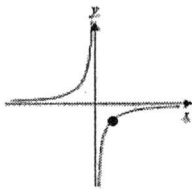
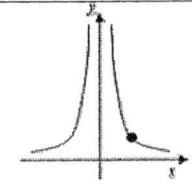
4	(a)		B1	1
	(b)		B1	1
Marker's comment:				

5	(a)	$(x - 2)^2 + 7 - 4$ $= 3 + (x - 2)^2$	M1	A1	2
	(b)	$(x - 2)^2$ is always positive or zero hence $3 + (x - 2)^2$ is always greater than zero or does not cut the x axis, hence no solution.	B1	1	
Marker's comment:					

6	(a)	19	B1	1
	(b)	The size of the football is not the same hence it may mislead that bigger football means more matches. Or Pictogram of same height may mislead that both have same number of matches.	B1	B1 for different size B1 for bigger football is misleading as it means more matches. B1 B1 for same height B1 2 B1 for it misleads that both have same number of matches.
Marker's comment:				

7		$594 = 2 \times 3^3 \times 11$ $= (2 \times 3) \times 3^2 \times 11$ (each side made up of more than 3) $= 6 \times 9 \times 11$	M1	M1	A1	3
Marker's comment:						

8	(a)	$F = 3.88 \times 10^{21}$	B1	1	Rounded off to 3sf.	
	(b)	$\frac{GMN}{r^2} = \frac{Mv^2}{r}$ $v^2 = \frac{GN}{r}$ $v = \pm \sqrt{\frac{GN}{r}}$	M1	A1	2	
Marker's comment:						

9	(a)	$x + 5 \leq 3x - 6$ $-2x \leq -11$ $x \geq 5.5$ $17 - 4x < x + 5$ $-5x < -12$ $x > 2.4$ Hence $x \geq 5.5$.	M1	A1	2	
	(b)	7	B1	1		
Marker's comment:						

10	(a) 18°C	B1	1
	(b) $18 + y - (-7 - x)$ $= 25 + y + x$	M1√ A1	ecf for their (a) 2

Marker's comment:

11	$\frac{AD}{6} = \frac{10}{5}$ $AD = 12$ $DE = 12 - 5$ $= 7 \text{ cm}$	M1 M1 A1	3
----	---------------------------------------------------------------------------------	----------------	---

Marker's comment:

12	(a) $D(7, 10)$	B1	1
	(b) length $AB = \sqrt{7^2 + 3^2}$ $= \sqrt{58}$ Area of $\triangle BCS = \frac{(\sqrt{58})^2}{4}$ $= 14.5 \text{ units}^2$	M1 A1	M1 for length of $BC = AB$ 2

Marker's comment:

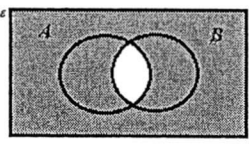
13	(ai) {7, 9, 11, 13, 15, 17, 19}	B1	1
	(a ii) {9, 15}	B1	1
	(b) 	B1	1

Marker's comment:

14	(a) $\frac{75}{100} \times 40 = 30 \text{ students}$	B1	1
	(b) Agree because the students in class A has higher median score.	B1	1 B1 for agree and correct reason.
	Agree because Q_2 , 50 th percentile of students in class B score 70 marks or less while Q_1 , 25 th percentile of students in class A score 70 marks or less	B1	1 B1 for agree and correct reason.

Marker's comment:

15	(a) $\frac{\text{height of } X}{\text{height of } Y} = \frac{\sqrt{216}}{\sqrt[3]{512}}$ $= \frac{3}{4}$ Ratio 3 : 4	B1	1
	(b) $V = \frac{7}{15}(3r)^2 \frac{3}{4}h$ $= \frac{27}{4} \times \frac{7}{15} r^2 h$ $= \frac{27}{4} \times 216$ $= 1458 \text{ cm}^3$	M1 A1	M1 for substituting into formula 2

Marker's comment:

16	(a) $\frac{15}{8}$	B1	1
	(b) $OQ = \sqrt{3^2 + 4^2}$ $= 5$ $\cos B = -\frac{3}{5}$	M1 A1	2

Marker's comment:

17	(a) Sum of int angle = 360° 360° is the same as angle at a point. Hence area of shaded region = $\pi (2)^2$ $= 4\pi \text{ cm}^2$	B2	2
	(b) $AD = CD$ (sides of a rhombus) $\angle ADL = \angle LDC$ (LD bisects $\angle ADC$) DL is common. By SAS, $\triangle ALD$ is congruent to $\triangle CLD$.	M1 A1	2

Marker's comment:

18	(a) 36 cm ² on map rep 324 km ² on ground 6 cm on map rep 18 km on ground 1 cm on map rep 3 km on ground $\therefore 1 : 300\ 000$	M1 A1	M1 accept 1 cm ² on map rep 9 km ² on ground 2
	(b) $\frac{85}{3} = 28.333$ $\approx 28 \text{ cm}$ (nearest cm)	M1√ A1	ecf for their (a) 2

Marker's comment:

19	(a)	Sub. (0, -2), $-2 = ka^0 + 1$ $k = -3$	B1	
		Sub. (5, -95) and $k = -3$, $-95 = -3a^5 + 1$ $-96 = -3a^5$ $32 = a^5$ $a^5 = 2^5$ $a = 2$	B1	2
	(b)	$m = \frac{-95 - (-2)}{5}$ $= -\frac{93}{5}$ $y = -\frac{93}{5}x - 2$	M1	Accept m as -18.6
			A1	2

Marker's comment:

20		$1800\text{USD} = 1800 \times 6.81\text{CNY}$ $= 12\,258\text{CNY}$	M1	Accept alternative comparison with common basis. Eg in USD.
		$696\text{ sq ft} = 696 \times 0.093\text{m}^2$ $= 64.728\text{ m}^2$	M1	
		Alvin's apartment cost 189.38 CNY/m^2 Benjamin's apartment cost 108.33 CNY/m^2	M1	Accept alternative comparison with common basis. Eg. in Sq feet.
		So it is cheaper to rent Benjamin's apartment	A1	4

Marker's comment:

21	(a)	$5a(x-y) - 25d(x-y)$ $5(a-5d)(x-y)$	M1	
			A1	2
	(b)	$\frac{5(x+2)}{(x-2)(x+2)} + \frac{11}{(x-2)(x+2)}$ $\frac{5x+10+11}{(x-2)(x+2)}$ $\frac{5x+21}{(x-2)(x+2)}$	M1	
			A1	2

Marker's comment:

22	(a)	$\frac{60}{24} = 2.5\text{ m/s}^2$	B1	1
	(b)	Let t be the time taken to travel 1.62 km. $1620 - \frac{1}{2}(24)(60) = 900\text{ km}$ $60(t-24) = 900$ $t-24 = 15$ $t = 39\text{ s}$	M1	
			M1	
			A1	3

Marker's comment:

23		Radius $= \sqrt{4^2 + 4^2}$ $= \sqrt{32}$ $= 5.66\text{ cm}$ (3 sig. fig.)	M1	
		$\angle COD = 2 \times \cos^{-1}\left(\frac{2}{\sqrt{32}}\right)$ $= 138.590^\circ$	M1	
		Area of shaded region $= \left[\frac{138.590}{360} \times \pi \times (\sqrt{32})^2 \right] -$ $\left(\frac{1}{2} \times \sqrt{32} \times \sqrt{32} \times \sin 138.590 \right)$	M1	
		$= 28.118$ $= 28.1\text{ cm}^2$ (3 sig. fig.)	A1	

Marker's comment:

24	(a)	$\text{reflex}\angle BOD = 360 - 110$ $= 250^\circ$ (angle at a point)		
		$\angle BCD = \frac{250}{2}$ $= 125^\circ$ (\angle at centre = $2\angle$ at circumf)	M1	
			A1	
	(b)	$\angle BED = 360 - 110 - 90 - 90$ $= 70^\circ$ (sum of int \angle of quad) Since $\angle BED + \angle BOD = 180^\circ$ (properties of cyclic quad or \angle in the opp segment), $OBED$ lie on the circumference of a circle.	M1	
			A1	

Marker's comment:

25 (a)		<p>B1 1 B1 for labelling of checkpoint C correctly.</p>
(b)	<p>Angle bisector $\angle BNC$ Perpendicular bisector of AB Point D labelled</p>	<p>B1√ ecf for their (a) B1 B1 3</p>
<p>Marker's comment:</p>		

Answer all the questions.

- 1 (a) Simplify $\left(\frac{2}{xy^2}\right)^{-3} + \left(\frac{2x}{3y}\right)$. [2]
- (b) Simplify $\frac{x^2 + 4x - 21}{2x^2 - 18}$. [2]
- (c) Solve the equation $(p-2)(2p-7) = 9$. [3]

- 2 John has three 50 cent coins and two 10 cent coins in his pocket. He takes two coins out of his pocket, at random, one after another. The coins are not replaced.
- (a) Draw a complete probability tree diagram to show the possible outcomes and their probabilities. [2]
- (b) Find the probability that the total value of the two coins taken out is
- (i) 20 cents, [1]
- (ii) 60 cents. [2]
- (c) John takes out a third coin from his pocket. Find the probability that the total value of the three coins taken out is 70 cents. [2]

- 3 (a) (i) Express 2025 as a product of its prime factors. [1]
- (ii) Using your answer to part a(i), explain why 2025 is a perfect square. [1]
- (iii) m and n are both prime numbers.
Find the values of m and n so that $2025 \times \frac{m}{n}$ is a perfect cube. [1]

- (b) A gift shop sells three types of goodie bags.

Bag A contains 3 bottles of soft drink and 5 boxes of chocolates.

Bag B contains 2 bottles of soft drink, 3 boxes of chocolates and 5 boxes of candies.

Bag C contains 1 bottle of soft drink, 2 boxes of chocolates and 7 boxes of candies.

The cost price of a bottle of soft drink is \$2, a box of chocolates is \$12 and a box of candies is \$5.

The numbers of each type of item in each goodie bag are represented by the matrix

$$\mathbf{Q} = \begin{pmatrix} 3 & 5 & 0 \\ 2 & 3 & 5 \\ 1 & 2 & 7 \end{pmatrix}$$

- (i) Represent the cost price for each type of item in the goodie bag by the matrix \mathbf{P} . [1]
- (ii) Evaluate $\mathbf{M} = \mathbf{QP}$. [1]
- (iii) State what the elements of \mathbf{M} represent. [1]
- (iv) The shop intends to make a profit of 15% on goodie bag A , 20% on goodie bag B and 30% on goodie bag C .

Write down a matrix \mathbf{N} such that the product \mathbf{NM} gives the selling price of each goodie bag. [1]

- (v) Evaluate \mathbf{NM} . [1]

- 4 (a) The cost, c dollars, of the electricity bill is given by the formula $c = p + qn$, where n is the number of units of power used.
Mrs Tan has to pay \$54 if she uses 300 units of power and \$78 if she uses 500 units of power.
- (i) Write down a pair of simultaneous equations in terms of p and q to represent this information. [2]
- (ii) Solve these simultaneous equations to find the values of p and q . [2]
- (iii) Find the number of units of power used by Mrs Tan if she has to pay \$68.40. [1]
- (b) A shopkeeper raises the prices of his goods by 10%. He then starts the annual sales by offering his customers a discount of 10%.
- Did the customers actually receive any discount? Explain your answer showing clear working. [2]
- (c) If the height of a triangle is decreased by 20% while its area remained unchanged, find the percentage change in the length of the base. [2]

- 5 The amount of money collected by 80 members of the school soccer club for a fundraising event is distributed as shown in the cumulative frequency curve below.

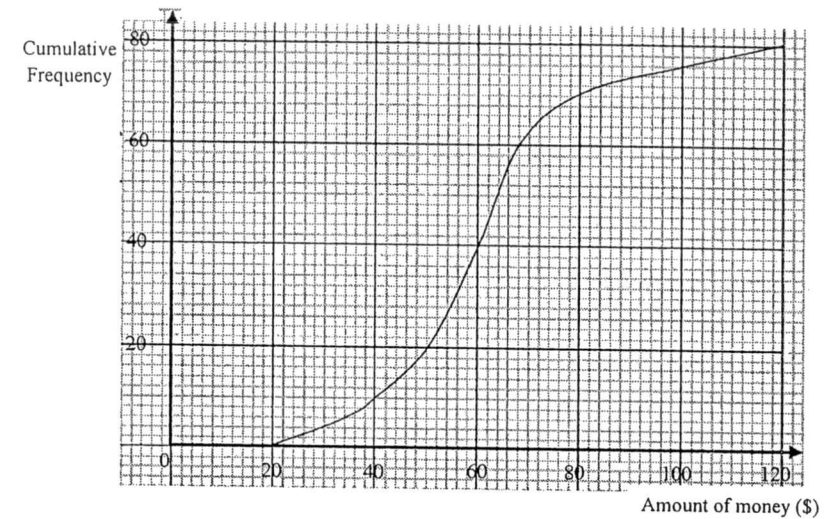

- (a) Use the cumulative frequency curve to estimate
- (i) the median amount of money raised, [1]
- (ii) the interquartile range. [2]
- (b) The same information can be represented using a grouped frequency table as shown below.

Amount of money (\$)	$20 < x \leq 40$	$40 < x \leq 60$	$60 < x \leq 80$	$80 < x \leq 100$	$100 < x \leq 120$
Frequency	p	30	30	q	4

- (i) Obtain the values of p and q . [2]
- (ii) Using your grouped frequency table, calculate an estimate of the mean and standard deviation. [3]
- (c) 80 members from the school outdoor club also raised funds for the same event. The box-and-whisker plot shows the distribution of the amount collected by them.

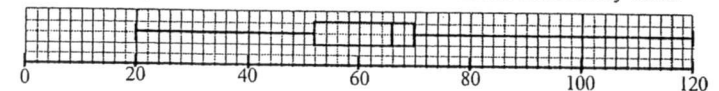

Using the data from the box-and-whisker plot, make 2 comments about the amount of money collected by the two different clubs. [3]

- 6 In the diagram, O is the centre of the largest semicircle. The circle with centre R has a radius of $(3r + 2)$ cm. Two identical semicircle, with centres P and Q , each has a radius of $(6r + 1)$ cm.

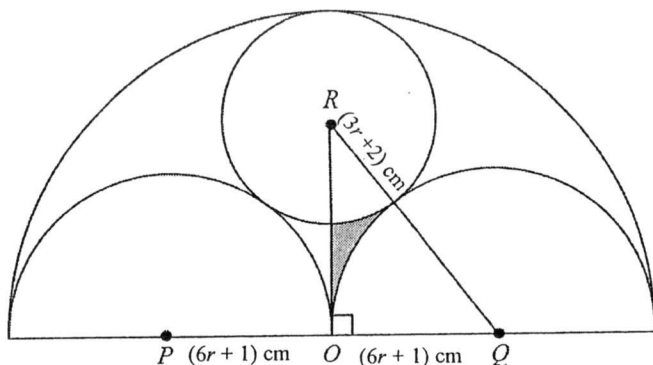

- (a) Write down an expression, in terms of r , for
- (i) QR , [1]
- (ii) OR . [2]
- (b) Form an equation in r and show that it reduces to $18r^2 - 21r - 4 = 0$. [2]
- (c) Solve the equation $18r^2 - 21r - 4 = 0$. [3]
- (d) Find the area of the shaded region. [4]

- 7 (a) P is the point $(7, 1)$ and Q is the point $(2, 6)$.
- (i) Find $\left| \overrightarrow{PQ} \right|$. [2]
- (ii) If $\overline{SP} = 3\overline{PQ}$, find the coordinates of S . [2]
- (iii) Given that $\overline{OR} = \begin{pmatrix} h+2 \\ 5 \end{pmatrix}$, find the value of h if \overline{OR} is parallel to \overline{PQ} . [1]

(b)

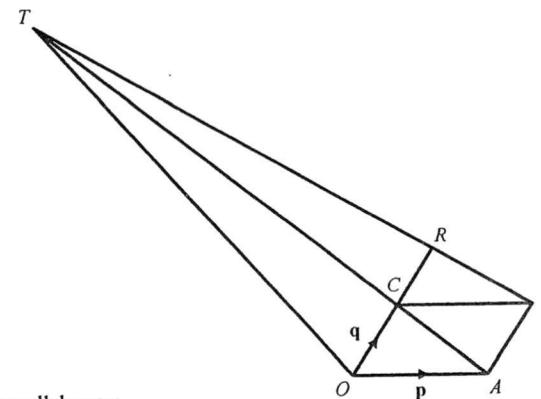

$OABC$ is a parallelogram.
 $\overline{OA} = \mathbf{p}$, $\overline{OC} = \mathbf{q}$ and $\overline{CT} = 4\overline{AC}$.
 ACT , BRT and OCR are straight lines.

- (i) Express each of the following, as simply as possible, in terms of \mathbf{p} and/or \mathbf{q} .
- (a) \overline{OB} , [1]
- (b) \overline{OT} , [2]
- (c) \overline{BT} . [1]
- (ii) Given that $\overline{BR} = \frac{4}{5}\mathbf{q} - \mathbf{p}$, find k if $\overline{OC} = k\overline{CR}$. [2]
- (iii) Find the value of $\frac{\text{area of } \Delta BCR}{\text{area of } \Delta CRT}$. [1]

8 Answer the whole of this question on a sheet of graph paper.

The variables x and y are connected by the equation $y = \frac{1}{2}x^3 - 3x^2 + 7$.

Some corresponding values of x and y are given in the table below.

x	-2	-1	0	1	2	3	4	5	6
y	-9	p	7	4.5	-1	-6.5	-9	-5.5	7

- (a) Find the value of p . [1]
- (b) Using a scale of 2 cm to represent 1 unit, draw a horizontal x -axis for $-2 \leq x \leq 6$. Using a scale of 1 cm to represent 1 unit, draw a vertical y -axis for $-9 \leq y \leq 7$. On your axes, plot the points given in the table and join them with a smooth curve. [3]
- (c) The equation $\frac{1}{2}x^3 - 3x^2 = -12$ has three solutions. Explain how this can be seen from your graph. [2]
- (d) By drawing a tangent, find the gradient of the curve at $x = 0.5$. [2]
- (e) (i) On the same axes, draw the graph of $y = 2 - x$ for $-2 \leq x \leq 6$. [1]
- (ii) Write down the x -coordinate of the points where this line intersects the curve. [1]
- (iii) The x -coordinates of the points where the two graphs intersect are solutions of the equation $x^3 + ax^2 + bx + c = 0$. Find the values of a , b and c . [2]

9. In the diagram below, Q , R and S are three points on horizontal ground. $RQ = 8.9$ m and $SR = 12.5$ m. A vertical flag pole PQ stands at Q and the angle of depression of R from P is 27° . R is due south of Q and the bearing of S from R is 053° .

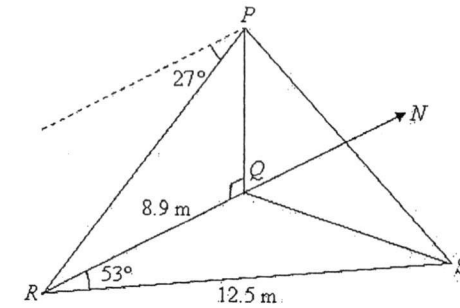

- (a) Find
- (i) the length of QS , [3]
- (ii) the angle QSR , [2]
- (iii) the bearing of S from Q , [1]
- (iv) the area of triangle QRS , [2]
- (v) the height of flag pole PQ . [2]
- (b) A man walks from R to S . Find the greatest angle of elevation of P from a point on RS . [2]

10. Large canals are used in Singapore to regulate water flow to prevent floods from occurring.



In this question, the canal can be modelled as a trapezoid attached to the top of a half-cylinder as shown below.

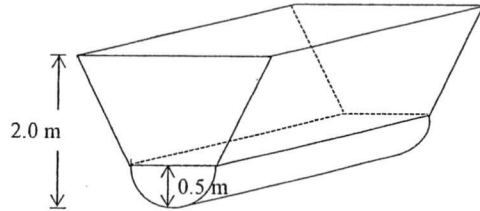

The cross section of the drain is made up of a trapezium and a semicircle. The radius of the semicircle is 0.5 m and the vertical height measured from the bottom of the semicircle to the top of the trapezium is 2 m. The length of one of the parallel sides of the trapezium is twice the length of the other.

- (a) Find the lengths of the parallel sides and the vertical height of the trapezium. [2]
- (b) Calculate the volume of the drain, in cubic metres, which stretches for 10 m. [4]
- (c) A drain must be able to channel away 90% of the rain water within 30 seconds. If not, preventive measures need to be set up to curb the flood.

Useful Information

- The rate of flow of water for this drain during a particular rainstorm is 48000 litres per minute
- 1 m^3 is equivalent to 1000 litres

Determine whether preventive measures need to be set up for that particular rainstorm. Show your working and give reasons to justify your answer. [4]

End of Paper 2

Secondary 4 Express/ 5NA Mid Year Examination 2017
Mathematics 4048 Paper 2 Marking Scheme

Deduct 1 mark overall for missing or incorrect units.

1	(a)	$\left(\frac{xy^2}{2}\right)^3 \times \frac{3y}{2x}$ $= \frac{3x^2y^7}{16}$	B1 B1	2	
	(b)	$\frac{(x+7)(x-3)}{2(x+3)(x-3)}$ $= \frac{x+7}{2(x+3)}$	M1 A1	2	M1 for both expression factorised
	(c)	$2p^2 - 7p - 4p + 14 = 9$ $2p^2 - 11p + 5 = 0$ $(2p-1)(p-5) = 0$ $p = \frac{1}{2}$ or 5	M1 M1 A1	2	Correct expansion Either using factorisation or quadratic formula
Marker's comment:					

2	(a)	Complete correct tree diagram for 2 selections with all 6 probabilities correct.			
			B2	2	Award B1 for branches if first selection correct. Probability: $\frac{2}{4}$ o.e.
	(bi)	$P(20 \text{ cents}) = \frac{2}{5} \times \frac{1}{4} = \frac{1}{10}$	B1	1	
	(bii)	$P(60 \text{ cents}) = \frac{3}{5} \times \frac{2}{4} + \frac{2}{5} \times \frac{3}{4}$ $= \frac{3}{5}$	M1 A1	2	✓ their tree diagram

(c)	$P(70 \text{ cents})$ $= \left(\frac{3}{5} \times \frac{2}{4} \times \frac{1}{3}\right) + \left(\frac{2}{5} \times \frac{3}{4} \times \frac{1}{3}\right) + \left(\frac{2}{5} \times \frac{1}{4} \times \frac{3}{3}\right)$ $= \frac{3}{10}$	M1 A1	2	✓ their tree diagram
Marker's comment:				

3	(ai)	$3^4 \times 5^2$	B1	1	
	(aii)	Indices of the prime factors are all multiples of 2/ divisible by 2.	B1	1	
	(aiv)	$m = 5, n = 3$	B1	1	B1 for both correct values
	(bi)	$P = \begin{pmatrix} 2 \\ 12 \\ 5 \end{pmatrix}$	B1	1	
	(bii)	$M = \begin{pmatrix} 3 & 5 & 0 \\ 2 & 3 & 5 \\ 1 & 2 & 7 \end{pmatrix} \begin{pmatrix} 2 \\ 12 \\ 5 \end{pmatrix}$ $= \begin{pmatrix} 66 \\ 65 \\ 61 \end{pmatrix}$	B1	1	✓ for their (bi)
	(biii)	The elements represent the cost price of each type of goodie bag respectively.	B1	1	
	(biv)	$\begin{pmatrix} 1.15 & 0 & 0 \\ 0 & 1.2 & 0 \\ 0 & 0 & 1.3 \end{pmatrix}$	B1	1	
	(bv)	$\begin{pmatrix} 75.90 \\ 78 \\ 79.30 \end{pmatrix}$	B1	1	✓ for their (biv) Do not award if elements are not to 2 d.p. for non-exact answers
Marker's comment:					

4	(ai)	$p + 300q = 54 \quad -(1)$ $p + 500q = 78 \quad -(2)$	B1 B1	2	
	(aii)	$p = 18$ and $q = 0.12$.	B2	2	or M1 for correct method to substitute or eliminate one variable.
	(aiii)	420	B1	1	B1 for 1 correct solution. ✓ their p and q
	(b)	Let the original price of the goods be \$ x . Price after the discount = $\frac{90}{100} \times 1.1x$ $= \$0.99x$ Yes, actual discount of 1%.	M1 A1	2	Correct method to calculate discount
Marker's comment:					

(c)	$\frac{1}{2} \times b \times 0.8h = \frac{1}{2} \times b \times h$ $\frac{b'}{b} = 1.25$ % change = 25%	M1 A1	2	Correct attempt to compare the area of the triangle
Marker's comment:				

5 (ai)	\$60	B1	1	
(aii)	Interquartile range = \$68 - \$50 = \$18	M1 A1	2	
(bi)	$p = 10$ $q = 6$	B1 B1	2	
(bii)	Mean = \$ 61 Std Deviation = $\sqrt{\frac{328000}{80} - (61)^2}$ = \$19.50	B1 M1, A1 Or B2	3	Penalise one mark from question 5 if answers (non-exact) are not to 2d.p.
(c)	Median = \$66 IQR = 70 - 52 = \$18 Students from outdoor club raised more money than soccer club as their median amount is higher . Amount of money collected by both groups of students are equally consistent as their IQR is the same .	B1 B1 B1	3	For obtaining median and IQR ✓ their (ai) and (aii) ✓ their (ai) and (aii)
Marker's comment:				

6 (ai)	$RQ = (3r + 2) + (6r + 1)$ = $9r + 3$	B1	1	
(aii)	$OR = 2(6r + 1) - (3r + 2)$ = $9r$	M1 A1	2	Use radius of large semicircle minus radius of small circle
(b)	$(9r + 3)^2 = (6r + 1)^2 + (9r)^2$ $81r^2 + 54r + 9 = 36r^2 + 12r + 1 + 81r^2$ $36r^2 - 42r - 8 = 0$ $18r^2 - 21r - 4 = 0$ (shown)	B1 B1	2	Form appropriate equation Simplify the equation
(c)	$r = \frac{-(-21) \pm \sqrt{(-21)^2 - 4(18)(-4)}}{2(18)}$ $= \frac{21 \pm \sqrt{729}}{36}$ $= 1\frac{1}{3}$ or $-\frac{1}{6}$ or $(3r - 4)(6r + 1) = 0$ $r = 1\frac{1}{3}$ or $-\frac{1}{6}$	B1 B1 B1 B1 B1	3	Apply quadratic formula Both answers correct, no rejection

(d)	$RQ = 9\left(1\frac{1}{3}\right) + 3 = 15$ cm $OR = 9\left(1\frac{1}{3}\right) = 12$ cm $OR = 9$ cm $\angle OQR = \sin^{-1}\left(\frac{12}{15}\right)$ = 53.1301° $\angle ORQ = \cos^{-1}\left(\frac{12}{15}\right)$ = 36.8699° Area of small sector = $\frac{36.8699}{360} \times (3.142) \times (6)^2 = 11.5845$ cm ² Area of large sector = $\frac{53.1301}{360} \times (3.142) \times 9^2$ = 37.5603 cm ² Area of triangle $OQR = \frac{1}{2} \times 9 \times 12 = 54$ cm ² Area of shaded region = $54 - 37.5603 - 11.5845 = 4.8552$ = 4.86 cm ²	M1 M1 M1 M1	4	Finding one accurate angle in the triangle by use of trigonometry. ✓ their (c) Finding the areas of both sector Finding the area of the triangle ✓ their (c)
Marker's comment:				

7 (ai)	$\overrightarrow{PQ} = \overrightarrow{PO} + \overrightarrow{OQ} = \begin{pmatrix} -5 \\ 5 \end{pmatrix}$ $ \overrightarrow{PQ} = \sqrt{(-5)^2 + (5)^2} = 7.07$ units	M1 A1	2	
(aii)	$\overrightarrow{SP} = 3\overrightarrow{PQ}$ $\overrightarrow{SO} + \overrightarrow{OP} = 3\overrightarrow{PQ}$ $\overrightarrow{SO} = 3\begin{pmatrix} -5 \\ 5 \end{pmatrix} - \begin{pmatrix} 7 \\ 1 \end{pmatrix} = \begin{pmatrix} -22 \\ 14 \end{pmatrix}$ The coordinates of S is (22, -14).	M1 A1	2	✓ their (ai) Answer in coordinate form
(aiii)	$\begin{pmatrix} h+2 \\ 5 \end{pmatrix} = k\overrightarrow{PQ} = k\begin{pmatrix} -5 \\ 5 \end{pmatrix}$ $k = 1$ $h = -7$	B1	1	✓ their (ai)
(bi)(a)	$\overrightarrow{OB} = \overrightarrow{OA} + \overrightarrow{AB}$ = $\overrightarrow{OA} + \overrightarrow{OC}$ = $\underline{p} + \underline{q}$	B1	1	

(bi)(b)	$\overline{AC} = \overline{OC} - \overline{OA}$ $= q - p$ $\overline{OT} = \overline{OA} + \overline{AT}$ $= p + 5\overline{AC}$ $= p + 5(q - p)$ $= 5q - 4p$	M1		For finding \overrightarrow{AC}
(bi)(c)	$\overline{BT} = \overline{OT} - \overline{OB}$ $= 5q - 4p - p - q$ $= 4q - 5p$	B1	1	✓ their (bi)(b)
(bii)	$\overrightarrow{OR} = \overrightarrow{OA} + \overrightarrow{AB} + \overrightarrow{BR}$ $= \frac{9}{5}q$ $\overrightarrow{OC} = \frac{5}{4}\overrightarrow{CR}$ $k = \frac{5}{4}$	M1		For finding \overrightarrow{OR} or \overrightarrow{CR}
(biii)	$\overrightarrow{BR} = \frac{1}{5}\overrightarrow{BT}$ $\frac{\text{area of } \triangle BCR}{\text{area of } \triangle CRT} = \frac{1}{4}$	B1	1	
Marker's comment:				

8 (a)	$p = 3.5$	B1	1	
(b)				
	All points plotted correctly Smooth curve through plotted points Correct scale and axes labelled	P1 C1 B1	3	
(c)	$\frac{1}{2}x^3 - 3x^2 + 7 = -5$ At $y = -5$, there are 3 points of intersection , indicating 3 solutions to the equation.	B1 B1	2	
(d)	Draws tangent at $x = 0.5$ and estimates (change in y) / (change in x) $-2.63 (\pm 0.3)$	M1 A1	2	
(ei)	Line of $y = 2 - x$ drawn	B1	1	
(eii)	$x = -1.05, 1.8, 5.25$ (all values ± 0.1)	B1	1	For all 3 correct answers
(eiii)	$\frac{1}{2}x^3 - 3x^2 + 7 = 2 - x$ $\frac{1}{2}x^3 - 3x^2 + x + 5 = 0$ $x^3 - 6x^2 + 2x + 10 = 0$ $a = -6, b = 2, c = 10$	M1 A1	2	
Marker's comment:				

9	(ai)	$QS^2 = 8.9^2 + 12.5^2 - 2(8.9)(12.5) \cos 53^\circ$ $QS = 10.0775$ $= 10.1 \text{ m}$	M2		
			A1	3	
	(aii)	By Sine Rule, $\frac{\sin \angle QSR}{8.9} = \frac{\sin 53^\circ}{10.0775}$ $\sin \angle QSR = \frac{8.9 \sin 53^\circ}{10.0775}$ $\angle QSR = 44.8554^\circ$ $\approx 44.9^\circ$	M1		Finding angle either using sine or cosine rule
			A1	2	
	(aiii)	Bearing of S from Q = $53^\circ + 44.9^\circ$ $= 097.9^\circ$	B1	1	√ their (ai) No mark if answer is not expressed to 3 digit
	(aiv)	$\frac{1}{2} \times 8.9 \times 12.5 \sin 53^\circ$ $= 44.4 \text{ m}^2$	M1		
			A1	2	
	(av)	$\tan 27^\circ = \frac{PQ}{8.9}$ $PQ = 4.53 \text{ m}$	M1		Appropriate trigo ratio
			A1	2	
	(b)	Shortest distance from Q to RS $= \frac{44.424}{2} = 7.10785 \text{ m}$ $\frac{1}{2} \times 12.5$ or $= 8.9 \sin 53^\circ = 7.10785 \text{ m}$ $\tan \theta = \frac{4.5347}{7.10785}$ $\theta = 32.5^\circ$	M1		For finding perpendicular distance √ their (av)
			A1	2	
Marker's Comments:					

10	(a)	Vertical height of trapezium = $2 - 0.5$ $= 1.5 \text{ m}$ Length of shorter side = $0.5 \times 2 = 1 \text{ m}$ Length of longer side = $1.0 \times 2 = 2 \text{ m}$	B1		
			B1	2	For both correct parallel lengths
	(b)	Volume of half of cylinder $= \pi(0.5)^2 \times 10 \times \frac{1}{2}$ $= 3.9275 \text{ m}^3$ Volume of the trapezoid $= \frac{1}{2} \times (1+2) \times 1.5 \times 10$ $= 22.5 \text{ m}^3$ Volume of the drain = $22.5 + 3.9275$ $= 26.4275$ $= 26.4 \text{ m}^3$	M1		√ for their length in (a)
			M1		√ for their length in (a) Apply volumes of cylinder and trapezium
			M1	4	
			A1		
	(c)	90% volume of water = $26.4275 \times \frac{90}{100}$ $= 23.785 \text{ m}^3$ 48000 litres per min = $\frac{48000}{1000 \times 60}$ $= 0.8 \text{ m}^3/\text{s}$ Time taken to drain the volume of water $= \frac{23.785}{0.8}$ $= 29.73125 \text{ s}$ Since the time taken to channel water is 29.73s which is < 30s, there is no need to set up preventive measures. <i>Alternative method of determination can be based on whether the canal can hold the stated volume of water during the storm.</i>	M1		√ for their volume in (b) Use the appropriate non-linear info such as 90%
		M1		For comparing the rate of flow based on same time interval	
		M1		Using either time taken to drain or volume it can hold as a means of checking	
		A1	4	Make judgement based on sound mathematical calculations * All M1 awarded for correct method regardless of accuracy.	
Marker's Comments:					