

*Visit*

**FREETESTPAPER.com**

*for more papers*



Website: [freetestpaper.com](http://www.freetestpaper.com)



[Facebook.com/freetestpaper](https://www.facebook.com/freetestpaper)



[Twitter.com/freetestpaper](https://www.twitter.com/freetestpaper)

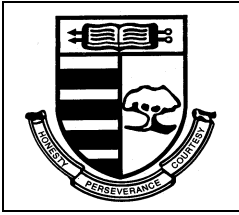

CEDAR GIRLS' SECONDARY SCHOOL  
Preliminary Examination  
Secondary Four

CANDIDATE  
NAME

	Sec 4 ( ) Reg. No: ( )
--	------------------------

CENTRE  
NUMBER

--	--	--	--

INDEX  
NUMBER

--	--	--	--

**MATHEMATICS**

Paper 1

**4048/01**

15 August 2018

2 hours

Candidates answer on the Question Paper.

**READ THESE INSTRUCTIONS FIRST**

Write your Centre number, index number and name on all the work you hand in.

Write in dark blue or black pen.

You may use a pencil for any diagrams or graphs.

Do not use staples, paper clips, highlighters, glue or correction fluid.

DO **NOT** WRITE IN ANY BARCODES.

Answer **all** questions.

If working is needed for any question, it must be shown with the answer.

Omission of essential working will result in loss of marks.

The use of an approved scientific calculator is expected, where appropriate.

If the degree of accuracy is not specified in the question, and if the answer is not exact, give the answer to three significant figures. Give answers in degrees to one decimal place.

For  $\pi$ , use either your calculator value or 3.142, unless the question requires the answer in terms of  $\pi$ .

At the end of the examination, fasten all your work securely together.

The number of marks is given in brackets [ ] at the end of each question or part question.

The total number of marks for this paper is 80.

<b>For Examiner's Use</b>
<b>80</b>

**Mathematical Formulae***Compound interest*

$$\text{Total amount} = P \left( 1 + \frac{r}{100} \right)^n$$

*Mensuration*

$$\text{Curved surface area of a cone} = \pi r l$$

$$\text{Surface area of a sphere} = 4\pi r^2$$

$$\text{Volume of a cone} = \frac{1}{3} \pi r^2 h$$

$$\text{Volume of a sphere} = \frac{4}{3} \pi r^3$$

$$\text{Area of triangle } ABC = \frac{1}{2} ab \sin C$$

$$\text{Arc length} = r\theta, \text{ where } \theta \text{ is in radians}$$

$$\text{Sector area} = \frac{1}{2} r^2 \theta, \text{ where } \theta \text{ is in radians}$$

*Trigonometry*

$$\frac{a}{\sin A} = \frac{b}{\sin B} = \frac{c}{\sin C}$$

$$a^2 = b^2 + c^2 - 2bc \cos A$$

*Statistics*

$$\text{Mean} = \frac{\sum fx}{\sum f}$$

$$\text{Standard deviation} = \sqrt{\frac{\sum fx^2}{\sum f} - \left( \frac{\sum fx}{\sum f} \right)^2}$$

Answer **all** the questions.

1 (a) Expand and simplify  $(2x - 1)(2 - 3x) - 3x(2x - 5)$ .

Answer ..... [2]

(b) Factorise completely  $24ab - 4ac + pc - 6pb$ .

Answer ..... [2]

---

2 Solve the equation  $2^{3x} \times 125^x = 100$ .

Answer  $x =$  ..... [3]

For  
Examiner's  
Use

For  
Examiner's  
Use

3

 $A = \{\text{points lying on the line } 2x + y = 8\}$ 
 $B = \{\text{points lying on the line } 3x - 4y = 12\}$ 
 $C = \{\text{points lying on the line } mx - 4y = c\}$ 

(a) Is  $(-1, 6) \in A$ ? Explain clearly.

Answer

\_\_\_\_\_ [1]

(b) Find the element  $p$  such that  $p \in (A \cap B)$ .

Answer  $p =$  \_\_\_\_\_ [2]

(c) Write down a possible value of  $m$  and of  $c$  such that  $B \cap C = \emptyset$ .

Answer  $m =$  \_\_\_\_\_ [1]

$c =$  \_\_\_\_\_ [1]

4 (a) Solve the inequalities  $8 + x < 10 + \frac{3}{2}x \leq 15.5 - 2x$ .

Answer ..... [3]

(b) Write down the largest rational number that satisfies  
 $8 + x < 10 + \frac{3}{2}x \leq 15.5 - 2x$ .

Answer ..... [1]

5 Integers  $P$  and  $Q$ , written as products of their prime factors, are  
 $P = 2^2 \times 3 \times k^2$  and  $Q = 2^3 \times 7 \times k$ , where  $k$  is a prime number.

(a) Express, in terms of  $k$  and as a product of its prime factors, the smallest integer which is divisible by both  $P$  and  $Q$ .

Answer ..... [1]

(b) Find the smallest integer,  $n$ , such that  $(27k)n$  is a multiple of  $P$ .  
 Give your answer in terms of  $k$  **if necessary**.

Answer  $n =$  ..... [1]

- 6 The diagram shows the curve  $y = x^2 + ax + b$  and the line  $y = mx + c$  which intersect at  $A$  on the  $y$ -axis and  $D$ . The curve intersects the  $x$ -axis at  $B$  and  $C$ . The coordinates of  $D$  are  $(6, p)$ .

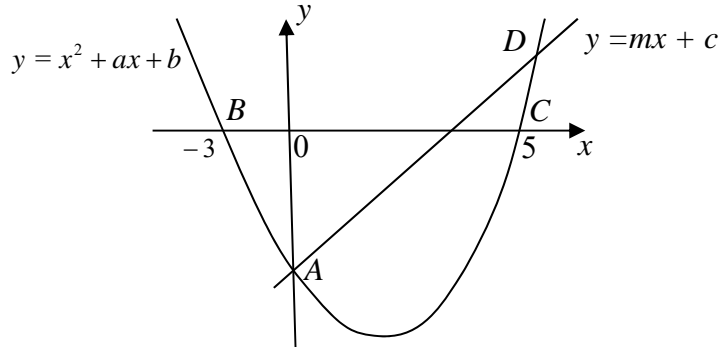

- (a) Find the value of  $a$  and of  $b$ .

Answer  $a =$  \_\_\_\_\_ [1]

$b =$  \_\_\_\_\_ [1]

- (b) Find the value of  $p$ .

Answer  $p =$  \_\_\_\_\_ [1]

- (c) Find the equation of the line parallel to  $BD$  and passing through  $C$ .

Answer \_\_\_\_\_ [2]

- (d) Find the coordinates of  $E$  such that  $ABCE$  is a parallelogram.

Answer \_\_\_\_\_ [2]

For  
Examiner's  
Use

For  
Examiner's  
Use

- 7  $y$  is inversely proportional to the square root of  $x$  and the difference in the values of  $y$  when  $x = 9$  and when  $x = 16$  is 3.

Find

- (a) an equation connecting  $x$  and  $y$ ,

Answer \_\_\_\_\_ [3]

- (b) the exact value of  $x$  when  $y = 5$ .

Answer  $x =$  \_\_\_\_\_ [1]

- 8 Jon travels at 20 km/h for 50% of the journey and 25 km/h for the rest of the journey.  
Calculate Jon's average speed, in km/h for the whole journey.

Answer \_\_\_\_\_ km/h [3]

- 9 The point (1,1) is marked on each diagram in the answer space below.  
Sketch, for  $x > 0$ , the graph of

(a)  $y = 3^x$ ,

Answer

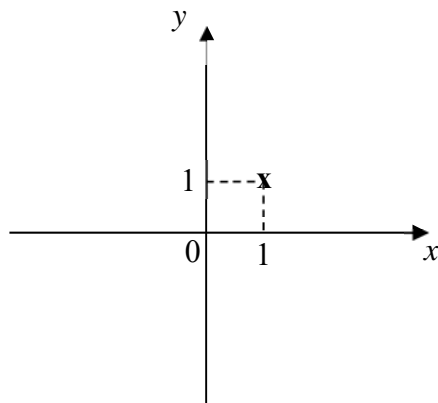

[1]

(b)  $y = \frac{2}{x}$ .

Answer

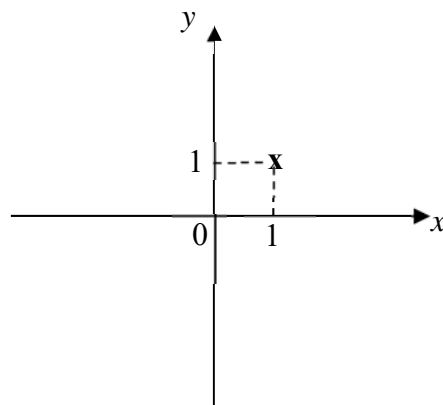

[1]

- 10** Vehicles approaching a crossroad may go in one of these directions: left, right or straight ahead.

If the probability of a vehicle turning left is  $\frac{7}{20}$ , the probability of it turning right is  $\frac{9}{20}$  and the probability of it going straight ahead is  $\frac{1}{5}$ , calculate the probability that for any three vehicles approaching the crossroads,

- (a) all will go straight,

Answer \_\_\_\_\_ [1]

- (b) at least one will turn right.

Answer \_\_\_\_\_ [2]

- 11** In the diagram,  $PQ$  is parallel to  $RS$ ,  $RQ = RS$  and reflex  $\angle QRS = 290^\circ$ . Calculate the value of

- (a)  $x$ ,

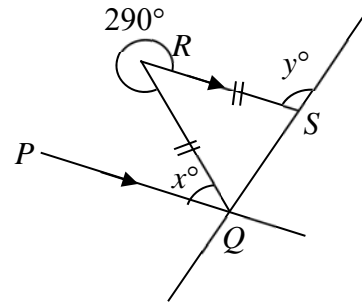

Answer  $x =$  \_\_\_\_\_ [1]

- (b)  $y$ .

Answer  $y =$  \_\_\_\_\_ [2]

**12** The cash price of a computer is \$2 750. Mr Ong bought the computer by paying a 30% downpayment and monthly instalments of \$90 over 2 years.

**(a)** How much is the downpayment?

Answer \$ \_\_\_\_\_ [1]

**(b)** Calculate the total amount Mr Ong paid for the computer.

Answer \$ \_\_\_\_\_ [2]

**(c)** Find the flat rate of interest per annum for the instalments.

Answer \_\_\_\_\_ % [3]

**13** On a certain day, the exchange rate between the pound (£) and the Singapore dollar (S\$) was S\$1.95 = £1.

**(a)** Calculate the amount of pounds which May can buy with S\$1170.

Answer £ \_\_\_\_\_ [1]

**(b)** After four weeks, she realised she has too much pounds and she now wants to change £200 back to Singapore dollars.

If the loss by this transaction is \$6, what is the current exchange rate?

Answer £1= S\$ \_\_\_\_\_ [2]

- 14 (a) The perimeter of a rectangular lawn is 72 m and its area is 323 m<sup>2</sup>. Calculate the length of a diagonal of the lawn, without solving for its length and breadth.

Answer \_\_\_\_\_ m [4]

- (b) Another rectangular lawn is 18 m long and 7 m wide, correct to the nearest metre. Find the greatest possible area of this lawn.

Answer \_\_\_\_\_ m<sup>2</sup> [1]

- 15 A right circular cone is divided into 3 portions, X, Y and Z, as shown in the diagram below. The height of each portion is 1 unit. Calculate volume of Y : volume of Z.

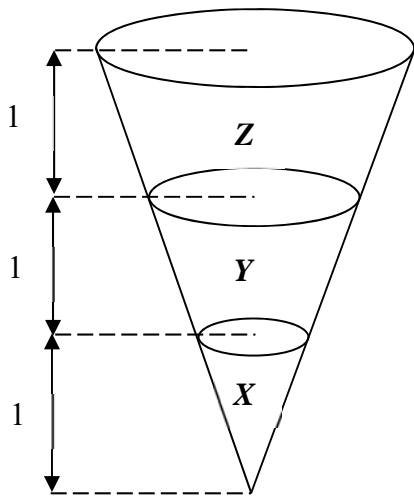

Answer \_\_\_\_\_ : \_\_\_\_\_ [3]

16 On the grid in the answer space,  $\overrightarrow{OP} = \mathbf{p}$ ,  $\overrightarrow{OQ} = \mathbf{q}$ .  
The point  $R$  is also marked.

(a) Draw and label clearly on the grids below, the vector,  $\overrightarrow{OS}$ ,  
such that  $\overrightarrow{OS} = \mathbf{p} + 2\mathbf{q}$ .

Answer (a)

[1]

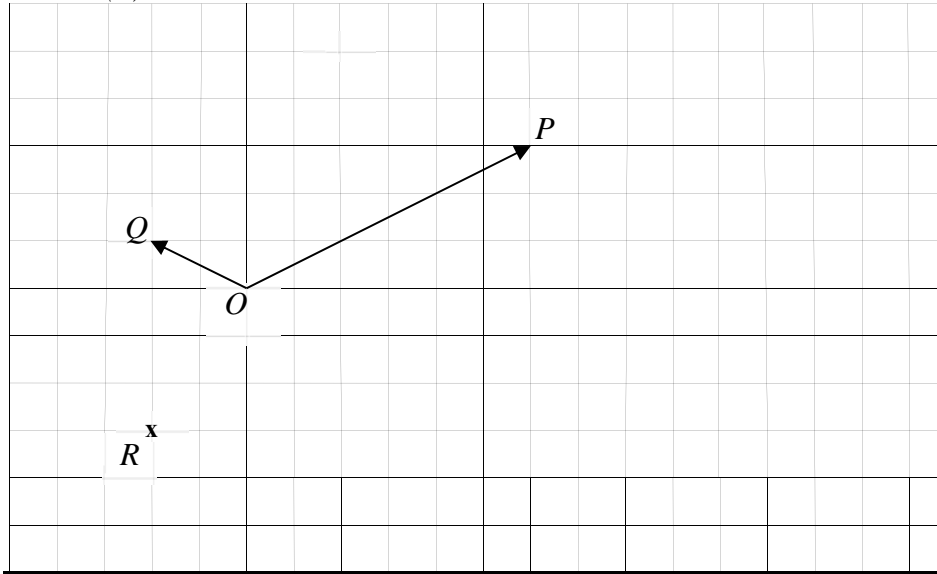

(b) Express  $\overrightarrow{OR}$  in terms of  $\mathbf{p}$  and / or  $\mathbf{q}$ .

Answer \_\_\_\_\_ [1]

(c) If the length of each small square is 1 unit, calculate  $|\overrightarrow{OS}|$ .

Answer \_\_\_\_\_ unit [2]

17 (a) Calculate the size of an exterior angle of a regular polygon with 12 sides.

Answer \_\_\_\_\_ [1]

(b) Tile  $P$  is in the shape of a regular 12-sided polygon.  
Explain, showing your working clearly, whether tiles  $P$  will fit together on the floor without gaps.

Answer

\_\_\_\_\_  
\_\_\_\_\_ [2]

18 On a map, a straight road measuring 600 m is represented by a line segment of length 7.5 cm.

(a) Express the scale of the map in the ratio  $1 : r$ .

Answer 1 : \_\_\_\_\_ [1]

(b) The length of a canal on the map is 25 cm. Find the actual length in km.

Answer \_\_\_\_\_ km [1]

(c) The actual area of a school is 22 400 m<sup>2</sup>. Find the area of the school on the map.

Answer \_\_\_\_\_ cm<sup>2</sup> [2]

- 19  $ABC$  is a triangle in which  $AC = 13$  cm,  $BC = 11$  cm and  $AB = 20$  cm.  
 $P$  is a point on  $BC$  produced, where  $CP = 5$  cm and  $AP = 12$  cm.

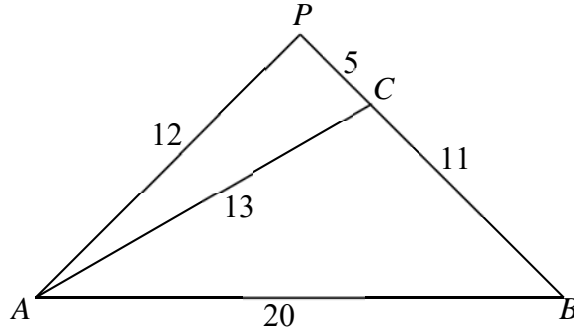

- (a) Explain why  $\angle APB = 90^\circ$ .  
 Answer

---



---

[2]

- (b) Expressing your answer as a fraction in its simplest form, find  
 $\frac{\tan \angle ABC}{\cos \angle ACB}$ .

Answer \_\_\_\_\_ [3]

For  
Examiner's  
Use

For  
Examiner's  
Use

- 20** The graph shows the number of accidents occurring at a road junction over a number of years.  
State one aspect of the graph that may be misleading and explain how this may lead to a misinterpretation of the graph.

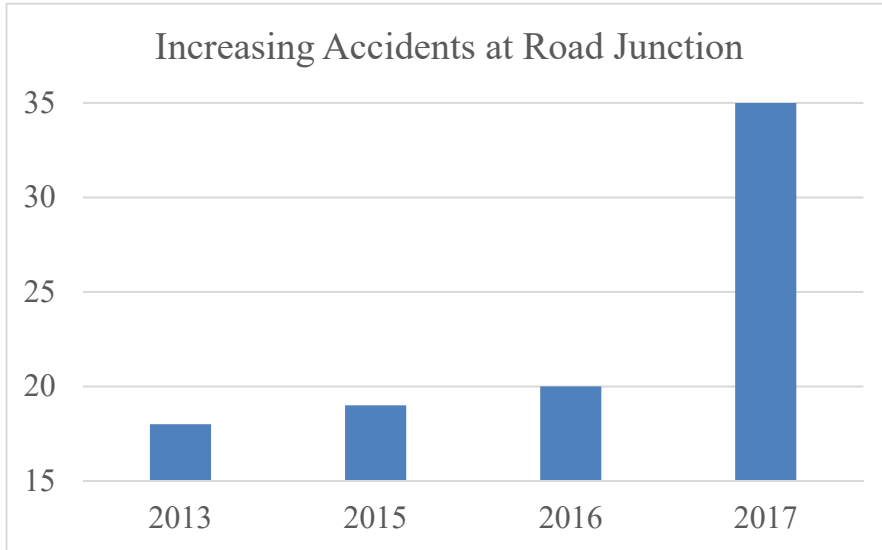

*Answer*

---

---

[2]

- 21 The diagram shows the speed-time graph of a lorry. The lorry starts from rest and accelerates uniformly to a speed of 15m/s in 10 seconds. The lorry then travels at a constant speed for some time before it decelerates uniformly at  $0.75 \text{ m/s}^2$  until it comes to rest. The whole journey takes one minute.

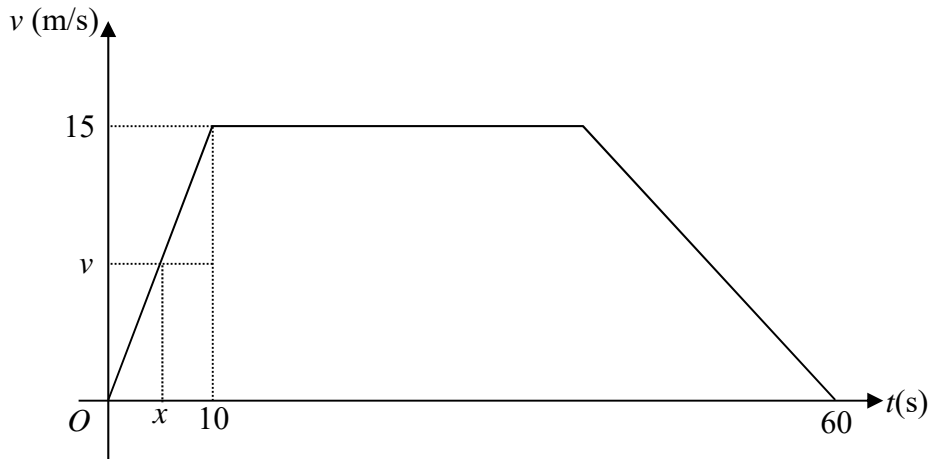

- (a) Given that the speed after  $x$  seconds is  $v$  m/s, express  $v$  in terms of  $x$ .

Answer  $v =$  \_\_\_\_\_ [1]

- (b) For how long does the lorry travel at the maximum speed ?

Answer \_\_\_\_\_ s [2]

- (c) Calculate the total distance travelled by the lorry during this 1 minute journey.

Answer \_\_\_\_\_ m [2]

**End of Paper**



**CEDAR GIRLS' SECONDARY SCHOOL**  
**SECONDARY 4 MATHEMATICS**  
**Answer Key for 2018 Preliminary Examination 2**

<b>PAPER 4048/1</b>			
<b>1a</b>	$-12x^2 + 22x - 2$	<b>15</b>	7 : 19
<b>1b</b>	$(6b - c)(4a - p)$	<b>16b</b>	$-\frac{2}{3}p - q$
<b>2</b>	$x = \frac{2}{3}$	<b>16c</b>	5.39 unit
<b>3a</b>	LHS $\neq$ RHS. $(-1, 6)$ does not satisfy the equation so $(-1, 6) \notin A$ .	<b>17a</b>	$30^\circ$
<b>3b</b>	$(4, 0)$	<b>17b</b>	$\frac{360}{150} = 2.4$ which is not a positive integer so the tiles will not fit together on the floor without gaps.
<b>3c</b>	$m = 3, c = 1 (c \neq 12)$		
<b>4a</b>	$-4 < x \leq 1\frac{4}{7}$	<b>18a</b>	1:8000
<b>4b</b>	$1\frac{4}{7}$	<b>18b</b>	2 km
<b>5a</b>	$2^3 \times 3 \times 7 \times k^2$	<b>18c</b>	$3.5 \text{ cm}^2$
<b>5b</b>	$n = 4k$	<b>19a</b>	By converse of Pythagoras' Theorem, $\triangle APC$ is a right-angled $\triangle$ . So $\angle APB = 90^\circ$ .
<b>6a</b>	$a = -2, b = -15$	<b>19b</b>	$-39/20$
<b>6b</b>	$p = 9$	<b>20</b>	The vertical axis did not start from 0, giving an exaggerated difference between the bars. (Any other sensible reasons.)
<b>6c</b>	$y = x - 5$	<b>21a</b>	$v = 1.5x$
<b>6d</b>	$E = (8, -15)$	<b>21b</b>	30 s
<b>7a</b>	$y = \frac{36}{\sqrt{x}}$	<b>21c</b>	675 m
<b>7b</b>	$x = 51\frac{21}{25}$	<b>9a</b>	
<b>8</b>	22.2 km/h	<b>9b</b>	
<b>10a</b>	$\frac{1}{125}$		
<b>10b</b>	0.834		
<b>11a</b>	$\angle x = 70^\circ$		
<b>11b</b>	$\angle y = 125^\circ$		
<b>12a</b>	\$825		
<b>12b</b>	\$2 985		
<b>12c</b>	6.10%		
<b>13a</b>	£600		
<b>13b</b>	£1 = S\$ 1.92		
<b>14a</b>	25.5 m		
<b>14b</b>	$138.75 \text{ m}^2$		



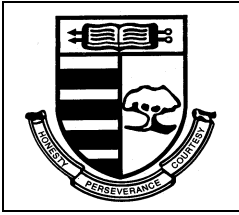

CEDAR GIRLS' SECONDARY SCHOOL  
Preliminary Examination  
Secondary Four

CANDIDATE  
NAME

	Sec 4 ( ) Reg. No: ( )
--	------------------------

CENTRE  
NUMBER

--	--	--	--

INDEX  
NUMBER

--	--	--	--

**MATHEMATICS(MARK SCHEME)**

Paper 1

**4048/01**

15 August 2018

2 hours

Candidates answer on the Question Paper.

**READ THESE INSTRUCTIONS FIRST**

Write your Centre number, index number and name on all the work you hand in.

Write in dark blue or black pen.

You may use a pencil for any diagrams or graphs.

Do not use staples, paper clips, highlighters, glue or correction fluid.

DO **NOT** WRITE IN ANY BARCODES.

Answer **all** questions.

If working is needed for any question, it must be shown with the answer.

Omission of essential working will result in loss of marks.

The use of an approved scientific calculator is expected, where appropriate.

If the degree of accuracy is not specified in the question, and if the answer is not exact, give the answer to three significant figures. Give answers in degrees to one decimal place.

For  $\pi$ , use either your calculator value or 3.142, unless the question requires the answer in terms of  $\pi$ .

At the end of the examination, fasten all your work securely together.

The number of marks is given in brackets [ ] at the end of each question or part question.

The total number of marks for this paper is 80.

<b>For Examiner's Use</b>
<b>80</b>

**Mathematical Formulae***Compound interest*

$$\text{Total amount} = P \left( 1 + \frac{r}{100} \right)^n$$

*Mensuration*

$$\text{Curved surface area of a cone} = \pi r l$$

$$\text{Surface area of a sphere} = 4\pi r^2$$

$$\text{Volume of a cone} = \frac{1}{3} \pi r^2 h$$

$$\text{Volume of a sphere} = \frac{4}{3} \pi r^3$$

$$\text{Area of triangle } ABC = \frac{1}{2} ab \sin C$$

$$\text{Arc length} = r\theta, \text{ where } \theta \text{ is in radians}$$

$$\text{Sector area} = \frac{1}{2} r^2 \theta, \text{ where } \theta \text{ is in radians}$$

*Trigonometry*

$$\frac{a}{\sin A} = \frac{b}{\sin B} = \frac{c}{\sin C}$$

$$a^2 = b^2 + c^2 - 2bc \cos A$$

*Statistics*

$$\text{Mean} = \frac{\sum fx}{\sum f}$$

$$\text{Standard deviation} = \sqrt{\frac{\sum fx^2}{\sum f} - \left( \frac{\sum fx}{\sum f} \right)^2}$$

Answer **all** the questions.

- 1 (a) Expand and simplify  $(2x-1)(2-3x)-3x(2x-5)$ .

$$\begin{aligned} & (2x-1)(2-3x)-3x(2x-5) \\ & = 4x-6x^2-2+3x-6x^2+15x \\ & = -12x^2+22x-2 \end{aligned}$$

Answer  $-12x^2+22x-2$  [2]

- (b) Factorise completely  $24ab-4ac+pc-6pb$ .

$$\begin{aligned} & 24ab-4ac+pc-6pb \\ & = 4a(6b-c)+p(c-6b) \\ & = 4a(6b-c)-p(6b-c) \\ & = (6b-c)(4a-p) \\ & \text{or } (c-6b)(p-4a) \end{aligned}$$

Answer  $(6b-c)(4a-p)$  [2]

- 2 Solve the equation  $2^{3x} \times 125^x = 100$ .

$$\begin{aligned} 2^{3x} \times 125^x & = 100 \\ 2^{3x} \times 5^{3x} & = 10^2 \\ 10^{3x} & = 10^2 \\ 3x & = 2 \\ x & = \frac{2}{3} \end{aligned}$$

Answer  $x = \frac{2}{3}$  [3]

3

$$A = \{\text{points lying on the line } 2x + y = 8\}$$

$$B = \{\text{points lying on the line } 3x - 4y = 12\}$$

$$C = \{\text{points lying on the line } mx - 4y = c\}$$

(a) Is  $(-1, 6) \in A$ ? Explain clearly.*Answer*Substitute  $(-1, 6)$ , LHS =  $2(-1) + 6 = 4$ , RHS = 8.LHS  $\neq$  RHS.  $(-1, 6)$  does not satisfy the equation so  $(-1, 6) \notin A$ . [1](b) Find the element  $p$  such that  $p \in (A \cap B)$ .

$$2x + y = 8 \dots\dots\dots(1)$$

$$3x - 4y = 12 \dots\dots\dots(2)$$

From (1):  $y = -2x + 8$  into (2)

$$3x - 4(8 - 2x) = 12$$

$$3x - 32 + 8x = 12$$

$$11x = 44$$

$$x = 4$$

$$y = 0$$

Answer  $p = (4, 0)$  [2](c) Write down a possible value of  $m$  and of  $c$  such that  $B \cap C = \emptyset$ .

$$y = \frac{3}{4}x - 3 \quad \text{and} \quad y = \frac{mx}{4} - \frac{c}{4}$$

Since  $B \cap C = \emptyset$ 

$$\frac{m}{4} = \frac{3}{4}$$

$$m = 3$$

$$-\frac{c}{4} = -3$$

$$c = 12$$

Answer  $m = 3$  [1] $c = \underline{\text{Any real value}} \neq 12$  [1]

- 4 (a) Solve the inequalities  $8 + x < 10 + \frac{3}{2}x \leq 15.5 - 2x$ .

$$8 + x < 10 + \frac{3}{2}x \quad \text{and} \quad 10 + \frac{3}{2}x \leq 15.5 - 2x$$

$$8 + x < 10 + \frac{3}{2}x \quad \text{and} \quad \frac{7}{2}x \leq 5.5$$

$$-\frac{1}{2}x < 2 \quad \text{and} \quad x \leq \frac{11}{7}$$

$$x > -4 \quad \text{and} \quad x \leq \frac{11}{7}$$

$$-4 < x \leq \frac{11}{7} \quad \text{or} \quad 1\frac{4}{7}$$

Answer  $\underline{-4 < x \leq 1\frac{4}{7}}$  [3]

- (b) Write down the largest rational number that satisfies

$$8 + x < 10 + \frac{3}{2}x \leq 15.5 - 2x.$$

Greatest rational value of  $x$  is  $1\frac{4}{7}$ .

Answer  $\underline{1\frac{4}{7}}$  [1]

- 5 Integers  $P$  and  $Q$ , written as products of their prime factor, are  
 $P = 2^2 \times 3 \times k^2$  and  $Q = 2^3 \times 7 \times k$ , where  $k$  is a prime number.

- (a) Express, in terms of  $k$  and as a product of its prime factors, the smallest integer which is divisible by both  $P$  and  $Q$ .

$$\text{LCM} = 2^3 \times 3 \times 7 \times k^2$$

Answer  $\underline{2^3 \times 3 \times 7 \times k^2}$  [1]

- (b) Find the smallest integer,  $n$ , such that  $(27k)n$  is a multiple of  $P$ .  
 Give your answer in terms of  $k$  **if necessary**.

$$27kn = m(2^2 \times 3 \times k^2)$$

$$n = 2^2 \times k$$

$$n = 4k$$

Answer  $n = \underline{4k}$  [1]

- 6 The diagram shows the curve  $y = x^2 + ax + b$  and the line  $y = mx + c$  which intersect at  $A$  on the  $y$ -axis and  $D$ .  
The curve intersects the  $x$ -axis at  $B$  and  $C$ . The coordinates of  $D$  are  $(6, p)$ .

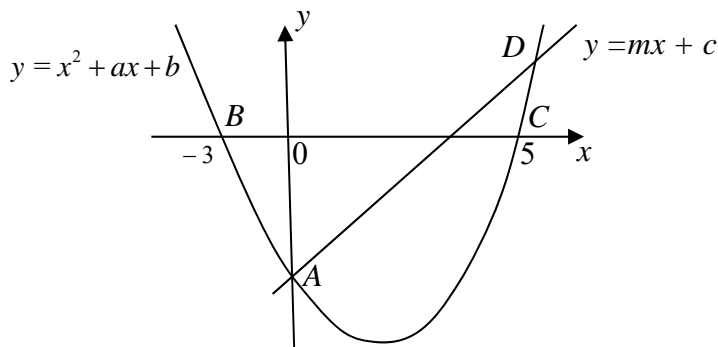

- (a) Find the value of  $a$  and of  $b$ .

$$y = (x+3)(x-5)$$

$$y = x^2 - 2x - 15$$

Answer  $a = \underline{-2}$  [1]

$b = \underline{-15}$  [1]

- (b) Find the value of  $p$ .

$$y = (x+3)(x-5)$$

At  $D(6, p)$ ,

$$p = (6+3)(6-5) = 9$$

Answer  $p = \underline{9}$  [1]

- (c) Find the equation of the line parallel to  $BD$  and passing through  $C$ .

$$\text{Gradient of } BD = \frac{9-0}{6-(-3)} = 1$$

Equation of line is  $y = x + c$

At  $C(5, 0)$

Equation is  $y = x - 5$

Answer  $\underline{y = x - 5}$  [2]

- (d) Find the coordinates of  $E$  such that  $ABCE$  is a parallelogram.

Since  $BC$  is on the  $x$ -axis,  $y$ -coordinate of  $E$  is  $-15$

Midpoint of  $AC$  = Midpoint of  $BE$

$$0+5 = x-3$$

$$x = 8$$

$$E = (8, -15)$$

Answer  $\underline{(8, -15)}$  [2]

- 7  $y$  is inversely proportional to the square root of  $x$  and the difference in the values of  $y$  when  $x = 9$  and when  $x = 16$  is 3.

Find

- (a) an equation connecting  $x$  and  $y$ ,

$$y = \frac{k}{\sqrt{x}}$$

$$\text{When } x = 9, \quad y_1 = \frac{k}{3}$$

$$\text{When } x = 16, \quad y_2 = \frac{k}{4}$$

$$\frac{k}{3} - \frac{k}{4} = 3$$

$$\frac{4k - 3k}{12} = 3$$

$$k = 36$$

$$\therefore y = \frac{36}{\sqrt{x}}$$

Answer  $y = \frac{36}{\sqrt{x}}$  [3]

- (b) the exact value of  $x$  when  $y = 5$ .

$$5 = \frac{36}{\sqrt{x}}$$

$$x = \frac{1296}{25} = 51\frac{21}{25}$$

Answer  $x = 51\frac{21}{25}$  [1]

- 8 Jon travels at 20 km/h for 50% of the journey and 25 km/h for the rest of the journey.

Calculate Jon's average speed, in km/h for the whole journey.

Let  $x$  km : the distance

$$\begin{aligned} & \frac{x}{\frac{0.5x}{20} + \frac{0.5x}{25}} \\ &= \frac{x}{\frac{2.5x + 2x}{100}} \\ &= \frac{100}{4.5} = 22.2 \end{aligned}$$

Answer 22.2 km/h [3]

- 9 The point (1,1) is marked on each diagram in the answer space below. Sketch, for  $x > 0$ , the graph of

(a)  $y = 3^x$ ,

Answer

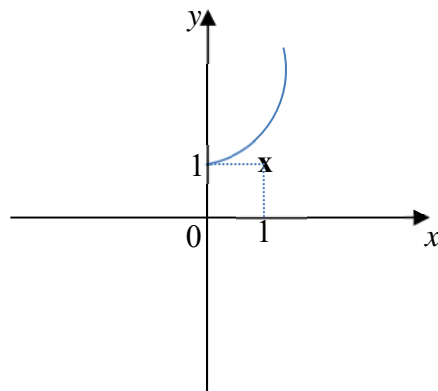

[1]

(b)  $y = \frac{2}{x}$ .

Answer

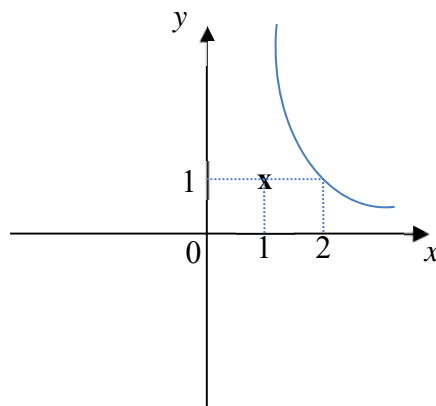

[1]

- 10 Vehicles approaching a crossroad may go in one of these directions: left, right or straight ahead.

If the probability of a vehicle turning left is  $\frac{7}{20}$ , the probability of it turning right is  $\frac{9}{20}$  and the probability of it going straight ahead is  $\frac{1}{5}$ , calculate the probability that for any three vehicles approaching the crossroads,

- (a) all will go straight,

$$\frac{1}{5} \times \frac{1}{5} \times \frac{1}{5} = \frac{1}{125}$$

Answer  $\frac{1}{125}$  [1]

- (b) at least one will turn right.

$$1 - \left(\frac{11}{20}\right)\left(\frac{11}{20}\right)\left(\frac{11}{20}\right) \\ = 0.83362$$

Answer 0.834 [2]

- 11 In the diagram,  $PQ$  is parallel to  $RS$ ,  $RQ = RS$  and reflex  $\angle QRS = 290^\circ$ . Calculate the value of

- (a)  $x$ ,  
Acute  $\angle QRS = 360^\circ - 290^\circ$  ( $\angle$ s at a point)  
 $= 70^\circ$   
 $\therefore \angle x = 70^\circ$  (alt.  $\angle$ s,  $RS$  parallel to  $PQ$ )

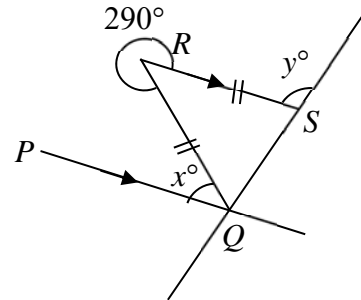

Answer  $x = 70$  [1]

- (b)  $y$ .

$$\angle RSQ = (180^\circ - 70^\circ) \div 2 \text{ (base } \angle \text{ of isos. } \Delta) \\ = 55^\circ \\ \angle y = 180^\circ - 55^\circ \text{ (adj. } \angle \text{ s on a straight line)} \\ = 125^\circ$$

Answer  $y = 125$  [2]

- 12 The cash price of a computer is \$2 750. Mr Ong bought the computer by paying a 30% downpayment and monthly instalments of \$90 over 2 years.

- (a) How much is the downpayment?

$$\begin{aligned}\text{Downpayment} &= \frac{30}{100} \times 2750 \\ &= \$825\end{aligned}$$

Answer \$ 825 [1]

- (b) Calculate the total amount Mr Ong paid for the computer.

$$\begin{aligned}\text{Total amount paid} &= 825 + 90(12)(2) \\ &= 825 + 2160 \\ &= \$2\,985\end{aligned}$$

Answer \$ 2 985 [2]

- (c) Find the flat rate of interest per annum for the instalments.

$$\begin{aligned}\text{Loan} &= \$ (2750 - 825) = \$1\,925 \\ \text{Interest} &= \$ (2160 - 1925) = \$235\end{aligned}$$

$$\text{S. I.} = \frac{1925 \times R \times 2}{100}$$

$$R = \frac{235 \times 100}{1925 \times 2}$$

$$= 6.1038$$

$$= 6.10 \text{ (3sf)}$$

Answer 6.10 % [3]

- 13 On a certain day, the exchange rate between the pound (£) and the Singapore dollar (S\$) was S\$1.95 = £1.

- (a) Calculate the amount of pounds which May can buy with S\$1170.

$$\$1.95 = \text{£}1$$

$$\$1170 = \text{£} \frac{1170}{1.95} = \text{£}600$$

Answer £ 600 [1]

- (b) After four weeks, she realised she has too much pounds and she now wants to change £200 back to Singapore dollars.

If the loss by this transaction is \$6, what is the current exchange rate?

$$\text{Old rate : } \text{£}200 = \$200 \times 1.95 = \$390$$

$$\text{If new rate is } \text{£}1 = \$x, \quad \text{£}200 = \$200x$$

$$390 - 200x = 6$$

$$x = 1.92$$

Answer £1 = S\$ 1.92 [2]

- 14 (a) The perimeter of a rectangular lawn is 72 m and its area is 323 m<sup>2</sup>. Calculate the length of a diagonal of the lawn, without solving for its length and breadth.

$$\begin{aligned} 2(L + B) &= 72 \\ L + B &= 36 \\ LB &= 323 \\ (L + B)^2 &= L^2 + B^2 + 2(LB) \\ 36^2 &= L^2 + B^2 + 2(323) \\ L^2 + B^2 &= 1296 - 646 \\ &= 650 \\ \text{Length of diagonal} &= \sqrt{650} = 25.495 \text{ m} \end{aligned}$$

Answer 25.5 m [4]

- (b) Another rectangular lawn is 18 m long and 7 m wide, correct to the nearest metre. Find the greatest possible area of this lawn.

$$18.5 \times 7.5 = 138.75$$

Answer 138.75 m<sup>2</sup> [1]

- 15 A right circular cone is divided into 3 portions, X, Y and Z, as shown in the diagram below. The height of each portion is 1 unit. Calculate volume of Y : volume of Z.

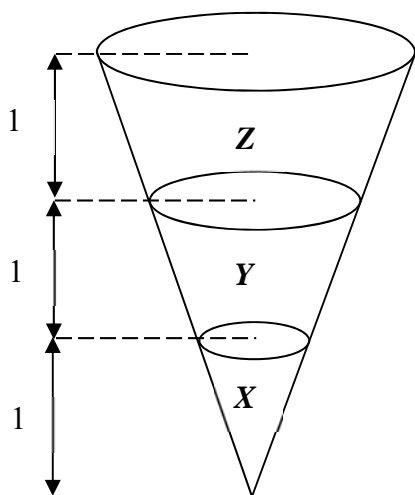

$$\frac{\text{volume of X}}{\text{volume of X + Y}} = \left(\frac{1}{2}\right)^3 = \frac{1}{8}$$

$$\frac{\text{volume of X}}{\text{volume of X + Y + Z}} = \left(\frac{1}{3}\right)^3 = \frac{1}{27}$$

$$\frac{\text{volume of Y}}{\text{volume of Z}} = \frac{7}{19}$$

Answer 7 : 19 [3]

For  
Examiner's  
Use

For  
Examiner's  
Use

16 On the grid in the answer space,  $\overrightarrow{OP} = \mathbf{p}$ ,  $\overrightarrow{OQ} = \mathbf{q}$ .  
The point  $R$  is also marked.

(a) Draw and label clearly on the grids below, the vector,  $\overrightarrow{OS}$ ,  
such that  $\overrightarrow{OS} = \mathbf{p} + 2\mathbf{q}$ .

Answer (a)

[1]

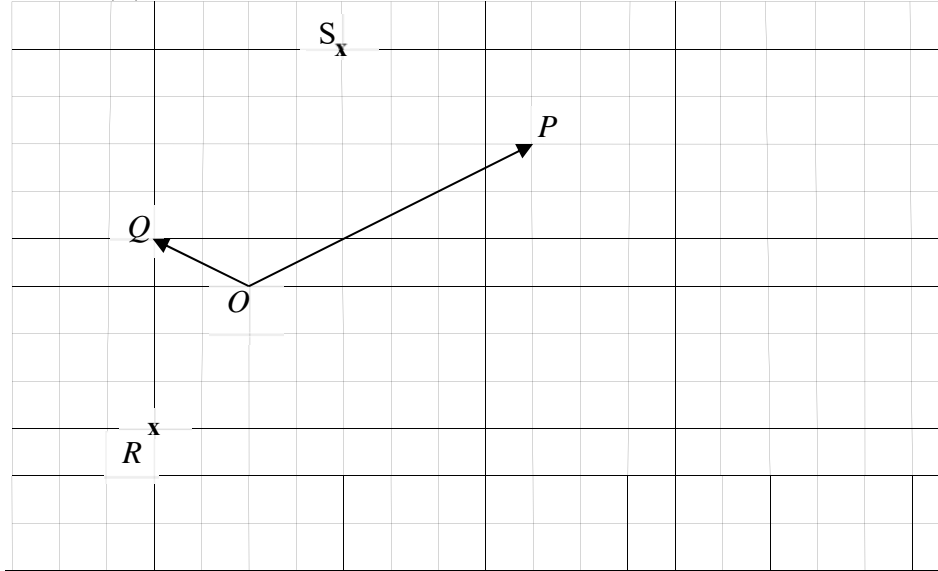

(b) Express  $\overrightarrow{OR}$  in terms of  $\mathbf{p}$  and / or  $\mathbf{q}$ .

Answer  $-\frac{2}{3}\mathbf{p} - \mathbf{q}$  [1]

(c) If the length of each small square is 1 unit, calculate  $|\overrightarrow{OS}|$ .

$$\begin{aligned} |\overrightarrow{OS}| &= \sqrt{2^2 + 5^2} \\ &= 5.3851 \\ &= 5.39 \text{ unit} \end{aligned}$$

Answer 5.39 unit [2]

- 17 (a) Calculate the size of an exterior angle of a regular polygon with 12 sides.

$$1 \text{ exterior angle} = \frac{360}{12} = 30^\circ$$

Answer 30° [1]

- (b) Tile  $P$  is in the shape of a regular 12-sided polygon.  
Explain, showing your working clearly, whether tiles  $P$  will fit together on the floor without gaps.

Answer

$$1 \text{ interior angle} = 180 - 30 = 150^\circ$$

$$\frac{360}{150} = 2.4 \text{ which is not a positive integer so the tiles will not fit}$$

together on the floor without gaps. [2]

- 18 On a map, a straight road measuring 600 m is represented by a line segment of length 7.5 cm.

- (a) Express the scale of the map in the ratio  $1 : r$ .

$$\begin{array}{l} 7.5 \text{ cm} : 60\,000 \text{ cm} \\ 1 : 8000 \end{array}$$

Answer 1 : 8000 [1]

- (b) The length of a canal on the map is 25 cm. Find the actual length in km.

$$\begin{array}{l} 1 \text{ cm} : 8000 \text{ cm} \\ 25 \text{ cm} : 200\,000 \text{ cm} \end{array}$$

Answer 2 km [1]

- (c) The actual area of a school is  $22\,400 \text{ m}^2$ . Find the area of the school on the map.

$$\begin{array}{l} 80 \text{ m} : 1 \text{ cm} \\ 6400 \text{ m}^2 : 1 \text{ cm}^2 \\ 22\,400 \text{ m}^2 : 22400/6400 = 3.5 \text{ cm}^2 \end{array}$$

Answer 3.5  $\text{cm}^2$  [2]

- 19  $ABC$  is a triangle in which  $AC = 13$  cm,  $BC = 11$  cm and  $AB = 20$  cm.  $P$  is a point on  $BC$  produced, where  $CP = 5$  cm and  $AP = 12$  cm.

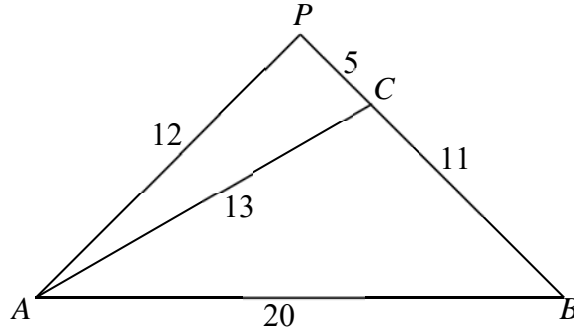

- (a) Explain why  $\angle APB = 90^\circ$ .

Answer

$$\begin{aligned} AP^2 + PC^2 &= 12^2 + 5^2 \\ &= 13^2 \end{aligned}$$

$$\therefore AP^2 + PC^2 = AC^2$$

By converse of Pythagoras' Theorem,  $\triangle APC$  is a right-angled  $\triangle$ . So  $\angle APB = 90^\circ$

[2]

- (b) Expressing your answer as a fraction in its simplest form, find

$$\frac{\tan \angle ABC}{\cos \angle ACB}$$

$$\frac{\tan \angle ABC}{\cos \angle ACB}$$

$$= \frac{12/16}{-5/13}$$

$$= -\frac{39}{20}$$

B2

A1

$$\text{Answer } \underline{-\frac{39}{20}} \quad [3]$$

- 20** The graph shows the number of accidents occurring at a road junction over a number of years.  
State one aspect of the graph that may be misleading and explain how this may lead to a misinterpretation of the graph.

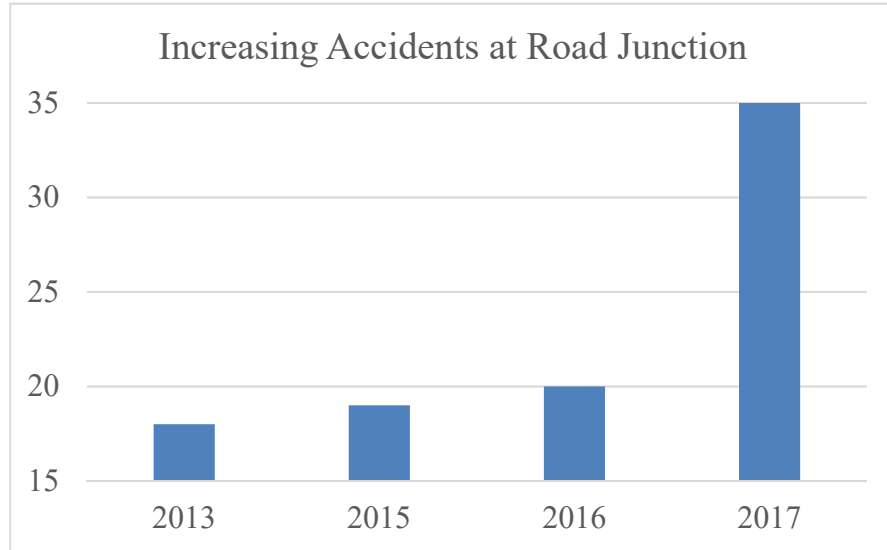

*Answer*

Title is biased and misleading. It does not allow the reader to form their own opinion. [2]

The year 2014 is left out. The number of accidents may be higher or lower.

The vertical axis did not start from 0, giving an exaggerated difference between the bars.

For  
Examiner's  
Use

For  
Examiner's  
Use

- 21 The diagram shows the speed-time graph of a lorry. The lorry starts from rest and accelerates uniformly to a speed of 15m/s in 10 seconds. The lorry then travels at a constant speed for some time before it decelerates uniformly at  $0.75 \text{ m/s}^2$  until it comes to rest. The whole journey takes one minute.

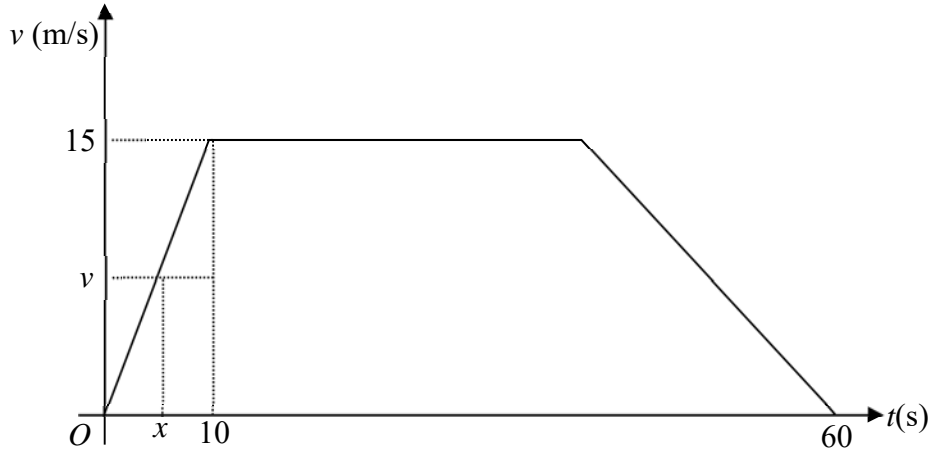

- (a) Given that the speed after  $x$  seconds is  $v$  m/s, express  $v$  in terms of  $x$ .

$$\frac{v}{x} = \frac{15}{10}$$

$$v = 1.5x$$

Answer  $v = \underline{\quad 1.5x \quad}$  [1]

- (b) For how long does the lorry travel at the maximum speed ?

$$\frac{15-0}{x-60} = -\frac{3}{4}$$

$$60 = 3x + 180$$

$$3x = 120$$

$$x = 40$$

It travels for  $40 - 10 = 30$  s

Answer  $\underline{\quad 30 \quad}$  s [2]

- (c) Calculate the total distance travelled by the lorry during this 1 minute journey.

$$\text{Total distance} = \frac{1}{2}(30+60)15 \quad \text{M1}$$

$$= 675 \text{ m} \quad \text{A1}$$

Answer  $\underline{\quad 675 \quad}$  m [2]

**End of Paper**



CEDAR GIRLS' SECONDARY SCHOOL  
Preliminary Examination  
Secondary Four

---

**MATHEMATICS**

Paper 2

**4048/02**

16 August 2018

**2 hours 30 minutes**

Additional Materials: Answer Paper (10 sheets)  
Graph paper (1 sheet)

---

**READ THESE INSTRUCTIONS FIRST**

Write your Centre number, index number and name on all the work you hand in.

Write in dark blue or black pen on both sides of the paper.

You may use a pencil for any diagrams or graphs.

Do not use staples, paper clips, highlighters, glue or correction tape.

Answer **all** questions.

If working is needed for any question it must be shown with the answer.

Omission of essential working will result in loss of marks.

Calculators should be used where appropriate.

If the degree of accuracy is not specified in the question, and if the answer is not exact, give the answer to three significant figures. Give answers in degrees to one decimal place.

For  $\pi$ , use either your calculator value or 3.142, unless the question requires the answer in terms of  $\pi$ .

At the end of the examination, fasten all your work securely together.

The number of marks is given in brackets [ ] at the end of each question or part question.

The total number of marks for this paper is 100.

## ***Mathematical Formulae***

### *Compound interest*

$$\text{Total amount} = P \left( 1 + \frac{r}{100} \right)^n$$

### *Mensuration*

$$\text{Curved surface area of a cone} = \pi r l$$

$$\text{Surface area of a sphere} = 4\pi r^2$$

$$\text{Volume of a cone} = \frac{1}{3} \pi r^2 h$$

$$\text{Volume of a sphere} = \frac{4}{3} \pi r^3$$

$$\text{Area of triangle } ABC = \frac{1}{2} ab \sin C$$

$$\text{Arc length} = r\theta, \text{ where } \theta \text{ is in radians}$$

$$\text{Sector area} = \frac{1}{2} r^2 \theta, \text{ where } \theta \text{ is in radians}$$

### *Trigonometry*

$$\frac{a}{\sin A} = \frac{b}{\sin B} = \frac{c}{\sin C}$$

$$a^2 = b^2 + c^2 - 2bc \cos A$$

### *Statistics*

$$\text{Mean} = \frac{\sum fx}{\sum f}$$

$$\text{Standard deviation} = \sqrt{\frac{\sum fx^2}{\sum f} - \left( \frac{\sum fx}{\sum f} \right)^2}$$

Answer **all** the questions.

- 1 (a) Simplify  $\frac{24c^3d^2}{(3de^2)^3} \div \frac{5c^{-2}}{10df}$ . [2]
- (b) Express as a single fraction  $\frac{7}{(6-5p)^2} - \frac{2p-1}{10p-12}$ . [3]
- (c) Simplify  $\frac{6x^2-17x+5}{18x^2-2} \times \frac{15x+5}{10-4x}$ . [3]
- (d) It is given that  $1 - \frac{a-b}{b+2c} = \frac{2a-1}{2}$ .  
Express  $b$  in terms of  $a$  and  $c$ . [3]
- 

- 2 The diagram shows a solid prism  $ABCDEFGH$  with a horizontal rectangular base  $EFGH$  and a horizontal rectangular top  $ABCD$ .  
 $B$  is vertically above  $F$  and  $A$  is vertically above  $E$ .  
 $BC = 20$  cm,  $FG = 36$  cm,  $BF = 12$  cm and  $GH = 40$  cm.

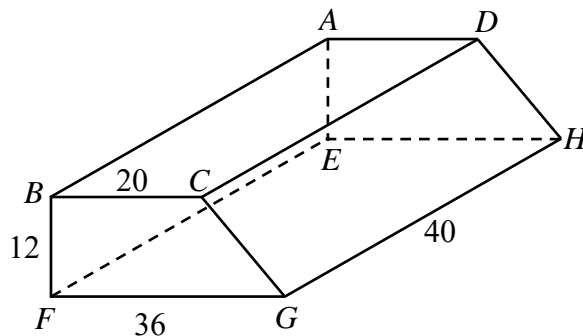

- (a) Find the length of  $BH$ . [2]
- (b) Find the **total surface area** of the prism. [3]
- (c) The prism is melted and recast into a right pyramid with a square base.  
The height of the pyramid is 24 cm.  
Find the length of each side of the square base. [3]
-

**3 Answer the whole of this question on a single sheet of graph paper.**

A bakery makes a profit of  $y$  thousand dollars for selling  $x$  thousand pieces of blueberry tarts.

The variables  $x$  and  $y$  are connected by the equation

$$y = 5x - x^2 - 2.$$

Some corresponding values of  $x$  and  $y$  are given in the table below.

$x$	0	0.5	1	1.5	2	3	4
$y$	-2	0.25	2	3.25	4	4	2

- (a) Using a scale of 4 cm to represent 1 unit, draw a horizontal  $x$ -axis for  $0 \leq x < 4$ .  
Using a scale of 2 cm to represent 1 unit, draw a vertical  $y$ -axis for  $-3 \leq y \leq 5$ .

On your axes, plot the points given in the table and join them with a smooth curve. [3]

- (b) Use your graph to find

(i) the maximum profit obtained from selling the blueberry tarts, [1]

(ii) the minimum number of blueberry tarts the bakery must sell in order to cover the costs of baking the tarts, [1]

(iii) the range of values of  $x$  for which the profit is more than \$2750. [1]

- (c) (i) On the same axes, draw the graph of  $\frac{y}{x} = \frac{1}{4}$ . [1]

(ii) Write down the  $x$ -coordinate of the point where the two graphs intersect. [1]

(iii) State briefly what the value of this  $x$ -coordinate represents. [1]

(iv) The value of  $x$  in (c)(ii) is the solution of the equation  $4x + \frac{A}{x} + B = 0$ .  
Find each of the value of integers  $A$  and  $B$ . [2]

4

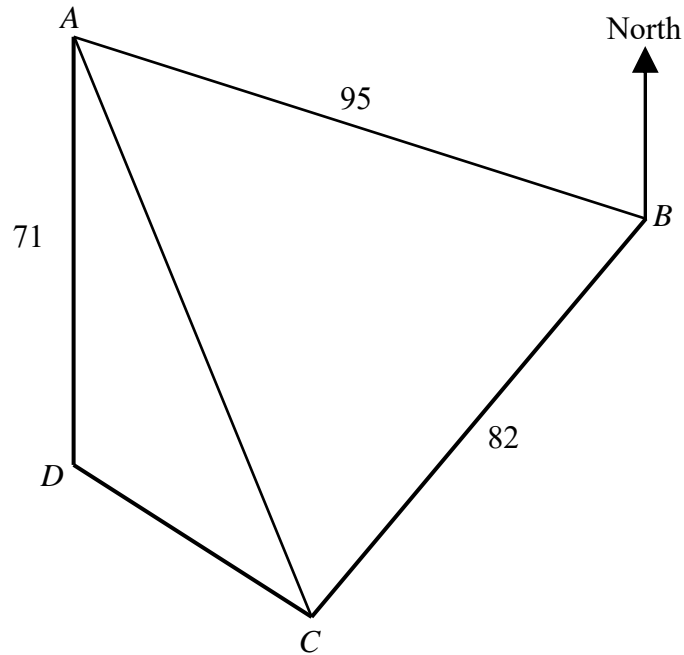

Quadrilateral  $ABCD$  is a field on horizontal ground.  
 $A$  is 95 m from  $B$  on a bearing of  $280^\circ$ .  
 $B$  is 82 m from  $C$  on a bearing of  $025^\circ$ .  
 $D$  is due south and 71 m from  $A$ .

Calculate

- (a) area of triangle  $ABC$ , [2]  
 (b)  $AC$ , [2]  
 (c) angle  $ACB$ . [2]

A vertical tower of 67 m stands at  $D$ .

A man walked along  $AC$ .

He stopped at  $E$  to take a picture of the tower where the angle of elevation of the top of the tower was the greatest.

- (d) Calculate the angle of elevation of the top of the tower at  $E$ . [3]

- 5 A route up a mountain is 25 km long.  
Hwee Ling walked along this route up the mountain at an average speed of  $x$  km/h.

- (a) Write down an expression, in terms of  $x$ , the number of hours she took to walk up the mountain. [1]

She walked down the mountain by a different route.

The length of this route is 30 km long.

Her average speed walking down the mountain was 3 km/h greater than her average speed walking up the mountain.

- (b) Write down an expression, in terms of  $x$ , the number of hours she took to walk down the mountain. [1]

- (c) It took Hwee Ling  $1\frac{1}{4}$  hours less to walk down the mountain than to walk up the mountain.

Write down an equation to represent this information and show that it simplifies to

$$x^2 + 7x - 60 = 0. \quad [3]$$

- (d) Solve the equation  $x^2 + 7x - 60 = 0$ . [2]

- (e) Find the time Hwee Ling took to walk down the mountain. [1]
-

- 6 In a Mathematics examination, 500 students each took two papers. Both papers were marked out of 50. The cumulative frequency curves show the distribution of the marks for the two papers.

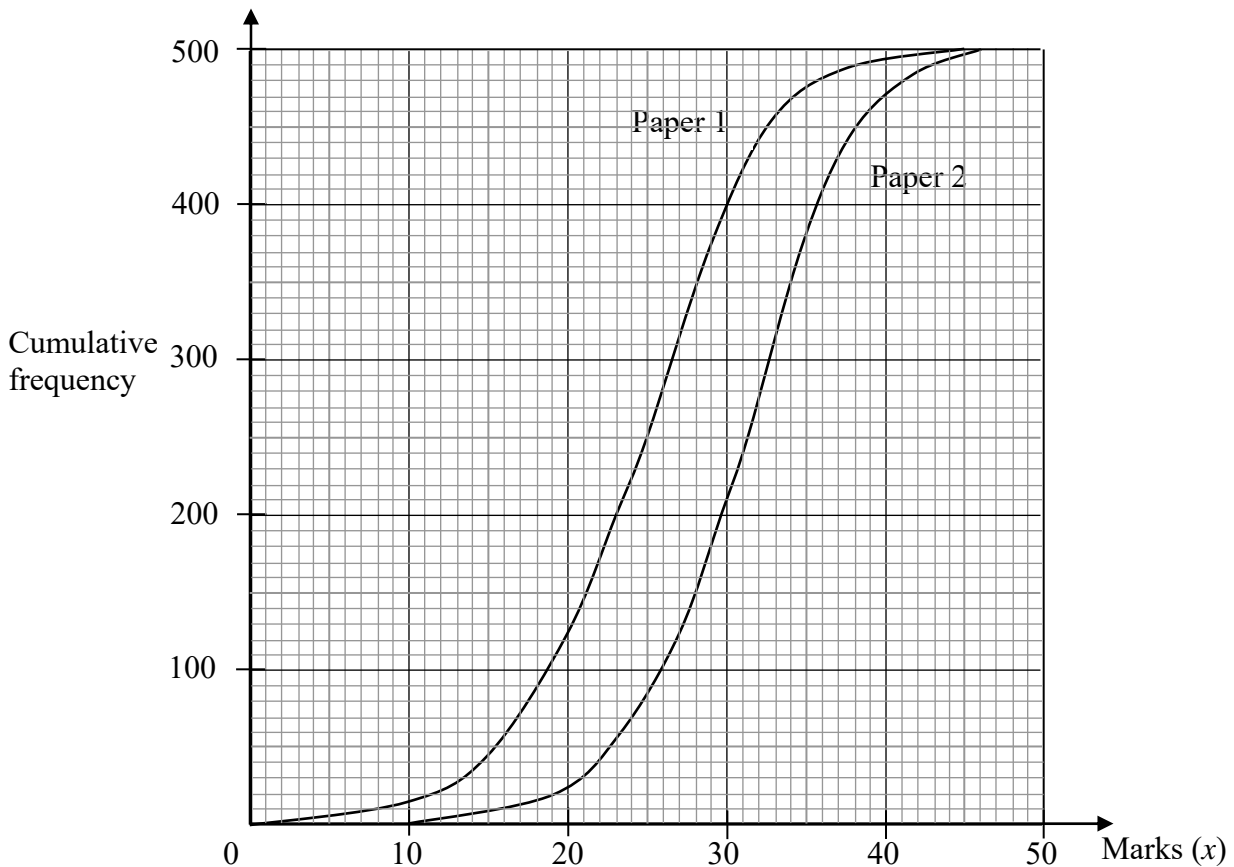

- (a) For **Paper 1**, estimate the interquartile range. [2]
- (b) The grouped frequency table of the marks obtained by the students for **Paper 2** is shown below.

Marks ( $x$ )	$10 \leq x < 19$	$19 \leq x < 28$	$28 \leq x < 37$	$37 \leq x < 46$
Frequency	$p$	$q$	$r$	$s$

- (i) Find each of the values of  $p$ ,  $q$ ,  $r$  and  $s$ . [2]
- (ii) Calculate an estimate of the mean mark obtained for Paper 2. [2]
- (iii) Calculate an estimate of the standard deviation for Paper 2. [2]
- (c) An additional student obtained 28 marks in Paper 1, but was absent for Paper 2. Estimate the mark she would have obtained if she had taken Paper 2. [1]
- (d) Which was the more difficult paper? Justify your answer. [2]

- 7 (a) The first four terms in a sequence of numbers,  $T_1, T_2, T_3$ , are given below.

$$T_1 = 3^0 - 2 = -1$$

$$T_2 = 3^1 - 5 = -2$$

$$T_3 = 3^2 - 8 = 1$$

$$T_4 = 3^3 - 11 = 16$$

- (i) Write down an expression for  $T_5$ . [1]
- (ii) Find an expression, in terms of  $n$ , for  $T_n$ . [3]
- (iii) Evaluate  $T_{15}$ . [1]
- (b) The table shows the numbers of English and Chinese copies of a book sold on a typical weekday and a weekend.

	English	Chinese
Weekday	6	8
Weekend	12	14

The cost price of an English copy and a Chinese copy of the book is \$12 and \$15 respectively.

The selling price of an English copy and a Chinese copy of the book is \$ $p$  and \$ $q$  respectively.

All the information can be represented by the matrices

$$\mathbf{A} = \begin{pmatrix} 6 & 8 \\ 12 & 14 \end{pmatrix}, \quad \mathbf{P} = \begin{pmatrix} 12 \\ 15 \end{pmatrix}, \quad \mathbf{S} = \begin{pmatrix} p \\ q \end{pmatrix}.$$

- (i) Let  $\mathbf{B} = \mathbf{S} - \mathbf{P}$ .  
Evaluate  $\mathbf{C} = \mathbf{AB}$ . [2]
- (ii) The total profits gained from selling the English and Chinese copies of the book on a typical weekday and a weekend are \$92 and \$170 respectively.  
Write down a  $2 \times 1$  matrix  $\mathbf{D}$  to represent the information and hence find the value of  $p$  and of  $q$ . [4]

- 8 (a) In the diagram,  $A$ ,  $B$  and  $C$  lie on a circle, centre  $O$ .  
The tangents at  $A$  and  $C$  meet at  $T$ .  
Angle  $COA = 116^\circ$ .

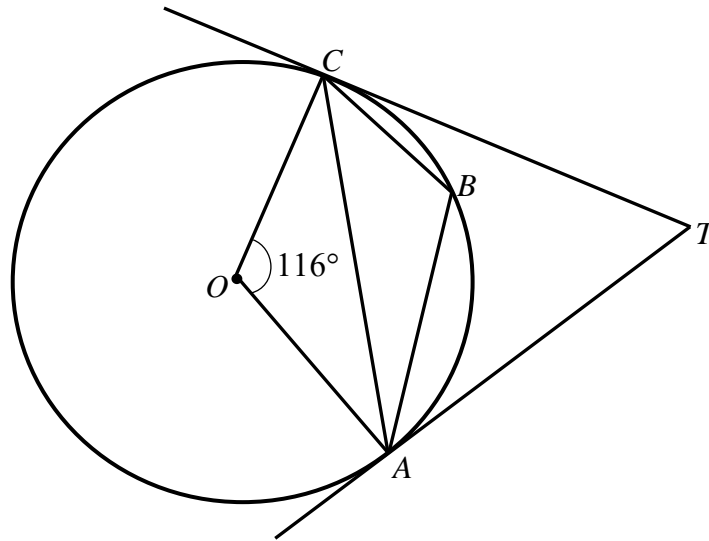

Find, stating your reasons clearly,

- (i) obtuse angle  $ABC$ , [1]
- (ii) angle  $CAT$ , [1]
- (iii) angle  $CTA$ . [1]
- (b) The figure shows a semicircle  $PQS$  with centre  $O$  with diameter  $PQ$  and a semicircle  $PRT$  with diameter  $PR$ .

$PQ = 10$  cm and angle  $RPO = \frac{\pi}{5}$  radians.

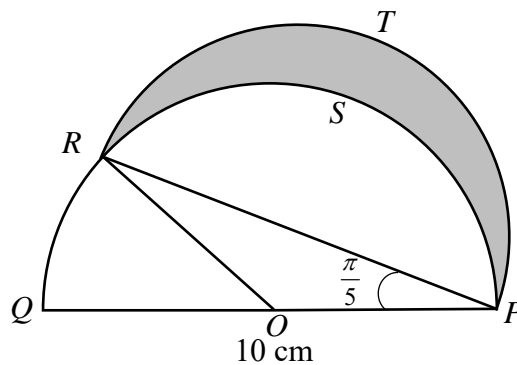

- (i) Show that  $PR = 8.0902$  cm, correct to 5 significant figures. [2]
- (ii) Find the perimeter of the shaded region. [3]
- (iii) Find the area of the shaded region. [3]

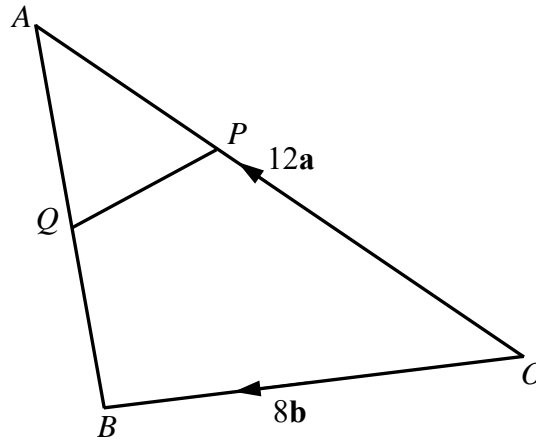

The position vectors of  $A$  and  $B$ , relative to  $O$ , are  $12\mathbf{a}$  and  $8\mathbf{b}$  respectively.  
 $\overrightarrow{OP} = 2\overrightarrow{PA}$  and  $\overrightarrow{AQ} = \overrightarrow{QB}$ .

- (a) Express each of the following in terms of  $\mathbf{a}$  and  $\mathbf{b}$
- (i)  $\overrightarrow{AQ}$ , [1]
- (ii)  $\overrightarrow{BP}$ , [1]
- (iii)  $\overrightarrow{QP}$ . [1]
- (b) Find the position vector of  $R$  such that  $\overrightarrow{PR} = 4\overrightarrow{PQ}$ . [1]
- (c) Make two statements about the points  $O$ ,  $B$  and  $R$ . [2]
- (d) Find the position vector of  $S$  such that  $PQBS$  is a parallelogram. [1]
- (e) Find  $\frac{\text{Area of } \triangle OBP}{\text{Area of } \triangle ORA}$ . [1]
- (f) Given that  $\mathbf{a} = \begin{pmatrix} -1 \\ 1 \end{pmatrix}$  and  $\mathbf{b} = \begin{pmatrix} -1 \\ -1 \end{pmatrix}$ , find  $|\overrightarrow{AB}|$ . [2]

**10** The electricity tariff is the cost of electricity per kilowatt hour (kWh) and is revised every quarter of the year to reflect the actual cost of electricity.

- (a) In June 2018, Mr Lim paid \$148.13, inclusive of 7% GST, for an electricity consumption of 625 kWh in his household.

Calculate the electricity tariff in June 2018.

[2]

From July 2018, Mr Lim decided to purchase electricity from a new supplier for a duration of 12 months.

Below are the available plans.

Company	Type of Plan	Details of Plan
Best Power	Fixed rate	<ul style="list-style-type: none"> <li>1 year contract</li> <li>\$0.1667/kWh</li> </ul>
Marco Energy	Fixed rate	<ul style="list-style-type: none"> <li>1 year contract</li> <li>\$10 per month + \$0.1535/kWh</li> </ul>
Infinity Power	Fixed rate	<ul style="list-style-type: none"> <li>6 months contract (one time 5% discount for renewal of another 6 months)</li> <li>\$0.1730/kWh (for first 6 months)</li> </ul>
Rainbow Energy	Discount off tariff *	<ul style="list-style-type: none"> <li>1 year contract</li> <li>20% off tariff</li> </ul>
Unicorn Supply	Peak and off-peak	<ul style="list-style-type: none"> <li>Peak: \$0.1685/kWh (7am to 10.59pm)</li> <li>Off-peak: \$0.1438/kWh (11pm to 6.59am)</li> </ul>

\* Based on the prevailing electricity tariff for that quarter

The consumption trend for Mr Lim's household and the projected quarterly household electricity tariffs for the next 12 months are on the next page.

The electricity consumption of his household during peak hours is estimated to be 3 times that during off-peak hours.

- (b) Find the average monthly electricity consumption of Mr Lim's household from January 2018 to June 2018.

[1]

- (c) Determine which electricity supplier should Mr Lim choose.

Justify your answer with relevant working and state an assumption made.

[7]

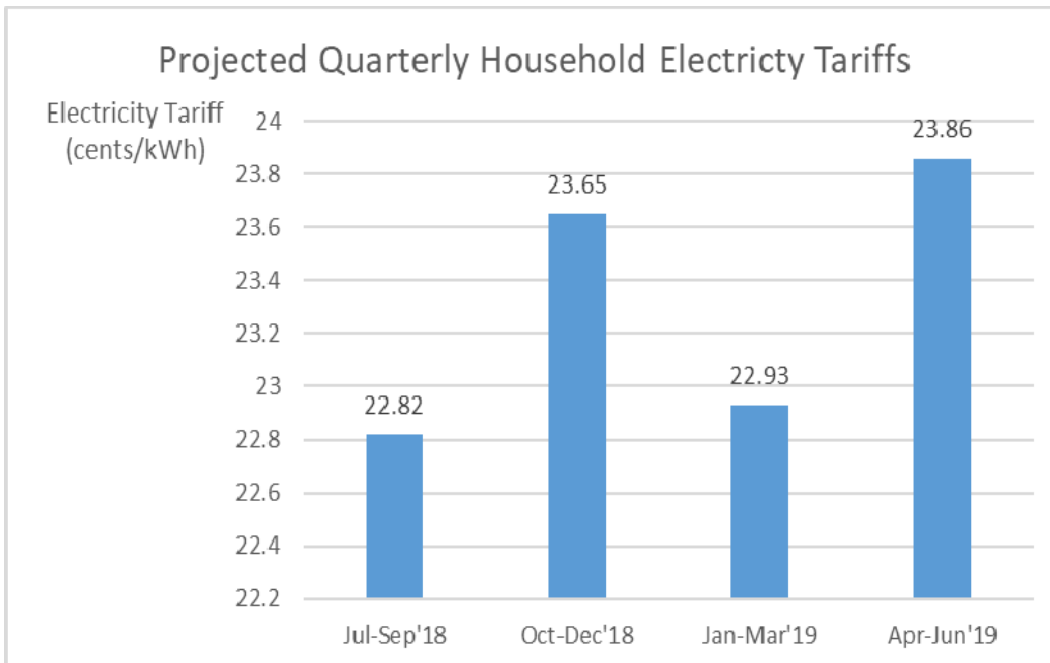
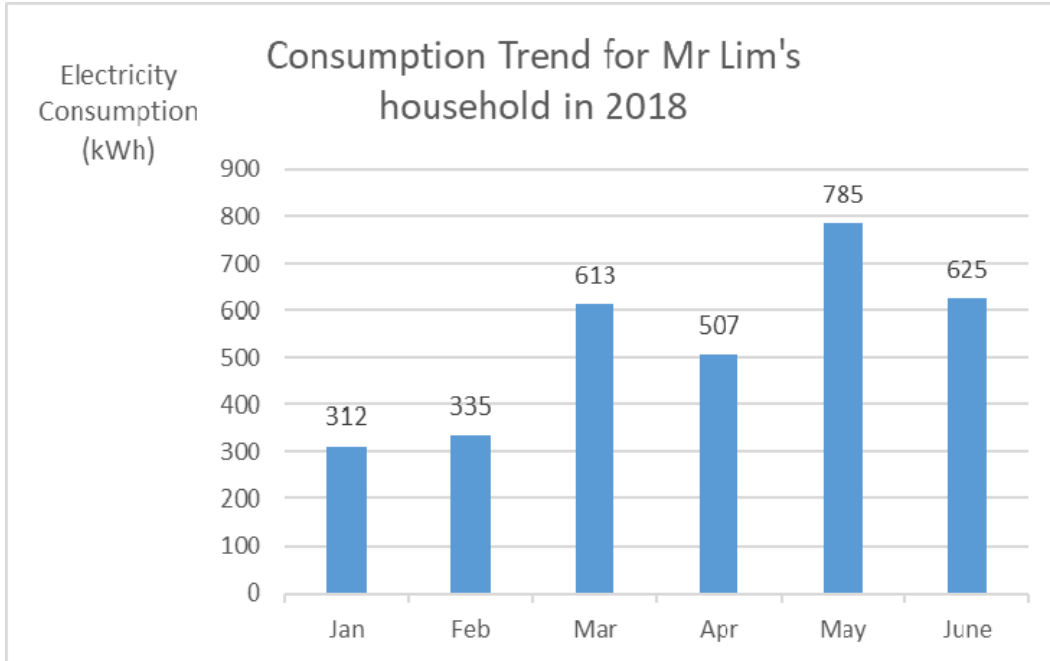

**End of Paper**

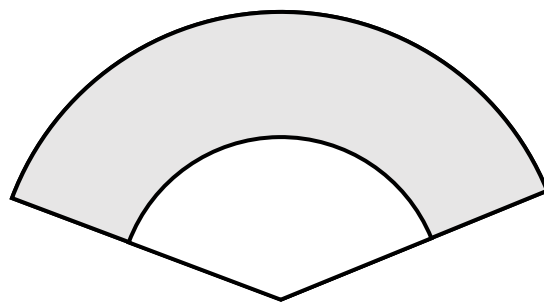



# CEDAR GIRLS' SECONDARY SCHOOL

## SECONDARY 4 MATHEMATICS

### Answer Key for 2018 Preliminary Examination

PAPER 4048/2			
<b>1(a)</b>	$\frac{16c^5 f}{9e^6}$	<b>6(a)</b>	9 marks
		<b>6(bi)</b>	$p = 20, q = 130, r = 280, s = 70$
<b>1(b)</b>	$\frac{-10p^2 + 17p + 8}{2(6 - 5p)^2}$	<b>6(bii)</b>	30.7 marks
		<b>6(biii)</b>	6.49 marks (3 s.f)
<b>1(c)</b>	$-\frac{5}{4}$	<b>6(c)</b>	34 marks
<b>1(d)</b>	$b = \frac{4ac - 6c + 2a}{5 - 2a}$	<b>6(d)</b>	Paper 1 The median mark for Paper 1 is lower than the median mark for Paper 2.
<b>2(a)</b>	55.1 cm (3 s.f)	<b>7(ai)</b>	$T_5 = 3^4 - 14 = 67$
<b>2(b)</b>	4192 cm <sup>2</sup>	<b>7(aii)</b>	$T_n = 3^{n-1} - 3n + 1$
<b>2(c)</b>	41.0 cm	<b>7(aiii)</b>	4 782 925
<b>3(bi)</b>	\$4250 (accept \$4200 to \$4300)	<b>7(b)(i)</b>	$C = \begin{pmatrix} 6p + 8q - 192 \\ 12p + 14q - 354 \end{pmatrix}$
<b>3(bii)</b>	425 tarts (accept 400 to 450)	<b>7(b)(ii)</b>	$q = 22, p = 18$
<b>3(biii)</b>	1.28 ≤ x ≤ 3.72 (accept lower limit: 1.25 to 1.35 (accept upper limit: 3.65 to 3.75)	<b>8 (ai)</b>	122°
		<b>8(bii)</b>	22.1 cm (3 s.f)
		<b>9(ai)</b>	4b - 6a
		<b>9(aiii)</b>	2a - 4b
<b>3(cii)</b>	0.45 ± 0.05	<b>9(b)</b>	$\overline{OR} = 16b$
		<b>9(c)</b>	O, B and R are collinear. $OR = 2OB$ or B is the midpoint of OR.
		<b>9(d)</b>	$\overline{OS} = 2a + 4b$
<b>3(ciii)</b>	The number of thousand pieces of blueberry tarts to be sold such that the profit made per piece is \$0.25.	<b>9(e)</b>	$\frac{1}{3}$
		<b>9(f)</b>	20.4 units (3 sf)
<b>3(civ)</b>	A = 8, B = -19	<b>10(a)</b>	\$0.2215 / kWh
		<b>10(b)</b>	529.5 kWh
<b>4(a)</b>	3760 cm <sup>2</sup> (3 s.f)	<b>10(c)</b>	<u>Best Power (all for 12 months)</u> Total cost = 12 × 529.5 × 0.1667 = \$1059.21 <u>Marco Energy</u> Total cost = 12(10 + 0.1535 × 529.5) = \$1095.34 <u>Infinity Power</u> Total cost = (6 × 529.5 × 0.1730) + (6 × 0.95 × 0.1730 × 529.5) = \$1071.76 <u>Rainbow Energy</u> Total cost = 3 × 0.8 × 529.5(0.2282 + 0.2365 + 0.2293 + 0.2386) = \$1185.15 <u>Unicorn Supply</u> Total cost = 12 × (0.75 × 529.5 × 0.1685 + 0.25 × 529.5 × 0.1438) = \$1031.41 Mr Lim should choose Unicorn Supply as it has the lowest total costs for the next 12 months. The electricity consumption in Mr Lim's household is consistent throughout the year OR The projected quarterly household electricity tariffs are fairly accurate.
<b>4(b)</b>	108 m (3 s.f)		
<b>4(c)</b>	58.0°		
<b>4(d)</b>	60.0° (1 dp)		
<b>5(a)</b>	$\left(\frac{25}{x}\right) h$		
<b>5(b)</b>	$\left(\frac{30}{x+3}\right) h$		
<b>5(d)</b>	x = -12 or x = 5		
<b>5(e)</b>	3.75 h		

**2018 Sec 4 Prelim**  
**Mathematics 4048 P2**  
**Solutions**

Qn	Working
1a	$\frac{24c^3d^2}{(3de^2)^3} \div \frac{5c^{-2}}{10df}$ $= \frac{24c^3d^2}{27d^3e^6} \times \frac{10df}{5c^{-2}}$ $= \frac{16c^5f}{9e^6}$
1b	$\frac{7}{(6-5p)^2} - \frac{2p-1}{10p-12}$ $= \frac{7}{(6-5p)^2} + \frac{2p-1}{2(6-5p)}$ $= \frac{14 + (2p-1)(6-5p)}{2(6-5p)^2}$ $= \frac{14 + (2p-1)(6-5p)}{2(6-5p)^2}$ $= \frac{14 + 12p - 10p^2 - 6 + 5p}{2(6-5p)^2}$ $= \frac{-10p^2 + 17p + 8}{2(6-5p)^2}$
1c	$\frac{6x^2 - 17x + 15}{18x^2 - 2} \times \frac{15x + 5}{10 - 4x}$ $= \frac{(3x-1)(2x-5)}{2(3x-1)(3x+1)} \times \frac{5(3x+1)}{-2(2x-5)}$ $= -\frac{5}{4}$
1d	$1 - \frac{a-b}{b+2c} = \frac{2a-1}{2}$ $\frac{b+2c-a+b}{b+2c} = \frac{2a-1}{2}$ $\frac{2b+2c-a}{b+2c} = \frac{2a-1}{2}$ $4b+4c-2a = 2ab+4ac-b-2c$ $5b-2ab = 4ac-6c+2a$ $b(5-2a) = 4ac-6c+2a$ $b = \frac{4ac-6c+2a}{5-2a}$

Qn	Working
<b>2a</b>	$FH^2 = 36^2 + 40^2$ $FH = \sqrt{2896} \text{ or } 53.814 \text{ cm}$ $BH = \sqrt{12^2 + 2896}$ $BH = 55.1 \text{ cm (3 s.f)}$
<b>2b</b>	$CG = \sqrt{12^2 + 16^2} = 20 \text{ cm}$ <p>Perimeter of the cross-sectional area = <math>20 + 12 + 36 + 20 = 88 \text{ cm}</math></p> <p>Lateral surface area = <math>88 \times 40 = 3520 \text{ cm}^2</math></p> <p>Total Surface area</p> $= 3520 + 2 \left( \frac{1}{2} \times (20 + 36) \times 12 \right)$ $= 4192 \text{ cm}^2$
<b>2c</b>	<p>Volume of prism</p> $= 336 \times 40 \text{ m}^3$ $= 13440 \text{ m}^3$ <p>Let the side of the square base be <math>x</math>.</p> $\frac{1}{3} \times x^2 \times 24 = 13440$ $x = 41.0 \text{ cm (3 s.f)}$

Qn	Working
<b>3(a)</b>	Correct plotting of points Correct scale and axes Smoothness of curve
<b>(b)(i)</b>	\$4250 (accept \$4200 to \$4300)
<b>(b)(ii)</b>	425 tarts (accept 400 to 450)
<b>(b)(iii)</b>	$1.275 < x < 3.675$ (accept lower limit: 1.25 to 1.35 (accept upper limit: 3.65 to 3.75)
<b>(c)(i)</b>	Draw line $\frac{y}{x} = \frac{1}{4}$
<b>(c)(ii)</b>	0.45 (accept 0.4 to 0.5)
<b>(c)(iii)</b>	The number of pieces of the blueberry tarts to be sold such that the profit made per piece is \$0.25.
<b>(c)(iv)</b>	$5x - x^2 - 2 = \frac{1}{4}x$ $x^2 - 4\frac{3}{4}x + 2 = 0$ $4x^2 - 19x + 8 = 0$ $4x - 19 + \frac{8}{x} = 0$ $A = 8, B = -19$

Qn	Working
4a	Area of triangle $ABC$ $= \frac{1}{2}(95)(82) \sin 75^\circ$ $= 3760 \text{ cm}^2 (3 \text{ s.f.})$
4b	$AC^2 = 95^2 + 82^2 - 2(95)(82) \cos 75^\circ$ $AC = 108.24$ $= 108 \text{ m} (3 \text{ s.f.})$
4c	$\frac{\sin \angle ACB}{95} = \frac{\sin 75^\circ}{108.24}$ $\angle ACB = 57.970^\circ$ $= 58.0^\circ$
4d	$\angle DAC = 57.970^\circ - 25^\circ$ $= 32.97^\circ \text{ (alt } \angle\text{s, parallel lines)}$ $\sin 32.97^\circ = \frac{DE}{71}$ $DE = 38.638 \text{ m}$ <p>Let the greatest angle of elevation be <math>\theta</math>.</p> $\tan \theta = \frac{67}{38.638}$ $\theta = 60.0^\circ (1 \text{ dp})$

Qn	Working
5a	$\left(\frac{25}{x}\right) h$
5b	$\left(\frac{30}{x+3}\right) h$
5c	$\frac{25}{x} - \frac{30}{x+3} = \frac{5}{4}$ $\frac{25(x+3) - 30x}{x(x+3)} = \frac{5}{4}$ $\frac{75 - 5x}{x(x+3)} = \frac{5}{4}$ $300 - 20x = 5x^2 + 15x$ $5x^2 + 35x - 300 = 0$ $x^2 + 7x - 60 = 0 \text{ (shown)}$
5d	$x^2 + 7x - 60 = 0$ $(x+12)(x-5) = 0$ $x = -12 \text{ or } x = 5$
5e	$\frac{30}{5+3} = 3.75 \text{ h}$

Qn	Working
<b>6a</b>	Interquartile range = $29 - 20 = 9$ marks
<b>6bi</b>	$p = 20, q = 130, r = 280, s = 70$
<b>6bii</b>	Mean = $\frac{15350}{500}$ = 30.7 marks
<b>6biii</b>	SD = $\sqrt{\frac{492305}{500} - \left(\frac{15350}{500}\right)^2}$ = 6.49 marks (3 s.f)
<b>6c</b>	34 marks
<b>6d</b>	Median mark for Paper 1 = 25 Median mark for Paper 2 = 31.5 (between 31 and 32) Since the median mark for Paper 1 is lower than the median mark for Paper 2, Paper 1 is the more difficult paper.

Qn	Working
7ai	$T_5 = 3^4 - 14 = 67$
7aii	$T_n = 3^{n-1} - (2 + 3(n-1))$ $= 3^{n-1} - (3n-1)$ $= 3^{n-1} - 3n + 1$
7aiii	$T_{15} = 3^{14} - 3(15) + 1 = 4\,782\,925$
7bi	$\mathbf{B} = \begin{pmatrix} p-12 \\ q-15 \end{pmatrix}$ $\mathbf{C} = \begin{pmatrix} 6 & 8 \\ 12 & 14 \end{pmatrix} \begin{pmatrix} p-12 \\ q-15 \end{pmatrix}$ $= \begin{pmatrix} 6p-72+8q-120 \\ 12p-144+14q-210 \end{pmatrix}$ $= \begin{pmatrix} 6p+8q-192 \\ 12p+14q-354 \end{pmatrix}$
7bii	$\mathbf{D} = \begin{pmatrix} 92 \\ 170 \end{pmatrix}$ $\begin{pmatrix} 6p+8q-192 \\ 12p+14q-354 \end{pmatrix} = \begin{pmatrix} 92 \\ 170 \end{pmatrix}$ $6p+8q-192 = 92$ $6p+8q = 284 \text{ -----(1)}$ $12p+14q-354 = 170$ $12p+14q = 524 \text{ -----(2)}$ $(1) \times 2 : 12p+16q = 568 \text{ -----(3)}$ $(3) - (2) : 2q = 44$ $q = 22, p = 18$

Qn	Working
8ai	Reflex angle $COA = 360^\circ - 116^\circ$ $= 244^\circ$ Angle $CBA = \frac{244^\circ}{2}$ $= 122^\circ$ ( $\angle$ at centre = $2\angle$ at circumference)
8aii	Angle $OAC = \frac{180^\circ - 116^\circ}{2}$ (base $\angle$ s of isos. $\Delta$ ) $= 32^\circ$ Angle $CAT = 90^\circ - 32^\circ$ (tan $\perp$ rad) $= 58^\circ$
8aiii	Angle $ACT = \text{angle } CAT = 58^\circ$ (tangents from ext. pt) Angle $CTA = 180^\circ - 2(58^\circ)$ ( $\angle$ sum of $\Delta$ ) $= 64^\circ$
8bi	Triangle $QRP$ is a right angle triangle ( $\angle$ in semicircle) $\cos \frac{\pi}{5} = \frac{RP}{10}$ $RP = 10 \cos \left( \frac{\pi}{5} \right)$ $PR = 8.0902$ cm (to 5 s.f)  OR Angle $ROP = \pi - 2 \left( \frac{\pi}{5} \right) = \frac{3\pi}{5}$ (base $\angle$ s of isos $\Delta$ , $\angle$ sum of $\Delta$ ) $PR^2 = 5^2 + 5^2 - 2(5)(5) \cos \frac{3\pi}{5}$ $PR = 8.0902$ cm (to 5 s.f)
8bii	Arc length $QR = 5 \left( \frac{2\pi}{5} \right) = 2\pi$ Arc length $RSP = 5\pi - 2\pi = 3\pi$ Semicircle $PRT = \frac{8.0902}{2} \pi = 4.0451\pi$ Perimeter of shaded region = $3\pi + 4.0451\pi$ $= 22.1$ cm (3 s.f)

<b>8biii</b>	$\text{Area of sector } ORSP = \frac{1}{2}(5)^2 \left( \frac{3\pi}{5} \right) = 7.5\pi \text{ cm}^2$ $\text{Area of triangle } ORP = \frac{1}{2}(5)(5) \sin \left( \frac{3\pi}{5} \right) = 11.888 \text{ cm}^2$ $\text{Area of segment } RSP = 7.5\pi - 11.888 = 11.674 \text{ cm}^2$ $\text{Area of shaded region} = \frac{1}{2}\pi \left( \frac{8.0902}{2} \right)^2 - 11.674 = 14.0 \text{ cm}^2 \text{ (to 3 sf)}$

Qn	Working
9ai	$\overline{AB} = \overline{OB} - \overline{OA}$ $= 8\mathbf{b} - 12\mathbf{a}$ $\overline{AQ} = 4\mathbf{b} - 6\mathbf{a}$
9aii	$\overline{BP} = \overline{BO} + \overline{OP}$ $= -8\mathbf{b} + 8\mathbf{a}$
9aiii	$\overline{QP} = \overline{QA} + \overline{AP}$ $= -4\mathbf{b} + 6\mathbf{a} - 4\mathbf{a}$ $= 2\mathbf{a} - 4\mathbf{b}$
9b	$\overline{PR} = 4\overline{PQ}$ $\overline{OR} - \overline{OP} = 4(4\mathbf{b} - 2\mathbf{a})$ $\overline{OR} - 8\mathbf{a} = 16\mathbf{b} - 8\mathbf{a}$ $\overline{OR} = 16\mathbf{b}$
9c	<p><math>OB</math> is parallel to <math>OR</math> and since <math>O</math> is a common point,  <math>O</math>, <math>B</math> and <math>R</math> are collinear.</p>
9d	<p><math>OR = 2OB</math> or <math>B</math> is the midpoint of <math>OR</math>.          Since <math>PQBS</math> is a parallelogram,  <math>\overline{QP} = \overline{BS}</math></p> $2\mathbf{a} - 4\mathbf{b} = \overline{OS} - 8\mathbf{b}$ $\overline{OS} = 2\mathbf{a} + 4\mathbf{b}$
9e	$\frac{\text{Area of } \triangle OBP}{\text{Area of } \triangle ORA} = \frac{\text{Area of } \triangle OBP}{\text{Area of } \triangle OBA} \times \frac{\text{Area of } \triangle OBA}{\text{Area of } \triangle ORA}$ $= \frac{2}{3} \times \frac{1}{2}$ $= \frac{1}{3}$
9f	$\overline{AB} = 8 \begin{pmatrix} -1 \\ -1 \end{pmatrix} - 12 \begin{pmatrix} -1 \\ 1 \end{pmatrix}$ $= \begin{pmatrix} 4 \\ -20 \end{pmatrix}$ $ \overline{AB}  = \sqrt{4^2 + (-20)^2}$ $= 20.4 \text{ units (3 sf)}$

Qn	Working
10a	$\text{Electricity tariff} = \frac{\frac{100}{107} \times 148.13}{625}$ $= \$0.2215 / \text{kWh}$
10b	Average consumption per month = 529.5 kWh
10c	<p><u>Best Power</u>  Total cost for 12 months = <math>12 \times 529.5 \times 0.1667</math>  = \$1059.21</p> <p><u>Marco Energy</u>  Total cost for 12 months = <math>12(10 + 0.1535 \times 529.5)</math>  = \$1095.34</p> <p><u>Infinity Power</u>  Total cost for 12 months = <math>(6 \times 529.5 \times 0.1730) + (6 \times 0.95 \times 0.1730 \times 529.5)</math>  = \$1071.76</p> <p><u>Rainbow Energy</u>  Total cost for 12 months = <math>3 \times 0.8 \times 529.5(0.2282 + 0.2365 + 0.2293 + 0.2386)</math>  = \$1185.15</p> <p><u>Unicorn Supply</u>  Total cost for 12 months = <math>12 \times (0.75 \times 529.5 \times 0.1685 + 0.25 \times 529.5 \times 0.1438)</math>  = \$1031.41</p> <p>Mr Lim should choose Unicorn Supply as it has the lowest total costs.</p> <p>Assumptions:  The electricity consumption in Mr Lim's household is consistent throughout the year OR  The projected quarterly household electricity tariff is fairly accurate.</p>