

Visit

FREETESTPAPER.com

for more papers



Website: freetestpaper.com



[Facebook.com/freetestpaper](https://www.facebook.com/freetestpaper)



[Twitter.com/freetestpaper](https://www.twitter.com/freetestpaper)

Name: _____

Register Number: _____

Class: _____

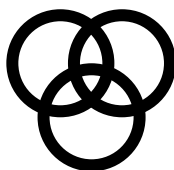

南僑中學

NAN CHIAU HIGH SCHOOL

PRELIMINARY EXAMINATION (2) 2018
SECONDARY FOUR EXPRESS

For Marker's Use

MATHEMATICS

4048/01

Paper 1

6 August 2018, Monday

2 hours

Candidates answer on the Question Paper

READ THESE INSTRUCTIONS FIRST

Write your name, class and index number on all the work you hand in.

Write in dark blue or black pen.

You may use a 2B pencil for any diagrams or graphs.

Do not use staples, paper clips, highlighters, glue or correction fluid.

Answer **all** questions.

If working is needed for any question it must be shown with the answer.

Omission of essential working will result in loss of marks.

The use of an approved calculator is expected, where appropriate.

If the degree of accuracy is not specified in the question, and if the answer is not exact, give the answer to three significant figures. Give answers in degrees to one decimal place.

For π , use either your calculator value or 3.142, unless the question requires the answer in terms of π .

The number of marks is given in brackets [] at the end of each question or part question.

The total marks for this paper is 80.

Setter: Ms Ting Shi Yun

Mathematical Formulae

Compound interest

$$\text{Total amount} = P \left(1 + \frac{r}{100} \right)^n$$

Mensuration

$$\text{Curved surface area of a cone} = \pi r l$$

$$\text{Surface area of a sphere} = 4\pi r^2$$

$$\text{Volume of a cone} = \frac{1}{3} \pi r^2 h$$

$$\text{Volume of a sphere} = \frac{4}{3} \pi r^3$$

$$\text{Area of triangle } ABC = \frac{1}{2} ab \sin C$$

$$\text{Arc length} = r\theta, \text{ where } \theta \text{ is in radians}$$

$$\text{Sector area} = \frac{1}{2} r^2 \theta, \text{ where } \theta \text{ is in radians}$$

Trigonometry

$$\frac{a}{\sin A} = \frac{b}{\sin B} = \frac{c}{\sin C}$$

$$a^2 = b^2 + c^2 - 2bc \cos A$$

Statistics

$$\text{Mean} = \frac{\sum fx}{\sum f}$$

$$\text{Standard deviation} = \sqrt{\frac{\sum fx^2}{\sum f} - \left(\frac{\sum fx}{\sum f} \right)^2}$$

Answer all the questions.

- 1 A range of values of x is represented on the number line below.

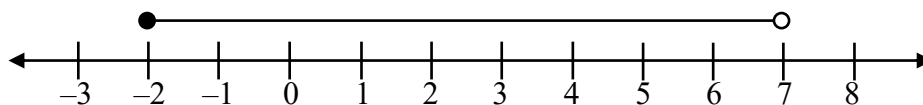

Write down inequalities that represent this range of values of x .

Answer [1]

- 2 The stem-and-leaf diagram shows the masses, in grams, of some oranges.

19	1	2	2	m	5	6	6	8
20	0	0	3	4	6			
21	1	4	7					

Key: 19 | 2 represents 192 grams

- (a) Find the median of these masses.

Answer median = g [1]

- (b) Given that the interquartile range is 10, find the value of m .

Answer m = [2]

- 3 Given that $2^{x+1} + 2^x = 24$, find the value of x .

Answer x = [2]

- 4 The diagram shows part of the curve $y = ax^2 + bx + 10$. It cuts the x -axis at 5 and the coordinates of the maximum point is (1.5, 12.25). Find the value of a and of b .

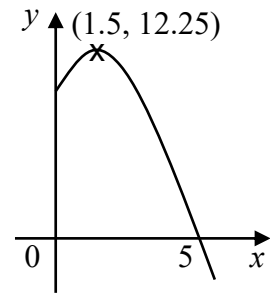

Answer $a = \dots\dots\dots$

$b = \dots\dots\dots$

[3]

- 5 The first four terms in a sequence of numbers $T_1, T_2, T_3, T_4, \dots$, are given below.

$$\frac{1}{3}, \frac{7}{15}, \frac{13}{35}, \frac{19}{63}, \dots$$

Find an expression, in terms of n , for T_n .

Answer $T_n = \dots\dots\dots$ [2]

- 6 The diagram shows an irregular polygon. Find the sum of all interior angles of this polygon.

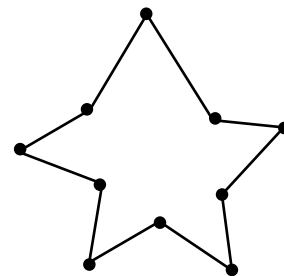

Answer $\dots\dots\dots^\circ$ [2]

- 7 The diagram shows the speed-time graph of a remote controlled toy car for the first 30 seconds of the journey.

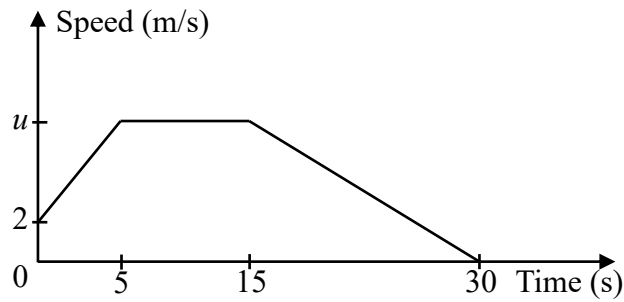

- (a) Given that the deceleration of the car is 0.5 m/s^2 , find the greatest speed, $u \text{ m/s}$.

Answer $u = \dots\dots\dots$ [1]

- (b) Calculate the average speed of the car for the first 30 seconds of the journey.

Answer $\dots\dots\dots \text{ m/s}$ [2]

- (c) Sketch the distance-time graph below for the car's journey.

Answer

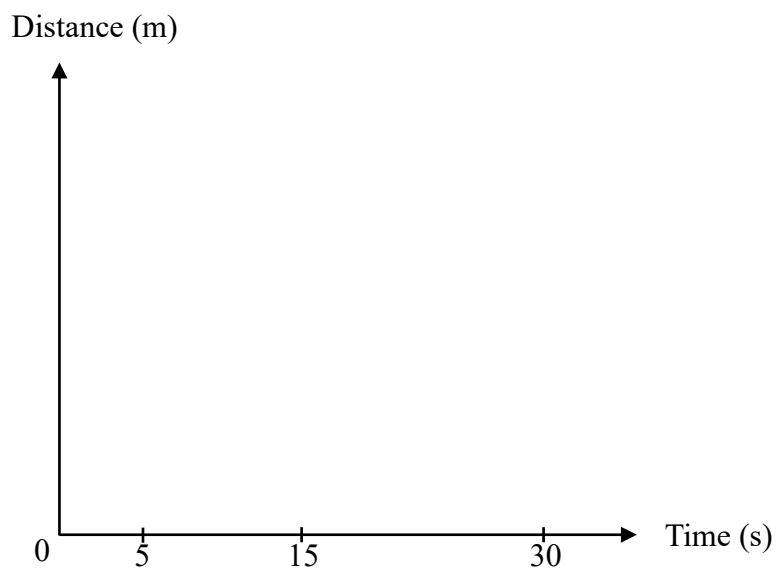

[3]

- 8** $\varepsilon = \{\text{natural number less than 10}\}$
 $A = \{\text{factors of 6}\}$
 $B = \{\text{prime numbers}\}$
 $C = \{\text{perfect squares}\}$

Use one of the symbols below to complete each statement.

$\emptyset \quad \in \quad \subseteq \quad \subset \quad \notin$

(a) $B \cap C = \dots\dots\dots$ [1]

(b) $\{2, 3\} \dots\dots\dots A$ [1]

(c) $8 \dots\dots\dots (A \cup B)' \cap C'$ [1]

- 9** (a) Factorise $9x^2 - 3x - 16y^2 + 4y$ completely.

Answer $\dots\dots\dots$ [2]

- (b) Given that $(2x - 1)^4 + (y + 2)^4 = 0$, find the value of $x - y$.

Answer $x - y = \dots\dots\dots$ [3]

- 10 The diagram shows a milk container which is made up of a frustum and a cylinder. The height, h cm, of the cylinder is the same as the height of the frustum. The radius of the cylinder base is twice the radius of the top circular surface of the frustum, r cm. Given that the **curved** surface areas of the frustum and cylinder are equal, find an expression for h , in terms of r .

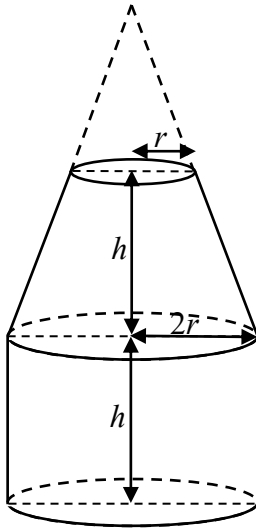

Answer $h = \dots\dots\dots$ [3]

- 11 Solve $\frac{2}{1-x^2} - \frac{3}{x-1} = 5$.

Answer $x = \dots\dots\dots$ [3]

- 12 In the diagram $PQRS$ represents a plot of land. A multi-storey carpark is to be built within $PQRS$ with the following conditions:
- nearer to PS than PQ ,
 - nearer to P than S and
 - nearer to Q than P .

Shade the region where the carpark is to be built.

[3]

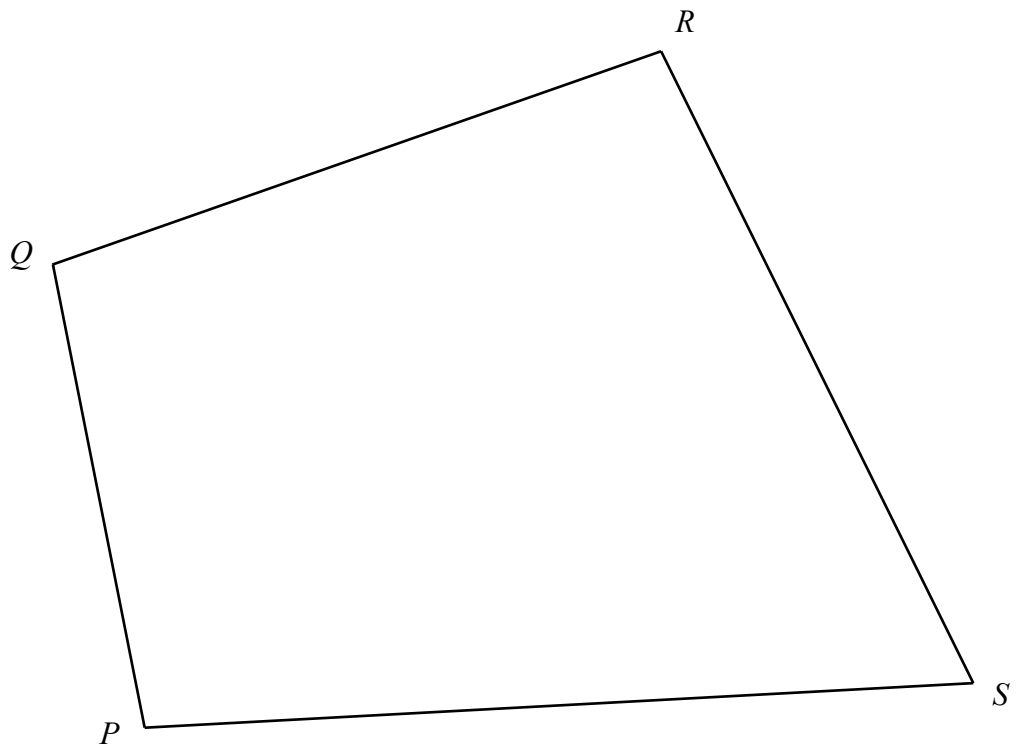

13 Given ABC is a triangle where $\overrightarrow{AB} = \begin{pmatrix} 5 \\ -1 \end{pmatrix}$ and $\overrightarrow{AC} = \begin{pmatrix} -1 \\ 8 \end{pmatrix}$.

(a) Find \overrightarrow{BC} .

Answer [2]

(b) Hence, or otherwise, show that $\angle BAC = 108.4^\circ$.

Answer

[2]

(c) Hence, calculate the area of ΔABC .

Answer units^2 [3]

- 14 Four numbers a, b, c, d are such that $a + b + c + d = 14$ and $a^2 + b^2 + c^2 + d^2 = 54$.
 When the fifth number, e , is added, the standard deviation of the five numbers became 1.
 Find the value of e .

Answer $e = \dots\dots\dots$ [3]

- 15 The line graph below shows the profit made by Company X over the 4 years.

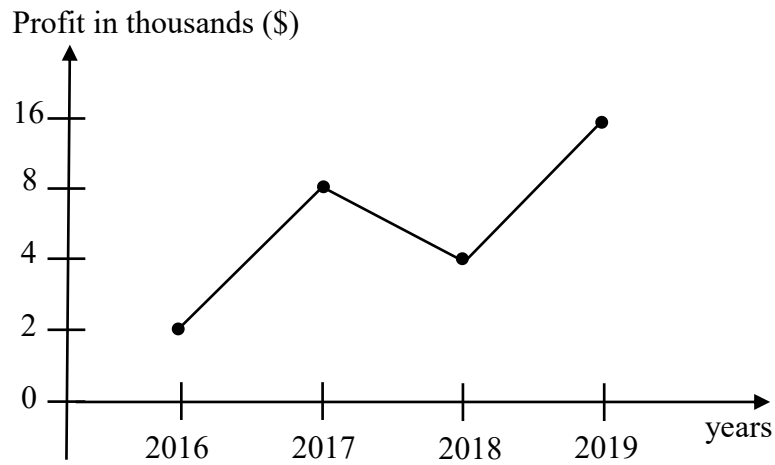

State one aspect of the graph that may be misleading and explain how this may lead to a misinterpretation of the graph.

Answer

.....

..... [2]

- 16** The diagram shows a circle ABC , with centre O . AC is the diameter of the circle. M is the midpoint of chord AB and TAP is tangent to the circle at point A .

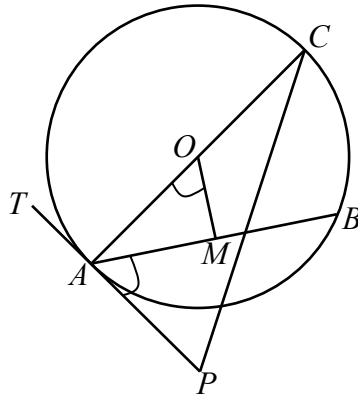

Show, with reasons, that $\angle BAP = \angle AOM$.

Answer

[3]

- 17** Mrs Teo wishes to open an account with a bank by investing \$5000 for 5 years.
 Bank A offers 3% per annum, compounded half-yearly.
 Bank B offers $r\%$ per annum simple interest.
 Given that both banks offer the same amount of interest at the end of 5 years, find the value of r .

Answer $r = \dots\dots\dots$ [3]

18

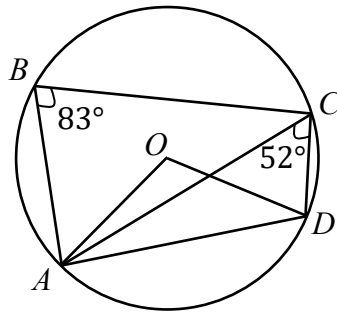

In the diagram, A , B , C and D are points on a circle, centre O .
Angle $ABC = 83^\circ$ and angle $ACD = 52^\circ$.
Find angle ODC .

Answer $\angle ODC = \dots\dots\dots^\circ$ [3]

19 (a) The volume of cube A is $1176x \text{ cm}^3$, where the length of the sides is an integer.
Find the smallest possible positive integer x .

Answer $x = \dots\dots\dots$ [2]

(b) What is the maximum number of cube A that a container of dimensions 5 m by 1m by 3 m can hold?

Answer $\dots\dots\dots$ [3]

- 20 Singapore Chinese Dance Theatre put up a production in July.
The tickets pricing for senior citizens, students and adults were \$28, \$38 and \$48 respectively.

This information can be represented by the matrix $\mathbf{Q} = \begin{pmatrix} 28 \\ 38 \\ 48 \end{pmatrix}$

- (a) 2 senior citizens, 15 students and 10 adults order tickets through NC School.
21 students and x adults order tickets through RV School.
Represent this information in a 2×3 matrix \mathbf{P} .

$$\text{Answer } \mathbf{P} = \begin{pmatrix} & & \\ & & \end{pmatrix} \begin{matrix} NC \\ RV \end{matrix} \quad [1]$$

- (b) Find the matrix \mathbf{R} , in terms of x , such that $\mathbf{R} = \mathbf{PQ}$.

$$\text{Answer } \mathbf{R} = \begin{pmatrix} & & \\ & & \end{pmatrix} \quad [1]$$

- (c) Explain what each element in matrix \mathbf{R} represents.

.....
..... [1]

- (d) The total amount of money collected from NC School is less than RV School.
Work out the least value of x .

$$\text{Answer } x = \dots\dots\dots [2]$$

- (e) All tickets ordered through school will be entitled to a 25% discount for senior citizens, 20% discount for students and 15% discount for adults. Write down matrix \mathbf{D} such that the elements in matrix multiplication of \mathbf{PDQ} gives the total amount of money collected from each school after discount.

$$\text{Answer } \mathbf{D} = \begin{pmatrix} & & \\ & & \\ & & \end{pmatrix} \quad [1]$$

21 Anna and Betty have been given a task to complete 24 stamps in 15 days.
If Anna fall sick after 12 days, Betty will take additional 2 days to complete the task.
If Betty fall sick after 12 days, Anna will take additional n days to complete the task.

(a) Find the value of n .

Answer $n = \dots\dots\dots$ [4]

(b) State an assumption you have made for part **(a)**.

Answer $\dots\dots\dots$ [1]

22 The cost of a mobile phone plan, $\$C$, with respect to the amount of additional talktime, t minutes, by the user can be represented by the graph below.

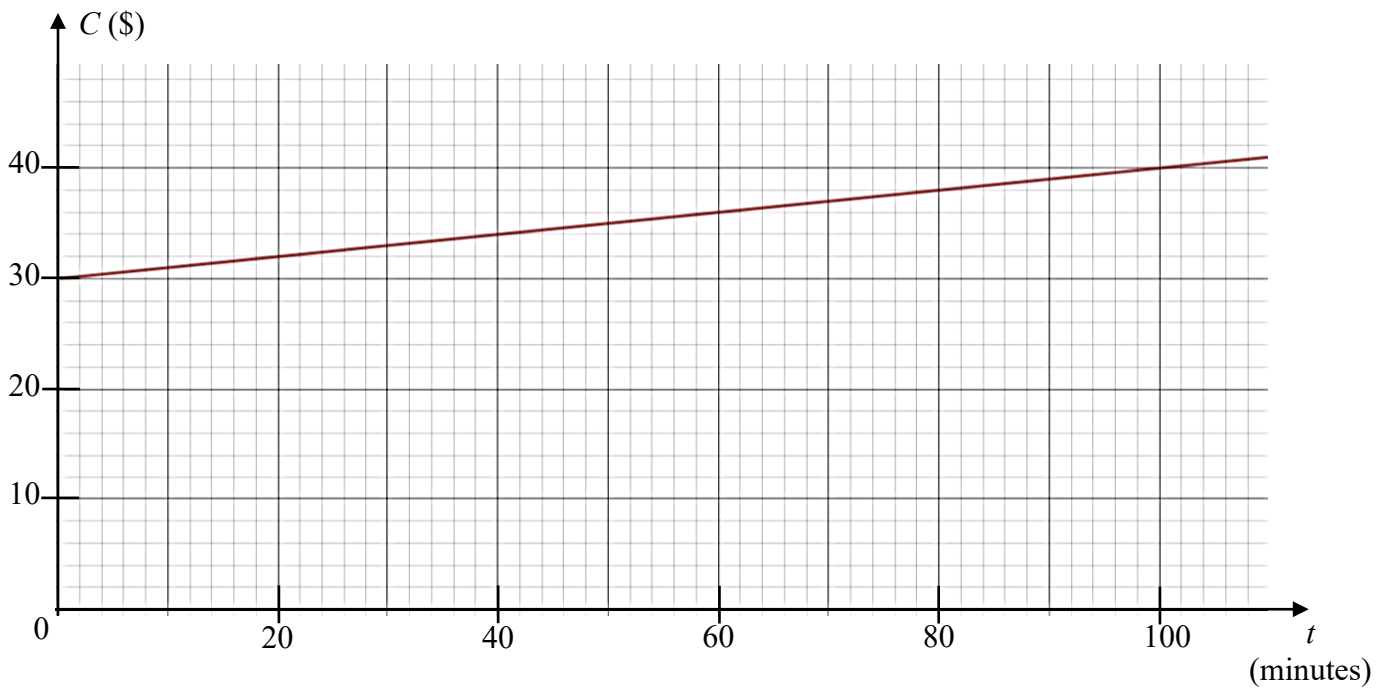

(a) State the equation of this line.

Answer [1]

(b) Explain what the vertical C -intercept value represents.

Answer
 [1]

(c) Give a reason why the cost is **not** directly proportional to the additional talktime.

Answer
 [1]

23 The graph of $y = \frac{1}{x-1} + 2$ is drawn on the grid.

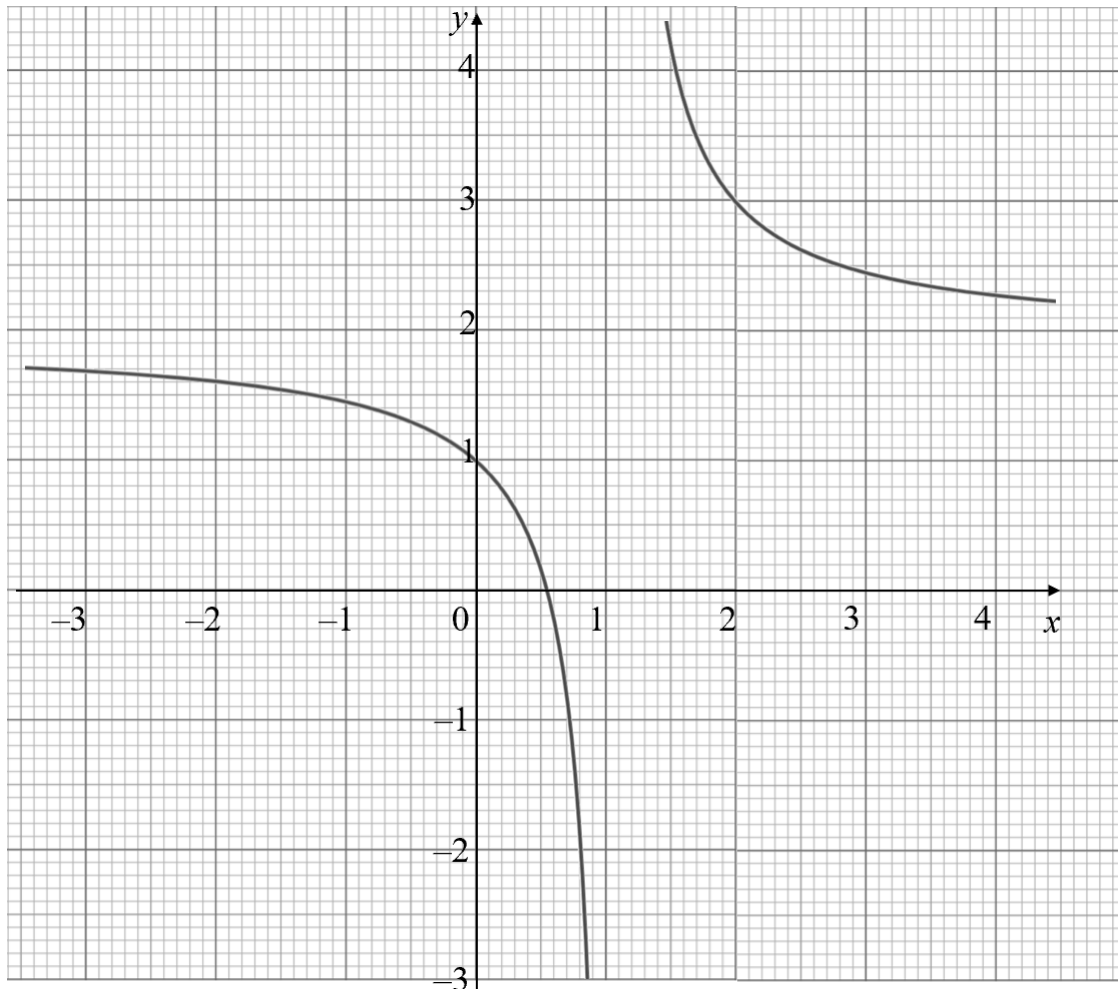

(a) The equation $x^2 - x = 1$ can be solved by drawing a suitable straight line on the grid. Find the equation of this straight line.

Answer [2]

(b) By drawing the straight line from part (a), solve the equation $x^2 - x = 1$.

Answer $x = \dots\dots\dots$ or $\dots\dots\dots$ [2]

Answers

1	$-2 \leq x < 7$	14	3.5
2a	199	15	The vertical axis is inconsistent, hence making the increase from 2016 to 2017 looks the same as the increase from 2018 to 2019, but the actual is lesser.
2b	5		Or
3	3		The data for 2019 is invalid. There can be a decrease instead of increase.
4	$a = -1$, $b = 3$	16	Shown
5	$\frac{6n - 5}{4n^2 - 1}$	17	3.21
6	1440	18	59
7a	7.5	19a	63
7b	$5\frac{1}{6}$	19b	154
7c		20a	$\mathbf{P} = \begin{pmatrix} 2 & 15 & 10 \\ 0 & 21 & x \end{pmatrix}$
8a	\emptyset	20b	$\mathbf{R} = \begin{pmatrix} 1106 \\ 798 + 48x \end{pmatrix}$
8b	\subset	20c	It represents the total amount collected/ to be paid by NC and RV respectively.
8c	\in	20d	$x = 7$
9a	$(3x - 4y)(3x + 4y - 1)$	20e	$\mathbf{D} = \begin{pmatrix} 0.75 & 0 & 0 \\ 0 & 0.8 & 0 \\ 0 & 0 & 0.85 \end{pmatrix}$
9b	2.5	21a	3.5
10	$1.13r$	21b	Both Anna and Betty worked at a constant rate.
11	0 or 0.6	22a	$C = 30 + 0.1t$
12		22b	It represents the basic cost without any additional talktime.
13a	$\begin{pmatrix} -6 \\ 9 \end{pmatrix}$	22c	The graph does not start from origin. Or $\frac{c}{t} \neq \text{constant.}$
13b	Shown	23a	$y = x + 2$
13c	19.5	23b	Accept -0.6 ± 0.05 and 1.6 ± 0.05

Name: **ANSWERS** Register Number: Class:

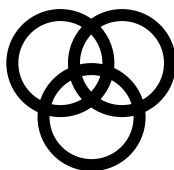

南橋中學

**NAN CHIAU HIGH SCHOOL
PRELIMINARY EXAMINATION (2) 2018
SECONDARY FOUR EXPRESS**

For Marker's Use

MATHEMATICS

4048/01

Paper 1

6 August 2018, Monday

2 hours

Candidates answer on the Question Paper

READ THESE INSTRUCTIONS FIRST

Write your name, class and index number on all the work you hand in.

Write in dark blue or black pen.

You may use a 2B pencil for any diagrams or graphs.

Do not use staples, paper clips, highlighters, glue or correction fluid.

Answer **all** questions.

If working is needed for any question it must be shown with the answer.

Omission of essential working will result in loss of marks.

The use of an approved calculator is expected, where appropriate.

If the degree of accuracy is not specified in the question, and if the answer is not exact, give the answer to three significant figures. Give answers in degrees to one decimal place.

For π , use either your calculator value or 3.142, unless the question requires the answer in terms of π .

The number of marks is given in brackets [] at the end of each question or part question.

The total marks for this paper is 80.

Setter: Ms Ting Shi Yun

Mathematical Formulae

Compound interest

$$\text{Total amount} = P \left(1 + \frac{r}{100} \right)^n$$

Mensuration

$$\text{Curved surface area of a cone} = \pi r l$$

$$\text{Surface area of a sphere} = 4\pi r^2$$

$$\text{Volume of a cone} = \frac{1}{3} \pi r^2 h$$

$$\text{Volume of a sphere} = \frac{4}{3} \pi r^3$$

$$\text{Area of triangle } ABC = \frac{1}{2} ab \sin C$$

$$\text{Arc length} = r\theta, \text{ where } \theta \text{ is in radians}$$

$$\text{Sector area} = \frac{1}{2} r^2 \theta, \text{ where } \theta \text{ is in radians}$$

Trigonometry

$$\frac{a}{\sin A} = \frac{b}{\sin B} = \frac{c}{\sin C}$$

$$a^2 = b^2 + c^2 - 2bc \cos A$$

Statistics

$$\text{Mean} = \frac{\Sigma fx}{\Sigma f}$$

$$\text{Standard deviation} = \sqrt{\frac{\Sigma fx^2}{\Sigma f} - \left(\frac{\Sigma fx}{\Sigma f} \right)^2}$$

Answer all the questions.

1 A range of values of x is represented on the number line below.

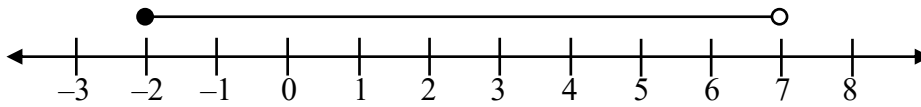

Write down inequalities that represent this range of values of x .

Answer $-2 \leq x < 7$ **B1** [1]

2 The stem-and-leaf diagram shows the masses, in grams, of some oranges.

19	1	2	2	m	5	6	6	8
20	0	0	3	4	6			
21	1	4	7					

Key: 19 | 2 represents 192 grams

(a) Find the median of these masses.

Answer median =199..... **B1**. g [1]

(b) Given that the interquartile range is 10, find the value of m .

$$205 - Q_1 = 10$$

$$Q_1 = 195 \quad \mathbf{M1}$$

$$\therefore m = 5 \quad \mathbf{A1}$$

Answer $m =$ 5..... [2]

3 Given that $2^{x+1} + 2^x = 24$, find the value of x .

$$2^x(2 + 1) = 24$$

$$2^x = 8 \quad \mathbf{M1}$$

$$2^x = 2^3$$

$$\therefore x = 3 \quad \mathbf{A1}$$

Answer $x =$ 3..... [2]

- 4 The diagram shows part of the curve $y = ax^2 + bx + 10$. It cuts the x -axis at 5 and the coordinates of the maximum point is (1.5, 12.25). Find the value of a and of b .

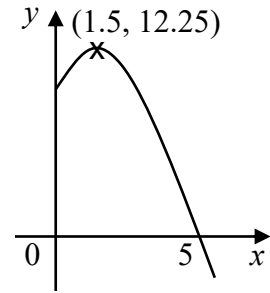

$$y = a(x - 1.5)^2 + 12.25$$

$$y = a(x^2 - 3x + 2.25) + 12.25$$

$$\therefore a(2.25) + 12.25 = 10 \quad \mathbf{M1}$$

$$a = -1 \quad \mathbf{A1}$$

$$\therefore b = 3 \quad \mathbf{B1}$$

$$\text{Answer } a = \dots\dots\dots -1$$

$$b = \dots\dots\dots 3 \quad [3]$$

- 5 The first four terms in a sequence of numbers $T_1, T_2, T_3, T_4, \dots$, are given below.

$$\frac{1}{3}, \frac{7}{15}, \frac{13}{35}, \frac{19}{63}, \dots$$

Find an expression, in terms of n , for T_n .

Note: If students only find numerator or denominator, award **B1**

$$\text{Answer } T_n = \dots\dots\dots \frac{6n - 5}{4n^2 - 1} \quad \mathbf{B2} \quad [2]$$

- 6 The diagram shows an irregular polygon. Find the sum of all interior angles of this polygon.

$$8 \times 180 \quad \mathbf{M1}$$

$$= 1440^\circ \quad \mathbf{A1}$$

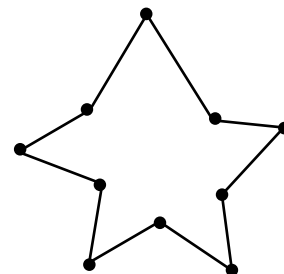

$$\text{Answer } \dots\dots\dots 1440 \dots\dots\dots^\circ \quad [2]$$

- 7 The diagram shows the speed-time graph of a remote controlled toy car for the first 30 seconds of the journey.

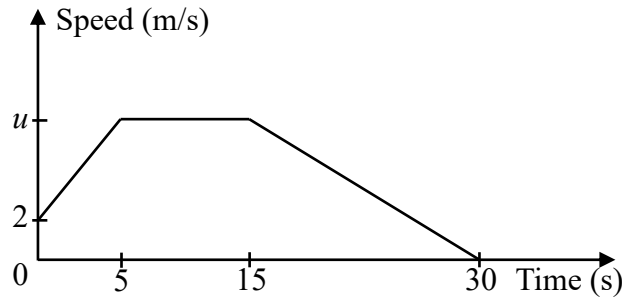

- (a) Given that the deceleration of the car is 0.5 m/s^2 , find the greatest speed, $u \text{ m/s}$.

Answer $u = \dots\dots\dots 7.5$ **B1** [1]

- (b) Calculate the average speed of the car for the first 30 seconds of the journey.

$$\begin{aligned} \text{Total distance} &= \frac{1}{2}(2 + 7.5)(5) + (7.5)(10) + \frac{1}{2}(7.5)(15) \\ &= 23.75 + 75 + 56.25 \\ &= 155 \end{aligned} \quad \text{M1}$$

$$\text{Average speed} = \frac{155}{30} = 5\frac{1}{6} \quad \text{A1}$$

Only accept exact proper fraction

Answer $\dots\dots\dots 5\frac{1}{6}$ m/s [2]

- (c) Sketch the distance-time graph below for the car's journey.

Answer

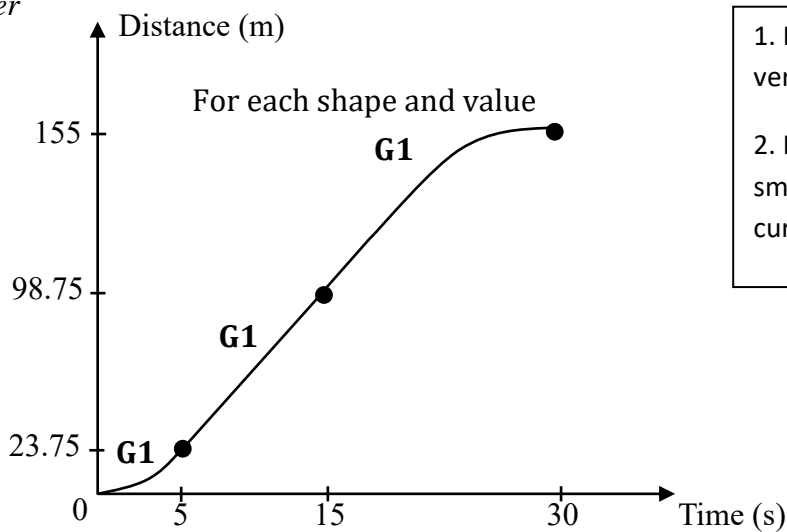

1. Missing markings on vertical axis: -1 mark

2. If the sketch is not smooth (a.k.a. pimply curve), -1 mark

[3]

- 8 $\varepsilon = \{\text{natural number less than 10}\} = \{1, 2, 3, 4, 5, 6, 7, 8, 9\}$
 $A = \{\text{factors of 6}\} = \{1, 2, 3, 6\}$
 $B = \{\text{prime numbers}\} = \{2, 3, 5, 7\}$
 $C = \{\text{perfect squares}\} = \{1, 4, 9\}$

Use one of the symbols below to complete each statement.

$\emptyset \quad \in \quad \subseteq \quad \subset \quad \notin$

(a) $B \cap C = \dots\dots\dots \emptyset$ **B1** [1]

(b) $\{2, 3\} \dots\dots\dots \subset A$ **B1** [1]

(c) $8 \dots\dots\dots \in (A \cup B)' \cap C'$ **B1** [1]

- 9 (a) Factorise $9x^2 - 3x - 16y^2 + 4y$ completely.

$$9x^2 - 16y^2 - 3x + 4y$$

$$= (3x - 4y)(3x + 4y) - (3x - 4y) \quad \mathbf{M1}$$

$$= (3x - 4y)(3x + 4y - 1) \quad \mathbf{A1}$$

Answer $(3x - 4y)(3x + 4y - 1)$ [2]

- (b) Given that $(2x - 1)^4 + (y + 2)^4 = 0$, find the value of $x - y$.

Since $(2x - 1)^4 \geq 0$ and $(y + 2)^4 \geq 0$, **B1** reason

$$2x - 1 = 0 \quad \text{and} \quad y + 2 = 0$$

$$x = \frac{1}{2} \quad \text{and} \quad y = -2 \quad \mathbf{M1}$$

$$\therefore x - y = 2.5 \quad \mathbf{A1}$$

Answer $x - y = \dots\dots\dots 2.5$ [3]

- 10** The diagram shows a milk container which is made up of a frustum and a cylinder. The height, h cm, of the cylinder is the same as the height of the frustum. The radius of the cylinder base is twice the radius of the top circular surface of the frustum, r cm. Given that the **curved** surface areas of the frustum and cylinder are equal, find an expression for h , in terms of r .

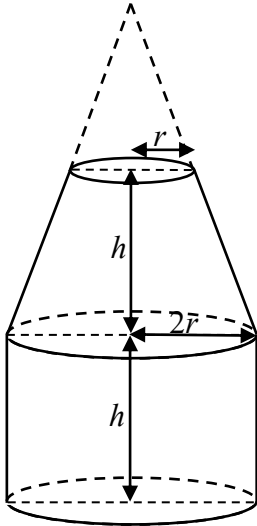

$$\frac{\text{Area}_{\text{small cone}}}{\text{Area}_{\text{big cone}}} = \left(\frac{1}{2}\right)^2 = \frac{1}{4}$$

$$\text{Surface area of frustum} = 3\pi r\sqrt{h^2 + r^2} \quad \text{M1}$$

$$3\pi r\sqrt{h^2 + r^2} = 2\pi(2r)h \quad \text{M1}$$

$$3\sqrt{h^2 + r^2} = 4h$$

$$9(h^2 + r^2) = 16h^2$$

$$9r^2 = 7h^2$$

$$h^2 = \frac{9r^2}{7}$$

$$h = \frac{3}{\sqrt{7}}r \quad \text{or} \quad \frac{3\sqrt{7}}{7}r \quad \text{or} \quad 1.13r \quad \text{A1}$$

Answer $h = \dots\dots\dots 1.13r$ [3]

- 11** Solve $\frac{2}{1-x^2} - \frac{3}{x-1} = 5$.

$$\frac{2}{(1-x)(1+x)} + \frac{3}{1-x} = 5$$

$$\frac{2 + 3(1+x)}{(1-x)(1+x)} = 5 \quad \text{M1}$$

$$2 + 3(1+x) = 5(1-x)(1+x)$$

$$5x^2 + 3x = 0 \quad \text{M1}$$

$$x(5x + 3) = 0$$

$$x = 0 \quad \text{or} \quad x = -\frac{3}{5} \quad \text{A1}$$

Answer $x = \dots\dots\dots 0 \quad \text{or} \quad -\frac{3}{5}$ [3]

12 In the diagram $PQRS$ represents a plot of land. A multi-storey carpark is to be built within $PQRS$ with the following conditions:

- nearer to PS than PQ ,
- nearer to P than S and
- nearer to Q than P .

Shade the region where the carpark is to be built.

[3]

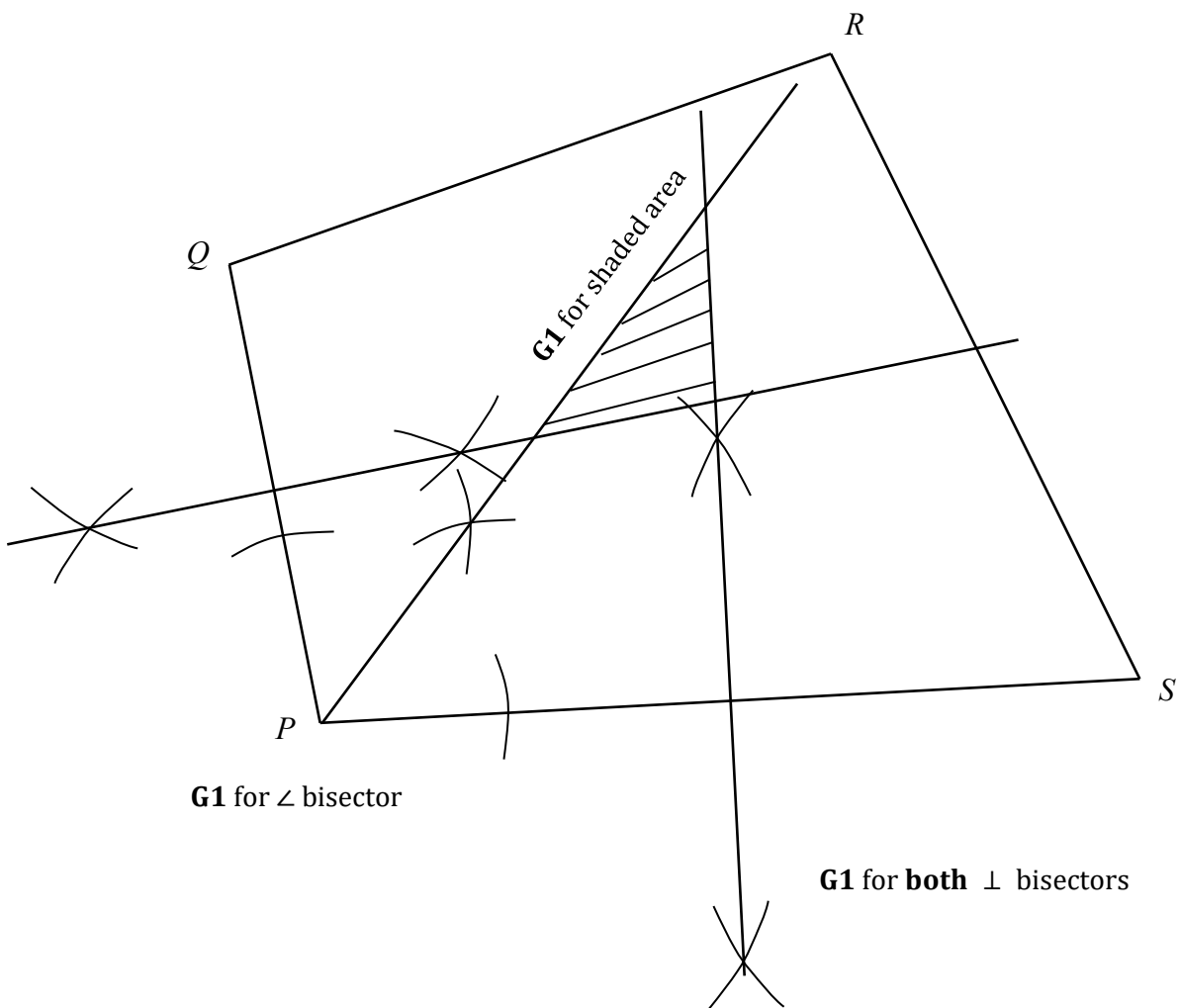

13 Given ABC is a triangle where $\overrightarrow{AB} = \begin{pmatrix} 5 \\ -1 \end{pmatrix}$ and $\overrightarrow{AC} = \begin{pmatrix} -1 \\ 8 \end{pmatrix}$.

(a) Find \overrightarrow{BC} .

$$\begin{aligned} \overrightarrow{BC} &= \overrightarrow{BA} + \overrightarrow{AC} \\ &= -\begin{pmatrix} 5 \\ -1 \end{pmatrix} + \begin{pmatrix} -1 \\ 8 \end{pmatrix} \quad \mathbf{M1} \\ &= \begin{pmatrix} -6 \\ 9 \end{pmatrix} \quad \mathbf{A1} \end{aligned}$$

Answer $\begin{pmatrix} -6 \\ 9 \end{pmatrix}$ [2]

(b) Hence, or otherwise, show that $\angle BAC = 108.4^\circ$.

Answer

“Hence” method

$$\begin{aligned} |\overrightarrow{BC}| &= \sqrt{117} \\ |\overrightarrow{AB}| &= \sqrt{26} \\ |\overrightarrow{AC}| &= \sqrt{65} \\ 117 &= 26 + 65 - (\sqrt{26})(\sqrt{65})\cos\angle BAC \quad \mathbf{M1} \\ \cos\angle BAC &= -0.3162277 \\ \angle BAC &= 108.4^\circ \quad \mathbf{A1} \end{aligned}$$

“Otherwise” method

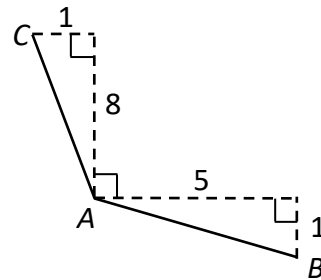

$$\begin{aligned} \angle BAC &= 90 + \tan^{-1}\frac{1}{5} + \tan^{-1}\frac{1}{8} \quad \mathbf{M1} \\ &= 108.4^\circ \quad \mathbf{A1} \end{aligned}$$

(c) Hence, calculate the area of ΔABC .

$$\begin{aligned} \text{Area} &= \frac{1}{2}(\sqrt{26})(\sqrt{65}) \sin 108.4 \quad \mathbf{M1} \text{ length of AB and AC} \\ &= 19.5 \text{ units}^2 \quad \mathbf{M1} \text{ formula} \\ & \quad \mathbf{A1} \end{aligned}$$

If students calculate the length in part (b), award them the M1 too.

Answer 19.5 units²

[3]

- 14 Four numbers a, b, c, d are such that $a + b + c + d = 14$ and $a^2 + b^2 + c^2 + d^2 = 54$.
When the fifth number, e , is added, the standard deviation of the five numbers became 1.
Find the value of e .

$$\sqrt{\frac{54 + e^2}{5} - \left(\frac{14 + e}{5}\right)^2} = 1 \quad \text{M1}$$

$$\frac{5(54 + e^2) - (14 + e)^2}{25} = 1$$

$$270 + 5e^2 - 196 - 28e - e^2 = 25$$

$$4e^2 - 28e + 49 = 0 \quad \text{M1}$$

$$(2e - 7)^2 = 0$$

$$e = 3.5 \quad \text{A1}$$

Answer $e = \dots\dots\dots 3.5 \dots\dots\dots$ [3]

- 15 The line graph below shows the profit made by Company X over the 4 years.

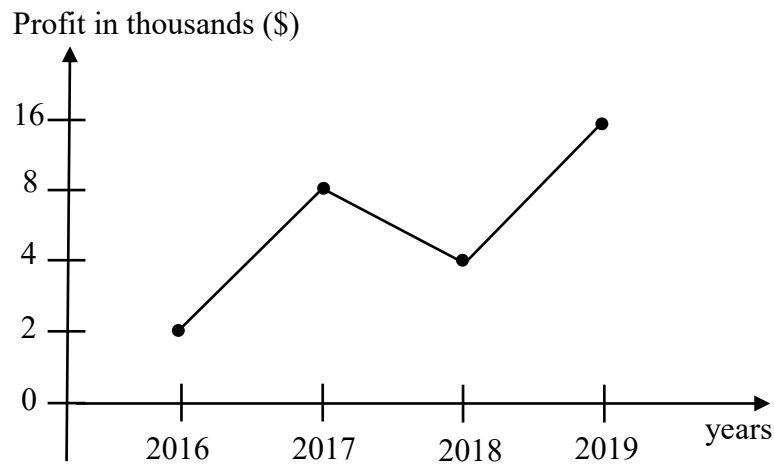

State one aspect of the graph that may be misleading and explain how this may lead to a misinterpretation of the graph.

B1

Answer The vertical axis is inconsistent, hence making the increase from 2016 to 2017
looks the same as the increase from 2018 to 2019, but the actual is lesser. **B1**

OR The data for 2019 is invalid. There can be a decrease instead of increase. [2]

B1

B1

- 16 The diagram shows a circle ABC , with centre O . AC is the diameter of the circle. M is the midpoint of chord AB and TAP is tangent to the circle at point A .

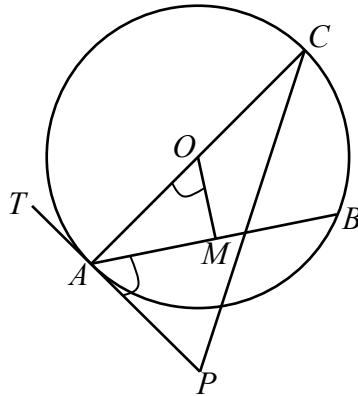

Show, with reasons, that $\angle BAP = \angle AOM$.

Answer

$$\begin{aligned} \angle OAP &= 90^\circ \quad (\text{Tangent perpendicular to radius}) && \mathbf{M1} \\ \angle AMO &= 90^\circ \quad (\text{Perpendicular bisector of chord}) && \mathbf{M1} \\ \angle AOM &= 180 - 90 - \angle OAM \quad (\angle \text{sum of } \Delta) \\ &= 90 - (90 - \angle BAP) \\ &= \angle BAP && \mathbf{A1} \end{aligned}$$

Any missing reasons:
overall -1 mark.

[3]

- 17 Mrs Teo wishes to open an account with a bank by investing \$5000 for 5 years.
Bank A offers 3% per annum, compounded half-yearly.
Bank B offers $r\%$ per annum simple interest.
Given that both banks offer the same amount of interest at the end of 5 years, find the value of r .

$$\begin{aligned} \text{Interest} &= 5000 \left(1 + \frac{3}{200}\right)^{10} - 5000 && \mathbf{M1} \\ \frac{5000 \times r \times 5}{100} &= 802.7041 && \mathbf{M1} \\ 250r &= 802.7041 \\ r &= 3.21 && \mathbf{A1} \end{aligned}$$

If student write 3.21% on
answer blank, -1 mark.

Answer $r = \dots\dots\dots 3.21$ [3]

18

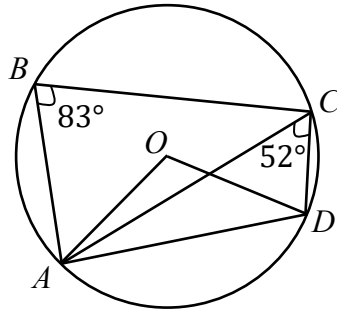

In the diagram, A, B, C and D are points on a circle, centre O .
 Angle $ABC = 83^\circ$ and angle $ACD = 52^\circ$.
 Find angle ODC .

Any missing reasons:
overall -1 mark.

$\angle AOD = 52 \times 2 = 104^\circ$ (\angle at centre = $2\angle$ at circumference)	M1
$\angle ODA = (180 - 104) \div 2 = 38^\circ$ (base of isosceles Δ)	M1
$\angle ODC = 180 - 83 - 38$ (\angle in opposite segment)	} A1
$= 59^\circ$	

Answer $\angle ODC = \overset{59}{\dots\dots\dots}^\circ$ [3]

19 (a) The volume of cube A is $1176x \text{ cm}^3$, where the length of the sides is an integer.
 Find the smallest possible positive integer x .

$1176 = 2^3 \times 3 \times 7^2$ **M1**

$\therefore x = 3^2 \times 7 = 63$ **A1**

Answer $x = \overset{63}{\dots\dots\dots}$ [2]

(b) What is the maximum number of cube A that a container of dimensions 5 m by 1 m by 3 m can hold?

Length of cube = $2 \times 3 \times 7 = 42$ **M1**

$\frac{500}{42} = 11 \frac{19}{21}$	}	M1
$\frac{100}{42} = 2 \frac{8}{21}$		
$\frac{300}{42} = 7 \frac{1}{7}$		

No. of cubes = $11 \times 2 \times 7 = 154$ **A1**

Answer $\overset{154}{\dots\dots\dots}$ [3]

- 20 Singapore Chinese Dance Theatre put up a production in July.
The tickets pricing for senior citizens, students and adults were \$28, \$38 and \$48 respectively.

This information can be represented by the matrix $\mathbf{Q} = \begin{pmatrix} 28 \\ 38 \\ 48 \end{pmatrix}$

- (a) 2 senior citizens, 15 students and 10 adults order tickets through NC School.
21 students and x adults order tickets through RV School.
Represent this information in a 2×3 matrix \mathbf{P} .

$$\text{Answer } \mathbf{P} = \begin{pmatrix} 2 & 15 & 10 \\ 0 & 21 & x \end{pmatrix} \begin{matrix} \text{NC} \\ \text{RV} \end{matrix} \quad \mathbf{B1} \quad [1]$$

- (b) Find the matrix \mathbf{R} , in terms of x , such that $\mathbf{R} = \mathbf{PQ}$.

$$\text{Answer } \mathbf{R} = \begin{pmatrix} 1106 \\ 798 + 48x \end{pmatrix} \quad \mathbf{B1} \quad [1]$$

- (c) Explain what each element in matrix \mathbf{R} represents.

It represents the total amount collected/ to be paid by NC and RV respectively $\mathbf{B1}$

.....
..... [1]

- (d) The total amount of money collected from NC School is less than RV School.
Work out the least value of x .

$$798 + 48x > 1106 \quad \mathbf{M1}$$

$$x > 6\frac{5}{12}$$

$$\therefore x = 7 \quad \mathbf{A1}$$

$$\text{Answer } x = \overset{7}{\dots\dots\dots} \quad [2]$$

- (e) All tickets ordered through school will be entitled to a 25% discount for senior citizens, 20% discount for students and 15% discount for adults. Write down matrix \mathbf{D} such that the elements in matrix multiplication of \mathbf{PDQ} gives the total amount of money collected from each school after discount.

$$\text{Answer } \mathbf{D} = \begin{pmatrix} 0.75 & 0 & 0 \\ 0 & 0.8 & 0 \\ 0 & 0 & 0.85 \end{pmatrix} \quad \mathbf{B1} \quad [1]$$

21 Anna and Betty have been given a task to complete 24 stamps in 15 days.
 If Anna fall sick after 12 days, Betty will take additional 2 days to complete the task.
 If Betty fall sick after 12 days, Anna will take additional n days to complete the task.

(a) Find the value of n .

A+B: 15 days, 24 stamps
 1 day, 1.6 stamps
 3 days, 4.8 stamps left **M1** no. of stamps left

B: 5 days, 4.8 stamps
 1 day, 0.96 stamp **M1** rate of B

A: (3+n) days, 4.8 stamps
 1 day, $\frac{4.8}{3+n}$

$$\frac{4.8}{3+n} + 0.96 = 1.6 \quad \mathbf{M1}$$

$$\frac{4.8}{3+n} = 0.64$$

$$3+n = 7.5$$

$$n = 3.5 \quad \mathbf{A1}$$

Answer $n = \dots\dots\dots 3.5 \dots\dots\dots$ [4]

(b) State an assumption you have made for part (a).

Answer Both Anna and Betty worked at a constant rate. **B1**
 [1]

22 The cost of a mobile phone plan, C , with respect to the amount of additional talktime, t minutes, by the user can be represented by the graph below.

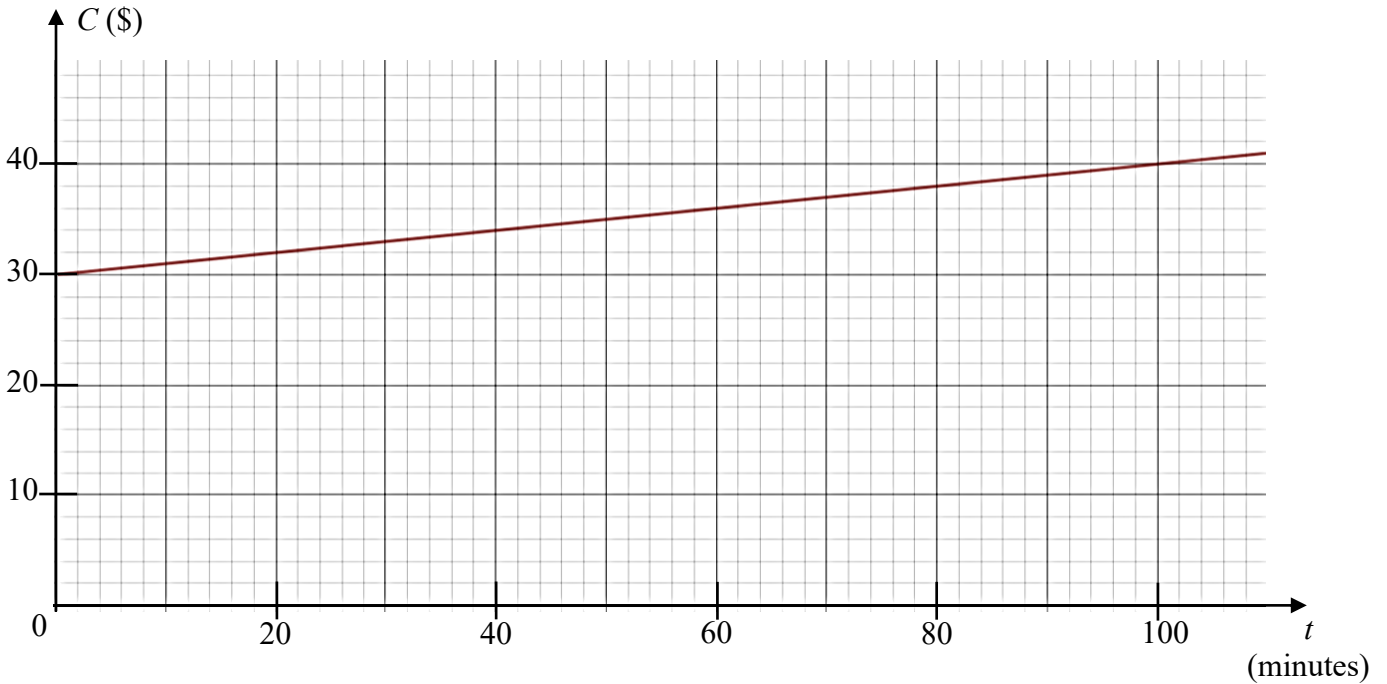

(a) State the equation of this line.

B1

Answer $C = 30 + 0.1t$ [1]

(b) Explain what the vertical C -intercept value represents.

Answer It represents the basic cost without any additional talktime. **B1**

..... [1]

(c) Give a reason why the cost is **not** directly proportional to the additional talktime.

Answer The graph does not start from origin. **B1**

OR $\frac{C}{t} \neq \text{constant}$ **B1**

Students cannot write $\frac{C}{t} \neq k$ and not defining what k is.

[1]

23 The graph of $y = \frac{1}{x-1} + 2$ is drawn on the grid.

G1

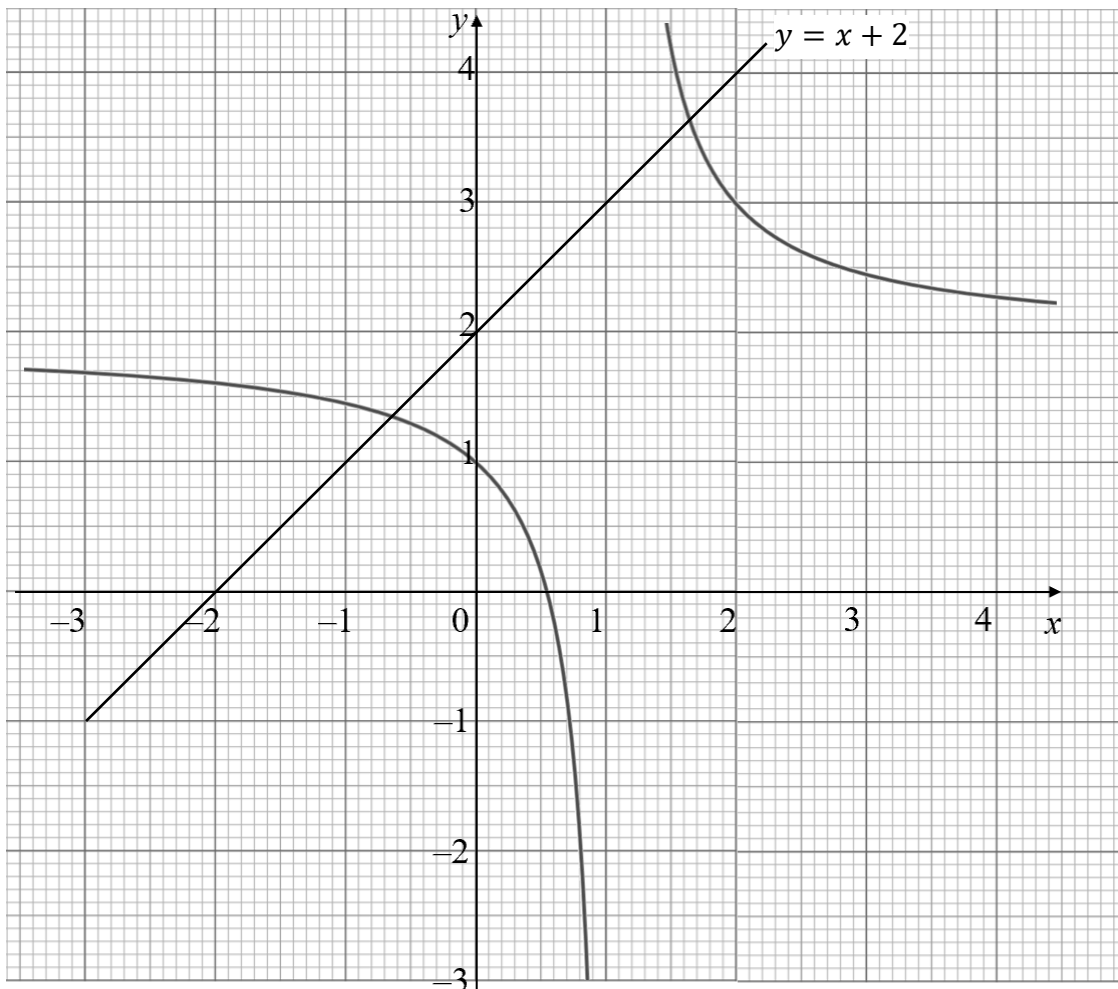

- (a) The equation $x^2 - x = 1$ can be solved by drawing a suitable straight line on the grid. Find the equation of this straight line.

$$x(x - 1) = 1 \quad \text{M1}$$

$$x = \frac{1}{x - 1}$$

$$x + 2 = \frac{1}{x - 1} + 2$$

$$y = x + 2 \quad \text{A1}$$

Answer $y = x + 2$ [2]

- (b) By drawing the straight line from part (a), solve the equation $x^2 - x = 1$.

B1 for both ans

Answer $x = \dots\dots\dots -0.65$ or $\dots\dots\dots 1.65$ [2]

Accept -0.6 ± 0.05 and 1.6 ± 0.05

~ End of paper ~

Name: _____

Register Number: _____

Class: _____

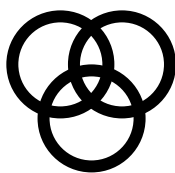

南僑中學

NAN CHIAU HIGH SCHOOL

**PRELIMINARY EXAMINATION (2) 2018
SECONDARY FOUR EXPRESS**

MATHEMATICS

4048/02

PAPER 2

10 September 2018, Monday

2 hours 30 minutes

Additional materials: Writing Papers (8 sheets)
Graph Paper (1 sheet)

READ THESE INSTRUCTIONS FIRST

Write your name, class and index number at the top of the cover page.

Write in dark blue or black pen.

You may use a pencil for any diagrams or graphs.

Do not use staples, paper clips, highlighters, glue or correction fluid.

Answer **all** questions.

If working is needed for any question it must be shown with the answer.

Omission of essential working will result in loss of marks.

Calculators should be used where appropriate.

If the degree of accuracy is not specified in the question, and if the answer is not exact, give the answer to three significant figures. Give answers in degrees to one decimal place.

For π , use either your calculator value or 3.142, unless the question requires the answer in terms of π .

At the end of the examination, fasten all your work securely together.

The number of marks is given in brackets [] at the end of each question or part question.

The total marks for this paper is **100**.

Setter: Mrs Sim Hwee Mung

Mathematical Formulae

Compound interest

$$\text{Total amount} = P \left(1 + \frac{r}{100} \right)^n$$

Mensuration

$$\text{Curved surface area of a cone} = \pi r l$$

$$\text{Surface area of a sphere} = 4\pi r^2$$

$$\text{Volume of a cone} = \frac{1}{3} \pi r^2 h$$

$$\text{Volume of a sphere} = \frac{4}{3} \pi r^3$$

$$\text{Area of triangle } ABC = \frac{1}{2} ab \sin C$$

$$\text{Arc length} = r\theta, \text{ where } \theta \text{ is in radians}$$

$$\text{Sector area} = \frac{1}{2} r^2 \theta, \text{ where } \theta \text{ is in radians}$$

Trigonometry

$$\frac{a}{\sin A} = \frac{b}{\sin B} = \frac{c}{\sin C}$$

$$a^2 = b^2 + c^2 - 2bc \cos A$$

Statistics

$$\text{Mean} = \frac{\Sigma fx}{\Sigma f}$$

$$\text{Standard deviation} = \sqrt{\frac{\Sigma fx^2}{\Sigma f} - \left(\frac{\Sigma fx}{\Sigma f} \right)^2}$$

Answer **all** questions.

- 1
- (a) Simplify $\frac{(2xy)^2}{35xy^7} \div \left(\frac{x^{-1}y^{-2}}{4}\right)^{-2}$, leaving your answer in positive index form. [2]
- (b) Solve the inequality $\frac{1}{4}x - \frac{3}{5}\left(x + \frac{1}{3}\right) \geq \frac{1}{2}(x - 9)$. [2]
- (c) (i) Express $\frac{2}{1-2x} + \frac{3(x-1)}{2x^2-5x+2} + \frac{1}{x-2}$ as a single fraction in its simplest form. [4]
- (ii) Hence solve the equation $\frac{2}{1-2x} + \frac{3(x-1)}{2x^2-5x+2} + \frac{1}{x-2} = \frac{3}{x-2}$. [2]
-

- 2 (a) $PQRS$ is a parallelogram in which the coordinates of P and Q are $(p, 4)$ and $(7, 11)$ respectively. The line $9y + 27 - 7x = 0$ cuts the y -axis at R and is parallel to the line PQ .
Find
- (i) the value of p , [3]
- (ii) the coordinates of S by **vector method**. [3]
- (b) In the diagram, $WXYZ$ is a parallelogram and U is a point on ZY such that $WZ = WU$. The lines WY and UX intersect at V .

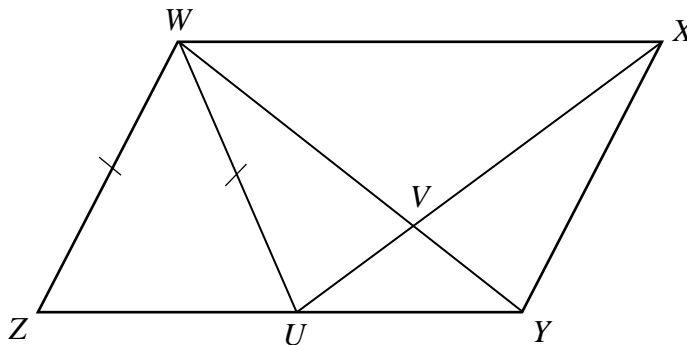

Prove that ΔWUY is congruent to ΔXYU . [3]

- 3 (a)** The radius of a particular spherical cell is approximately 6.2×10^{-11} metre.
- (i)** 88 of these spherical cells are arranged to form a straight line such that each cell touches one another without overlapping. Calculate the length, in metre, of the straight line formed. Give your answer in standard form. [1]
- (ii)** Calculate the volume of a spherical cell, in cubic centimetre. Give your answer in standard form correct to 2 decimal places. [1]
- (b)** The planet Mercury is approximately 77 billion metre from the Earth. Given that radio waves travel at a speed of 3×10^8 m/s, find the time taken for radio waves to travel from the Earth to Mercury, giving your answer to the nearest minutes. [2]
- (c)** The word ‘Googol’ is defined as 1×10^{100} . If a man has ten ‘Googol’ cents and a Boeing 737 aircraft costs \$72 million, how many such aircrafts can he buy? Give your answer in standard form correct to 5 significant figures. [3]
-

- 4 In the diagram, $\overrightarrow{OA} = 12\mathbf{p}$ and $\overrightarrow{OB} = 9\mathbf{q}$.
It is given that $3DB = 2OB$ and $OA = 3OC$.

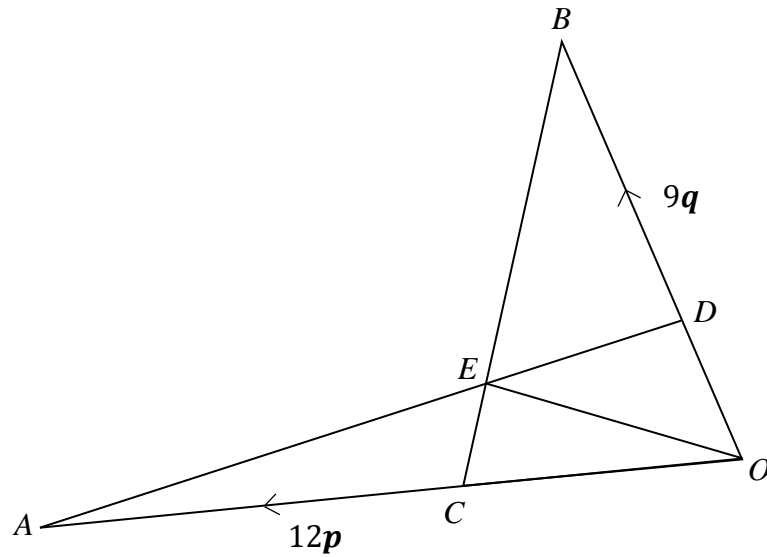

- (a) Express, as simply as possible, in terms of \mathbf{p} and \mathbf{q} ,
- (i) \overrightarrow{BC} , [2]
- (ii) \overrightarrow{DA} . [2]
- (b) Given that $\frac{\text{area of triangle } ODE}{\text{area of triangle } ODA} = \frac{1}{4}$, find \overrightarrow{OE} in terms of \mathbf{p} and \mathbf{q} . [2]
- (c) Find the value of $\frac{\text{area of triangle } BDE}{\text{area of quadrilateral } EDOC}$. [2]
-

5 Answer the whole of this question on a sheet of graph paper.

A radioactive substance decays such that its mass, m grams, after d days is given by the equation $m = 43(3)^{-d}$.

The table below shows record of the mass, m grams of the substance, corrected to 1 decimal place, after d days.

d (days)	0	1	2	3	4	5	6
m (grams)	43	14.3	4.8	p	0.5	0.2	0.1

- (a) Find the value of p . [1]
- (b) Using a horizontal scale of 2 cm to represent 1 day and a vertical scale of 2 cm to represent 5 grams, draw the graph of $m = 43(3)^{-d}$ for $0 \leq d \leq 6$. [3]
- (c) Use your graph to estimate the value of d when the mass of substance is reduced to 65% of its original mass. [1]
- (d) By drawing a tangent, find the gradient of the curve at the point when $d = 2.5$.
State briefly what this gradient represents. [3]
- (e) Using your graph, find the range of d for $86(3)^{-d} + 12d < 60$. [2]
-

- 6 PQR represents a triangular plot of land on horizontal ground.
 $PQ = 50$ km, $QR = 107$ km and $PR = 125$ km.
 R is due east of P .

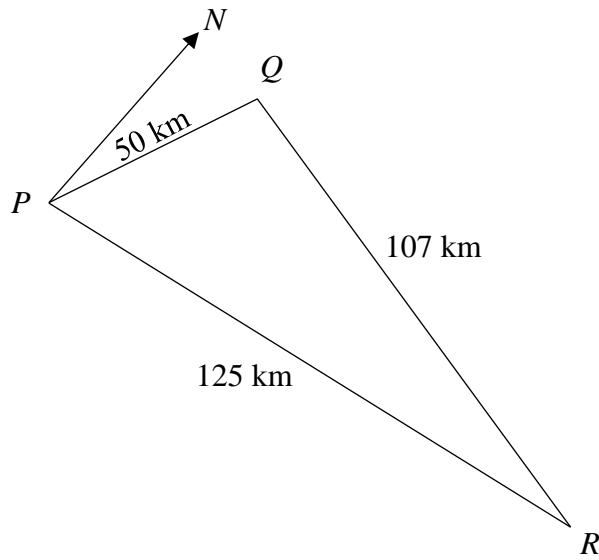

- (a) Calculate
- (i) the bearing of Q from P , [3]
 - (ii) the bearing of P from Q , [2]
 - (iii) the obtuse angle PQR , [2]
 - (iv) the area of the triangular plot of land PQR . [2]
- (b) A vertical pole of height 9 km is erected at Q . Calculate the greatest angle of elevation of the top of the pole from a point S along PR . [3]
-

- 7 In the diagram, the circle C_1 with centre X has a radius $(3r + 1)$ cm, where r is a constant. Two identical semicircles, S_1 and S_2 with centre at Y and Z respectively, have a radius $(13 - 6r)$ cm.

Another semicircle, S_3 with centre O has a diameter AB .

C_1 touches S_1 and S_2 at P and Q respectively while S_1 and S_2 touches one another at O .

S_3 touches C_1 , S_1 and S_2 at R , A and B respectively.

$AYOZB$ is a straight line.

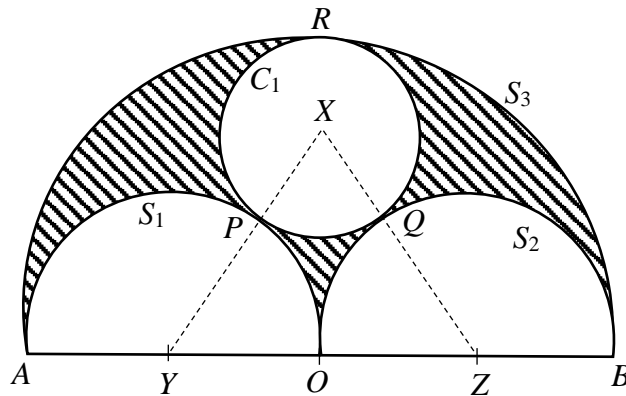

- (a) Write down an expression, in its simplest form and in terms of r , for
- (i) XZ , [1]
- (ii) XO . [2]
- (b) Hence, form an equation in terms of r and show that it reduces to $126r^2 - 411r + 299 = 0$. [3]
- (c) Solve the equation $126r^2 - 411r + 299 = 0$. [2]
- (d) Hence, find the area of the shaded region. [3]

- 8 (a) The diagram shows a circle with centre O and radius of 12 cm. AB is the diameter of the circle and AC is a tangent to the circle at A with $AC = 17$ cm. The circle intersects the line BC at D .

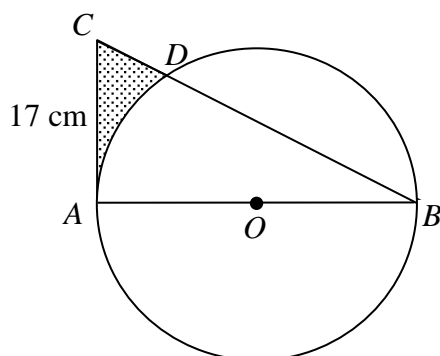

- (i) Show that angle $DOA = 1.23$ radians. [2]

Calculate

- (ii) the length of minor arc AD , [1]
 (iii) the area of the shaded region. [3]

- (b) Diagram I shows an open container which is made up of a cylinder and a cone. The cylinder has radius r cm and height 30 cm. The cone has base radius r cm and slant height l cm. The container is fully filled with water.

Diagram II shows a spherical object in which half of it is immersed into the container and some water is displaced. The radius of the sphere is the same as the radius of the cylinder. Assume the thickness of the container and the spherical object are negligible.

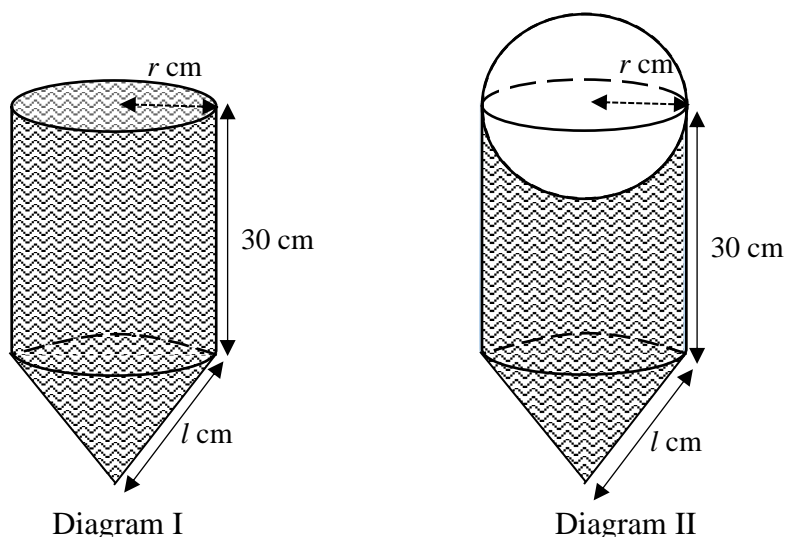

Given that the volume of the water displaced is 1152π cm³ and the volume of the water left in the container is 3600π cm³, find

- (i) the value of r and of l , [4]
 (ii) the total internal area of the container and the sphere that is in contact with water, leaving your answer in terms of π . [2]

- 9 (a) The following box-and-whisker diagrams show the distribution of the mass of 300 students from each school, SK Secondary School and HG Secondary School respectively.

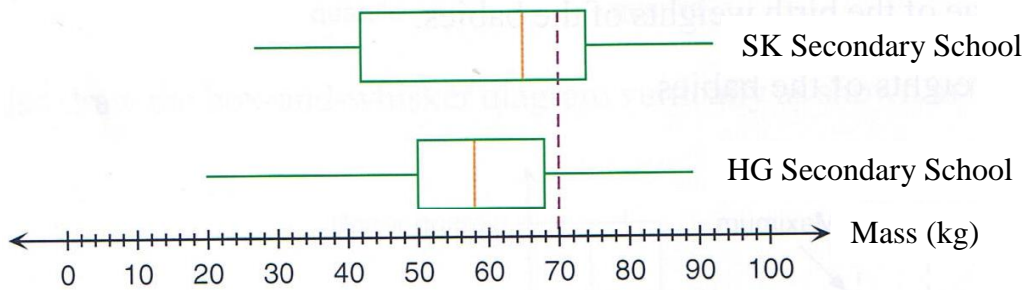

- (i) What is the median mass for each school? [1]
- (ii) Compare the mass of the students from SK Secondary School and HG Secondary School in two ways. [2]
- (iii) Mary commented that there are more students in HG Secondary School than SK Secondary School who weigh more than or equal to 70 kg. Do you agree with Mary? Support with a reason. [1]
- (b) The cumulative frequency curve shows the height distribution of 80 plants.

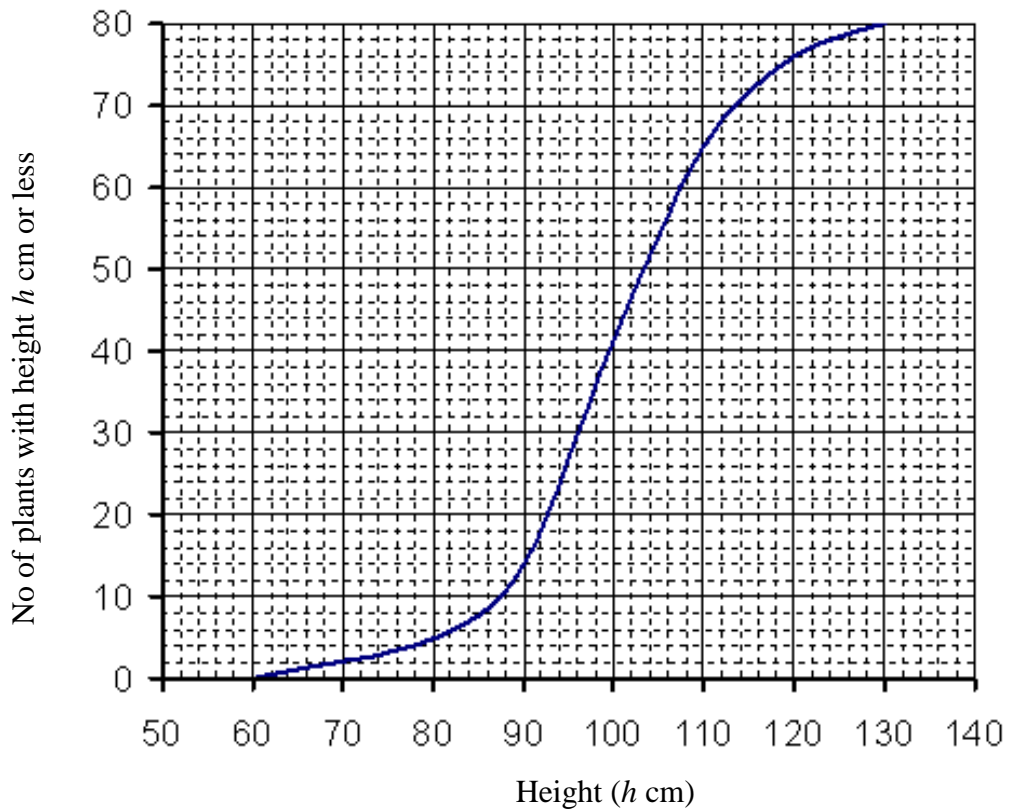

- (i) Use the graph to find
- (a) the value of m , if 32.5% of the plants have heights more than m cm, [2]
- (b) the probability that two plants chosen will each has a height of more than 118 cm. [2]
- (ii) (a) The height distribution of the 80 plants was also recorded in the following frequency table. Find the value of a and of b .

Height (h cm)	Number of plants
$60 < h \leq 70$	2
$70 < h \leq 80$	a
$80 < h \leq 90$	9
$90 < h \leq 100$	27
$100 < h \leq 110$	23
$110 < h \leq 120$	b
$120 < h \leq 130$	4

[1]

- (b) Hence find the mean and the standard deviation of the height of the 80 plants. [2]
-

10 Mr and Mrs Tan bought a 3-bedroom unit at a newly launched condominium project at Serangoon. The unit has a floor area of 1152 square foot (sqft). The selling price for the unit is at \$1494 per sqft. The developer gives a 5% early bird discount to all buyers.

(a) Calculate the price that they paid for the unit. [1]

Mr and Mrs Tan are both Singapore citizens and they also owned a HDB 5-room flat and they do not have any intention of selling their flat. As such, they will have to pay Additional Buyer's Stamp Duty (ABSD) to the government on top of the Buyer's Stamp Duty (BSD). Table 1 shows the BSD rate and Table 2 shows the ABSD rate.

Table 1. BSD

Based on purchase price	Rate
First \$180 000	1%
Next \$180 000	2%
Next \$640 000	3%
Remaining amount	4%

Table 2. ABSD

Based on purchase price	Rate
SC ¹ buying first residential property	NA
SC ¹ buying second residential property	12%
SC ¹ buying third and subsequent residential property	15%

SC¹ denotes Singapore Citizens

(b) Calculate the **total** Buyer's Stamp Duty paid by Mr and Mrs Tan. [4]

Mr and Mrs Tan made a 20% down-payment based on the amount paid for the unit obtained in (a). For the remaining amount, which exclude the total Buyer's Stamp Duty, they had decided to sign up either for a 20-years Home Loan plan from CBCO Bank or a 30-years Home Loan plan from BSOP Bank.

(c) Determine which bank they should sign up if they can only afford a monthly instalment of not more than \$6000. Support you answer with appropriate workings. [5]

Simple Interest Rate for CBCO Bank

Loan period: 20 years

1 st year:	2 nd Year:
2.18% p.a.	2.18% p.a.
Thereafter: 2.68% p.a.	

Simple Interest Rate for BSOP Bank

Loan period: 30 years

1 st year:	2 nd Year:
1.95% p.a.	1.95% p.a.
Thereafter: 2.15% p.a.	

*** End of Paper ***

Answer keys for 2018 NCHS Prelim Exam 2_E.Maths Paper 2

1a	$\frac{1}{140xy^9}$	7ai	$14 - 3r$
1b	$x \leq 5\frac{1}{17}$	7aii	$25 - 15r$
1ci	$\frac{3x}{(x-2)(2x-1)}$	7b	$(14 - 3r)^2 = (25 - 15r)^2 + (13 - 6r)^2$
1cii	$x = 1$	7c	$2\frac{1}{6}$ or $1\frac{2}{21}$
2ai	$p = -2$	7d	72.1 cm^2
2aii	$S = (-9, -10)$	8ai	In triangle CAB, $\tan C\hat{B}A = \frac{17}{24}$ $C\hat{B}A = 0.61630 \text{ rad}$ $D\hat{O}A = 2 \times 0.61630$ (angle at centre = $2 \times$ angle at circumference) $= 1.23 \text{ rad}$ (shown)
2b	WZ = WU (given) = XY (opp sides of llgram) UY (common length) $W\hat{U}Y = 180 - W\hat{U}Z$ (adj angles on a str. line) $X\hat{Y}U = 180 - W\hat{Z}U$ (int. angles) Since WZ = WU $\Rightarrow W\hat{Z}U = W\hat{U}Z$ Hence $W\hat{U}Y = X\hat{Y}U$ ΔWUY is congruent to ΔXYU (SAS)	8aii	14.8 cm
3ai	$1.09 \times 10^{-8} \text{ m}$	8aiii	47.3 cm^3
3aii	$9.98 \times 10^{-25} \text{ cm}^3$	8bi	$h = 9 \text{ cm}$, $l = 15 \text{ cm}$
3b	4 min	8bii	$1188\pi \text{ cm}^2$
3c	1.3889×10^{91}	9ai	For SK Sec, median = 65 kg For HG Sec, median = 58 kg
4ai	$-9q + 4p$	9aii	Generally, the students for SK Sec Sch are heavier compared to the students in HG Sec Sch because of the higher median. The mass of the students in HG Sec Sch is more consistent than that of SK Sec Sch.
4aii	$-3q + 12p$	9aiii	Disagree as there are more than 25% of the students from SK Sec Sch weigh more than 70 kg while there are less than 25% of the students from HG Sec Sch weigh more than 70 kg. Accept: There are more students in SK Sec Sch weigh more than 70 kg because it has a higher upper quartile than HG Sec Sch.
4b	$3p + \frac{9}{4}q$	9bia	$m = 105$
4c	1	9bib	$\frac{3}{632}$
5a	1.6	9biia	$a = 3$, $b = 12$
5c	Accept 0.2 to 0.4	9biib	99.75 cm ; $SD = 12.6 \text{ cm}$
5d	Accept -3.06 to -2.46 It represents the rate of change of mass with respect to day when $d = 2.5$.	10a	$\$1\ 635\ 033.60$
5e	$0.3 < d < 4.95$	10b	$\$246\ 205.38$
6ai	032.3°	10c	CBCO Bank Monthly instalment = $\$8316.87 > \6000
6aii	212.3°		BSOP Bank Monthly instalment = $\$5962.42 < \6000 Mr and
6aiii	99.0°		
6aiv	2640 km^2		
6b	12.0°		Mrs Tan should sign up with BSOP Bank as the monthly instalment is less than $\$6000$.

Name:

Register Number:

Class:

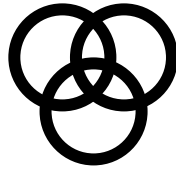

南僑中學

NAN CHIAU HIGH SCHOOL

**PRELIMINARY EXAMINATION (2) 2018
SECONDARY FOUR EXPRESS**

MATHEMATICS

4048/02

PAPER 2

10 September 2018, Monday

2 hours 30 minutes

SUGGESTED SOLUTIONS

Setter: Mrs Sim Hwee Mung

- 1**
- (a) Simplify $\frac{(2xy)^2}{35xy^7} \div \left(\frac{x^{-1}y^{-2}}{4}\right)^{-2}$, leaving your answer in positive index form. [2]
- (b) Solve the inequality $\frac{1}{4}x - \frac{3}{5}\left(x + \frac{1}{3}\right) \geq \frac{1}{2}(x - 9)$. [2]
- (c) (i) Express $\frac{2}{1-2x} + \frac{3(x-1)}{2x^2-5x+2} + \frac{1}{x-2}$ as a single fraction in its simplest form. [4]
- (ii) Hence solve the equation $\frac{2}{1-2x} + \frac{3(x-1)}{2x^2-5x+2} + \frac{1}{x-2} = \frac{3}{x-2}$. [2]

1	(a)	$\frac{(2xy)^2}{35xy^7} \div \left(\frac{x^{-1}y^{-2}}{4}\right)^{-2}$ $= \frac{4x^2y^2}{35xy^7} \div \left(\frac{4}{x^{-1}y^{-2}}\right)^2$ $= \frac{4x^2y^2}{35xy^7} \times \frac{x^{-2}y^{-4}}{16} \quad \text{[Able to remove both brackets][M1]}$ $= \frac{1}{140xy^9} \quad \text{[A1]}$	
	(b)	$\frac{1}{4}x - \frac{3}{5}\left(x + \frac{1}{3}\right) \geq \frac{1}{2}(x - 9)$ $\frac{1}{4}x - \frac{3}{5}x - \frac{1}{5} \geq \frac{1}{2}x - \frac{9}{2} \quad \text{[Able to expand all terms correctly][M1]}$ $-\frac{17}{20}x \geq -\frac{43}{10}$ $x \leq 5\frac{1}{17} \quad \text{[A1]}$	
	(c)(i)	$\frac{2}{1-2x} + \frac{3(x-1)}{2x^2-5x+2} + \frac{1}{x-2}$ $= \frac{-2}{2x-1} + \frac{3x-3}{(x-2)(2x-1)} + \frac{1}{x-2} \quad \text{[Able to factorise } 2x^2 - 5x + 2 \text{][M1]}$ $= \frac{-2(x-2)+3(x-1)+2x-1}{(x-2)(2x-1)} \quad \text{[Able to combine into common denominator][M1]}$ $= \frac{-2x+4+3x-3+2x-1}{(x-2)(2x-1)} \quad \text{[Able to expand correctly][M1]}$ $= \frac{3x}{(x-2)(2x-1)} \quad \text{[A1]}$	
	(c)(ii)	$\frac{2}{1-2x} + \frac{3(x-1)}{2x^2-5x+2} + \frac{1}{x-2} = \frac{3}{x-2}$ $\frac{3x}{(x-2)(2x-1)} = \frac{3}{x-2}, x \neq 2 \quad \text{[M1]}$ $\frac{3x}{2x-1} = 3$ $6x - 3 = 3x$ $3x = 3$ $x = 1 \quad \text{[A1]}$	[10]

- 2 (a) $PQRS$ is a parallelogram in which the coordinates of P and Q are $(p, 4)$ and $(7, 11)$ respectively. The line $9y + 27 - 7x = 0$ cuts the y -axis at R and is parallel to the line PQ .

Find

- (i) the value of p , [3]
(ii) the coordinates of S by **vector method**. [3]

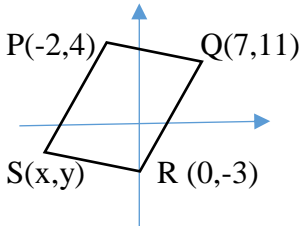
(a)(i)	$9y = 7x - 27$ $y = \frac{7}{9}x - 3$ <p>Gradient of the line = $\frac{7}{9}$</p> <p>Gradient of $PQ = \frac{7}{9}$ (parallel lines) [M1]</p> $m_{PQ} = \frac{11-4}{7-p}$ $\frac{11-4}{7-p} = \frac{7}{9} \quad [\text{M1}]$ $7 - p = 9$ $p = -2 \quad [\text{A1}]$	[9]
(a)(ii)	 <p>$\overrightarrow{OP} = \begin{pmatrix} -2 \\ 4 \end{pmatrix}, \overrightarrow{OQ} = \begin{pmatrix} 7 \\ 11 \end{pmatrix},$ $\overrightarrow{OS} = \begin{pmatrix} x \\ y \end{pmatrix}, \overrightarrow{OR} = \begin{pmatrix} 0 \\ -3 \end{pmatrix}$</p> <div style="border: 1px solid black; padding: 5px; display: inline-block;">Accept $\overrightarrow{SR} = \overrightarrow{PQ}$</div> <p>By vector method, $\overrightarrow{PS} = \overrightarrow{QR}$ [Concept of equal vectors][M1]</p> $-\begin{pmatrix} -2 \\ 4 \end{pmatrix} + \begin{pmatrix} x \\ y \end{pmatrix} = -\begin{pmatrix} 7 \\ 11 \end{pmatrix} + \begin{pmatrix} 0 \\ -3 \end{pmatrix} \quad [\text{M1}]$ $\begin{pmatrix} x \\ y \end{pmatrix} = \begin{pmatrix} -7 \\ -14 \end{pmatrix} + \begin{pmatrix} -2 \\ 4 \end{pmatrix}$ $= \begin{pmatrix} -9 \\ -10 \end{pmatrix}$ <p>$S = (-9, -10)$ [A1]</p>	

- (b) In the diagram, $WXYZ$ is a parallelogram and U is a point on ZY such that $WZ = WU$. The lines WY and UX intersect at V .

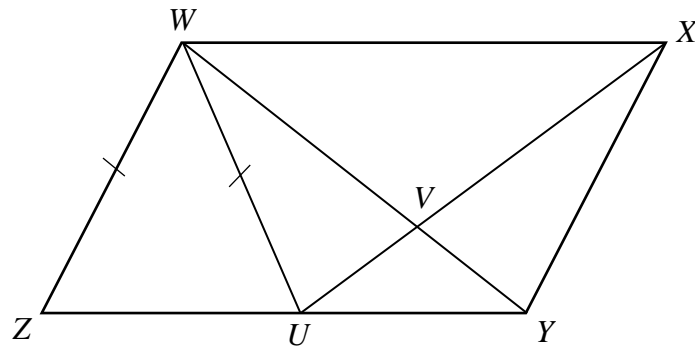

Prove that $\triangle WUY$ is congruent to $\triangle XYU$.

[3]

(b)	$WZ = WU$ (given) $= XY$ (opp sides of \parallel gram) UY (common length)	}	Prove 2 pairs of equal sides [M1]	
	$\widehat{WUY} = 180 - \widehat{WUZ}$ (adj angles on a str. line) $\widehat{XYU} = 180 - \widehat{WZU}$ (int. angles) Since $WZ = WU$ $\Rightarrow \widehat{WZU} = \widehat{WUZ}$ Hence $\widehat{WUY} = \widehat{XYU}$	}	Prove included angle [M1]	
	$\triangle WUY$ is congruent to $\triangle XYU$ (SAS) [A1]			

- 3 (a)** The radius of a particular spherical cell is approximately 6.2×10^{-11} metre.
- (i)** 88 of these spherical cells are arranged to form a straight line such that each cell touches one another without overlapping. Calculate the length, in metre, of the straight line formed. Give your answer in standard form. [1]
- (ii)** Calculate the volume of a spherical cell, in cubic centimetre. Give your answer in standard form correct to 2 decimal places. [1]
- (b)** The planet Mercury is approximately 77 billion metre from the Earth. Given that radio waves travel at a speed of 3×10^8 m/s, find the time taken for radio waves to travel from the Earth to Mercury, giving your answer to the nearest minutes. [2]
- (c)** The word ‘Googol’ is defined as 1×10^{100} . If a man has ten ‘Googol’ cents and a Boeing 737 aircraft costs \$72 million, how many such aircrafts can he buy? Give your answer in standard form correct to 5 significant figures. [3]

(a)(i)	$\text{Diameter} = 2 \times 6.2 \times 10^{-11}$ $\text{Length} = 88 \times 2 \times 6.2 \times 10^{-11}$ $= 1.09 \times 10^{-8} \text{ m [B1]}$	
(a)(ii)	$\text{Volume} = \frac{4}{3} \pi \times (6.2 \times 10^{-9})^3 \quad \text{Note: } r = 6.2 \times 10^{-11} \text{ m} = 6.2 \times 10^{-9} \text{ cm}$ $= 9.98 \times 10^{-25} \text{ cm}^3 \text{ (2dp) [B1]}$	
(b)	$t = \frac{77 \times 10^9}{3 \times 10^8} \text{ [M1]}$ $= 256 \frac{2}{3} \text{ s}$ $= 4 \text{ min (nearest min) [A1]}$	
(c)	$\text{ten 'Googol' cents} = \$ \frac{10 \times 1 \times 10^{100}}{100}$ $= \$10^{99} \text{ [Change to $][M1]}$ $\text{No of aircrafts} = \frac{10^{99}}{72 \times 10^6} \text{ [M1]}$ $= 1.3889 \times 10^{91} \text{ [A1]}$	[7]

- 4 In the diagram, $\overrightarrow{OA} = 12\mathbf{p}$ and $\overrightarrow{OB} = 9\mathbf{q}$.
It is given that $3DB = 2OB$ and $OA = 3OC$.

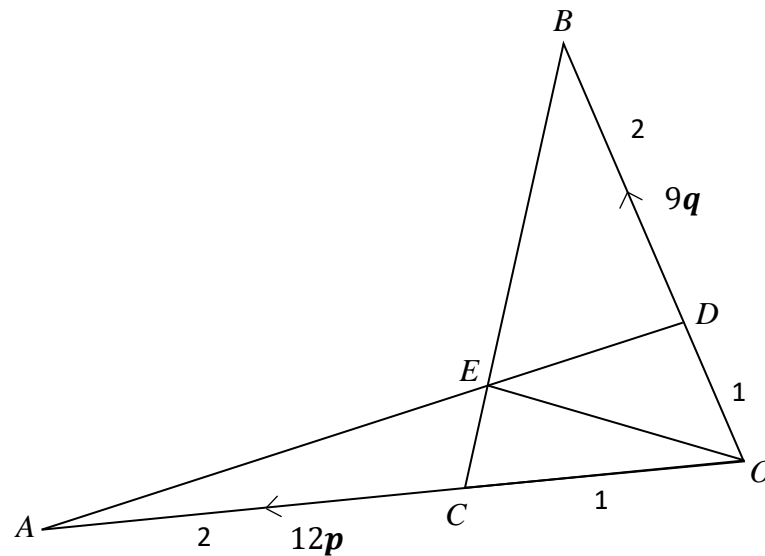

- (a) Express, as simply as possible, in terms of \mathbf{p} and \mathbf{q} ,
- (i) \overrightarrow{BC} , [2]
- (ii) \overrightarrow{DA} . [2]
- (b) Given that $\frac{\text{area of triangle } ODE}{\text{area of triangle } ODA} = \frac{1}{4}$, find \overrightarrow{OE} in terms of \mathbf{p} and \mathbf{q} . [2]
- (c) Find the value of $\frac{\text{area of triangle } BDE}{\text{area of quadrilateral } EDOC}$. [2]

(a)(i)	$\begin{aligned}\overrightarrow{BC} &= \overrightarrow{BO} + \overrightarrow{OC} \\ &= -9\mathbf{q} + \frac{1}{3}\overrightarrow{OA} \\ &= -9\mathbf{q} + 4\mathbf{p} \quad [\text{B1}]\end{aligned}$	
(a)(ii)	$\begin{aligned}\overrightarrow{DA} &= \overrightarrow{DO} + \overrightarrow{OA} \\ &= \frac{1}{3}\overrightarrow{BO} + 12\mathbf{p} \quad [\text{M1}] \\ &= -3\mathbf{q} + 12\mathbf{p} \quad [\text{A1}]\end{aligned}$	
(b)	$\begin{aligned}\frac{\text{area of triangle } ODE}{\text{area of triangle } ODA} &= \frac{1}{4} \\ \frac{0.5 \times ED \times h}{0.5 \times AD \times h} &= \frac{1}{4} \quad [\text{Shared same perpendicular height}][\text{M1}] \\ \frac{ED}{AD} &= \frac{1}{4} \\ \overrightarrow{OE} &= \overrightarrow{OA} + \overrightarrow{AE} \\ &= 12\mathbf{p} + \frac{3}{4}\overrightarrow{AD} \\ &= 12\mathbf{p} + \frac{3}{4}(3\mathbf{q} - 12\mathbf{p}) \quad [\text{M1}] \\ &= 3\mathbf{p} + \frac{9}{4}\mathbf{q} \quad [\text{A1}]\end{aligned}$	[8]

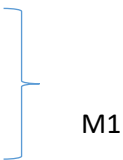
(c)	$\frac{\text{area of triangle } ODE}{\text{area of triangle } DEB} = \frac{OD}{DB} = \frac{1}{2}$ $\frac{\text{area of triangle } AEC}{\text{area of triangle } OEC} = \frac{AC}{OC} = \frac{2}{1}$	
	<p>Triangle ODE: Triangle DEB: Triangle AEC : Triangle OEC = 1 : 2 : 2 : 1</p> $\frac{\text{area of triangle } BDE}{\text{area of quadrilateral } EDOC}$ $= \frac{2}{2}$ $= 1 \quad [A1]$	

5 Answer the whole of this question on a sheet of graph paper.

A radioactive substance decays such that its mass, m grams, after d days is given by the equation $m = 43(3)^{-d}$.

The table below shows record of the mass, m grams of the substance, corrected to 1 decimal place, after d days.

d (days)	0	1	2	3	4	5	6
m (grams)	43	14.3	4.8	p	0.5	0.2	0.1

- (a) Find the value of p . [1]
- (b) Using a horizontal scale of 2 cm to represent 1 day and a vertical scale of 2 cm to represent 5 grams, draw the graph of $m = 43(3)^{-d}$ for $0 \leq d \leq 6$. [3]
- (c) Use your graph to estimate the value of d when the mass of substance is reduced to 65% of its original mass. [1]
- (d) By drawing a tangent, find the gradient of the curve at the point when $d = 2.5$.
State briefly what this gradient represents. [3]
- (e) Using your graph, find the range of d for $86(3)^{-d} + 12d < 60$. [2]
-

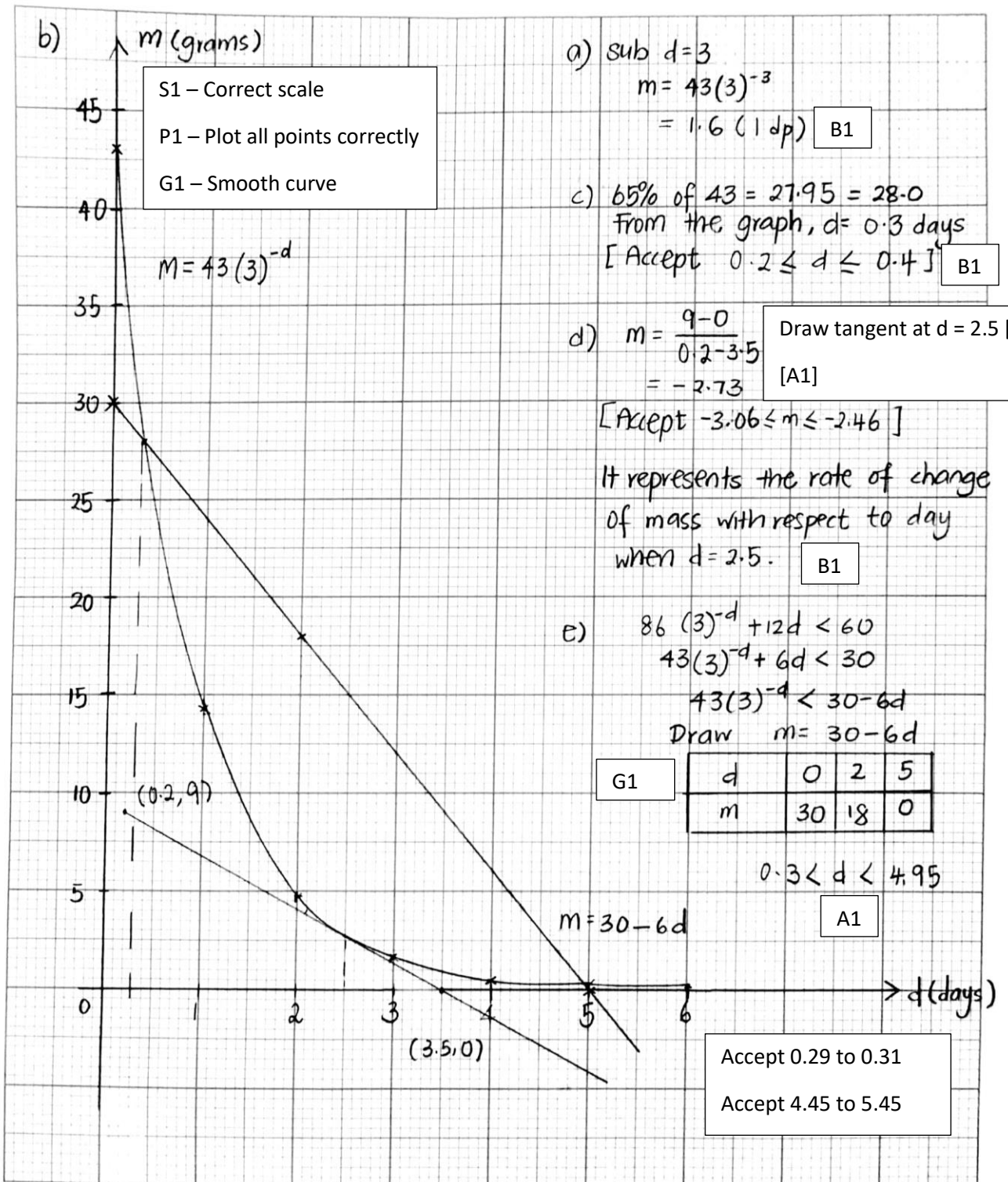

20 cm x 24 cm

[10]

- 6 PQR represents a triangular plot of land on horizontal ground.
 $PQ = 50$ km, $QR = 107$ km and $PR = 125$ km.
 R is due east of P .

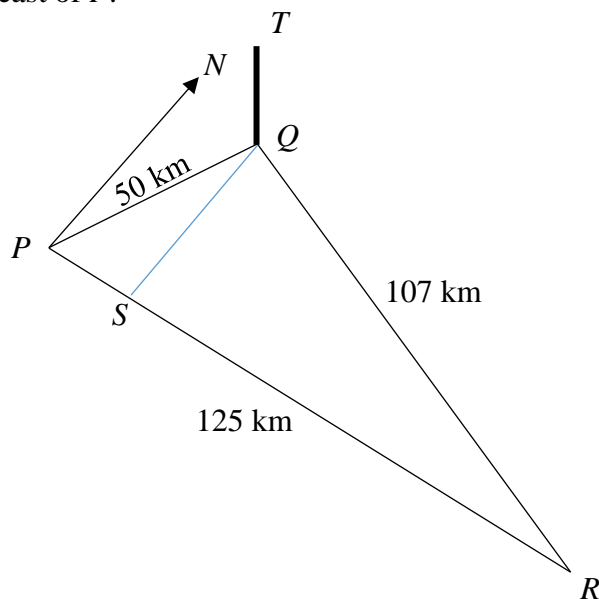

- (a) Calculate
- (i) the bearing of Q from P , [3]
 - (ii) the bearing of P from Q , [2]
 - (iii) the obtuse angle PQR , [2]
 - (iv) the area of the triangular plot of land PQR . [2]
- (b) A vertical pole of height 9 km is erected at Q . Calculate the greatest angle of elevation of the top of the pole from a point S along PR . [3]

(a)(i)	$\cos \widehat{PQR} = \frac{125^2 + 50^2 - 107^2}{(2)(125)(50)} \quad [\text{M1}]$ $\widehat{PQR} = 57.718$ Bearing of Q from P $= 90 - 57.718 \quad [\text{M1}]$ $= 32.3^\circ \text{ (1dp)} \quad [\text{A1}]$	[12]
(a)(ii)	Bearing of P from Q $= 360 - (180 - 32.282) \quad [\text{M1}]$ $= 212.3^\circ \text{ (1dp)} \quad [\text{A1}]$	
(a)(iii)	$\frac{\sin \widehat{PQR}}{125} = \frac{\sin 57.718}{107} \quad [\text{M1}]$ $\widehat{PQR} = 80.987^\circ \text{ (rejected) or } \widehat{PQR} = 99.013^\circ$ $\text{obtuse } \widehat{PQR} = 99.0^\circ \quad [\text{A1}]$ <p>or</p> $\cos \widehat{PQR} = \frac{107^2 + 50^2 - 125^2}{(2)(107)(50)} \quad [\text{M1}]$ $\text{obtuse } \widehat{PQR} = 99.0^\circ \quad [\text{A1}]$	

(a)(iv)	Area of the triangular plot of land PQR $= \frac{1}{2}(125)(50)\sin 57.718$ [M1] $= 2640 \text{ km}^2$ [A1]
(b)	In triangle PQS, $\sin 57.718 = \frac{d}{50}$ [M1] $d = 42.271$ In triangle PQT, $\tan e = \frac{9}{42.271}$ [M1] $e = 12.0^\circ$ [A1]

- 7 In the diagram, the circle C_1 with centre X has a radius $(3r + 1)$ cm, where r is a constant. Two identical semicircles, S_1 and S_2 with centre at Y and Z respectively, have a radius $(13 - 6r)$ cm.

Another semicircle, S_3 with centre O has a diameter AB .

C_1 touches S_1 and S_2 at P and Q respectively while S_1 and S_2 touches one another at O .

S_3 touches C_1 , S_1 and S_2 at R , A and B respectively.

$AYOZB$ is a straight line.

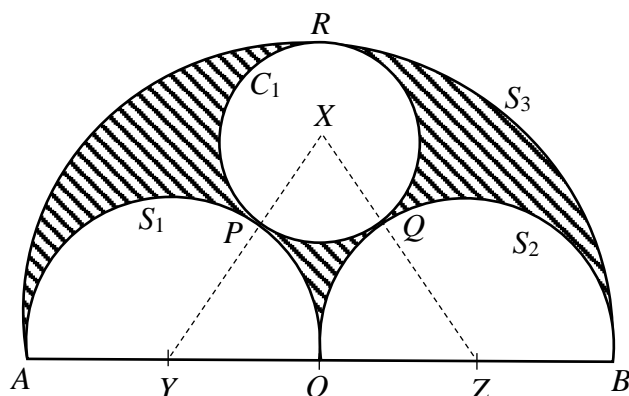

- (a) Write down an expression, in its simplest form and in terms of r , for
- (i) XZ , [1]
- (ii) XO . [2]
- (b) Hence, form an equation in terms of r and show that it reduces to $126r^2 - 411r + 299 = 0$. [3]
- (c) Solve the equation $126r^2 - 411r + 299 = 0$. [2]
- (d) Hence, find the area of the shaded region. [3]

(a)(i)	$XZ = XQ + QZ$ $= 3r + 1 + 13 - 6r$ $= 14 - 3r \text{ [B1]}$	
(a)(ii)	$XO = 2(13 - 6r) - (3r + 1) \text{ [M1]}$ $= 25 - 15r \text{ [A1]}$	
(b)	$XZ^2 = XO^2 + OZ^2$ $(14 - 3r)^2 = (25 - 15r)^2 + (13 - 6r)^2 \text{ [M1]}$ $196 - 84r + 9r^2 = 625 - 750r + 225r^2 + 169 - 156r + 36r^2 \text{ [M1]}$ $252r^2 - 822r + 598 = 0 \text{ [A1]}$ $126r^2 - 411r + 299 = 0 \text{ (shown)}$	
(c)	$r = \frac{411 \pm \sqrt{(-411)^2 - 4(126)(299)}}{2(126)} \text{ [M1]}$ $= 2\frac{1}{6} \text{ or } 1\frac{2}{21} \text{ [A1]}$	
(d)	<p>If $r = 2\frac{1}{6}$, then $XO < 0$.</p> <p>Hence $r = 1\frac{2}{21}$</p>	[11]

	<p>Area of the shaded region</p> $= \frac{1}{2} \pi (26 - 12 \left(1 \frac{2}{21}\right))^2 - \pi \left(3 \left(1 \frac{2}{21}\right) + 1\right)^2 - \pi (13 - 6 \left(1 \frac{2}{21}\right))^2$ <p>[M1 - Area of S3][M1 - correct unshaded area]</p> $= 72.1 \text{ cm}^2$ <p>[A1]</p>	
--	---	--

- 8 (a) The diagram shows a circle with centre O and radius of 12 cm. AB is the diameter of the circle and AC is a tangent to the circle at A with $AC = 17$ cm. The circle intersects the line BC at D .

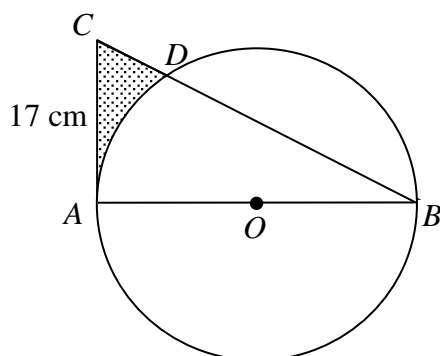

- (i) Show that angle $DOA = 1.23$ radians. [2]

Calculate

- (ii) the length of minor arc AD , [1]
 (iii) the area of the shaded region. [3]

- (b) Diagram I shows an open container which is made up of a cylinder and a cone. The cylinder has radius r cm and height 30 cm. The cone has base radius r cm and slant height l cm. The container is fully filled with water.

Diagram II shows a spherical object in which half of it is immersed into the container and some water is displaced. The radius of the sphere is the same as the radius of the cylinder. Assume the thickness of the container and the spherical object are negligible.

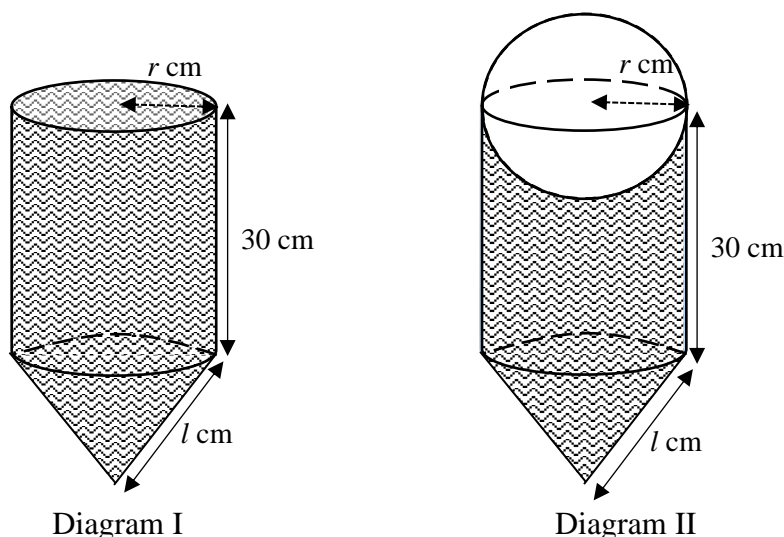

Given that the volume of the water displaced is 1152π cm³ and the volume of the water left in the container is 3600π cm³, find

- (i) the value of r and of l , [4]
 (ii) the total internal area of the container and the sphere that is in contact with water, leaving your answer in terms of π . [2]

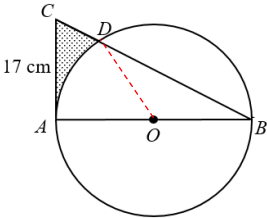
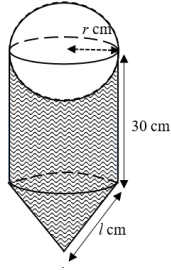
	(a)(i)	 <p>In triangle CAB, $\tan \hat{CBA} = \frac{17}{24}$ [M1] $\hat{CBA} = 0.61630 \text{ rad}$</p> <p>$\hat{DOA} = 2 \times 0.61630$ (angle at centre = $2 \times$ angle at circumference) $= 1.2326$ $= 1.23 \text{ rad}$ (shown) [A1]</p>	
	(a)(ii)	<p>length of minor arc AD $= 12 (1.2326)$ $= 14.8 \text{ cm}$ [B1]</p>	
	(a)(iii)	<p>Area of the shaded region (Join OD) $= \frac{1}{2}(17)(24) - \frac{1}{2}(12)^2(1.2326) - \frac{1}{2}(12)^2 \sin(\pi - 1.2326)$ [M1- Sector area][M1-area of triangle] $= 204 - 88.747 - 67.922$ $= 47.3 \text{ cm}^3$ [A1]</p>	
	(b)(i)	<p>Vol of water displaced = 1152π $\frac{1}{2} \times \frac{4}{3} \pi (r)^3 = 1152\pi$ [M1] $r^3 = 1728$ $r = 12 \text{ cm}$ [A1]</p> <p>Total volume $= 1152\pi + 3600\pi$ $= 4752\pi$</p> <p>$\pi(12)^2(30) + \frac{1}{3}\pi(12)^2h = 4752\pi$ [M1] $48h = 432$ $h = 9 \text{ cm}$</p> <p>By Pythagoras' Theorem, $l^2 = 9^2 + 12^2$ $l = 15 \text{ cm}$ [A1]</p>	
	(b)(ii)	<p>Internal area $= \pi(12)(15) + 2\pi(12)(30) + 2\pi(12)^2$ [M1] $= 1188\pi \text{ cm}^2$ [A1]</p>	[12]

- 9 (a) The following box-and-whisker diagrams show the distribution of the mass of 300 students from each school, SK Secondary School and HG Secondary School respectively.

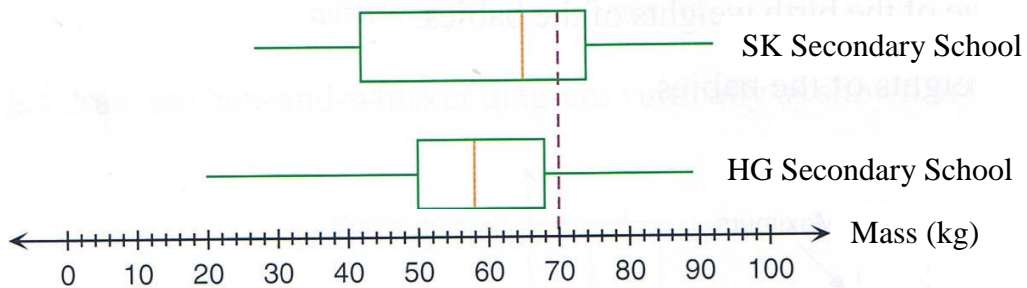

- (i) What is the median mass for each school? [1]
- (ii) Compare the mass of the students from SK Secondary School and HG Secondary School in two ways. [2]
- (iii) Mary commented that there are more students in HG Secondary School than SK Secondary School who weigh more than or equal to 70 kg. Do you agree with Mary? Support with a reason. [1]

(i)	For SK Sec, median = 65 kg For HG Sec, median = 58 kg Both correct [B1]	
(ii)	Generally, the students for SK Sec Sch are heavier compared to the students in HG Sec Sch because of the higher median. [B1] For SK, IQR= 32 kg; For HG, IQR = 18 kg The mass of the students in HG Sec Sch is more consistent than that of SK Sec Sch because of smaller interquartile range. [B1]	
(iii)	Disagree as there are more than 25% of the students from SK Sec Sch weigh more than 70 kg while there are less than 25% of the students from HG Sec Sch weigh more than 70 kg. [B1] Accept: There are more students in SK Sec Sch weigh more than 70 kg because it has a higher upper quartile than HG Sec Sch.	[4]

(b) The cumulative frequency curve shows the height distribution of 80 plants.

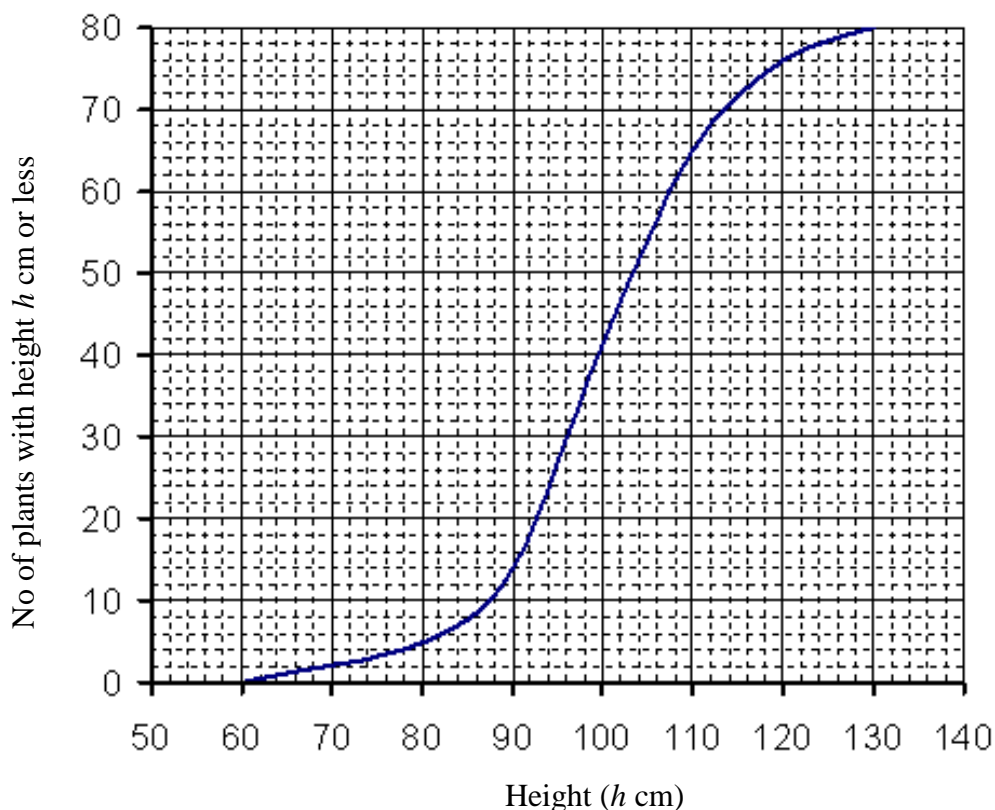

- (i) Use the graph to find
- (a) the value of m , if 32.5% of the plants have heights more than m cm, [2]
 - (b) the probability that two plants chosen will each has a height of more than 118 cm. [2]

(ii) (a) The height distribution of the 80 plants was also recorded in the following frequency table. Find the value of a and of b .

Height (h cm)	Number of plants
$60 < h \leq 70$	2
$70 < h \leq 80$	a
$80 < h \leq 90$	9
$90 < h \leq 100$	27
$100 < h \leq 110$	23
$110 < h \leq 120$	b
$120 < h \leq 130$	4

[1]

- (b) Hence find the mean and the standard deviation of the height of the 80 plants. [2]

		(bi)	(a)	No of plants less than or equal to m cm = 67.5% of 80 = 54 plants [B1] m = 105 [A1]	[7]
		(bi)	(b)	$\frac{6}{80} \times \frac{5}{79}$ [M1] $= \frac{3}{632}$ [A1]	
		(bii)	(a)	a = 3, b = 12 Both correct [B1]	
		(bii)	(b)	Mean = 99.75 cm [B1] Standard deviation = 12.6 cm [B1]	

- 10 Mr and Mrs Tan bought a 3-bedroom unit at a newly launched condominium project at Serangoon. The unit has a floor area of 1152 square foot (sqft). The selling price for the unit is at \$1494 per sqft. The developer gives a 5% early bird discount to all buyers.

- (a) Calculate the price that they paid for the unit. [1]

Mr and Mrs Tan are both Singapore citizens and they also owned a HDB 5-room flat and they do not have any intention of selling their flat. As such, they will have to pay Additional Buyer's Stamp Duty (ABSD) to the government on top of the Buyer's Stamp Duty (BSD). Table 1 shows the BSD rate and Table 2 shows the ABSD rate.

Table 1. BSD

Based on purchase price	Rate
First \$180 000	1%
Next \$180 000	2%
Next \$640 000	3%
Remaining amount	4%

Table 2. ABSD

Based on purchase price	Rate
SC ¹ buying first residential property	NA
SC ¹ buying second residential property	12%
SC ¹ buying third and subsequent residential property	15%

SC¹ denotes Singapore Citizens

- (b) Calculate the **total** Buyer's Stamp Duty paid by Mr and Mrs Tan. [4]

Mr and Mrs Tan made a 20% down-payment based on the amount paid for the unit obtained in (a). For the remaining amount, which exclude the total Buyer's Stamp Duty, they had decided to sign up either for a 20-years Home Loan plan from CBCO Bank or a 30-years Home Loan plan from BSOP Bank.

- (c) Determine which bank they should sign up if they can only afford a monthly instalment of not more than \$6000. Support you answer with appropriate workings. [5]

Simple Interest Rate for CBCO Bank

Loan period: 20 years

1 st year:	2 nd Year:
2.18% p.a.	2.18% p.a.
Thereafter: 2.68% p.a.	

Simple Interest Rate for BSOP Bank

Loan period: 30 years

1 st year:	2 nd Year:
1.95% p.a.	1.95% p.a.
Thereafter: 2.15% p.a.	

	<p>(a) Amount paid $= 1152 \times 1494 \times 0.95$ $= \\$1\,635\,033.60$ [B1]</p>	
	<p>(b) BSD paid $= 0.01 \times 180\,000 + 0.02 \times 180\,000 + 0.03 \times 640\,000 + 0.04 \times 635\,033.60$ [M1 – First 1 mil][M1 – remaining amount] $= 50\,001.344$</p> <p>ABSD paid $= 0.12 \times 1\,635\,033.60$ [M1] $= 196\,204.032$</p> <p>Total stamp duty $= 50\,001.344 + 196\,204.032$ $= \\$246\,205.38$ [A1]</p>	
	<p>(c) Loan amount $= 0.8 \times 1\,635\,033.60$ [M1] $= \\$1\,308\,026.88$</p> <p><u>CBCO Bank</u> Interest $= 2.18\% \times 2 \times 1\,308\,026.88 + 2.68\% \times 18 \times 1\,308\,026.88$ [M1] $= 688\,022.1389$</p> <p>Monthly instalment $= (688\,022.1389 + 1\,308\,026.88) \div (20 \times 12)$ [M1 for either of the monthly instalments] $= \\$8316.87 > \\6000</p> <p><u>BSOP Bank</u> Interest $= 1.95\% \times 2 \times 1\,308\,026.88 + 2.15\% \times 28 \times 1\,308\,026.88$ [M1] $= 838\,445.2301$</p> <p>Monthly instalment $= (838\,445.2301 + 1\,308\,026.88) \div (30 \times 12)$ $= \\$5962.42 < \\6000</p> <p>Mr and Mrs Tan should sign up with BSOP Bank as the monthly instalment is less than \$6000. [A1]</p>	[10]

