

Visit

FREETESTPAPER.com

for more papers



Website: [freetestpaper.com](http://www.freetestpaper.com)



[Facebook.com/freetestpaper](https://www.facebook.com/freetestpaper)



[Twitter.com/freetestpaper](https://www.twitter.com/freetestpaper)

Class	Index Number	Candidate Name
-------	--------------	----------------



**ANG MO KIO SECONDARY SCHOOL
MID-YEAR EXAMINATION 2019
SECONDARY FOUR EXPRESS / FIVE NORMAL ACADEMIC**

MATHEMATICS
Paper 1

4048/01

Setter: Mrs Seah Kwan Chaet

Wednesday

15 May 2019

2 hours

Candidates answer on the Question Paper.

READ THESE INSTRUCTIONS FIRST

Write your name, index number and class on all the work you hand in.
Write in dark blue or black pen.
You may use a pencil for any diagrams or graphs.
Do not use staples, paper clips, glue or correction fluid.

Answer **all** questions.

If working is needed for any question it must be shown with the answer.

Omission of essential working will result in loss of marks.

The use of an approved scientific calculator is expected, where appropriate.

If the degree of accuracy is not specified in the question, and if the answer is not exact, give the answer to three significant figures. Give answers in degrees to one decimal place.

For π , use either your calculator value or 3.142, unless the question requires the answer in terms of π .

At the end of the examination, fasten all your work securely together.

The number of marks is given in brackets [] at the end of each question or part question.

The total of the marks for this paper is 80.

For Examiner's Use
80

This document consists of 17 printed pages and 1 blank page.

*Mathematical Formulae**Compound interest*

$$\text{Total amount} = P \left(1 + \frac{r}{100} \right)^n$$

Mensuration

$$\text{Curve surface area of a cone} = \pi r l$$

$$\text{Surface area of a sphere} = 4\pi r^2$$

$$\text{Volume of a cone} = \frac{1}{3} \pi r^2 h$$

$$\text{Volume of a sphere} = \frac{4}{3} \pi r^3$$

$$\text{Area of triangle } ABC = \frac{1}{2} ab \sin C$$

$$\text{Arc length} = r\theta, \text{ where } \theta \text{ is in radians}$$

$$\text{Sector Area} = \frac{1}{2} r^2 \theta, \text{ where } \theta \text{ is in radians}$$

Trigonometry

$$\frac{a}{\sin A} = \frac{b}{\sin B} = \frac{c}{\sin C}$$

$$a^2 = b^2 + c^2 - 2bc \cos A$$

Statistics

$$\text{Mean} = \frac{\sum fx}{\sum f}$$

$$\text{Standard deviation} = \sqrt{\frac{\sum fx^2}{\sum f} - \left(\frac{\sum fx}{\sum f} \right)^2}$$

- 1 (a) Simplify $x + 7 - x(2 - 3x)$.

Answer

[2]

- (b) Factorise completely $4ax + 12a - x - 3$.

Answer

[2]

- 2 The pie chart shows the sales for 4 different flavours of cookies.

Chocolate is the Most Popular Flavour

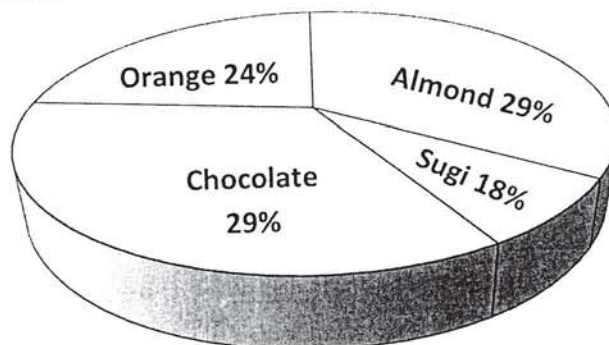

State one aspect of the graph that may be misleading and explain how this may lead to a misinterpretation of the graph.

Answer

[2]

- 3 (a) Write down the set notation for the set represented by the shaded region in the Venn diagram below.

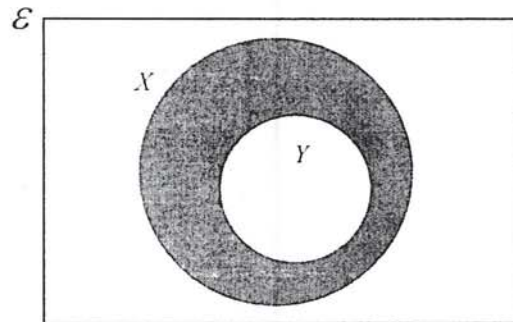

Answer

[1]

- (b) $\mathcal{E} = \{x : x \text{ is an integer, } 1 \leq x \leq 9\}$
 $A = \{x : x \text{ is an odd number}\}$
 $B = \{x : x \text{ is a factor of } 6\}$

- (i) Draw a Venn diagram in the box below to illustrate the above information.

Answer

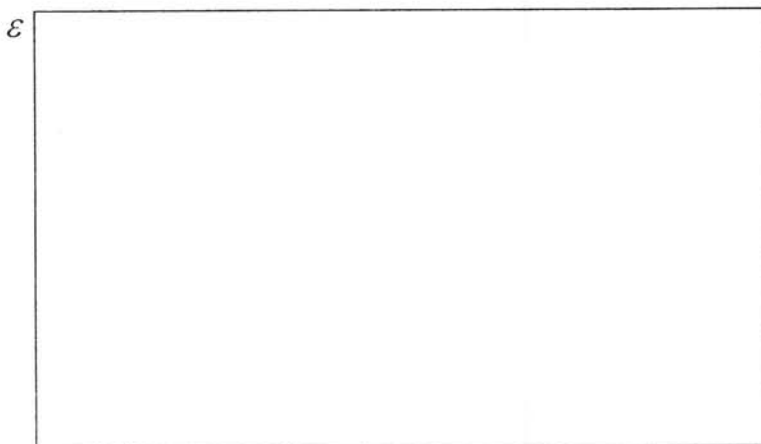

[1]

- (ii) List the elements in the set $(A \cup B)'$.

Answer

[1]

- 4 (a) Express $x^2 - 2x - 2$ in the form $p + (x + q)^2$.

Answer

[2]

- (b) Sketch the graph of $y = x^2 - 2x - 2$ on the axes below.
Indicate clearly the values where the graph crosses the x - and y - axes.

Answer

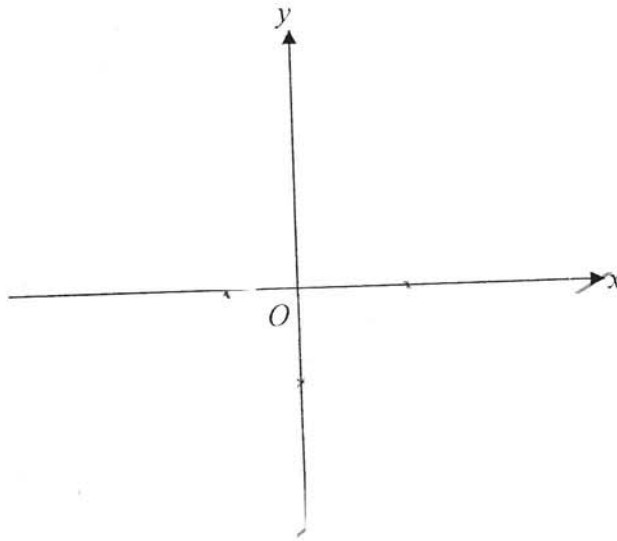

[2]

-
- 5 The exchange rate between Singapore dollars (\$) and Japanese Yen (¥) was $\$1 = ¥81.7339$. Mr Toshi bought a watch priced at \$1550. The shop charged 1.8% commission as he chose to pay in Japanese Yen using his credit card. What was the total cost of the watch in Japanese Yen?

Answer ¥

[2]

- 6 Write as a single fraction in its simplest form $\frac{4}{3-x} + \frac{1}{x^2-3x}$.

Answer

[2]

-
- 7 A map is drawn to a scale of 1 : 500 000.

- (a) The length of a runway at an airport is 0.6 cm on the map. Calculate the actual length of the runway in kilometres.

Answer

km [1]

- (b) The airport has an area of 5 km². Calculate the area, in square centimetres, of the airport on the map.

Answer

cm² [2]

- 8 The monthly telephone charges offered by a telecommunications company is obtained by adding a fixed charge of \$28 and the total usage for the month as shown below.

Usage Per Month	Rate (cents per minute)
First 5 hours	Free
Next 20 hours	3.5
Exceed 20 hours	10

If the total usage for the month of February was 31 hours, calculate the telephone charges for that month.

Answer \$

[2]

- 9 Two pails, X and Y , are geometrically similar. The volume of pail X is 512 cm^3 . Given that the base area of pail Y is four times the base area of pail X , find the volume of pail Y .



Pail X

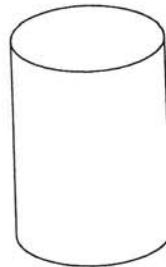

Pail Y

Answer

cm^3 [3]

- 10 The diagram below shows a triangle PQR with coordinates $P(0, 5)$ and $Q(7, 0)$. The area of the triangle is 28 cm^2 .

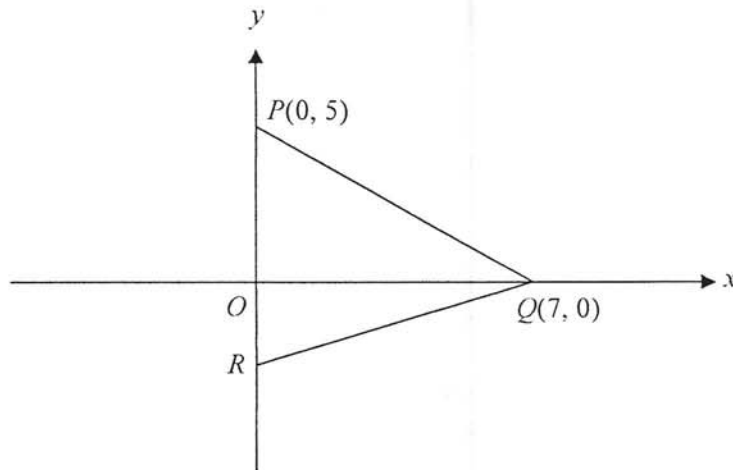

Find

- (a) the coordinates of R ,

Answer R (.....) [2]

- (b) the equation of the line QR .

Answer .. [2]

- 11 If the length of a rectangle is increased by 30% and its breadth is decreased by 20%, find the percentage change in its area.

Answer % [2]

12 Written as the product of its prime factors, $126 = 2 \times 3^2 \times 7$.

(a) Express 720 as a product of its prime factors.

Answer

[2]

(b) Find the largest integer which is a factor of both 126 and 720.

Answer

[1]

(c) Find the smallest possible value of m if $720m$ is both a perfect square and a perfect cube.

Answer $m =$

[1]

13 In the diagram below, $AB = 8$ cm, $BC = 9$ cm and $\angle BAC = 42^\circ$. Find $\angle ACB$.

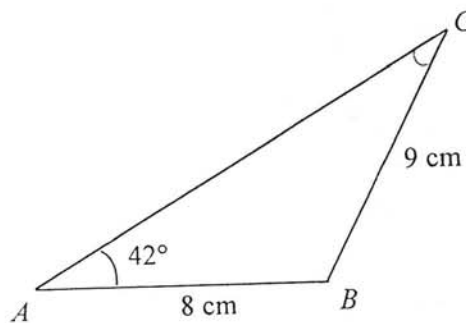

Answer

° [2]

- 14 The diagram below shows part of a circle ABC with centre O and radius 10 cm. The radius OC makes an angle of 1.2 radians with the radius OB . ACD is a sector with centre A and radius 16 cm.

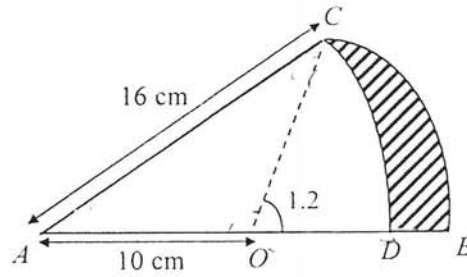

Find the area of the shaded region BCD .

Answer cm² [5]

- 15 The cumulative frequency curve shows the marks obtained by 200 pupils in a particular Science examination. The maximum mark is 80.

Cumulative Frequency

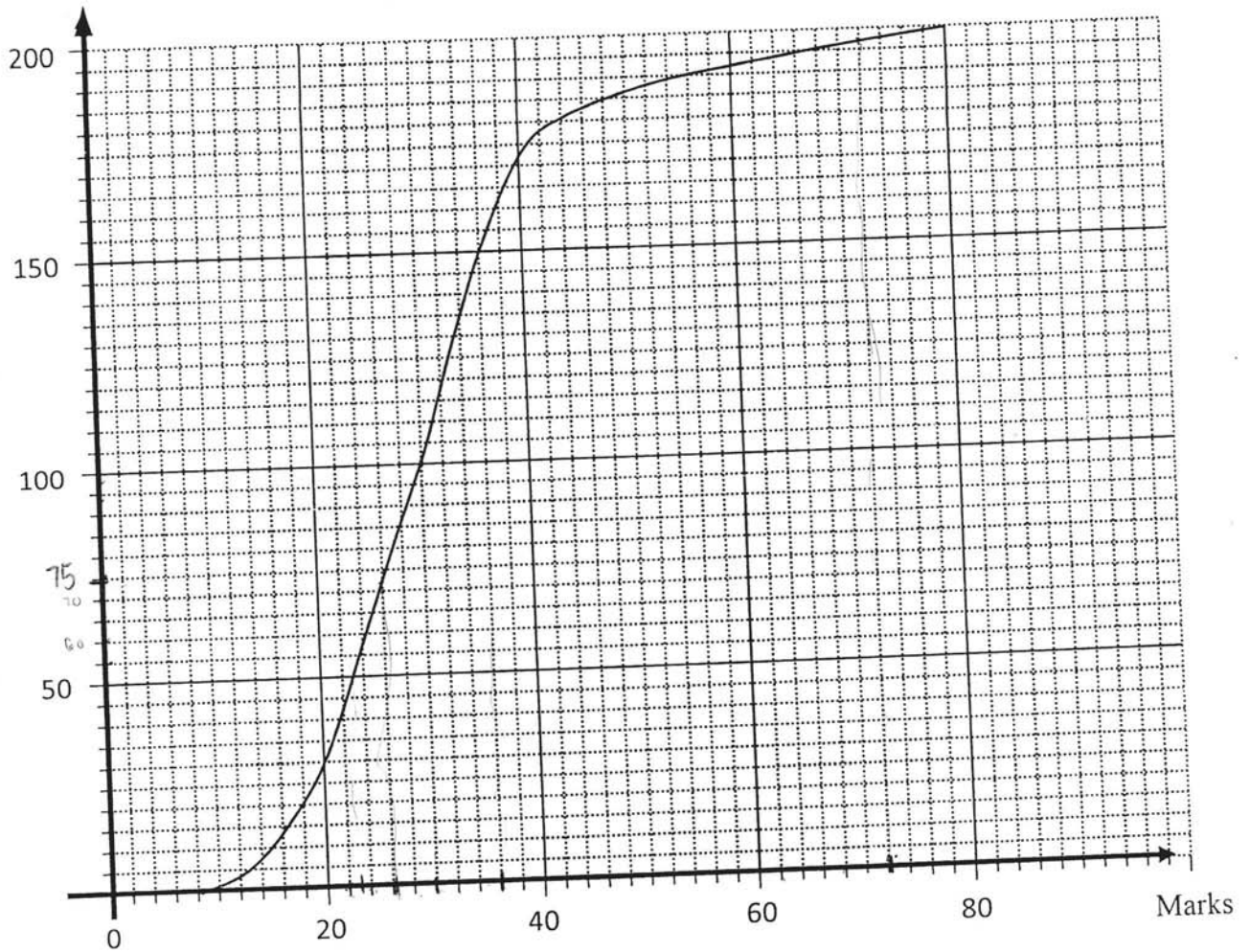

Find the

- (a) (i) median,

Answer

[1]

- (ii) interquartile range.

Answer

[2]

- (b) Find the passing mark if 36% of the pupils passed the examination.

Answer

[1]

16 The sum of a series of numbers is given below

$$S_n = 1 + 2 + 3 + \dots + n = \frac{n(n+1)}{2}.$$

(a) Find the value of S_{35} .

Answer

[1]

(b) Find the value of n given that $S_n = 1378$.

Answer

[2]

(c) If $T = 101 + 102 + 103 + \dots + 199$, find the value of T .

Answer

[2]

(d) Given the sum of even integers is $P = 2 + 4 + 6 + \dots + 100$, find the value of P .

Answer

[2]

(e) Using your answer in part (d), find the sum of all the odd integers between 0 and 100.

Answer

[1]

- 17 A drinks vending machine takes 50 cent coins and \$1 coins. A drink costs \$1.50. The probability that the machine will accept a particular 50 cent coin is 0.9 and that it will accept a particular \$1 coin is 0.85.

(a) What is the probability that the machine will not accept a particular 50 cent coin?

Answer

[1]

(b) John put one 50 cent coin and one \$1 coin into the machine. Calculate the probability that

(i) the machine will not accept both coins,

Answer

[1]

(ii) John will get a drink only when he inserts another \$1 coin.

Answer

[1]

(c) Peter only has three 50 cent coins. Calculate the probability that

(i) the machine will accept all three coins,

Answer

[1]

(ii) Peter will not get a drink.

Answer

[1]

- 18 $\vec{AB} = \begin{pmatrix} 4 \\ -5 \end{pmatrix}$, $\vec{BC} = \begin{pmatrix} -5 \\ 2 \end{pmatrix}$ and B is the point $(7, 0)$. Find

(a) $|\vec{AB}|$,

Answer

[1]

- (b) the coordinates of the point C .

Answer $C($

) [2]

- 19 The marks scored by 12 students from a Sec 4 class in a test are listed below.

72, 27, 38, 85, 54, 32, 76, 46, 68, 56, 64, 92.

The diagram below shows a box-and-whisker plot representing their results.

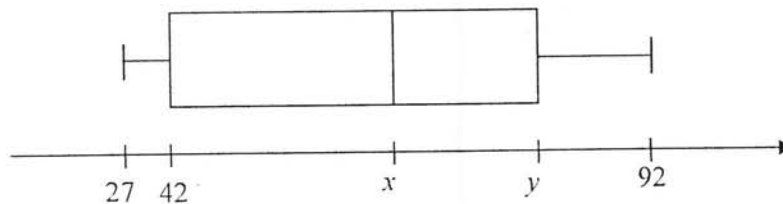

- (a) Find the value of x and of y .

Answer $x =$

$y =$

[2]

- (b) A new student later joined the group and sat for the same test. If the median mark remains unchanged, find the mark scored by the new student.

Answer

[1]

- 20 The diagram below shows a cone fitted inside a sphere. V is the vertex of the cone and O is the centre of the sphere. Given that the cone has a height of 10 cm and a base radius of 5 cm, find the radius of the sphere, R .

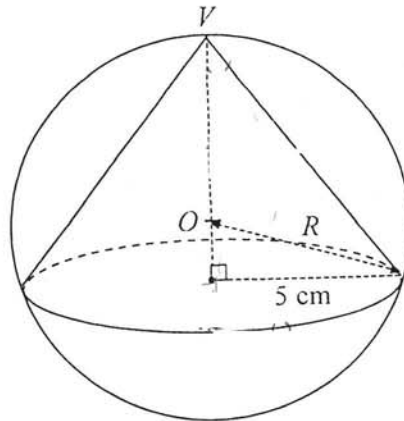

Answer

cm [3]

- 21 (a) Simplify each of the following, giving your answer as a positive index.

(i) $(x^{-3}y)^{-5}$

Answer

[1]

(ii) $\frac{18x^{\frac{1}{3}}}{4\sqrt{x}}$

Answer

[2]

- (b) Solve the equation $2^{5x-1} = 3^{5x-1}$.

Answer $x =$

[2]

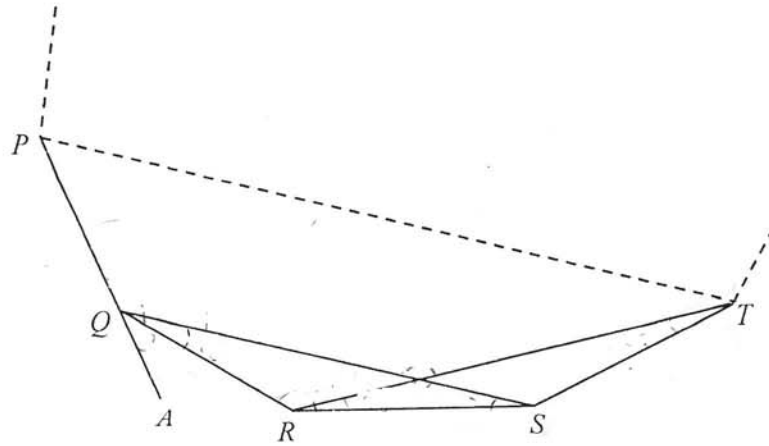

The diagram shows part of a regular n -sided polygon, $PQRST\dots$

(a) Explain why triangles QRS and TSR are congruent.

Answer

[2]

(b) It is given that angle $AQR = 30^\circ$. Find

(i) the value of n ,

Answer

[1]

(ii) angle RTS ,
 $\angle QRS$

Answer

[2]

(iii) angle QPT .

Answer

[2]

END OF PAPER

BLANK PAGE

Class	Index Number	Candidate Name
-------	--------------	----------------



ANG MO KIO SECONDARY SCHOOL
MID-YEAR EXAMINATION 2019
SECONDARY FOUR EXPRESS / FIVE NORMAL ACADEMIC

MATHEMATICS
Paper 2

4048/02

Setter: Mdm Kwa Leng Leng

Monday

13 May 2019

2 hours 30 minutes

Candidates answer on the Question Paper.
 Additional Materials: Graph Paper (1 sheet)

READ THESE INSTRUCTIONS FIRST

Write your name, index number and class on all the work you hand in.
 Write in dark blue or black pen.
 You may use an HB pencil for any diagrams or graphs.
 Do not use staples, paper clips, glue or correction fluid.

Answer **all** questions.

If working is needed for any question it must be shown with the answer.
 Omission of essential working will result in loss of marks.

The use of an approved scientific calculator is expected, where appropriate.

If the degree of accuracy is not specified in the question, and if the answer is not exact, give the answer to three significant figures. Give answers in degrees to one decimal place.

For π , use either your calculator value or 3.142, unless the question requires the answer in terms of π .

The number of marks is given in brackets [] at the end of each question or part question.
 The total of the marks for this paper is **100**.

For Examiner's Use
100

This document consists of **22** printed pages and **1** insert.

*Mathematical Formulae**Compound interest*

$$\text{Total amount} = P \left(1 + \frac{r}{100} \right)^n$$

Mensuration

$$\text{Curve surface area of a cone} = \pi r l$$

$$\text{Surface area of a sphere} = 4\pi r^2$$

$$\text{Volume of a cone} = \frac{1}{3} \pi r^2 h$$

$$\text{Volume of a sphere} = \frac{4}{3} \pi r^3$$

$$\text{Area of triangle } ABC = \frac{1}{2} ab \sin C$$

$$\text{Arc length} = r\theta, \text{ where } \theta \text{ is in radians}$$

$$\text{Sector Area} = \frac{1}{2} r^2 \theta, \text{ where } \theta \text{ is in radians}$$

Trigonometry

$$\frac{a}{\sin A} = \frac{b}{\sin B} = \frac{c}{\sin C}$$

$$a^2 = b^2 + c^2 - 2bc \cos A$$

Statistics

$$\text{Mean} = \frac{\sum fx}{\sum f}$$

$$\text{Standard deviation} = \sqrt{\frac{\sum fx^2}{\sum f} - \left(\frac{\sum fx}{\sum f} \right)^2}$$

1 (a) It is given that $y+z = \frac{4y-6z}{7x}$.

(i) Find x when $y=2$ and $z=-1$.

[1]

(ii) Express z in term of x and y .

[2]

(b) Solve the equation $\frac{2a+1}{3} + \frac{a-2}{4} = 2$.

[2]

(c) Solve these simultaneous equations.

$$4p + 3q = 2$$

$$5p - 4q = 49$$

[3]

(d) Simplify $\frac{4h^2 - 36}{4h^2 - 5h - 21}$.

[3]

2

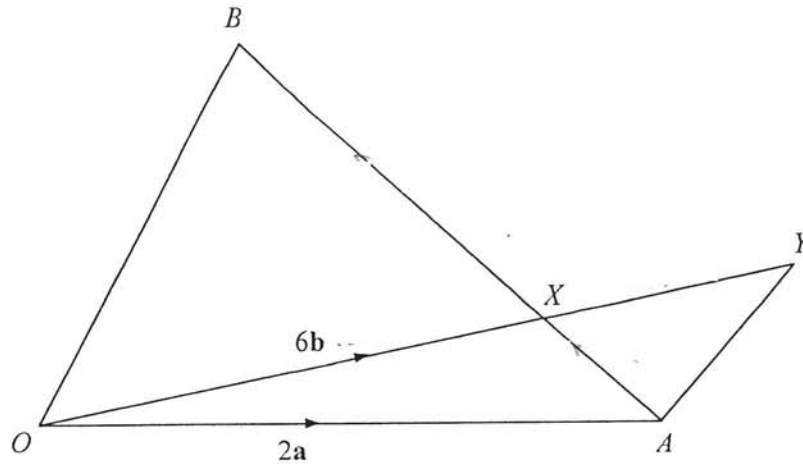

- (a) In $\triangle OAB$, the point X on AB is such that $AX : XB = 1 : 3$. OXY is a straight line and $XY = \frac{1}{4} OY$.

Given that $\vec{OA} = 2\mathbf{a}$, $\vec{OX} = 6\mathbf{b}$, write each of the following in terms of \mathbf{a} and \mathbf{b} . Give your answers in their simplest form.

(i) \vec{AX} , [1]

(ii) \vec{OB} , [2]

(iii) \vec{AY} . [2]

- (b) State 2 facts about \vec{AY} and \vec{OB} . [2]

- 3 Famous Factory produces pastries and delivers them to two outlets every day that each outlet is open. There are 3 deliveries for each day. The number of pastries supplied in a single delivery is given by the matrix \mathbf{P} .

	Outlet 1	Outlet 2	
$\mathbf{P} =$	$\left(\begin{array}{cc} 60 & 80 \\ 30 & 50 \\ 80 & 100 \end{array} \right)$		Chicken Pie
			Tuna Puff
			Cream Puff

- (a) Evaluate the matrix $\mathbf{D} = 3\mathbf{P}$. [1]

- (b) A chicken pie is sold at \$2. A tuna puff is sold at \$1.80. A cream puff is sold at \$1.40. Represent these prices in a 1×3 matrix \mathbf{C} . [1]

- (c) Evaluate the matrix $\mathbf{Q} = \mathbf{CD}$. [2]

- (d) State what the elements of \mathbf{Q} represent. [1]

- (e) In a particular month, Outlet 1 was opened for 22 days and Outlet 2 was opened for 30 days. Write down a 2×2 matrix \mathbf{E} such that the matrix $\mathbf{F} = \mathbf{QE}$, where the elements of \mathbf{F} represent the amount of money collected from selling all the pastries in each outlet in that month.

Hence evaluate \mathbf{F} .

[2]

- (f) There are two promotion schemes proposed. Scheme A is price reduction of 10% on all pastries and Scheme B is price reduction of 20% on chicken pies only. Supposing all pastries at each outlet are sold at the end of a day, calculate the daily amount of money collected at each outlet from the sale of pastries under each promotion schemes. Hence, propose the suitable scheme for each outlet.

[2]

- 4 $ABCD$ is a square with sides 12cm and BCE is a semi-circle with centre O . AF is a tangent to the semi-circle at point E and $BOCF$ is a straight line.

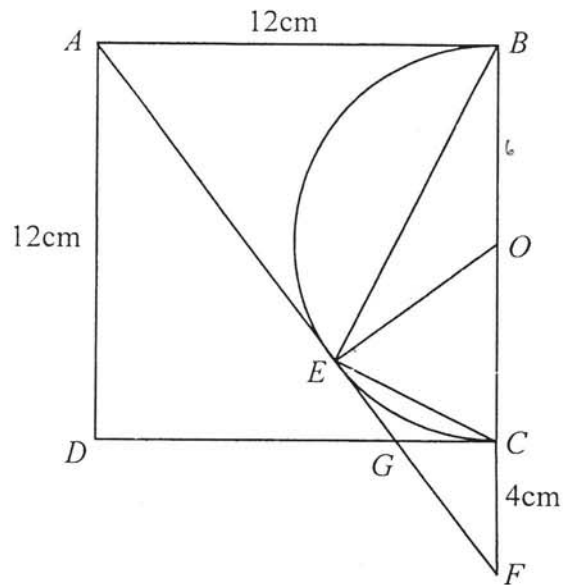

- (a) Name a triangle similar to $\triangle ADG$. [1]
- (b) Show that $\triangle OEF$ is similar to $\triangle ABF$. [2]

(c) Find the length of EF .

[2]

(d) Find the ratio

(i) $\frac{\text{Area of } \triangle EFC}{\text{Area of } \triangle ECB}$,

[1]

(ii) $\frac{\text{Area of } \triangle OEF}{\text{Area of quadrilateral } ABOE}$.

[2]

5 Xavier and Yves were running on a 400m track in Bishan Stadium. Both of them started from the same point. Xavier started running at a speed of x m/s. At the same time, Yves also started running in the opposite direction at speed of $(x+3)$ m/s and he met Xavier on the track again after t s.

(a) Write down two expressions that each represents the distance travelled by Xavier and Yves after t s. [2]

(b) Using the two expressions of distances in part (a), show that $t = \frac{400}{2x+3}$. [1]

(c) Zed started off together with the 2 boys and he ran in the same direction as Yves. However, he ran at a speed of $(x - 1)$ m/s. Find, in terms of x , the time taken when Xavier and Zed met each other on the track again. [1]

- (d) Given that Xavier met Zed 20 seconds after passing Yves, form an equation in terms of x and show that it simplifies to $4x^2 + 4x - 83 = 0$. [3]

- (e) Solve the equation $4x^2 + 4x - 83 = 0$. [3]

- (f) Find the time taken by Xavier to complete running one round around the track. [1]

- 6 The diagram shows a solid trapezoidal prism. The base $ABCD$ is on flat ground and $ABGH$, $BCFG$, $CDEF$ and $ADEH$ are vertical rectangular planes. $AB = 35\text{m}$, $BC = 23\text{m}$, $CD = 17\text{m}$, $AH = 8\text{m}$, $AD = 20\text{m}$, $\angle ABC = 42^\circ$ and AB is parallel to DC .

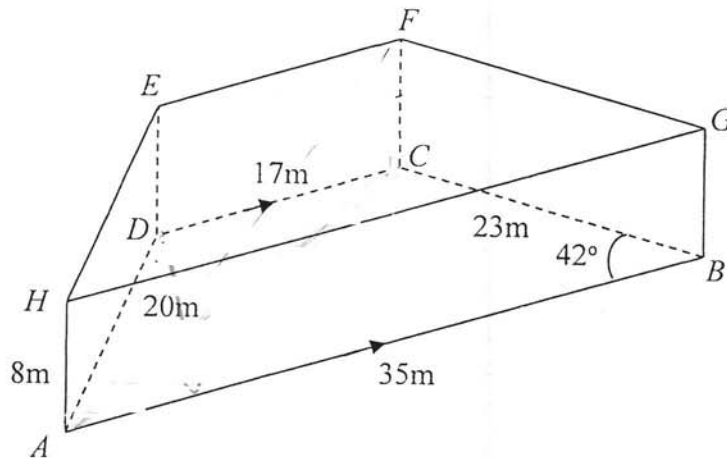

Calculate

- (a) the length of AC ,

[3]

- (b) the angle of depression of A from F ,

[2]

- (c) the area of triangle ABC ,

[2]

(d) the perpendicular distance from point D to the line AB ,

[2]

(e) the surface area of the prism.

[3]

- 7 (a) In the figure below, AB is a diameter of the circle with centre O . AZY and XYB are straight lines. $\angle BAZ = 47^\circ$ and $\angle BYZ = 23^\circ$.

Stating your reasons clearly, find $\angle BZX$.

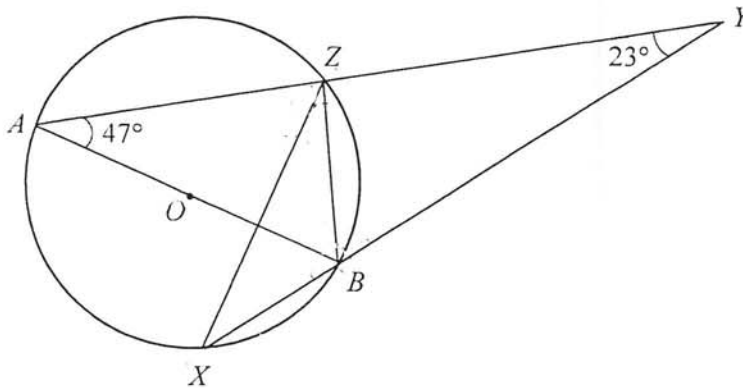

[3]

- (b) The above diagram shows two rhombuses $ABCD$ and $EFGC$. $\angle BFG = 114^\circ$ and $\angle DAE = 109^\circ$. Stating your reasons clearly, calculate

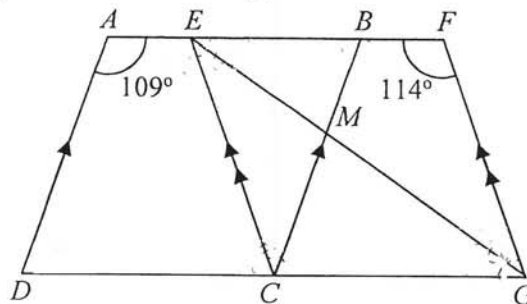

(i) $\angle FBC$,

[1]

(ii) $\angle FGE$,

[2]

(iii) $\angle EMB$.

[2]

- 8 (a) Dice A has the numbers 1, 2, 3 and 4 engraved on it while dice B has the numbers 2, 3, 5 and 7 engraved on it. They are rolled one after another and the sum of the two rolls is then recorded on a possibility diagram.

(i) Complete the possibility diagram.

[2]

		Dice A			
Dice B	+	1	2	3	4
	2		4	5	
	3	4	5		7
	5	6	7		9
	7		9	10	

(ii) Find the probability that both dice show odd numbers.

[1]

(iii) Find the probability that the sum of the two numbers is prime.

[1]

(iv) Find the probability that the sum of the two numbers is at most 9.

[1]

- 8 (b) A group of 23 basketball players were asked how many points they scored in a season of matches. The results are presented in the following stem-and-leaf diagram.

4	3	5	6	7	7	9
5	1	2	4	6	8	
6	0	3	4	6	7	8 9
7	1	1	2	3		
8	9					

Key: 4 | 3 means 43 points

- (i) Find the range. [1]

- (ii) Find the median score. [1]

- (iii) A special award is given to players who scored more than 75 points in a season. Find the percentage of players who attained this award. [1]

- (iv) A moderation has to be done and 2 points are to be added across all the scores.
Explain how the median score is affected by this moderation. [1]

- (v) Find the standard deviation of the scores. [2]

- (vi) The standard deviation of the scores of another group of players was 7.96 points.
Use this information to comment on one difference between the two groups.

[1]

- 9 The variables x and y are connected by the equation

$$y = 2x + \frac{18}{x^2}.$$

Some corresponding values of x and y are given in the following table.

X	1	1.5	2	3	4	5	6
Y	20	11	a	8	9.1	10.7	12.5

- (a) Find the value of a . [1]

- (b) **Draw the graph on the graph paper provided and staple it at the end of this question paper.**

Using a scale of 2 cm to 1 unit, draw a horizontal x -axis for $0 \leq x \leq 6$.

Using a scale of 1 cm to 1 unit, draw a vertical y -axis for $0 \leq y \leq 22$.

On your axes, plot the points given in the table and join them with a smooth curve. [3]

- (c) Use your graph to solve $2x + \frac{18}{x^2} = 12$ in the range $0 \leq x \leq 6$. [2]

- (d) By drawing a tangent, find the gradient of the graph at the point where $x = 1.5$. [2]

(e) On the same axes, draw the graph of $y = x + 10$ for $0 \leq x \leq 6$. [1]

(i) Write down the x -coordinate of the point where the two graphs intersect. [1]

(ii) Given that this value of x is a solution to the equation

$$x^3 + Ax^2 + Bx + 18 = 0,$$

find the value of A and the value of B . [2]

10 The Open Electricity Market is an initiative by the Energy Market Authority (EMA) that allows households to buy electricity from a retailer of their choice to benefit from their competitive pricing or continue to buy from SP Group at the regulated tariff rate, which is reviewed every quarter. There are two types of standard price plans:

- **Fixed Price Plans** are for consumers who prefer a constant electricity rate throughout the contract duration. The rate may be higher or lower than the regulated tariff rate during the contract duration.
- **Discount off the Regulated Tariff Plans** provide a fixed discount off the regulated tariff rate, but the electricity rates will change when the regulated tariff rates changes every quarter.

Jimmy is reviewing some price plans of two retailers. He stays in a private condominium and a part of his utilities bills is given below.

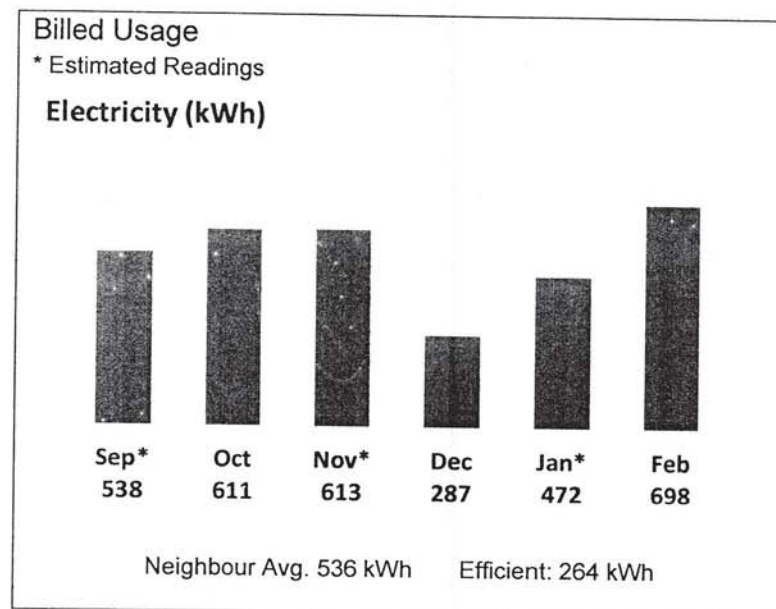

- (a) Calculate the mean value of the electricity usage over the 6 months. Explain why this mean may not be an appropriate average to assist Jimmy in reviewing his options. [2]

(b) **The fact sheets of two of the retailers are shown in the INSERT.**

(i) The electricity retailers charge a fee if you terminate the contract before its expiry date. If Jimmy signs a **12-Month Fixed Price Plan** contract with **Sembcorp Power Pte Ltd** starting on 1 January 2019 but considers to switch over to **iSwitch Pte Ltd** from 1 March 2019 onwards, calculate the early termination charge that he has to pay. [2]

(ii) Jimmy forgets to pay his bill for the electricity usage in the month of February 2019 before the payment due date in March. Considering a **12-Month Fixed Price Plan** contract, which company imposes a higher late payment charge? Justify your answer and show your calculations clearly. [2]

- (iii) By considering the period of 1 January to 28 February 2019, suggest the plan in **iSwitch Pte Ltd** that Jimmy should choose. Justify your suggestion and show your calculations clearly.

[4]

END OF PAPER

INSERT FOR QUESTION 10

The fact sheets of two of the retailers are shown below. All fees and charges stated in these fact sheets are inclusive of Goods and Services Tax (GST).

Name of retailer	iSwitch Pte Ltd	
Price Plan	'Chope' the Rate (12 Months)	Super Saver Discount (12 Months)
Electricity Rate	17.62 cents/kWh	22.80% off the regulated tariff
Late Payment Charge	1% of the outstanding amount per month	
Early Termination Charge	<ul style="list-style-type: none"> • \$100 if terminated within 3 days from sign-up • 30% of months left × average of latest 2 months bill if terminated after 3 days from sign-up 	

Name of retailer	Sembcorp Power Pte Ltd	
Price Plan	12-Month Fixed Price Plan	12-Month Discount off Regulated Tariff Plan
Electricity Rate	18.65 cents/kWh	20.50% off the regulated tariff
Late Payment Charge	\$5.35 per bill	
Early Termination Charge	Termination Rate × Unexpired Months Termination Rate per month: HDB 1-Room \$10.70 / HDB 2-Room \$16.05 / HDB 3-Room \$21.40 / HDB 4-Room \$32.10 / HDB 5-Room \$37.45 / HDB Executive & Private Condominium \$42.80 / Terrace \$74.90 / Semi-Detached \$101.65 / Bungalow \$214	

(Adapted from source: <https://www.ema.gov.sg/openelectricitymarket.aspx>)

The historical electricity tariff rate of SP Group is shown below.

SP Group Electricity Tariff					
Rates (cents/kWh) are exclusive of 7% Goods and Services Tax (GST)					
January 2018	April 2018	July 2018	October 2018	January 2019	April 2019
21.56	22.15	23.65	24.13	21.85	22.79

(Adapted from source: <https://www.spgroup.com.sg>)

