

*Visit*

**FREETESTPAPER.com**

*for more papers*



Website: [freetestpaper.com](http://www.freetestpaper.com)



[Facebook.com/freetestpaper](https://www.facebook.com/freetestpaper)



[Twitter.com/freetestpaper](https://www.twitter.com/freetestpaper)

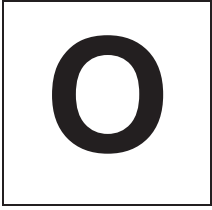

**ANDERSON SECONDARY SCHOOL**  
**Preliminary Examination 2020**  
**Secondary Four Express & Five Normal**



CANDIDATE NAME:

CLASS:

INDEX NUMBER:

**MATHEMATICS****4048/01**

Paper 1

**29 July 2020****2 hours****0800-1000h**

Candidates answer on the Question Paper

Additional Materials: Nil

**READ THESE INSTRUCTIONS FIRST**

Write your name, class and index number in the spaces at the top of this page.

Write in dark blue or black pen.

You may use an HB pencil for any diagrams or graphs.

Do not use paper clips, highlighters, glue or correction fluid/tape.

Answer **all** the questions.

If working is needed for any question it must be **neatly and clearly** shown in the space below the question.

Omission of essential working will result in loss of marks.

The use of an approved scientific calculator is expected, where appropriate.

If the degree of accuracy is not specified in the question, and if the answer is not exact, give the answer to three significant figures. Give answers in degrees to one decimal place.

For  $\pi$ , use either your calculator value or 3.142, unless the question requires the answer in terms of  $\pi$ .

At the end of the examination, fasten all your work securely together.

The number of marks is given in brackets [ ] at the end of each question or part question.

The total of the marks for this paper is 80.

*Mathematical Formulae**Compound Interest*

$$\text{Total amount} = P \left[ 1 + \frac{r}{100} \right]^n$$

*Mensuration*

$$\text{Curved surface area of a cone} = \pi r l$$

$$\text{Surface area of a sphere} = 4\pi r^2$$

$$\text{Volume of a cone} = \frac{1}{3} \pi r^2 h$$

$$\text{Volume of a sphere} = \frac{4}{3} \pi r^3$$

$$\text{Area of triangle } ABC = \frac{1}{2} ab \sin C$$

$$\text{Arc length} = r\theta, \text{ where } \theta \text{ is in radians}$$

$$\text{Sector area} = \frac{1}{2} r^2 \theta, \text{ where } \theta \text{ is in radians}$$

*Trigonometry*

$$\frac{a}{\sin A} = \frac{b}{\sin B} = \frac{c}{\sin C}$$

$$a^2 = b^2 + c^2 - 2bc \cos A$$

*Statistics*

$$\text{Mean} = \frac{\Sigma fx}{\Sigma f}$$

$$\text{Standard deviation} = \sqrt{\frac{\Sigma fx^2}{\Sigma f} - \left( \frac{\Sigma fx}{\Sigma f} \right)^2}$$

- 1 The number of spectators who attended a football match was 40 000 when rounded off to 1 significant figure. State the smallest and largest possible turnout for the match.

Answer smallest = .....

largest = ..... [2]

---

- 2 (a) Factorise  $x^2 + 9y^2 - 6xy - 1$  completely.

Answer ..... [2]

- (b) Express  $\frac{2}{3(x-4)^2} + \frac{1}{4-x}$  as a single fraction.

Answer ..... [2]

---

- 3 (a) Given that  $v$  is inversely proportional to  $t^3$  and  $v = 20$  for a particular value of  $t$ , find the new value of  $v$  when this value of  $t$  is doubled.

Answer ..... [3]

- (b) Given that  $f$  is directly proportional to  $v^2$ , sketch a graph of  $f$  against  $v$  in the axes drawn below.

Answer

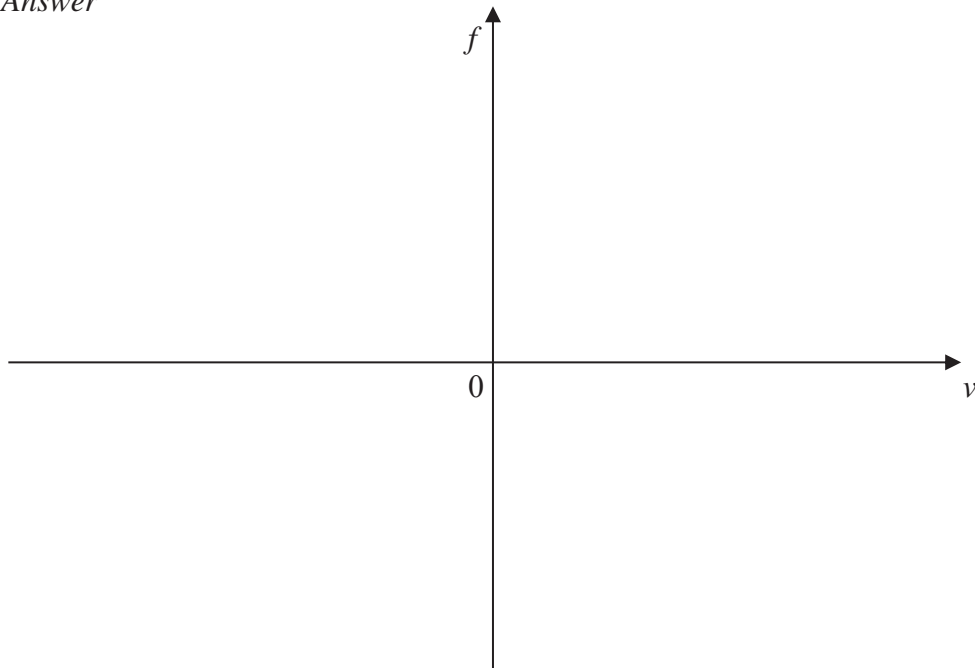

[1]

4 The total area of a town is  $36 \text{ km}^2$ . It is represented by a total area of  $4 \text{ cm}^2$  on a map.

(a) Express the scale of the map in the form  $1 : r$ .

*Answer* 1: ..... [2]

(b) Find the area of the town on a second map with scale is  $1 : 60\,000$ . Leave your answer in  $\text{cm}^2$ .

*Answer* ..... $\text{cm}^2$  [2]

5 (a) Solve the inequality  $9 - 5x < 2 - \frac{x}{4} \leq \frac{x}{3} - \frac{4x}{7}$ .

Answer ..... [3]

(b) Solve the equation  $\frac{3}{(2x-1)^2} = \frac{1}{3}$ .

Answer  $x = \dots$  or  $\dots$  [2]

- 6 (a) Simplify  $\left(\frac{x^6}{25y^4}\right)^{-\frac{1}{2}}$ , giving your answer in positive indices.

*Answer* ..... [2]

- (b) Solve the equation  $9\sqrt[3]{3^{3x}} = \frac{1}{3^{3(2-x)}}$ .

*Answer*  $x =$  ..... [3]

- (c) Given that  $a > 0$  and  $n$  is an even number, deduce the number of solutions for the equation  $ax^n - x = 0$ . Explain your answer clearly.

*Answer* .....

.....

.....

..... [3]

7 (a) Express  $x^2 - 2x + 3$  in the form  $(x - a)^2 + b$ .

Answer ..... [2]

(b) Hence state the minimum value of  $x^2 - 2x + 3$ .

Answer ..... [1]

(c) State the equation of the line of symmetry of the graph of  $y = x^2 - 2x + 3$ .

Answer ..... [1]

8 (a) Express 13 824 as a product of its prime factors.

Answer  $13\ 824 = \dots\dots\dots$  [1]

(b) Using your answer to part (a), explain why 13 824 is a perfect cube.

Answer.....

.....

..... [1]

(c) Given that  $a$  and  $b$  are both prime numbers and  $\frac{a}{b} < 1$ , find the values of  $a$  and  $b$  such that  $\frac{a}{b} \times 13\,824$  is a perfect square.

Answer  $a =$  .....

$b =$  ..... [2]

9 Solve the following simultaneous equations.

$$4x - y = -4$$

$$\frac{1}{3}y + x = \frac{5}{2}$$

Answer  $x =$  .....

$y =$  ..... [3]

10 A is the point  $(-4, 2)$  and  $B$  is the point  $(3, 0)$ .

(a) Find the equation of the line  $AB$ .

*Answer* ..... [3]

(b) Find the length  $AB$ .

*Answer* .....units [2]

(c) State the number of points of intersection between the line  $AB$  and the line  $y = \frac{1}{2}x + 1$ . Explain your answer.

*Answer*.....  
.....  
..... [2]

11 Consider the sequence

$$1^2 - 5, \quad 2^2 - 7, \quad 3^2 - 9, \quad 4^2 - 11, \quad \dots$$

(a) Find an expression, in terms of  $n$ , for the  $n$ th term,  $T_n$ , of this sequence.

$$\text{Answer } T_n = \dots\dots\dots [1]$$

(b) Evaluate  $T_8$ .

$$\text{Answer } T_8 = \dots\dots\dots [1]$$

12  $A$  and  $B$  are two geometrically similar objects such that

$$\frac{\text{surface area of } A}{\text{surface area of } B} = \frac{y}{y+7} \quad \text{and} \quad \frac{\text{volume of } A}{\text{volume of } B} = \frac{1}{8}.$$

Find the value of  $y$ .

$$\text{Answer } y = \dots\dots\dots [3]$$

- 13 In the diagram below,  $PQ = 22$  km,  $QR = 12$  km, the bearing of  $P$  from  $Q$  is  $048^\circ$  and angle  $PQR$  is acute.  $S$  is due east of  $Q$ . The area of triangle  $PQR$  is thrice the area of triangle  $SQR$ . Find angle  $SQR$ .

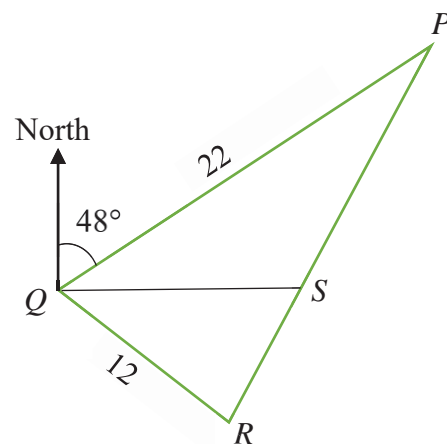

Answer angle  $SQR = \dots\dots\dots^\circ$  [3]

- 14 The diagram shows the speed-time graph of a racing car driving along a road. The total distance travelled is 720 m.

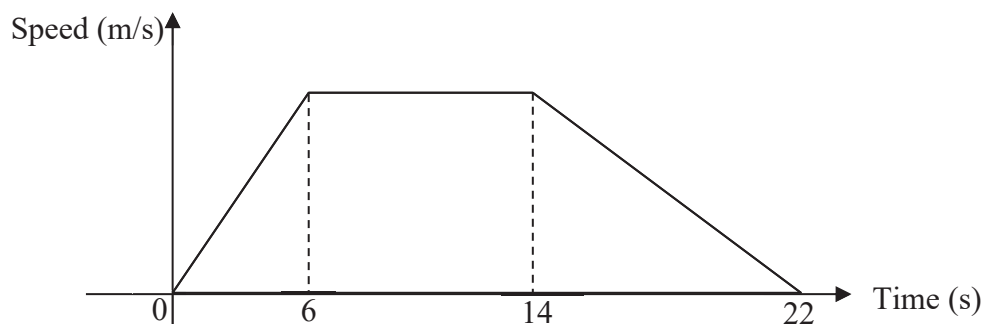

- (a) Calculate the maximum speed of the racing car.

Answer  $\dots\dots\dots$  m/s [2]

(b) Find the deceleration in the last 8 seconds of the journey.

Answer .....  $\text{m/s}^2$  [1]

(c) Find the speed of the racing car at time  $t = 16$  s.

Answer .....  $\text{m/s}$  [2]

(d) Sketch the distance-time graph for the first 14 seconds of the racing car's journey, in the axes provided below. [2]

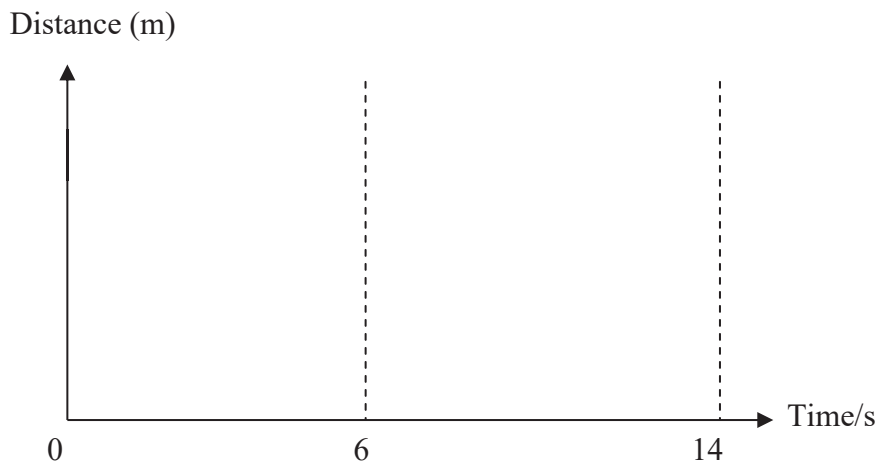

---

---

- 15 In the diagram below,  $O$  is the centre of both circle  $ABCD$  and circle  $PQR$ .  $PQ$  and  $PR$  are tangents to the smaller circle at points  $D$  and  $C$  respectively.

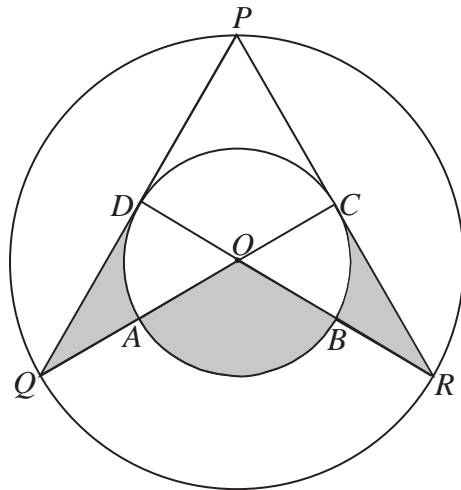

- (a) Show that triangle  $PQC$  is congruent to triangle  $PRD$ .

Answer.....  
 .....  
 .....  
 ..... [3]

- (b) Show that triangle  $OCR$  is similar to triangle  $PDR$ .

Answer.....  
 .....  
 ..... [2]

- 16 The infographic shown below provides a statistical comparison of the latest coronavirus to other infectious diseases which are similar in nature.

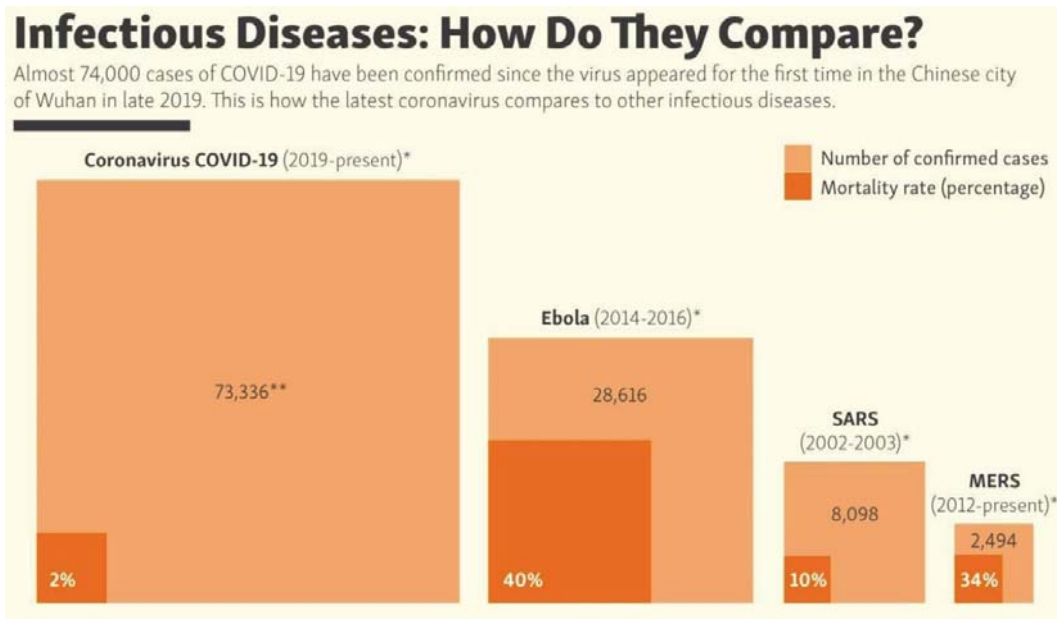

Explain why this infographic could be misleading in nature.

Answer.....

.....

.....

.....

[2]

- 17 (a) The radius of planet A and B is approximately  $6.95 \times 10^5$  km and  $6 \times 10^6$  m. Find the difference in the diameter, in kilometres, of both the planets. Give your answer in standard form.

*Answer*..... km [2]

- (b) (i) Factorise completely  $(y-2)^3 - 4y + 8$ .

*Answer* ..... [2]

- (ii) Hence, find the minimum value of  $(y-2)^3 - 4y + 8$  when  $y \geq 4$ . .

*Answer* ..... [1]

- 18 The test score of Class 4A consisting of 25 students is given in the stem-and-leaf diagram below.

Stem	Leaf						
4	0	2					
5	1	3	3				
6	3	4	8	8	8	9	
7	0	1	2	5	6	7	8
8	2	4	7	7	8		
9	3	5					

Legend: 4|0 represents 40.

- (a) Find the median score.

*Answer* ..... [1]

- (b) Find the interquartile range.

*Answer* ..... [2]

- (c) Find the modal score.

*Answer* ..... [1]

- (d) A score of at least 76 is required for a student to obtain a distinction. Find the percentage of students in class 4A who obtained a distinction.

*Answer* ..... [1]

- 19 The diagram below shows a plot of farming land  $ABCD$ .

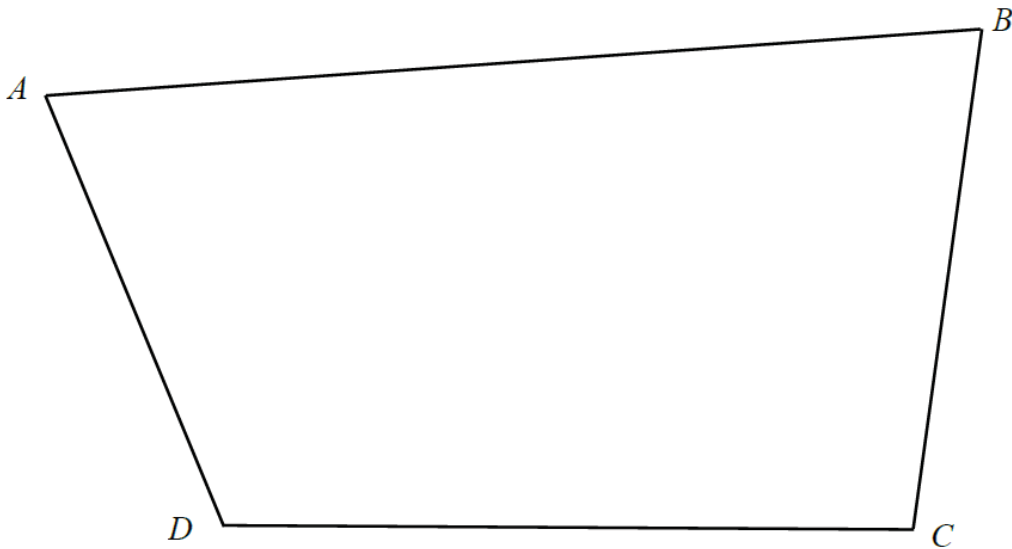

- (a) Construct the perpendicular bisector of  $AB$ . [1]
- (b) Construct the bisector of angle  $ADC$ . [1]
- (c) A water pump is to be installed at  $ABCD$  such that it is closer to the line  $CD$  than the line  $AD$ . Shade the region representing the area where the water pump can be installed. [1]

---

**End of Paper**



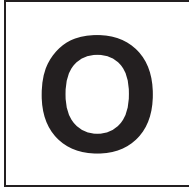

**ANDERSON SECONDARY SCHOOL**  
**Preliminary Examination 2020**  
**Secondary Four Express and Five Normal**



CANDIDATE NAME:

CLASS:

INDEX NUMBER:

**MATHEMATICS**

**4048/02**

Paper 2

**30 July 2020**

**2 hours 30 minutes**

**0800 – 1030h**

Candidates answer on the Question Paper.

Additional Materials: Nil

**READ THESE INSTRUCTIONS FIRST**

**Write your name, class and index number on all the work you hand in.**

Write in dark blue or black pen.

You may use an HB pencil for any diagrams or graphs.

Do not use staples, paper clips, highlighters, glue, correction fluid or tape.

**Answer all questions on the answer spaces provided.**

If working is needed for any question, it must be shown with the answer.

Omission of essential working will result in loss of marks.

The use of an approved scientific calculator is expected, where appropriate.

If the degree of accuracy is not specified in the question, and if the answer is not exact, give the answer to three significant figures. Give answers in degrees to one decimal place.

For  $\pi$ , use either your calculator value or 3.142, unless the question requires the answer in terms of  $\pi$ .

At the end of the examination, fasten all your work securely together.

The number of marks is given in brackets [ ] at the end of each question or part question.

The total of the marks for this paper is **100**.

**Mathematical Formulae****Compound Interest**

$$\text{Total amount} = P \left[ 1 + \frac{r}{100} \right]^n$$

**Mensuration**

$$\text{Curved surface area of a cone} = \pi r l$$

$$\text{Surface area of a sphere} = 4\pi r^2$$

$$\text{Volume of a cone} = \frac{1}{3} \pi r^2 h$$

$$\text{Volume of a sphere} = \frac{4}{3} \pi r^3$$

$$\text{Area of triangle } ABC = \frac{1}{2} ab \sin C$$

$$\text{Arc length} = r\theta, \text{ where } \theta \text{ is in radians}$$

$$\text{Sector area} = \frac{1}{2} r^2 \theta, \text{ where } \theta \text{ is in radians}$$

**Trigonometry**

$$\frac{a}{\sin A} = \frac{b}{\sin B} = \frac{c}{\sin C}$$

$$a^2 = b^2 + c^2 - 2bc \cos A$$

**Statistics**

$$\text{Mean} = \frac{\sum fx}{\sum f}$$

$$\text{Standard deviation} = \sqrt{\frac{\sum fx^2}{\sum f} - \left( \frac{\sum fx}{\sum f} \right)^2}$$

1 (a) It is given that  $\frac{2px+9qy}{2py+qx} = 3$ ,  $p$  and  $q$  are constants and  $2p \neq 3q$ .

(i) Show that  $x = 3y$ . [2]

(ii) Evaluate  $\frac{x+y}{y}$ .

Answer \_\_\_\_\_ [2]

(b) Simplify  $\frac{3a+7b}{16a^2-49(a+b)^2}$ .

*Answer* \_\_\_\_\_ [3]

(c) Solve the equation  $2^{x+3} = 320 - 2^{x+1}$ .

*Answer*  $x =$  \_\_\_\_\_ [3]

2 The Singapore Indoor Stadium has a seating capacity of 12 000. For shows in February 2020, tickets for Disney on Ice are priced at \$50 per adult and \$35 per child.

- (a) For one of the evening shows in February, 85% of the seats in the stadium are occupied. 3200 of the people present are children. Calculate the total amount of money collected from the sale of tickets for that evening.

*Answer* \$ \_\_\_\_\_ [2]

- (b) In light of the Covid-19 situation, the price of the adult ticket for a show in February 2020 is 20% cheaper than a show in December 2019. Calculate the price of the adult ticket in December 2019.

*Answer* \$ \_\_\_\_\_ [2]

- (c) The amount of money collected from the sales of tickets from one day in February 2020 was \$375 000. This sum of money is divided among cost of operation, wages and profit in the ratio 3 : 5 : 7.  
The profit is invested at a rate of 4% per annum compounded quarterly for a period of 2 years.  
Calculate the compound interest earned.

*Answer* \$ \_\_\_\_\_ [3]

- 3  $ODE$  is a quadrant with centre  $O$  and radius 6 cm.  
 $ABC$  is a circle with centre  $X$  which touches the sides of the quadrant  $ODE$  at the points  $A$ ,  $B$  and  $C$ .

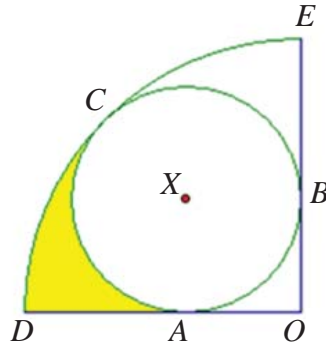

- (a) Show that the radius of the circle  $ABC$  is 2.49 cm, correct to 3 significant figures. [3]

- (b) Find the length of the minor arc  $AC$ .

Answer \_\_\_\_\_ cm [3]

- (c) Find the area of the shaded region.

Answer \_\_\_\_\_  $\text{cm}^2$  [3]

- 4 (a) It is given that  $\mathcal{E} = \{x : x \text{ is a real number such that } 10 \leq x \leq 30\}$ ,  
 $A = \{x : x \text{ is a multiple of } 4\}$ ,  
 $B = \{x : x \text{ is a multiple of } 3\}$  and  
 $C = \{x : x \text{ is a multiple of } 12\}$ .

- (i) List all the elements in  $B$ .

Answer  $B =$  \_\_\_\_\_ [1]

- (ii) Find  $n(A' \cap B')$ .

Answer \_\_\_\_\_ [1]

- (iii) Write down, in set notation, the relationship between sets  $A$ ,  $B$  and  $C$ .

Answer \_\_\_\_\_ [1]

- (b) (i) On the Venn diagram shown in the answer space, shade the set  $X' \cup Y$ . [1]

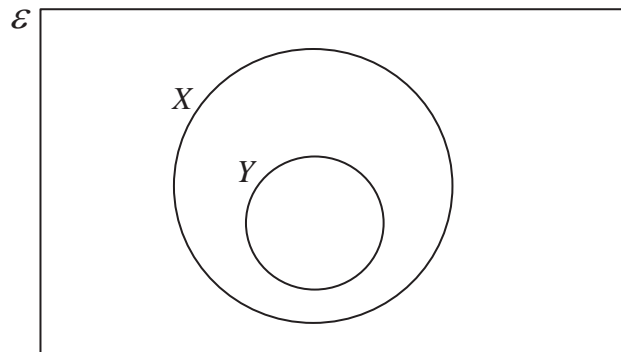

- (ii) Use set notation to describe the set shaded in the Venn diagram below.

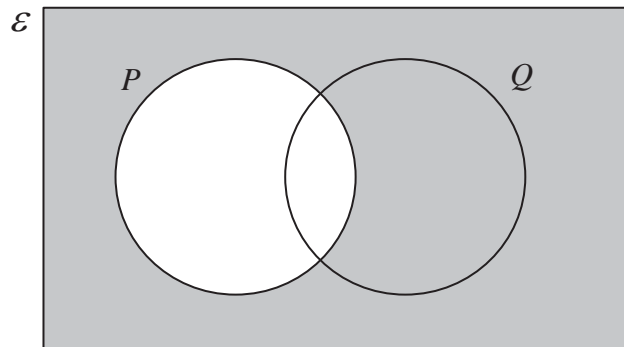

Answer \_\_\_\_\_ [1]

5

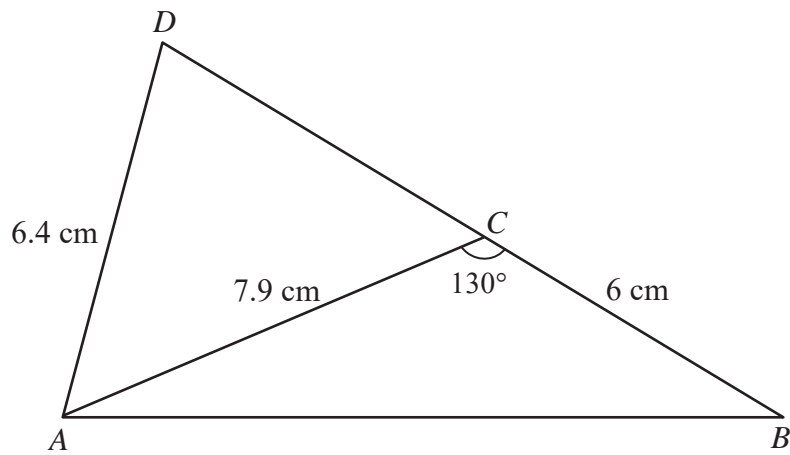

$BCD$  is a straight line.

$AC = 7.9$  cm,  $AD = 6.4$  cm and  $BC = 6$  cm.

Angle  $ACB = 130^\circ$ .

(a) Calculate  $AB$ .

Answer \_\_\_\_\_ cm [3]

(b) Calculate angle  $ADC$ .

Answer \_\_\_\_\_ [2]

(c) Calculate the shortest distance from  $C$  to  $AB$ .

Answer \_\_\_\_\_ cm [3]

- 6 The table shows the number of bottles of AndClean hand sanitizers, sold in three shops over the months of December 2019, January and February 2020.

	Selling Price (\$)	December 2019	January 2020	February 2020
Shop A	3.80	280	320	345
Shop B	3.50	250	265	280
Shop C	4.00	190	235	290

The selling price of AndClean hand sanitizers in each of the three shops can be represented by the matrix  $\mathbf{P} = (3.80 \ 3.50 \ 4.00)$ .

- (a) Write down a  $3 \times 3$  matrix  $\mathbf{Q}$  to represent the number of bottles of AndClean hand sanitizers sold in each of the three shops over the three months.

Answer  $\mathbf{Q} =$  \_\_\_\_\_ [1]

- (b) (i) State a  $3 \times 1$  matrix  $\mathbf{R}$  such that the product  $\mathbf{QR}$  represents the total number of AndClean hand sanitizers sold in each shop for the three months.

Answer  $\mathbf{R} =$  \_\_\_\_\_ [1]

- (ii) Evaluate the product  $\mathbf{QR}$ .

Answer  $\mathbf{QR} =$  \_\_\_\_\_ [1]

- (c) Given that the cost price of a bottle of AndClean hand sanitizers is \$2.60, show that the profit each shop makes for selling a bottle of AndClean is given by  $\mathbf{S} = \begin{pmatrix} 1.20 & 0.90 & 1.40 \end{pmatrix}$ . [1]

- (d) (i) Evaluate the matrix  $\mathbf{T} = \mathbf{S}(\mathbf{QR})$ .

*Answer*  $\mathbf{T} =$  \_\_\_\_\_ [1]

- (ii) Explain what the elements in  $\mathbf{T}$  represent.

*Answer* \_\_\_\_\_  
 \_\_\_\_\_  
 \_\_\_\_\_ [1]

- (e) The World Health Organisation classified Covid-19 as a pandemic in March 2020. The number of bottles of AndClean hand sanitizers sold in March 2020 increased by 40% across all 3 shops as compared to February 2020.

Using scalar multiplication, find the number of bottles of AndClean sold in each of the three shops in March 2020.

*Answer* \_\_\_\_\_ [2]

- 7 The variables  $x$  and  $y$  are connected by the equation  $y = \frac{1}{5}x^3 - \frac{4}{5}x^2$ .

Some corresponding values of  $x$  and  $y$  are given in the following table.

$x$	-2	-1	0	1	2	3	4	5
$y$	-4.8	-1	0	-0.6	$p$	-1.8	0	5

- (a) Calculate the value of  $p$ .

*Answer*  $p =$  \_\_\_\_\_ [1]

- (b) Using a scale of 2 cm to 1 unit, draw a horizontal  $x$ -axis for  $-2 \leq x \leq 5$ .  
 Using a scale of 2 cm to 1 unit, draw a vertical  $y$ -axis for  $-5 \leq y \leq 5$ .  
 On the grid provided, plot the points given in the table and join them with a smooth curve. [3]

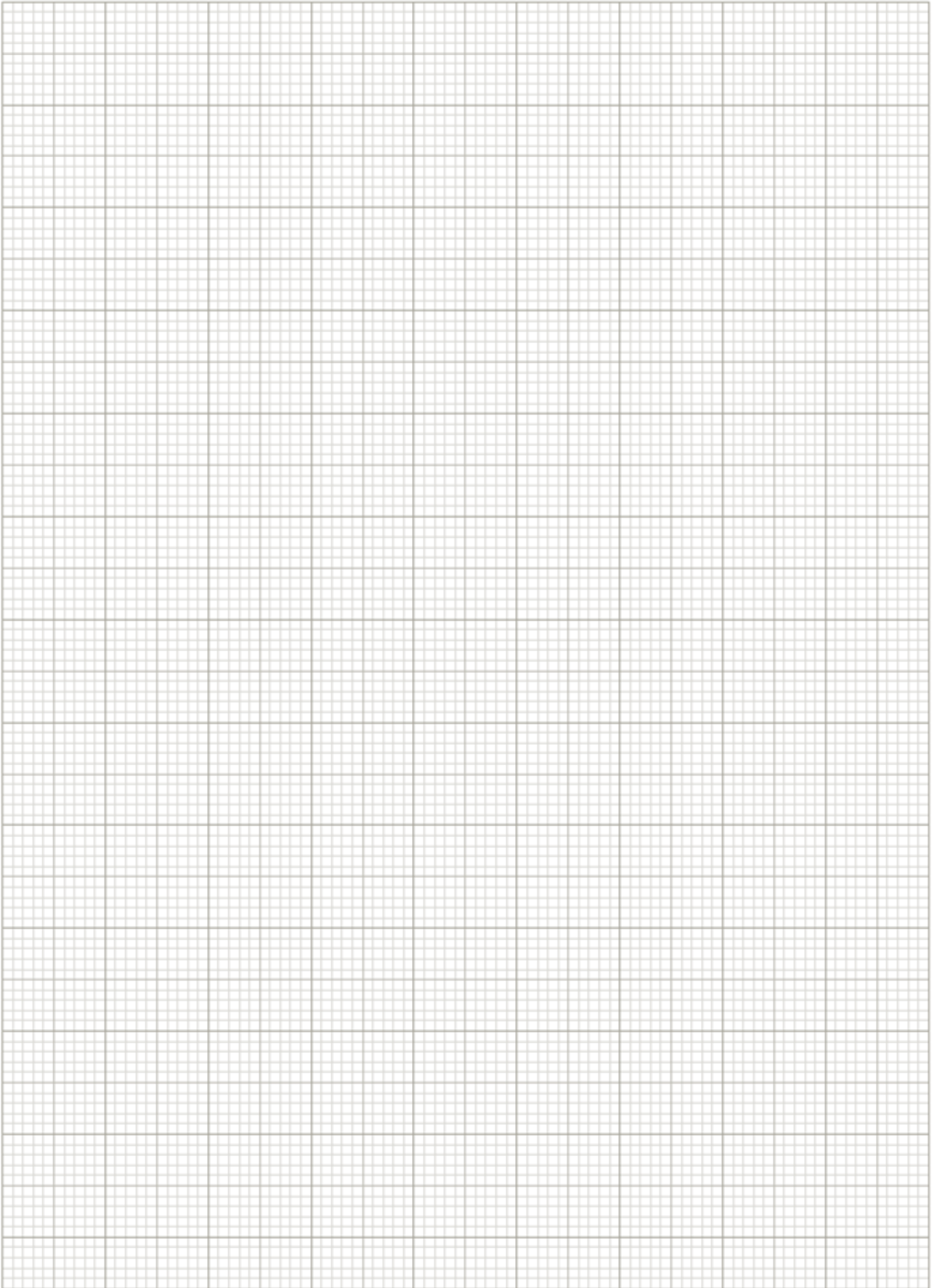

- (c) Use your graph to solve the equation  $\frac{1}{5}x^3 - \frac{4}{5}x^2 - 2 = 0$ .

*Answer*  $x =$  \_\_\_\_\_ [2]

- (d) By drawing a tangent, find the gradient of the curve at the point (4, 0).

*Answer* \_\_\_\_\_ [2]

- (e) (i) On the same axes, draw the line  $y = 4 - 2x$  for  $0 \leq x \leq 5$ . [1]
- (ii) Write down the  $x$ -coordinate of the point where this line intersects the curve.

*Answer* \_\_\_\_\_ [1]

- (iii) This value of  $x$  is a solution of the equation  $x^3 - 4x^2 + Ax + B = 0$ .  
Find the value of  $A$  and of  $B$ .

*Answer*  $A =$  \_\_\_\_\_ ,  $B =$  \_\_\_\_\_ [3]

8

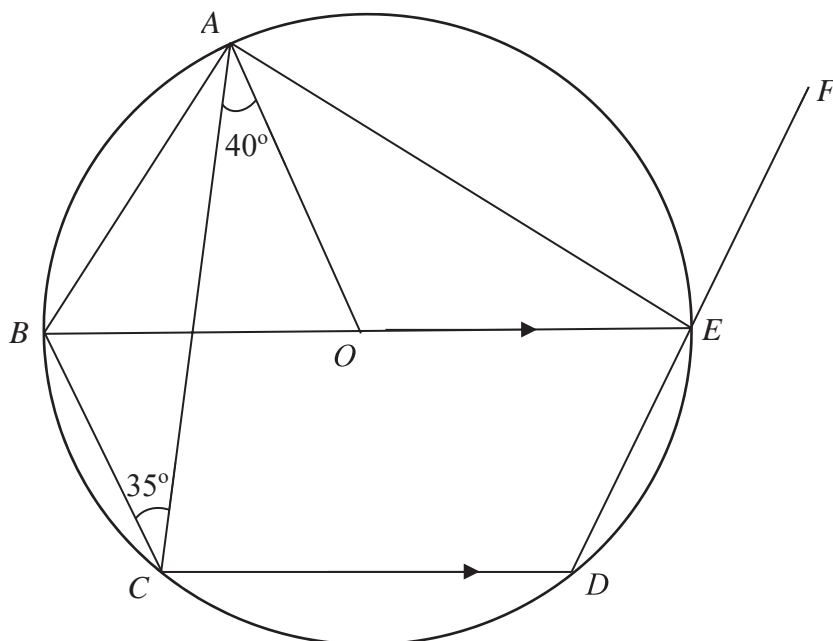

$A, B, C, D$  and  $E$  are points on the circle, with centre  $O$ .  
 The diameter of the circle,  $BE$ , is parallel to  $CD$ .  
 Angle  $OAC = 40^\circ$  and angle  $ACB = 35^\circ$ .  
 $DEF$  is a straight line.

Find, giving reasons for each answer,

(a) angle  $OEA$ ,

Answer \_\_\_\_\_ [1]

(b) reflex angle  $AOB$ ,

Answer \_\_\_\_\_ [2]

(c) angle  $BAC$ ,

*Answer* \_\_\_\_\_ [2]

(d) angle  $FEB$ ,

*Answer* \_\_\_\_\_ [2]

(e) angle  $DOE$ .

*Answer* \_\_\_\_\_ [2]

- 9 (a) Students from three classes  $A$ ,  $B$  and  $C$  took a Mathematics examination and their mean marks and standard deviation were recorded in the table.

Class	Number of students	Mean mark	Standard deviation
$A$	15	85.4	0.313
$B$	10	86.5	2.128
$C$	14	75	0

- (i) State how it may be deduced from the data that the mark scored by each student in class  $C$  was 75 marks.

Answer \_\_\_\_\_  
 \_\_\_\_\_  
 \_\_\_\_\_  
 \_\_\_\_\_ [2]

- (ii) Compare the performance of the classes.

Answer \_\_\_\_\_  
 \_\_\_\_\_  
 \_\_\_\_\_  
 \_\_\_\_\_ [2]

- (iii) A new student Raymond joined class  $C$  and the standard deviation of the marks of class  $C$  changed to 2.30. Find the possible values of Raymond's marks, giving your answer correct to the nearest whole number.

Answer \_\_\_\_\_ or \_\_\_\_\_ [4]

(b) A box contains 8 cards, numbered '1' to '8' respectively. A card is drawn with replacement from the box until an '8' is obtained. Find the probability that

(i) the first draw was **not** an '8',

Answer \_\_\_\_\_ [1]

(ii) it will take exactly  $n$  draws to obtain an '8', giving your answer in terms of  $n$ ,

Answer \_\_\_\_\_ [1]

(iii) it will take at least  $n$  draws to obtain an '8', giving your answer in terms of  $n$ .

Answer \_\_\_\_\_ [1]

(c) Krystal said that since she has not drawn an '8' for the last 15 draws, her next draw will likely be an '8'. Comment on the validity of her statement.

Answer \_\_\_\_\_

\_\_\_\_\_

\_\_\_\_\_

\_\_\_\_\_

\_\_\_\_\_ [2]

**10** The volume of mixture required to make one cookie is  $15 \text{ cm}^3$ .

- (a)** The mixture is first rolled into a sphere before baking.  
Calculate the radius of the sphere.

*Answer* \_\_\_\_\_ cm [2]

- (b)** After it is baked, the cookie takes the shape of a cylinder of radius 3 cm and height of 6 mm due to air trapped in the cookie during baking.

- (i)** Calculate the volume of air trapped in the cookie.

*Answer* \_\_\_\_\_  $\text{cm}^3$  [2]

- (ii)** Express this volume of air as a percentage of the total volume of the cookie.

*Answer* \_\_\_\_\_ % [1]

- (c) The cookies are then packed into a box in the shape of a regular hexagon which can contain 7 cookies.

The cross-section of the box is as shown in Figure 1.

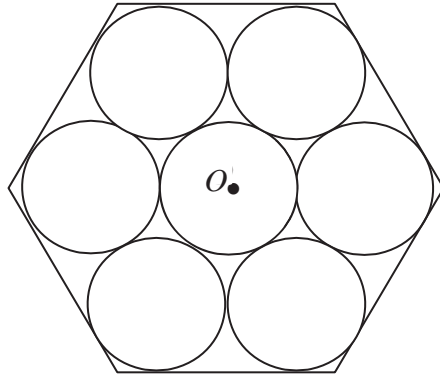

Figure 1

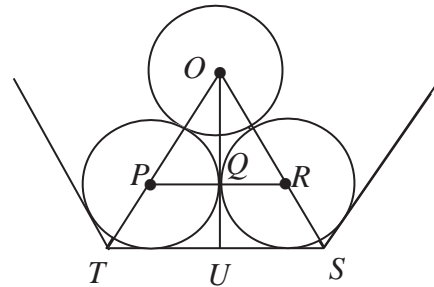

Figure 2

Three of the cookies are shown in Figure 2.

$O$  is the centre of the hexagonal box and  $P$  and  $R$  are the centres of two cookies as shown in Figure 2.  $Q$  is the point where the two cookies touch and  $U$  is the midpoint of  $TS$ , a side of the box.

- (i) Calculate the length of  $OP$ .

Answer \_\_\_\_\_ cm [1]

- (ii) Calculate the length of  $OQ$ .

Answer \_\_\_\_\_ cm [2]

- (iii) Calculate the length of one side of the box.

Answer \_\_\_\_\_ cm [2]

- 11 The interior of a chest freezer as shown in Figure A can be modelled as a cuboid with length and height of 100 cm and a width of 55 cm as shown in Figure B.



**Figure A**

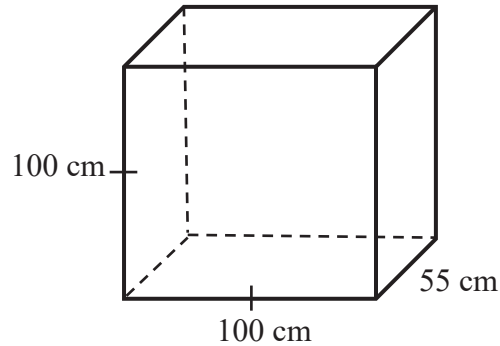

**Figure B**

Cool air must be circulated inside the freezer at any time.

When cool air meets the warm and humid air that is outside of the freezer, frost is formed at the point of contact.

To allow the freezer to work efficiently, defrosting is required when the layer of frost exceeds 1 cm.

- (a) Due to the opening and closing of the freezer door, frost of  $x$  cm is formed uniformly on the four vertical walls of the freezer. The area of the horizontal base of the freezer not covered by the frost is  $105(50 - x)$  cm<sup>2</sup>.

Explain if defrosting is required and show your calculations clearly.

*Answer* \_\_\_\_\_

\_\_\_\_\_

\_\_\_\_\_ [4]

- (b) Kara wants to design a box that can contain the freezer for shipping. There must be free space between the freezer and the box to allow for ease of removal and addition of protective materials to prevent scratches.

It is recommended to have a minimum distance of 2 cm of free space around the sides and a minimum distance of 3 cm of free space at the top. The thickness of the freezer wall and door of the freezer is 3.5 cm.

Find the smallest dimensions of the box required. State one assumption made in your calculation.

*Answer* Length = \_\_\_\_\_ cm [1]

Height = \_\_\_\_\_ cm [1]

Width = \_\_\_\_\_ cm [1]

Assumption : \_\_\_\_\_

\_\_\_\_\_

\_\_\_\_\_

\_\_\_\_\_ [1]

---

**END OF PAPER**

