

Visit

FREETESTPAPER.com

for more papers



Website: [freetestpaper.com](http://www.freetestpaper.com)



[Facebook.com/freetestpaper](https://www.facebook.com/freetestpaper)



[Twitter.com/freetestpaper](https://www.twitter.com/freetestpaper)

Name: _____

Register Number: _____

Class: _____

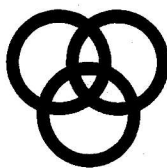

南橋中學

NAN CHIAU HIGH SCHOOL

**PRELIMINARY EXAMINATION 2021
SECONDARY FOUR EXPRESS**

For Marker's Use
80

Parent's Signature: _____

MATHEMATICS

4048/01

Paper 1

19 Aug 2021, Thursday

2 hours

Candidates answer on the Question Paper.

READ THESE INSTRUCTIONS FIRST

Write your name, class and index number on all the work you hand in.

Write in dark blue or black pen.

You may use an HB pencil for any diagrams or graphs.

Do not use staples, paper clips, glue or correction fluid.

Answer **all** questions.

If working is needed for any question it must be shown with the answer.

Omission of essential working will result in loss of marks.

The use of an approved scientific calculator is expected, where appropriate.

If the degree of accuracy is not specified in the question, and if the answer is not exact, give the answer to three significant figures. Give answers in degrees to one decimal place.

For π , use either your calculator value or 3.142, unless the question requires the answer in terms of π .

The number of marks is given in brackets [] at the end of each question or part question.

The total of the marks for this paper is 80.

This paper consists of 19 printed pages including the cover page.

Mathematical Formulae*Compound interest*

$$\text{Total amount} = P \left(1 + \frac{r}{100} \right)^n$$

Mensuration

$$\text{Curved surface area of a cone} = \pi r l$$

$$\text{Surface area of a sphere} = 4\pi r^2$$

$$\text{Volume of a cone} = \frac{1}{3} \pi r^2 h$$

$$\text{Volume of a sphere} = \frac{4}{3} \pi r^3$$

$$\text{Area of triangle } ABC = \frac{1}{2} ab \sin C$$

$$\text{Arc length} = r\theta, \text{ where } \theta \text{ is in radians}$$

$$\text{Sector area} = \frac{1}{2} r^2 \theta, \text{ where } \theta \text{ is in radians}$$

Trigonometry

$$\frac{a}{\sin A} = \frac{b}{\sin B} = \frac{c}{\sin C}$$

$$a^2 = b^2 + c^2 - 2bc \cos A$$

Statistics

$$\text{Mean} = \frac{\Sigma fx}{\Sigma f}$$

$$\text{Standard deviation} = \sqrt{\frac{\Sigma fx^2}{\Sigma f} - \left(\frac{\Sigma fx}{\Sigma f} \right)^2}$$

Answer all the questions.

- 1** Calculate $6.2 \times 10^{-7} \times 2.7 \times 10^{-5}$, giving your answer in standard form.

Answer [1]

-
- 2** Write the following numbers in order of size, starting with the smallest.

$$-\sqrt{9.87}, \quad -\frac{22}{7}, \quad -314.2\%, \quad -3.143$$

Answer [2]

-
- 3** Find the area of the smallest circle passing through the points (2, 4) and (5, 1). Express your answer in terms of π .

Answer units² [2]

4

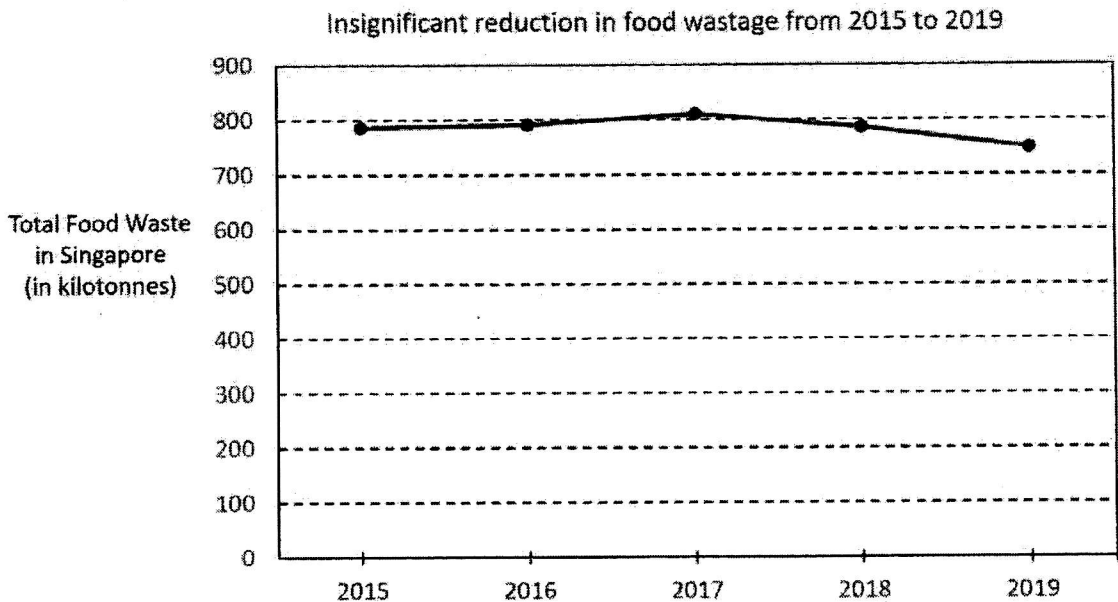

State one aspect of the graph that may be misleading and explain how this may lead to a misinterpretation of the graph.

.....

.....

.....

..... [2]

5 Two consecutive positive integers are multiplied. The product when rounded to the nearest hundred is 202100. Find the sum of the two positive integers.

Answer [2]

6 The diagrams *A*, *B*, *C*, *D*, *E* and *F* show six graphs of different functions.

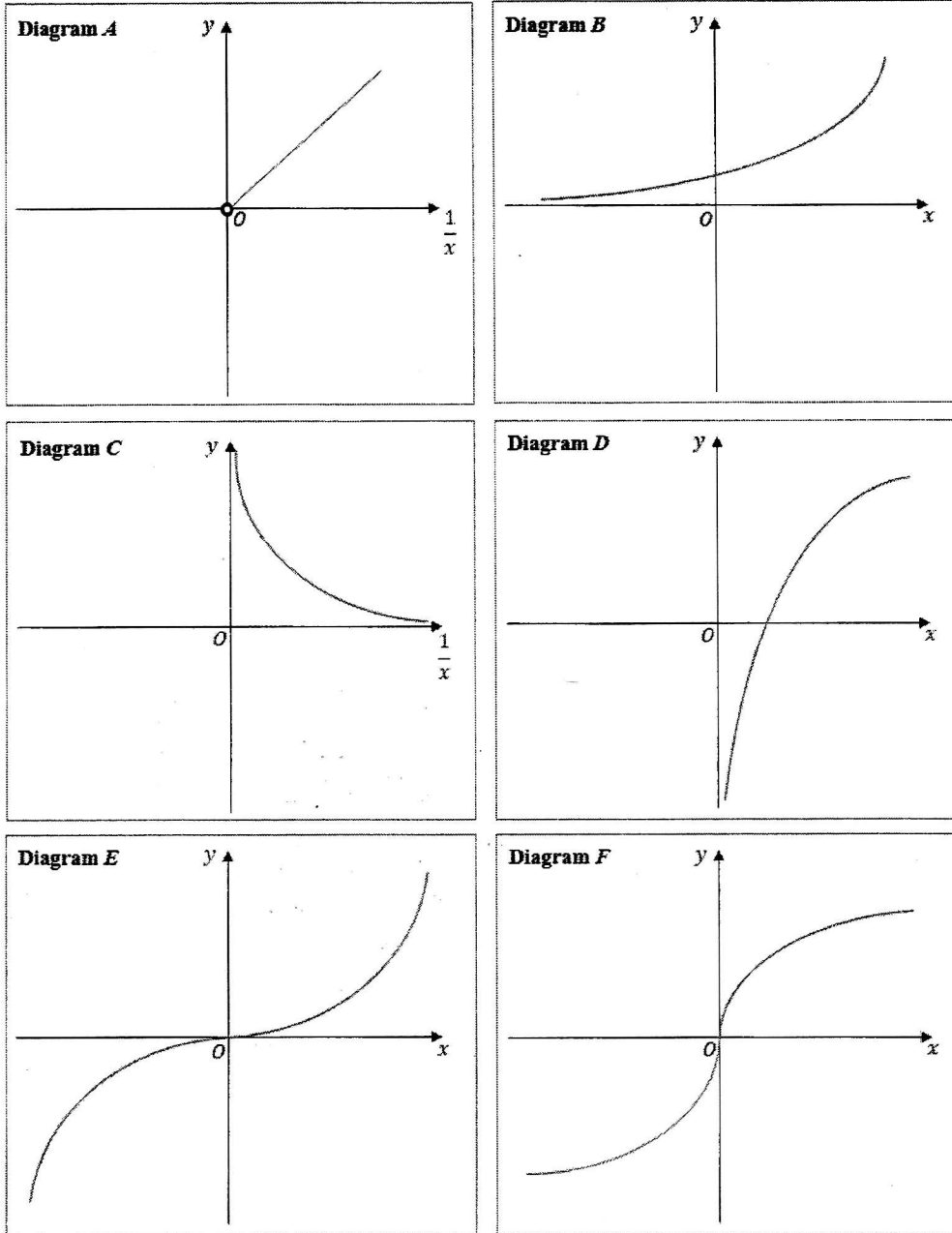

Select the diagram that best shows that

(a) y is inversely proportional to x ,

Diagram [1]

(b) $y = x^n$, where n is an odd integer greater than 1,

Diagram [1]

(c) $y = n^x$, where n is an integer greater than 1.

Diagram [1]

- 7 Naomi received a commission of \$35 750 from the sale of a house. This sum of money was divided among his expenditure, insurance premiums and savings in the ratio 5 : 4 : 6. The savings is invested at a rate of 0.25% per annum compounded quarterly for a period of 2 years. Calculate the compound interest earned.

Answer \$ [3]

-
- 8 In an experiment with 16 observations on x , the following results were obtained:

$$\sum x = 182, \quad \sum x^2 = 3548$$

One observation with value 20 was detected to be wrongly recorded and was replaced by its correct value 30. Find the corrected standard deviation.

Answer [3]

- 9 The solution of the inequality $-1 < \frac{1-x}{2} \leq k + 1$, where k is a constant, is represented on the number line below. Find the value of k .

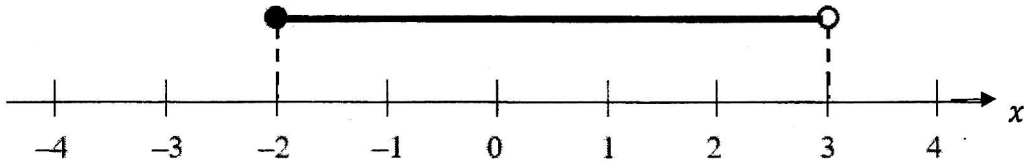

Answer $k = \dots\dots\dots$ [3]

- 10 (a) On the Venn diagram, shade the region which represents $(A \cup B') \cap (A' \cup B)$.

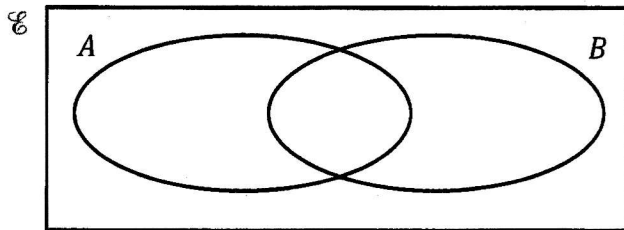

[1]

- (b) $\mathcal{U} = \{(x, y) : x + y \leq 10\}$
 $A = \{(0, 1), (1, 2), (1, 4), (1, 5)\}$
 $B = \{(1, 0), (1, 2), (1, 3), (2, 1), (3, 7)\}$

Underline the correct statements from the list below.

- $A \cap B = (1, 2)$ $\{1, 5\} \subset A$ $\emptyset \subset B$ $(2, 6) \in (A \cup B)'$ $A \subset B$

[2]

- 11 The difference of the two roots of the equation $3x^2 + 9x - k = 0$ is 13 units, where k is a constant. Find the value of k .

Answer $k = \dots\dots\dots$ [3]

-
- 12 Find an expression, in terms of r , for the volume of the largest cube that can possibly fit inside a sphere of radius r cm.

Answer $\dots\dots\dots$ cm³ [3]

- 13 (a) The scale of a map is 5 cm : 1 km. A reservoir has an actual area of 0.7 km^2 . Find the area, in square centimetres, of the reservoir on the map.

Answer cm^2 [2]

(b)

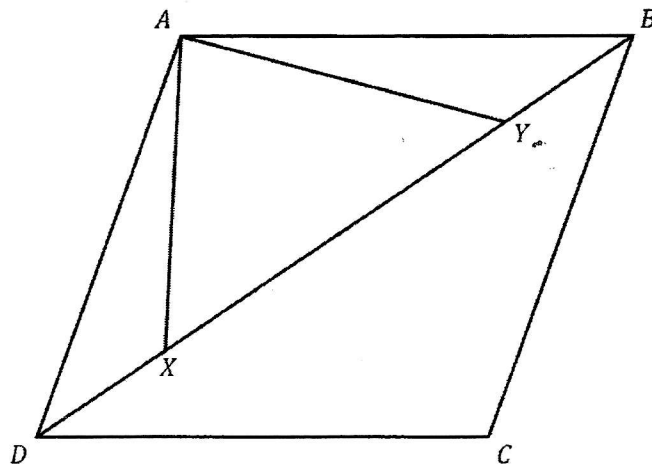

$ABCD$ is a rhombus. X and Y are points on BD such that $DX = YB$. Show that triangle ADX is congruent to triangle ABY . Give a reason for each statement you make.

Answer

[2]

- 14 A researcher conducted a Particle Filtration Efficiency (PFE) test on surgical masks and reusable masks which have been used for 24 hours. The box-and-whisker plots represent the distribution of PFE scores.

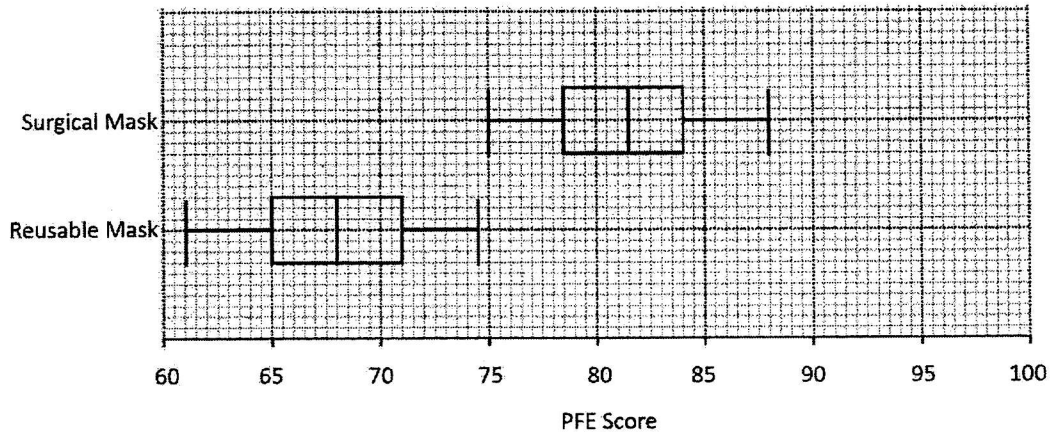

- (a) Find the range of the PFE scores for reusable masks.

Answer [1]

- (b) Find the interquartile range of the PFE scores for surgical masks.

Answer [1]

- (c) Make two comparisons between the PFE scores for surgical masks and reusable masks.

1

.....

.....

.....

.....

2

.....

.....

.....

..... [2]

15 (a) Factorise completely $x^4 - y^4$.

Answer [2]

(b) Given that $x^2 - 2xy = 1 - y^2$, express y in terms of x .

Answer or [3]

16 A bird is sitting on the top, T , of a vertical pole 20 m above the ground and the angle of elevation of the bird at T from a point O on the ground is 45° . The bird takes one second to fly horizontally at a constant speed from T to a point B away from O , maintaining a constant height of 20 m above the ground throughout its flight. The angle of elevation of the bird at B from O is reduced to 30° . Find the speed of the bird in m/s.

Answer m/s [3]

- 17 The population of a certain species of bacteria, N , is inversely proportional to the square root of the temperature, t °C, where $t > 0$. Find the percentage decrease in the temperature when the population is doubled.

Answer % [4]

- 18 Leroy has written down four numbers. The mean of these numbers is $2x + y$, the median is $x + y$ and the mode is $x - y$, where x and y are constants and $x > y$.

Find the four numbers in terms of x and y .

Answer [4]

19

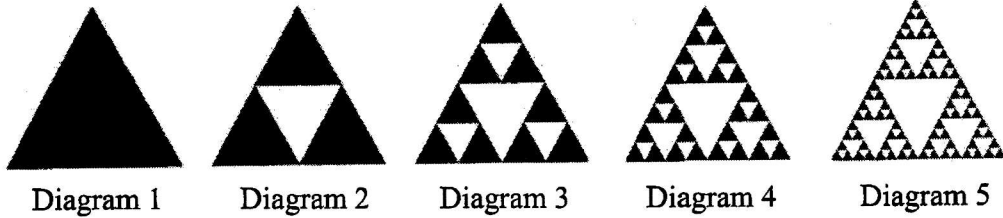

Diagram 1 shows an equilateral triangle with sides of length 1 unit. An inverted white equilateral triangle with sides of length $\frac{1}{2}$ unit is removed to form Diagram 2. Three inverted white equilateral triangles with sides of length $\frac{1}{4}$ unit is then removed from Diagram 2 to form Diagram 3. The process continues in this way.

- (a) Find an expression, in terms of n , for the total number of black triangles in Diagram n .

Answer [2]

- (b) Taking the area of Diagram 1 to be a units², find an expression, in terms of a and n , for the total area of black triangles in Diagram n .

Answer : units² [2]

- 20 Figure 1 shows an open container in the form of an isosceles trapezoidal prism $ABCDEFGH$ with square base $ABCD$ of sides x cm, where x is a constant. The faces $ABFE$ and $DCGH$ are perpendicular to the base $ABCD$. The container is then tilted along BC such that the face $BCGF$ and the base $ABCD$ make an angle of 30° each with the horizontal surface, as shown in Figure 2. Water is then filled into this empty container at a constant rate of x^3 cm³/min. Assume that the thickness of the container is negligible in this question.

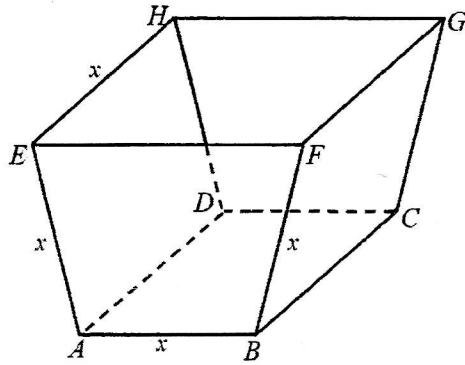

Figure 1

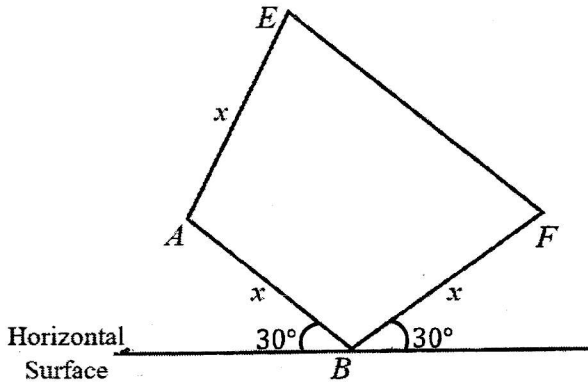

Figure 2

- (a) Find an expression, in terms of x , for the height of the water level just before the water in the container overflows.

Answer cm [1]

- (b) Find the time it takes to first fill this container to the height found in part (a), giving your answer to the nearest second.

Answer seconds [3]

- 21 A closed conical ornament has a circular base of radius 10 cm and height 25 cm, and contains mercury to a depth of 15 cm as shown in the figure below. The ornament is then inverted. Find the new depth, h cm, of the mercury.

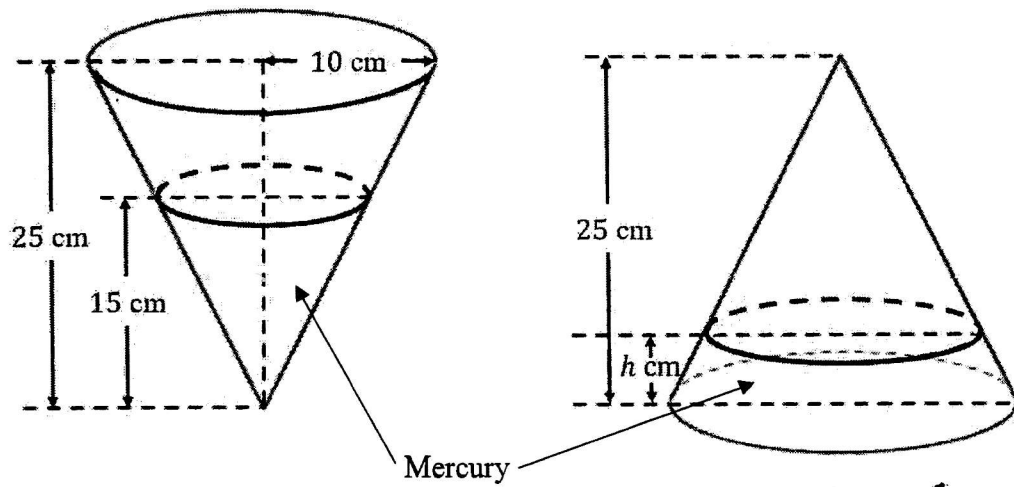

Answer $h = \dots\dots\dots$ cm [6]

22

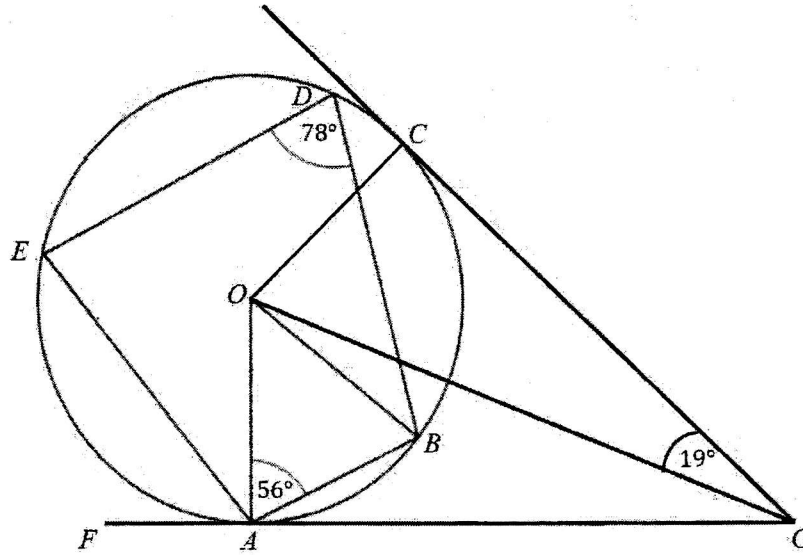

The diagram shows a circle, with centre O , passing through A , B , C , D and E . CG and FG are tangents to the circle at points C and A respectively. Angle $OAB = 56^\circ$, angle $BDE = 78^\circ$ and angle $OGC = 19^\circ$.

Find, giving reasons for each answer, the value of

(a) angle EAF ,



Answer [3]

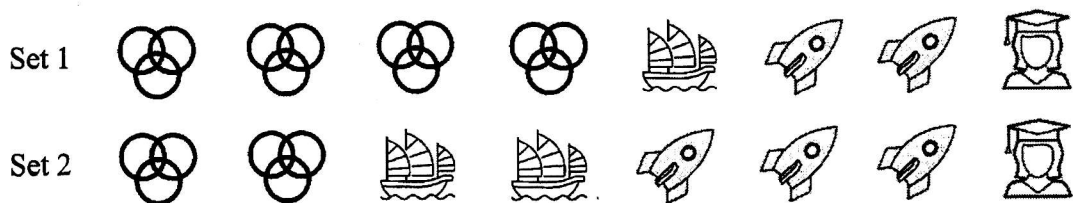

(b) angle BOG .

Answer [3]

23 A game has two sets of eight icons. One icon from each set is randomly chosen to be displayed on each turn, starting with set 1. The icons for each set are as follows.



For example, if an  icon is chosen from set 1 and an  icon is chosen from

set 2, the display would be  .

(a) Find the probability that, on one turn,

(i)   is displayed,





Answer [1]

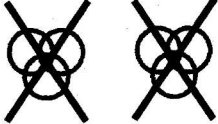

(ii) at least one  icon is displayed,

Answer [2]

- (b) The game is now programmed such that no two same icons will appear in the display.

For example, if an  icon is chosen in set 1, this icon will be removed from set 2 and an icon will be randomly chosen from the remaining six icons in set 2 as shown in the diagram below.

Set 2    

If now an  icon is chosen in set 2, the display would be  .

Draw a tree diagram to show the probabilities of all the possible outcomes.



NON CHIAM

P1

Answer Key

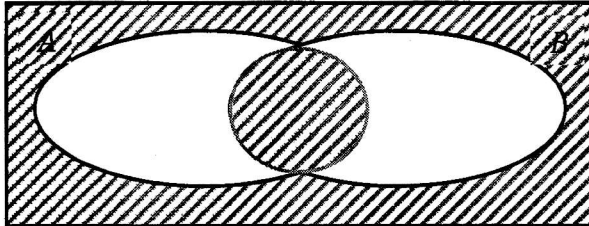
Qn	Solutions
1	1.674×10^{-11}
2	-3.143 , $-\frac{22}{7}$, -314.2% , $-\sqrt{9.87}$
3	$4\frac{1}{2}\pi$
4	<p>Aspect/Feature (Any one):</p> <ul style="list-style-type: none"> - The scale chosen for the vertical axis is inappropriate, due to the units of the total food waste being in kilotonnes, OR - The spacing of the numbers / intervals on the vertical axis is/are more condensed, <p>How it may lead to Misinterpretation:</p> <ul style="list-style-type: none"> - thus resulting in the differences of the food wastage across the years to be less significant than it should be.
5	899
6	(a) Diagram A (b) Diagram E (c) Diagram B
7	71.66 (nearest cents)
8	10.4 (3 s.f.)
9	$k = 0.5$
10(a)	
10(b)	$\emptyset \subset B$ and $(2, 6) \in (A \cup B)'$
11	$k = 120$
12	$\frac{8}{3\sqrt{3}}r^3 \text{ cm}^3$ Also Accept: $\frac{8\sqrt{3}}{9}r^3$ or $1.54r^3$ (3 s.f.)
13(a)	17.5 cm^2
13(b)	$\triangle ADX \equiv \triangle ABY$ (SAS)
14(a)	13.5
14(b)	5.5
14(c)	<ol style="list-style-type: none"> 1. The PFE scores of reusable masks are (generally) lower as the median of 68 is lower than the median of 81.5 for the surgical masks. 2. The PFE scores of reusable masks are (slightly) less consistent as the IQR of 6 is higher than the IQR of 5.5 for the surgical masks.

15(a)	$(x - y)(x + y)(x^2 + y^2)$
15(b)	$y = x + 1$ or $y = x - 1$
16	14.6 m/s (3 s.f.)
17	75%
18	$x - y, \quad x - y, \quad x + 3y, \quad 5x + 3y$
19(a)	3^{n-1} (b) $\left(\frac{3}{4}\right)^{n-1} a$
20(a)	$\frac{1}{2}x$
20(b)	26 seconds
21	$h = 1.95 \text{ cm}$ (3 s. f.)
22(a)	44°
22(b)	3°
23(a)(i)	$\frac{1}{8}$
23(a)(ii)	$\frac{5}{8}$
23(b)	<p>Set 1</p> <ul style="list-style-type: none"> Three rings: $\frac{1}{2}$ <ul style="list-style-type: none"> Sailboat: $\frac{1}{3}$ Rocket: $\frac{1}{2}$ Graduation cap: $\frac{1}{6}$ Sailboat: $\frac{1}{8}$ <ul style="list-style-type: none"> Three rings: $\frac{1}{3}$ Rocket: $\frac{1}{2}$ Graduation cap: $\frac{1}{6}$ Rocket: $\frac{1}{4}$ <ul style="list-style-type: none"> Three rings: $\frac{2}{5}$ Sailboat: $\frac{2}{5}$ Graduation cap: $\frac{1}{5}$ Graduation cap: $\frac{1}{8}$ <ul style="list-style-type: none"> Three rings: $\frac{2}{7}$ Sailboat: $\frac{2}{7}$ Rocket: $\frac{3}{7}$ <p>Set 2</p>

Name:

Register Number:

Class:



NAN CHIAU HIGH SCHOOL
PRELIMINARY EXAMINATION 2021
SECONDARY FOUR EXPRESS

For Marker's Use
100

Parent's Signature: _____

MATHEMATICS

4048/02

Paper 2

20 August 2021, Friday

Candidates answer on the Question Paper.

2 hours 30 minutes

READ THESE INSTRUCTIONS FIRST

- Write your name, class and index number on all the work you hand in.
- Write in dark blue or black pen.
- You may use a HB pencil for any diagrams or graphs.
- Do not use staples, paper clips, glue or correction fluid.

Answer **all** questions.

If working is needed for any question it must be shown with the answer.

Omission of essential working will result in loss of marks.

The use of an approved scientific calculator is expected, where appropriate.

If the degree of accuracy is not specified in the question, and if the answer is not exact, give the answer to three significant figures. Give answers in degrees to one decimal place.

For π , use either your calculator value or 3.142, unless the question requires the answer in terms of π .

The number of marks is given in brackets [] at the end of each question or part question. The total marks for this paper is 100.

Mathematical Formulae*Compound interest*

$$\text{Total amount} = P \left(1 + \frac{r}{100} \right)^n$$

Mensuration

$$\text{Curved surface area of a cone} = \pi r l$$

$$\text{Surface area of a sphere} = 4\pi r^2$$

$$\text{Volume of a cone} = \frac{1}{3} \pi r^2 h$$

$$\text{Volume of a sphere} = \frac{4}{3} \pi r^3$$

$$\text{Area of triangle } ABC = \frac{1}{2} ab \sin C$$

$$\text{Arc length} = r\theta, \text{ where } \theta \text{ is in radians}$$

$$\text{Sector area} = \frac{1}{2} r^2 \theta, \text{ where } \theta \text{ is in radians}$$

Trigonometry

$$\frac{a}{\sin A} = \frac{b}{\sin B} = \frac{c}{\sin C}$$

$$a^2 = b^2 + c^2 - 2bc \cos A$$

Statistics

$$\text{Mean} = \frac{\Sigma fx}{\Sigma f}$$

$$\text{Standard deviation} = \sqrt{\frac{\Sigma fx^2}{\Sigma f} - \left(\frac{\Sigma fx}{\Sigma f} \right)^2}$$

Answer all questions.

- 1 (a) Given that $a = \sqrt{\frac{b^2 + 4ac}{2a}}$, find the values of b when $a = 4$ and $c = -1$.

Answer $b = \dots\dots\dots$ [2]

- (b) Simplify $\left(\frac{125p^6}{q^{-3}}\right)^{-\frac{1}{3}} \times \left(\frac{3p^0}{\sqrt{q}}\right)^2$, leaving your answer in positive index.

Answer $\dots\dots\dots$ [2]

- (c) Solve the simultaneous equations.

$$2x - 3y = -15$$

$$0.6x + 1.5y = 6$$

Answer $x = \dots\dots\dots$ [3]

$y = \dots\dots\dots$

- (d) Express $\frac{6}{1-9x^2} + \frac{17}{6x^2+13x-5}$ as a single fraction in its simplest form.

Answer [4]

- (e) (i) Express $x^2 - 7x + 13.25$ in the form $(x - p)^2 + q$.

Answer [2]

- (ii) Hence, explain why the equation $k = x^2 - 7x + 13.25$ does not have solutions for some values of k .

Answer

.....
 [1]

- 2 (a) A sheet of rectangular paper has length l cm and breadth b cm.

If identical squares of side 3 cm are to be cut out from this rectangular paper, there will not be any leftovers.

If we rearrange some of these identical rectangular papers to form a square, the smallest possible square formed will have side 30 cm.

Given that both l and b are greater than 3 cm and $l > b$, find the values of l and b .

Answer $l = \dots\dots\dots$ [3]

$b = \dots\dots\dots$

- (b) The time taken by Shayne to swim a lap is 40% more than the time taken by Kai. Is it true that the time taken by Kai was 60% of the time by Shayne? Explain your answers with appropriate workings.

.....
..... [2]

- (c) A sweet drink is made by mixing concentrated syrup and water together.
The ratio of syrup to water in a 200 ml sweet drink is 9 : 11.
Find the volume of water that must be added to the 200 ml sweet drink so that the percentage concentration of syrup will be reduced by 10%.

Answer ml [4]

- 3 (a) Mr Lee and his wife are going for a family trip to Thailand. The table shows the travel insurance premiums payable for individual and family coverage.

Travel Insurance Premiums	Individual Policy	Family Policy (For 2 adults and up to 2 children)
• Fixed price for first 3 days	\$34	\$75 Limited offer: 20% discount for travel duration within 3 days
• Each subsequent day	\$8	\$15

If Mr Lee's family trip last for n days, find the possible values of n if the total travel insurance premium for Mr Lee's family is cheaper for individual policy than the family policy.

Answer $n = \dots\dots\dots$ [4]

- (b) Before Mr Lee travelled, he exchanged a total of Singapore dollars (SGD) \$1000 at a money changer in Singapore. The exchange rate was shown below.

Unit	Currency	Sell	Buy
100	Thai baht	4.2194	3.5002

During the trip, they spent a total of 19836 Thai baht.

Mr Lee exchanged their remaining Thai baht to SGD from the same money changer when he returned back to Singapore. Calculate the amount of money he received in SGD.

Answer SGD \$ [3]

- (c) The personal income tax is a tax levied on the annual chargeable income of working adults by the government. In Singapore, the personal income tax rates for resident taxpayers are progressive, thus the higher the chargeable income, the higher is the tax rate and the more one will need to pay. The table below shows part of the income tax rates in Singapore.

Chargeable income	Income tax rate (%)	Gross tax payable (\$)
First \$20 000	0	0
Next \$10 000	2	200
First \$30 000	-	200
Next \$10 000	3.5	350
First \$40 000	-	550
Next \$40 000	7	2 800
First \$80 000	-	3 350
Next \$40 000	11.5	4 600
First \$120 000	-	7 950
Next \$40 000	15	6 000
First \$160 000	-	13 950
Next \$40 000	18	7 200
First \$200 000	-	21 150
Next \$40 000	19	7 600

Mr Lee is married and stays with both his parents. He was entitled to the following tax deductions:

Earned income relief	\$1000
Spouse relief	\$2000
Parent relief	\$9000 per parent
CPF contribution	20% of gross income

Given that chargeable income refers to gross annual income less tax deductions, calculate his gross annual income if his income tax payable is \$9567.

Answer \$ [5]

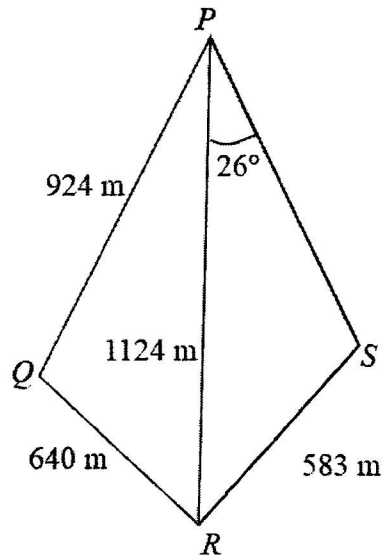

P , Q , R and S are four villages located on an island, where Q is due north of R .
 $PQ = 924$ m, $QR = 640$ m, $PR = 1124$ m, $RS = 583$ m.
 Angle $RPS = 26^\circ$ and angle PSR is obtuse.

(a) Show that P is due east of Q .

Answer

- (b) Find the bearing of S from R .

Answer ° [4]

- (c) A villager took the shortest route to jog from Village Q to Village S at a constant speed of 9.5 km/h. Find the time taken by the villager to jog from Village Q to Village S . Give your answers in minutes and seconds, correct to the nearest ten seconds.

Answer min s [4]

- 5 (a) Complete the table for $y = 9x^3 + 5x^2 - 3x + 1$.
Give your answer correct to 1 decimal place.

x	-1	-0.75	-0.5	-0.25	0	0.25	0.5	0.75	1.0
y	0	2.3	2.6		1	0.7	1.9	5.4	12

[1]

- (b) On the grid, draw the graph of $y = 9x^3 + 5x^2 - 3x + 1$ for $-1 \leq x \leq 1$.

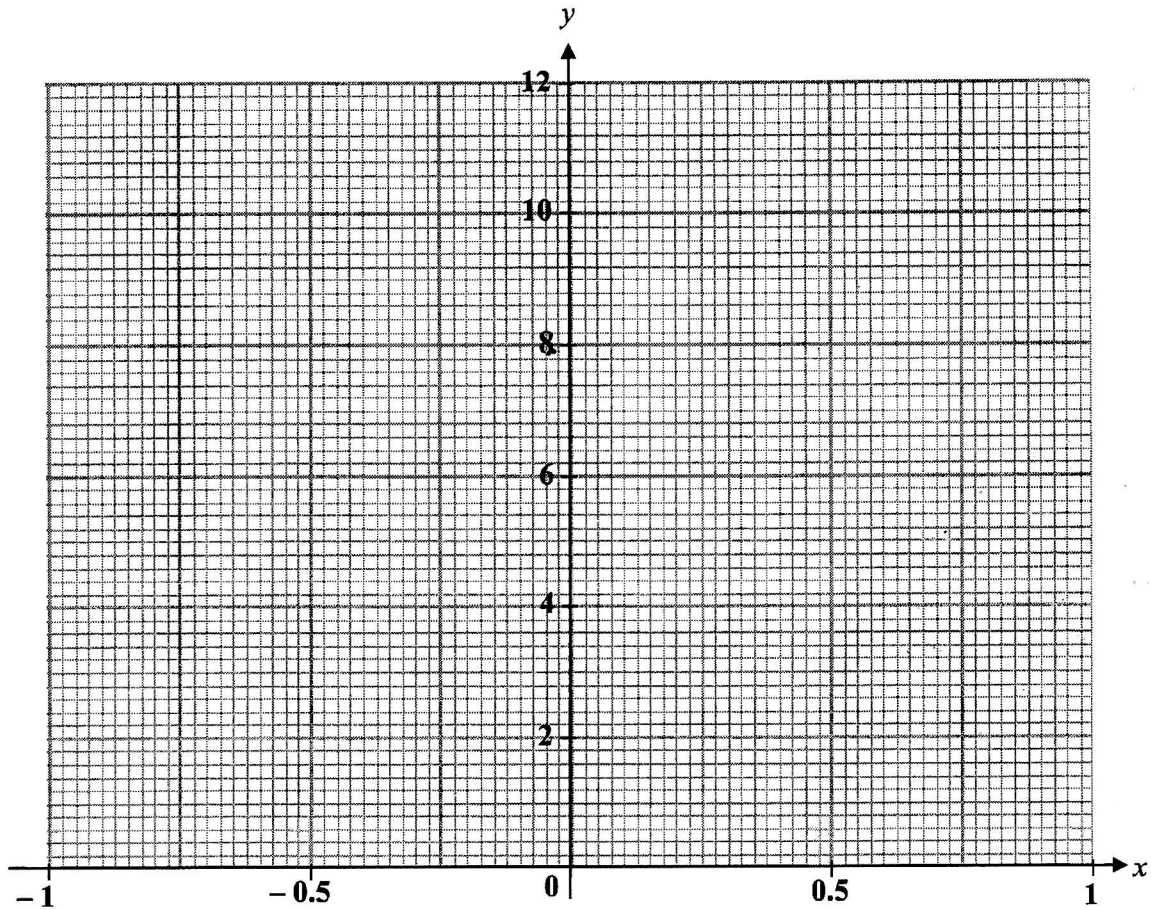

[3]

- (c) Use your graph to find the solution of the equation $9x^3 + 5x^2 = 3x + 5$.

Answer $x = \dots\dots\dots$ [2]

(d) Use your graph, find the x -coordinates of the points where the gradients are -3 .

Answer $x = \dots\dots\dots$ and $\dots\dots\dots$ [3]

(e) (i) On the grid in part (b), draw the line $8x = 5y - 15$ for $-1 \leq x \leq 1$.

[1]

(ii) The x -coordinates of the points of intersection of the line $8x = 5y - 15$ and the curve $y = 9x^3 + 5x^2 - 3x + 1$ give the solutions of the equation $45x^3 + 25x^2 - Ax - 2B = 0$. Find the values of A and B .

Answer $A = \dots\dots\dots$ [3]

$B = \dots\dots\dots$

6

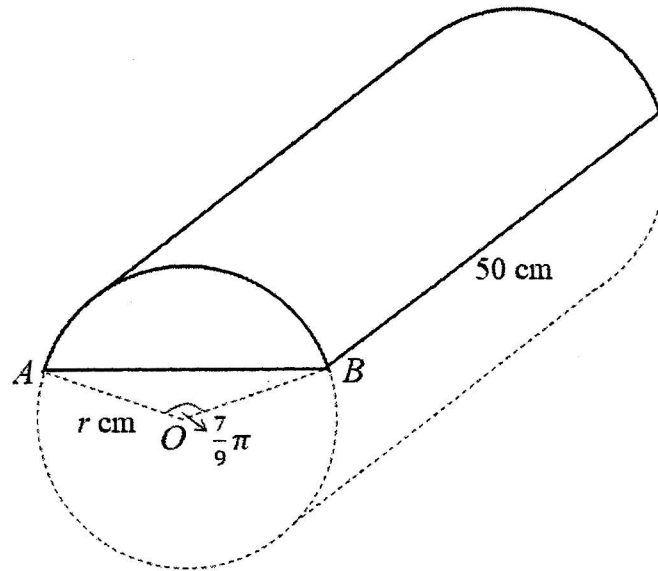

A piece of wood which was 50 cm long, was in the shape of a uniform cylinder. A prism is cut out from the wood such that its cross-section is a minor segment of a circle, with centre O , radius r cm and $\angle AOB = \frac{7}{9}\pi$ radians.

- (a) Given that the area of the minor segment is $3 \times 10^{-3} \text{ m}^2$, show that $r = 5.772$, correct to 3 decimal places.

Answer

- (b) Sally would like to use a roll of 2 m long ribbon to beautify the outline of the prism by using it to paste on all the six edges. Determine if there is sufficient ribbon.

.....

..... [4]

- 7 $ABCD$ is a parallelogram.
 Point A lies on the y -axis and coordinates of D is $(6, -1)$.
 AC is a horizontal line and gradient of $BC = -\frac{4}{3}$.

(a) Find the coordinates of A .

Answer A (.....,) [2]

(b) Find the length of BC .

Answerunits [2]

(c) Given that gradient of AB is 0.8, find the coordinates of C .

Answer C (.....,) [2]

(d) Find the area of the parallelogram.

Answerunits² [2]

- 8 Nurul took 2.5 hours to travel at a constant speed from Town *A* to *B*.
On her journey back, she increased her constant speed by 4 km/h and took 15 minutes less.

(a) Show that her travelling speed from Town *A* to *B* is 36 km/h.

Answer

[2]

(b) Find the average speed for her whole journey from Town *A* to *B* and back to Town *A*, assuming she did not stop during her journey.

Answer km/h [2]

(c) On the grid below, draw the distance-time graph of her whole journey from Town *A* to *B* and back to Town *A*.

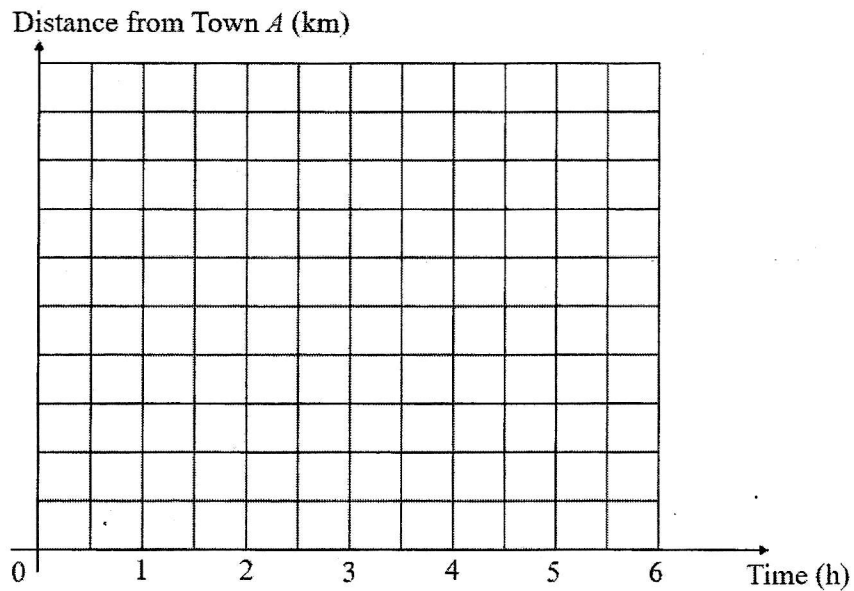

[2]

9 (a)

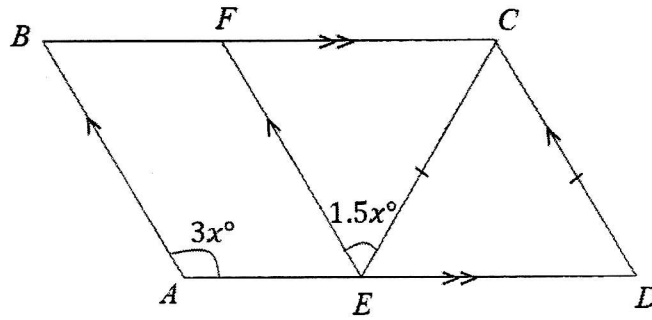

$ABCD$ is a parallelogram and triangle CDE is isosceles.
 E and F are points on AD and BC respectively.
 AB , EF and CD are parallel lines.
 Angle $BAE = 3x^\circ$ and angle $CEF = 1.5x^\circ$.

Find the value of x . State your reasons clearly.

Answer $x = \dots\dots\dots$ [3]

- (b) The ratio of an interior angle of a regular n -sided polygon to an interior angle of a regular $(n + 2)$ -sided polygon is $15 : 16$. Find the value of n .

Continuation of working space for question 9(b)

Answer $n = \dots\dots\dots$ [3]

(c)

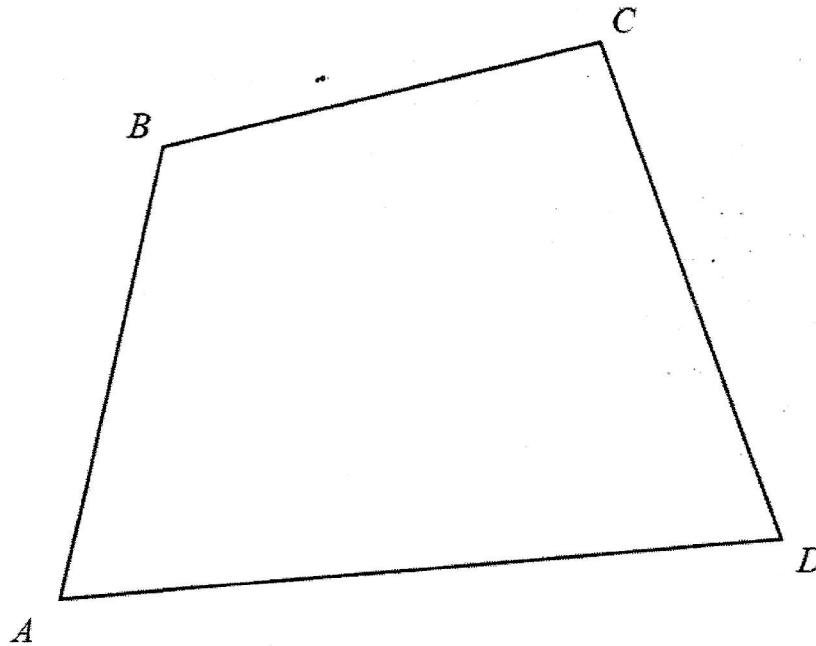

$ABCD$ is a plot of a garden.

A playground, P , was planned to be built in this garden, equidistant from side AB and BC , and equidistant between point A and point D .

By construction, mark the position of P .

[3]

10 Karen is selling pancakes for a one-day charity event.

She specialises in three different types of pancakes which are plain, chocolate and cheese at the cost of \$2, \$3 and \$4 each respectively.

The matrix **A** shows the average number of pancakes sold in the morning and afternoon of the day.

$$A = \begin{matrix} & \begin{matrix} \text{Plain} & \text{Chocolate} & \text{Cheese} \end{matrix} \\ \begin{pmatrix} 83 & 86 & 72 \\ 46 & 67 & 47 \end{pmatrix} & \begin{matrix} \text{Morning} \\ \text{Afternoon} \end{matrix} \end{matrix}$$

The necessary ingredients for the pancakes recipe are shown below.

Ingredients (12 servings)	
Basic (plain)	<ul style="list-style-type: none"> • 2 large eggs • 500 ml of milk • 255g of self-raising flour
Add on	<ul style="list-style-type: none"> • 60 g of cocoa powder for chocolate pancakes • 100 g cream cheese for cheese pancakes

The price for each ingredient are such that:

Ingredient	Packaging	Unit Price	Bundle price
Eggs	1 tray of 30	\$6	–
Milk	1 litre carton	\$3.50	Buy 2 for \$5.95
Self-raising flour	1 kg packet	\$2.50	–
Cocoa powder	1 kg tin	\$13.50	–
Cream cheese	1 kg block	\$15.50	–

(a) (i) Evaluate the matrix $T = (1 \ 1)A$.

Answer [1]

(ii) State what each element of matrix **T** represents.

.....
[1]

(iii) Using matrix multiplication, find the total revenue from the sales.

Answer \$..... [2]

- (b) Given that all profit earned from this charity event will be donated to the Voluntary Welfare Organisation, is it true that her donation is more than 900% of her cost price? Justify your answer and show all your workings clearly.

..... [7]

End of paper



P2

NAN CHIAM

22

Answer Key

1a	$b = \pm 12$
1b	$\frac{9}{5p^2q^2}$
1c	$x = -\frac{15}{16}, y = \frac{35}{8}$
1d	$\frac{13}{(1+3x)(2x+5)}$
1ei	$(x - 3.5)^2 + 1$
1eii	<p>Since the minimum point is (3.5, 1), any $k < 1$ will not have any solutions.</p> <p>or</p> <p>Since the minimum value is 1, hence for any $k < 1$ will not have any solutions.</p> <p>or</p> <p>Since $(x - 3.5)^2 \geq 0, k - 1 \geq 0, k \geq 1$.</p>
2a	<p>$l = 15, b = 6$</p> <p>or $l = 30, b = 6$</p> <p>or $l = 30, b = 15$</p>
2b	<p>$S = 1.4K$ which implies $\frac{5}{7}S = K$.</p> <p>Hence, $\frac{5}{7} \times 100\% = 71\frac{3}{7}\% \neq 60\%$.</p> <p>Hence it is not true.</p> <p>or</p> <p>Let t be the time taken by Kai.</p> <p>Hence time taken by Shayne is $1.4t$.</p> <p>$0.6 \times 1.4t = 0.84t \neq t$</p> <p>or $\frac{t}{1.4t} \times 100\% = 71.4\% \neq 60\%$</p> <p>Hence it is not true.</p>
2c	$x = 22.2 \text{ ml or } 22\frac{2}{9} \text{ ml}$
3a	$n = 4, 5, 6, 7, 8, 9$
3b	\$135.25
3c	$x = \$189\,725$

4a	<p>$1124^2 = 640^2 + 924^2 -$ $2(640)(924) \cos \angle PQR$ $\cos \angle PQR = 0$ $\angle PQR = 90^\circ$</p> <p>Thus, P is due east of Q.</p> <p>Or</p> <p>$PQ^2 + QR^2 = 924^2 + 640^2 = 12363376$ $PR^2 = 1124^2 = 12363376$</p> <p>Since $PQ^2 + QR^2 = PR^2$, by converse of Pythagoras' Theorem, $\angle PQR = 90^\circ$.</p> <p>Hence, P is due east of Q.</p> <p>(Do not assume $PQ^2 + QR^2 = PR^2$ and write it as your first step.)</p>
4b	087.0°
4c	5 min 20 s
5a	1.9
5b	Refer to the last page.
5c	$x = 0.775$
5d	$x = 0$ or $x = -0.37$
5ei	Refer to the last page.
5eii	$A = 23, B = 5$
6a	Shown
6b	<p>Edge Perimeter = 49.72 cm</p> <p>Since $149.72 < 2$, there are sufficient ribbon.</p>
7a	$A(0, 7)$
7b	10
7c	$C(16, 7)$
7d	128
8a	$x = 36$
8b	$37\frac{17}{19}$ or 37.9

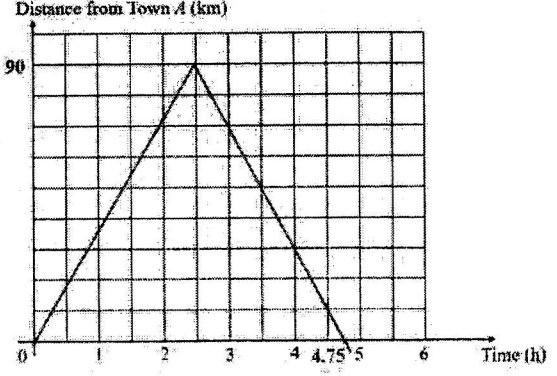
<p>8c</p>	
<p>9a</p>	<p>$x = 40$</p>
<p>9b</p>	<p>$n = 8$ (as $n > 0$)</p>
<p>10ai</p>	<p>(129 153 119)</p>
<p>10aii</p>	<p>It represents the respective number of plain, chocolate and cheese pancakes sold that day.</p>

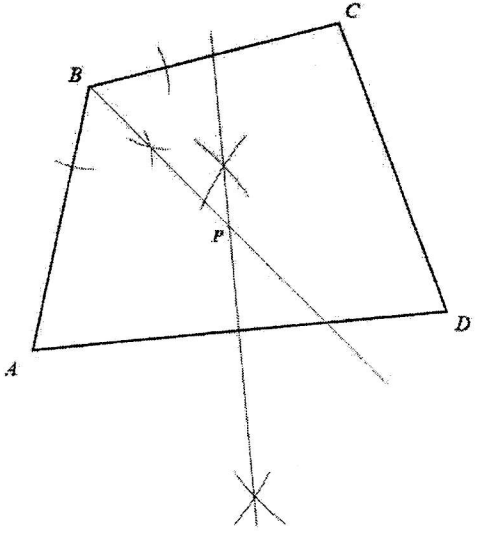
<p>9c</p>	
<p>10aiii</p>	<p>\$1193</p>
<p>10b</p>	<p>Since $889\% < 900\%$, it is not true.</p>

Q5b, 5ei

