

Visit

FREETESTPAPER.com

for more papers



Website: [freetestpaper.com](http://www.freetestpaper.com)



[Facebook.com/freetestpaper](https://www.facebook.com/freetestpaper)



[Twitter.com/freetestpaper](https://www.twitter.com/freetestpaper)

Name		Index Number		Class	
------	--	--------------	--	-------	--

ST. ANTHONY'S CANOSSIAN SECONDARY SCHOOL
Preliminary Examination 2023
Secondary 4 Express

MATHEMATICS**4052/01**

Paper 1

22 August 2023

Setter: Mdm Bey Young Keng

2 hours 15 minutes



Candidates answer on the Question Paper.

READ THESE INSTRUCTIONS FIRST

Write your name, index number and class on all the work you hand in.

Write in dark blue or black pen.

You may use an HB pencil for any diagrams or graphs.

Do not use staples, paper clips, glue or correction fluid.

Answer **all** questions.

If working is needed for any question it must be shown with the answer.

Omission of essential working will result in loss of marks.

The use of an approved scientific calculator is expected, where appropriate.

If the degree of accuracy is not specified in the question, and if the answer is not exact, give the answer to three significant figures. Give answers in degrees to one decimal place.

For π , use either your calculator value or 3.142, unless the question requires the answer in terms of π .

The number of marks is given in brackets [] at the end of each question or part question.

The total number of marks for this paper is 90.

90

Parent's Signature:

This document consists of **23** printed pages.**Turn over**

Answer **all** the questions.

1 (a) Calculate $\frac{282.334 - \sqrt{50.1}}{3.12 \times 5.97}$.

Write down the first five digits of your answer.

Answer [1]

(b) Write your answer to **part (a)** correct to 2 significant figures.

Answer [1]

2 Expand and simplify $3(5a - 2) - (8 - 4a)$.

Answer [2]

3 The equation $3 - \frac{x}{4} = \frac{2(x-2)}{3}$ can be rewritten as $Ax + B = 0$ where $A > B$.
Find the value of A and the value of B .

Answer $A = \dots\dots\dots$, $B = \dots\dots\dots$ [2]

- 4 The line graph shows the number of patients in a hospital who are diagnosed with a certain type of blood disorder over the years.

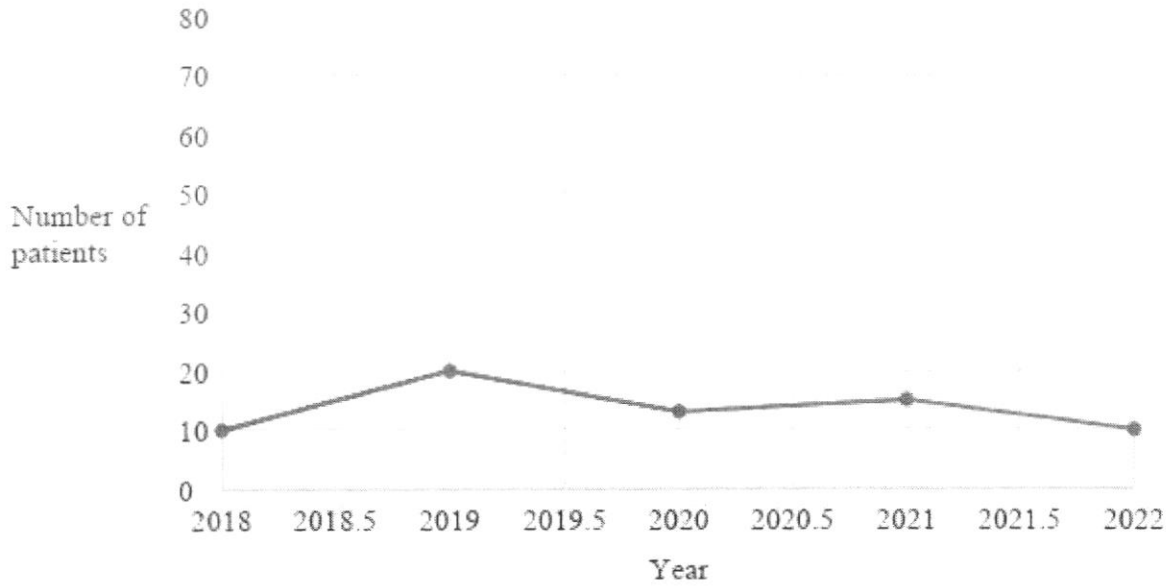

- (a) Calculate the percentage increase in the number of patients diagnosed with the blood disorder from 2018 to 2019.

Answer % [1]

- (b) State and explain one aspect of the line graph that may be misleading.

.....
.....
.....
.....
.....[1]

5 (a) Express $x^2 - 6x - 16$ in the form $(x - p)^2 + q$.

Answer [1]

(b) Hence, explain why the value of $x^2 - 6x - 16$ cannot be -30 .

.....
.....
.....
.....[1]

6 (a) Express 336 as a product of its prime factors.

Answer $336 = \dots\dots\dots$ [1]

(b) Given that $1764 = 2^2 \times 3^2 \times 7^2$,

(i) express the smallest integer which is a multiple of 336 and 1764 as a product of its prime factors,

Answer [1]

(ii) find the smallest positive integer value of n such that $\frac{1764n}{336}$ is a perfect square.

Answer $n = \dots\dots\dots$ [1]

- 7 The diagram shows a plot of land $ABCD$ with a house in one corner.

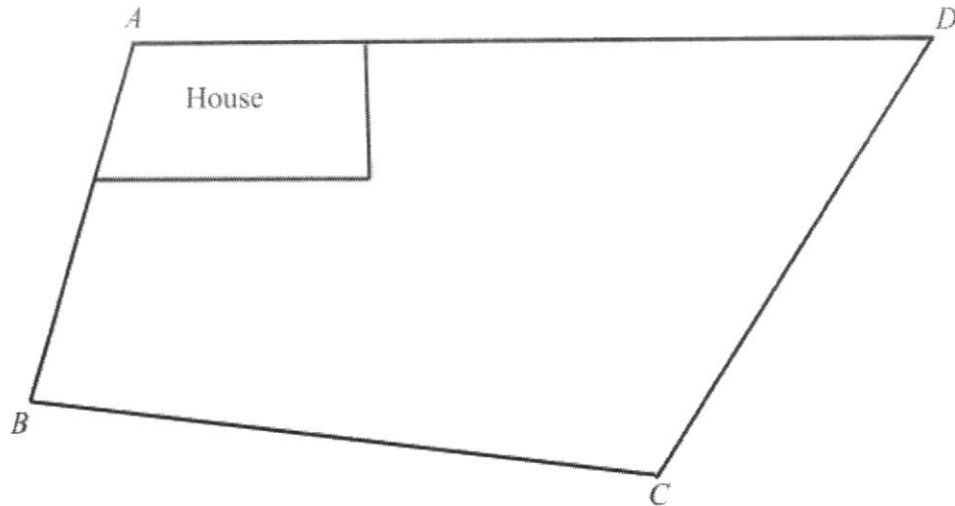

- (a) On the diagram, construct
- (i) the perpendicular bisector of BC . [1]
 - (ii) the bisector of angle BAD . [1]
- [1]
- (b) A tree is to be planted nearer to AB than AD and nearer to B than C .
Shade the region representing the area in which the tree can be planted. [1]

- 8 The table below shows the number of children in 100 families living in a housing estate.

Number of children	0	1	2 or 3
Number of families	10	25	65

The mean number of children per family is 1.82.
Calculate the number of families with 2 children.

Answer[3]

- 9 The straight line $3x + 5y = 24$ cuts the x -axis and y -axis at points P and Q respectively.
Calculate the length of PQ .

Answer $PQ =$ [3]

10

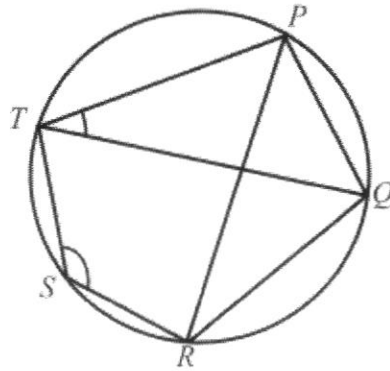

In the diagram, P, Q, R, S and T are points on the circle.

Angle $PTQ = 35^\circ$ and angle $TSR = 139^\circ$.

- (a) Find angle TPR .
Give a reason for each step of your working.

Answer Angle $TPR = \dots\dots\dots$ [1]

- (b) Explain why TP and RQ are not parallel.

.....

[2]

11 Simplify $\frac{8x-12y}{2x^2-xy-3y^2}$.

Answer [3]

12

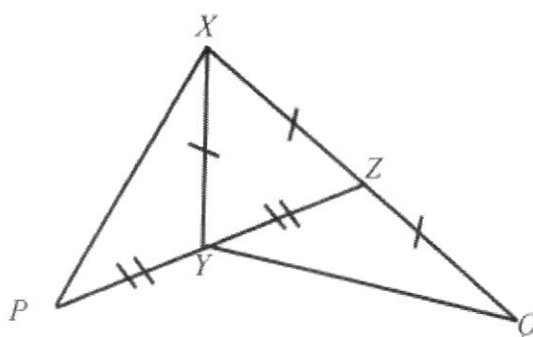

In the diagram, XYZ is an isosceles triangle with $XY = XZ$. The side XZ is produced to Q such that $XZ = ZQ$. The side ZY is produced to P such that $ZY = YP$.

(a) Name a pair of congruent triangles.

Answer Triangle.....and triangle.....[1]

(b) Show that the two triangles in (a) are congruent.

.....

.....

.....

.....

.....

.....

.....[2]

13 (a) The speed of light is 3×10^8 m/s.

Express 3×10^8 as k million.

Answermillion [1]

(b) The relationship between the wavelength and frequency of a wave is given by $c = w \times f$ where c is the speed of light, 3×10^8 m/s, w is the wavelength in metres and f is the frequency in Hertz (Hz).

(i) The wavelength of a photon particle is observed to be 500 nanometres.

[1 nanometre = 10^{-9} metres]

Express 500 nanometres in metres, leaving your answer in standard form.

Answermetres [1]

(ii) Calculate the frequency of the photon particle, leaving your answer in standard form.

AnswerHz [1]

14

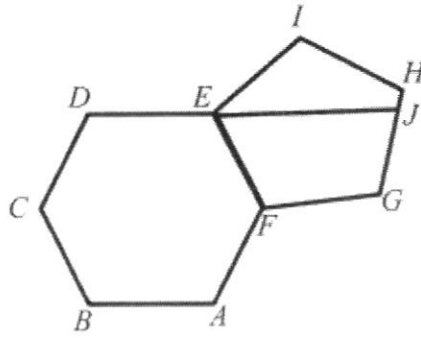

In the diagram, a regular hexagon $ABCDEF$ and a regular pentagon $EFGHI$ are joined together at the side EF .

DEJ is a straight line.

Calculate angle JEI .

Answer Angle $JEI = \dots\dots\dots [3]$

15 The diagram shows the speed-time graph of a car journey.

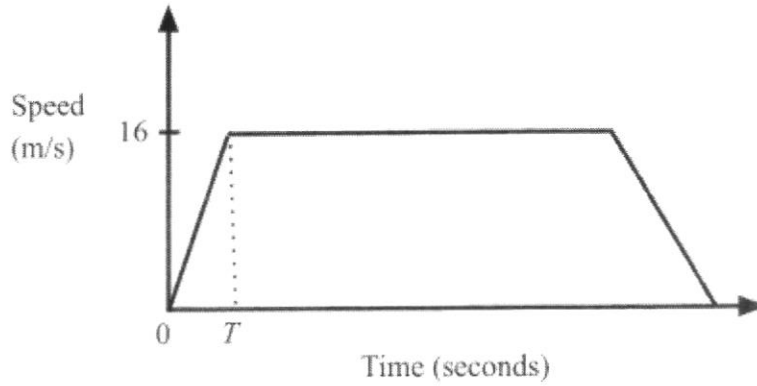

The car starts from rest and for T seconds, it accelerates at 2 m/s^2 until it reaches a speed of 16 m/s .

(a) Find the value of T .

Answer $T = \dots\dots\dots$ [1]

(b) The car then travels at 16 m/s for 40 seconds, after which the driver applies the brakes and brings the car to rest in a further 10 seconds. Calculate the average speed of the car during the last 50 seconds.

Answer $\dots\dots\dots \text{m/s}$ [2]

16 Factorise completely $8a^3 + 8a^2b - 2ab^2 - 2b^3$.

Answer [3]

17 A sum of money was shared among Jess, Lin and Kim. Kim received $\frac{2}{5}$ of the sum and the remainder was shared among Jess and Lin in the ratio 2 : 3.

If Kim received \$640 more than Jess, calculate the amount of money Lin received.

Answer \$.....[4]

18 (a) Simplify the following leaving your answer in positive index.

(i) $\sqrt[4]{81a^{\frac{5}{3}}}$,

Answer [1]

(ii) $18n^{-9} \div (3n^{-2})^2$.

Answer [2]

(b) Given that $2^7 \times 16^k = 2^k$, find the value of k .

Answer $k =$ [2]

- 19 (a)** $\xi = \{\text{students in a school}\}$
 $H = \{\text{students with heights greater than 170 cm}\}$
 $B = \{\text{students who enjoy playing basketball}\}$
 $S = \{\text{students who do not wear spectacles}\}$

(i) Express in words the meaning of $H' \cap B \neq \phi$.

.....
[1]

(ii) Express in set notation, the statement, "All students who enjoy playing basketball do not wear spectacles".

Answer [1]

- (b)** $\xi = \{x : x \text{ is an integer and } 41 \leq x \leq 54\}$
 $P = \{x : x \text{ is divisible by 3}\}$
 $Q = \{x : x \text{ is divisible by 6}\}$

(i) Find the value of $n(P)$.

Answer [1]

(ii) List the elements in the set $P \cap Q$.

Answer $P \cap Q = \dots\dots\dots$ [1]

(iii) Draw a Venn diagram to represent ξ , P and Q .

[1]

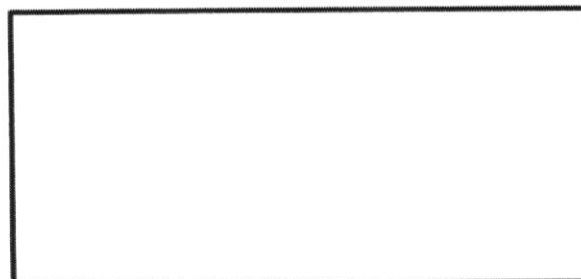

- 20 Amy, Betsy and Carol took a Mathematics examination which consists of two papers, Paper 1 and Paper 2. Their marks for Paper 1 and Paper 2 are represented by the matrix, \mathbf{S} .

$$\mathbf{S} = \begin{array}{cc} \text{Paper1} & \text{Paper 2} \\ \left(\begin{array}{cc} 64 & 70 \\ 56 & 48 \\ x & 44 \end{array} \right) & \begin{array}{l} \text{Amy} \\ \text{Betsy} \\ \text{Carol} \end{array} \end{array}$$

The mark for the subject is then computed according to the weighting shown in the table below.

	Paper 1	Paper 2
Weighting	0.625	0.5

- (a) Express the weighting using a 2×1 matrix, \mathbf{W} .

Answer $\mathbf{W} =$ [1]

- (b) Given that $\mathbf{T} = \mathbf{SW}$, find the matrix \mathbf{T} , in terms of x .

Answer $\mathbf{T} =$ [1]

- (c) Carol scores 42 marks after computation of her marks for both papers based on the weighting.

- (i) Find the value of x .

Answer $x = \dots\dots\dots$ [1]

(ii) Given that $\mathbf{R} = \begin{pmatrix} 1 & 1 & 1 \end{pmatrix}$ evaluate the matrix, $\mathbf{D} = \frac{1}{3}\mathbf{RT}$.

Answer $\mathbf{D} = \dots\dots\dots$ [1]

(iii) State what the matrix \mathbf{D} represents.

.....
[1]

21

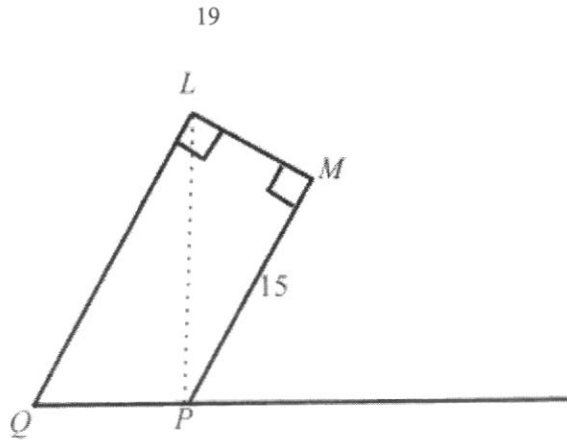

$LMPQ$ represents a sculpture resting on level ground. The point P is vertically below L .
 $MP = 15$ m and angle $PML = \text{angle } QLM = 90^\circ$. The angle of depression of M from L is 30° .
 Calculate the difference in the vertical height of L and M from the ground.

Answerm [5]

22 The times taken for 20 people to clear the customs at the checkpoint on a weekday were recorded. The results are shown in the stem-and-leaf diagram below.



Key: 2 | 4 represents 24 minutes

(a) Write down the mode.

Answer.....minutes [1]

(b) Find the upper quartile.

Answer.....minutes [1]

(c) Calculate

(i) the mean time,

Answerminutes [1]

(ii) the standard deviation.

Answerminutes [1]

(d) The standard deviation of times taken by another group of people to clear the customs at the same checkpoint on a weekend was 11.5 minutes.

Comment on the times taken by the two groups of people to clear the customs.

.....

.....

.....

.....

.....

.....[1]

23

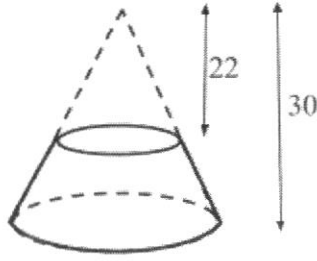

The diagram shows a cone with a height of 30 cm and a smaller cone with a height of 22 cm.

The volume of the bigger cone is $\frac{1000}{3} \text{ cm}^3$.

The small cone is removed from the top of the bigger cone. The diagram shows the solid remaining with a remaining slant height of x cm.

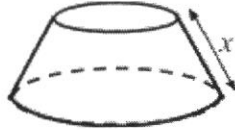

(a) By using similar triangles, express the slant height of the smaller cone in terms of x .

Answer [2]

(b) Calculate the volume of the remaining solid.

Answercm³ [4]

24 The table shows part of a pattern of consecutive odd integers being added.

Row	Mathematical sentence	Sum	Number of odd integers added
1	1 + 3	4	2
2	1 + 3 + 5	9	3
3	1 + 3 + 5 + 7	16	4
4	1 + 3 + 5 + 7 + 9	25	5
...
n	$1 + 3 + 5 + 7 + 9 + \dots + k$	S	

(a) Complete the table below for Row 6.

Answer

Row	Mathematical sentence	Sum	Number of odd integers added
6			

[1]

(b) Explain why 200 cannot be a value in the column for the sum.

.....
[1]

(c) Find an expression, in terms of n , for

(i) k ,

Answer $k = \dots\dots\dots$ [1]

(ii) S .

Answer $S = \dots\dots\dots$ [1]

(d) In a certain row, the sum of odd integers is 1024.
 Find the number of odd integers that are added in that row.

Answer [2]

25 (a)

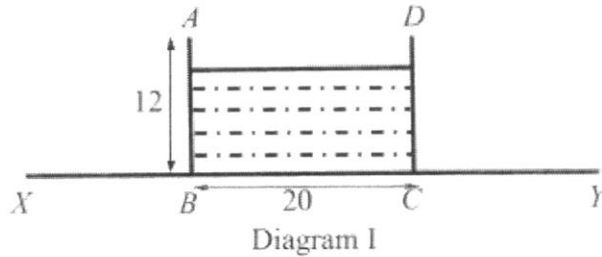
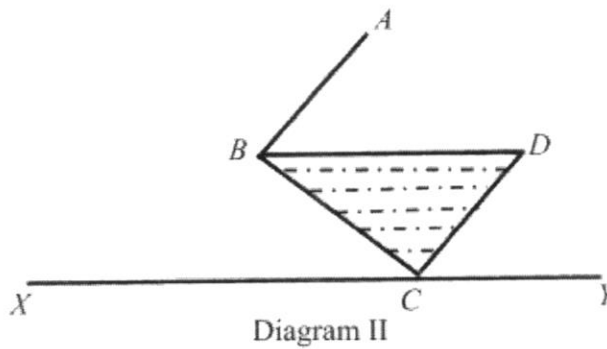

Diagram I shows a vertical cross section of a rectangular tank which stands on a horizontal table represented by XY . The tank has a height of 12 cm and a square base of side 20 cm. The tank is filled with some water.

The tank is then tilted about the edge through C so that some water spills out. The tank is tilted until a position as shown in Diagram II.



Calculate the volume of water remaining in the tank as shown in Diagram II.

Answercm³ [2]

- (b) The water remaining in the tank is then poured into a hemispherical bowl. When the tank is fully emptied, the hemispherical bowl is filled completely to the brim.
- (i) Calculate the radius of the hemispherical bowl.

Answercm [2]

- (ii) When the water is filled up to a depth of d cm, the radius of the horizontal water surface in the hemispherical bowl is 7 cm as shown in Diagram III.

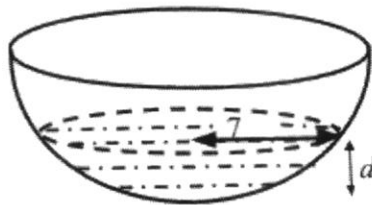

Diagram III

Calculate the value of d .

Answer $d =$ cm [2]

Name		Index Number		Class	
------	--	--------------	--	-------	--

ST. ANTHONY'S CANOSSIAN SECONDARY SCHOOL
Preliminary Examination 2023
Secondary 4 Express

Mathematics**4052/02**

Paper 2

28 August 2023

Setter: Mdm Bey Young Keng

2 hours 15 minutes



Candidates answer on the Question Paper.

READ THESE INSTRUCTIONS FIRST

Write your name, index number and class in the spaces at the top of this page.

Write in dark blue or black pen.

You may use an HB pencil for any diagrams or graphs.

Do not use staples, paper clips, glue or correction fluid.

Answer **all** questions.

If working is needed for any question it must be shown with the answer.

Omission of essential working will result in loss of marks.

The use of an approved scientific calculator is expected, where appropriate.

If the degree of accuracy is not specified in the question, and if the answer is not exact, give the answer to three significant figures. Give answers in degrees to one decimal place.

For π , use either your calculator value or 3.142, unless the question requires the answer in terms of π .

At the end of the examination, fasten all your work securely together.

The number of marks is given in brackets [] at the end of each question or part question.

The total number of marks for this paper is 90.

90
Parent's signature:

This document consists of **23** printed pages.**[Turn over**

Answer **all** the questions.

1 (a) It is given that $m = \sqrt[3]{\frac{5v - 4c^2}{v - 6}}$.

- (i) Find the value of m when $v = 3$ and $c = \frac{1}{2}$.

Answer $m = \dots\dots\dots$ [1]

- (ii) Express v in terms of c and m .

Answer $v = \dots\dots\dots$ [3]

- (b) Solve the simultaneous equations.

$$2x + 5y = 25$$

$$3x - 2y = 9$$

You must show your working.

Answer $x = \dots\dots\dots$
 $y = \dots\dots\dots$ [3]

- (c) Write as a single fraction in its simplest form $\frac{2}{(3x-2)^2} - \frac{1}{2-3x}$.

Answer $\dots\dots\dots$ [2]

- (d) Solve the equation $2x-5 = \frac{15}{x-2}$.

Answer $x = \dots\dots\dots$ or $x = \dots\dots\dots$ [3]

-
- 2 Bala and Clement each decided to buy a new car. The cash price of the new car was \$172 000.
- (a) Bala bought the new car on a hire purchase scheme. He paid 30% of the cash price as a deposit followed by instalments of \$3 825 per month over a period of 3 years.
- Calculate
- (i) the total amount of money Bala paid for the new car.

Answer \$..... [2]

- (ii) the extra cost of buying the car by hire purchase as a percentage of the cash price.

Answer% [2]

- (b) Clement also paid 30% of the cash price as a deposit. He then borrowed the remaining amount for 5 years at an interest rate of 4% per year compounded twice yearly.
- Calculate the total amount of interest Clement has to pay for 5 years.

Answer \$..... [4]

- (c) The exchange rate of Singapore Dollars (S\$) and Malaysian Ringgit (RM) is S\$1 = RM3.32. The same car is sold in Malaysia for RM 328 416.
Calculate the difference in cash price of the car, in Singapore Dollars.

Answer S\$..... [2]

- 3 The variables x and y are connected by the equation $y = \frac{x^2}{5} + \frac{12}{x} - 4$.

Some corresponding values of x and y are given in the table below.

x	1	1.5	2	3	4	5	6	7
y	8	4.5	2.8	1.8	p	3.4	5.2	7.5

- (a) Find the value of p .

Answer $p = \dots\dots\dots$ [1]

- (b) On the grid opposite, draw the graph of $y = \frac{x^2}{5} + \frac{12}{x} - 4$ for $1 \leq x \leq 7$.
[3]

- (c) Explain why your graph shows that there is no solution for $\frac{x^2}{5} + \frac{12}{x} - 5 = 0$.
.....
.....
.....[1]

- (d) (i) On the same axes, draw the line $2y + x = 10$ for $1 \leq x \leq 7$.
[1]

- (ii) Write down the x -coordinates of the points of intersection of the line $2y + x = 10$ and the curve.

Answer $x = \dots\dots\dots$ or $\dots\dots\dots$ [2]

- (iii) The values of x in **d(ii)** are the solutions of a cubic equation, $ax^3 + bx^2 + cx + d = 0$ where a, b, c and d are integers. Find this cubic equation.

Answer [2]

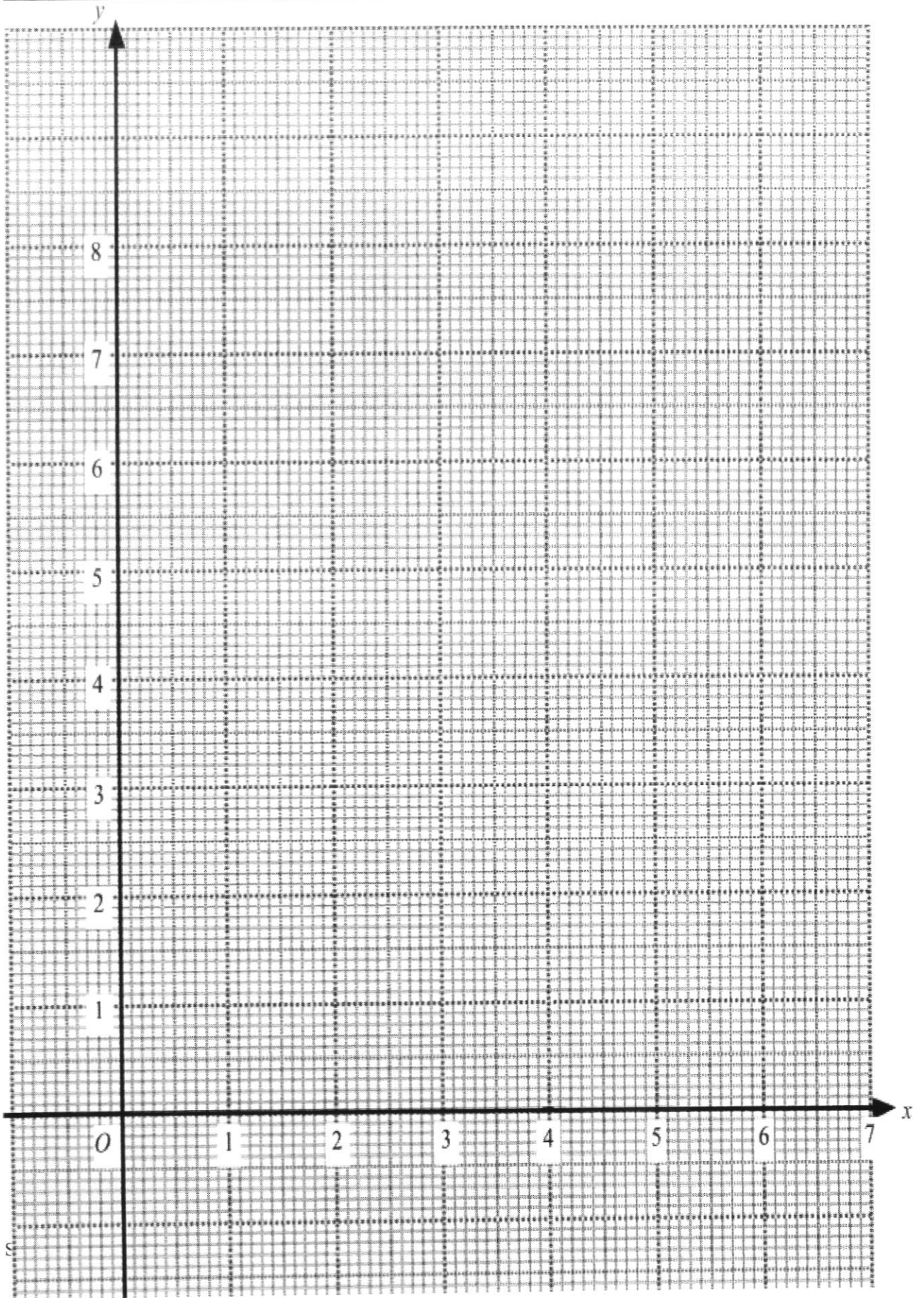

(b) Given that $AC = 10$ cm, $BY = 4.81$ cm and angle $CAY = 0.663$ radians,

(i) calculate the area of triangle CBY ,

Answercm² [3]

(ii) calculate the area of the shaded region.

Answercm² [4]

- 5 (a) P is the point $(4, -3)$ and $\overrightarrow{PQ} = \begin{pmatrix} -9 \\ 4 \end{pmatrix}$.

(i) Find $|\overrightarrow{OQ}|$.

Answer $|\overrightarrow{OQ}| = \dots\dots\dots$ units [2]

(ii) Find the equation of the line PQ .

Answer $\dots\dots\dots$ [2]

(b)

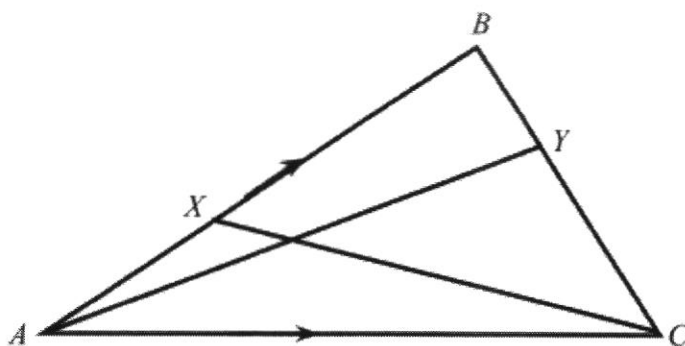

The diagram shows a triangle ABC . X is a point on AB and Y is a point on BC such that $AX : XB = 2 : 3$ and $BY : YC = 1 : 2$.

$\overrightarrow{AB} = \mathbf{p}$ and $\overrightarrow{AC} = \mathbf{q}$.

(i) Express \overrightarrow{CB} in terms of \mathbf{p} and \mathbf{q} , as simply as possible.

Answer $\overrightarrow{CB} = \dots\dots\dots$ [1]

(ii) Express \overrightarrow{XY} in terms of \mathbf{p} and \mathbf{q} , as simply as possible.

Answer $\overrightarrow{XY} = \dots\dots\dots$ [3]

(iii) Find the area of triangle XBC if the area of triangle $ABC = 30 \text{ cm}^2$.

Answer $\dots\dots\dots\text{cm}^2$ [1]

(iv) If $\overrightarrow{XM} = \frac{2}{15}\mathbf{p} + \frac{1}{6}\mathbf{q}$, explain why X , Y and M are collinear points.

.....
.....
.....
.....
.....[2]

6

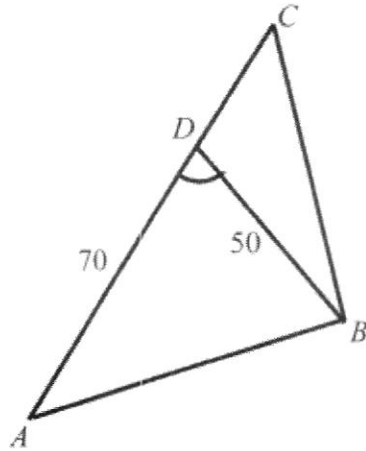

Points A , B , C and D lie on level ground. ADC is a straight line and $AD = 70$ m. $BD = 50$ m and angle $ADB = 62^\circ$. The point A is on a bearing of 220° from C .

Calculate

(a) the bearing of C from A ,

Answer [1]

(b) AB ,

Answerm [3]

(c) the bearing of B from A .

Answer [3]

17

7

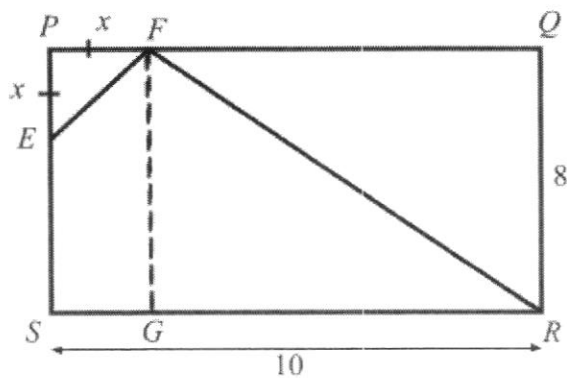

In the diagram, $PQRS$ is a rectangle where $QR = 8$ cm, $RS = 10$ cm and $PE = PF = x$ cm. G is a point on RS such that FG is parallel to ES .

(a) The area of the shaded quadrilateral $EFRS$ is 47 cm².

Form an equation in x and show that it simplifies to $x^2 - 8x + 14 = 0$.

[5]

- (b) Solve the equation $x^2 - 8x + 14 = 0$, giving your solutions correct to two decimal places.

Answer $x = \dots\dots\dots$ or $x = \dots\dots\dots$ [4]

- (c) Hence, find the smallest possible value of the area of triangle FQR .

Answer $\dots\dots\dots\text{cm}^2$ [2]

- 8 (a) The speeds of 200 vehicles travelling on an expressway one morning were recorded. The cumulative frequency curve below shows the distribution of their speeds.

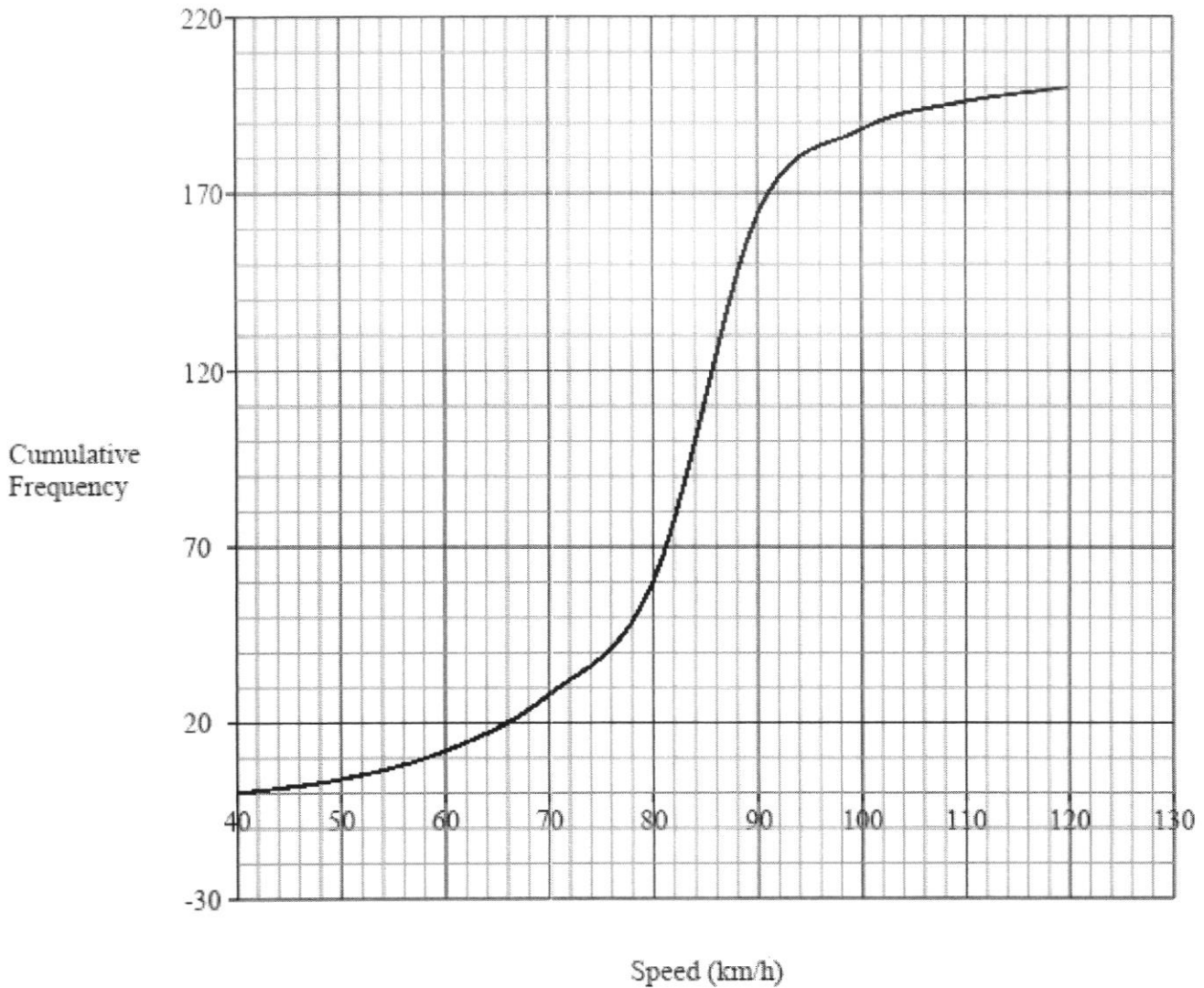

- (i) Use the curve to estimate
- (a) the median speed,

Answerkm/h [1]

- (b) the interquartile range.

Answerkm/h [2]

- (ii) The speed limit on the expressway is 90 km/h.
Calculate the percentage of vehicles travelling above the speed limit.

Answer% [2]

- (iii) A vehicle is selected at random from the 200 vehicles.

The probability that the speed of the vehicle is more than y km/h is $\frac{1}{5}$.
Find the value of y .

Answer $y =$ [1]

- (iv) Two vehicles are selected at random from the 200 vehicles.
Find the probability that only one of them travels at a speed of between 80 km/h to 100 km/h.

Answer [2]

- (b) The speeds of another 200 vehicles travelling on the same expressway in the afternoon were also recorded. The box-and-whisker plot shows the distribution of the speeds.

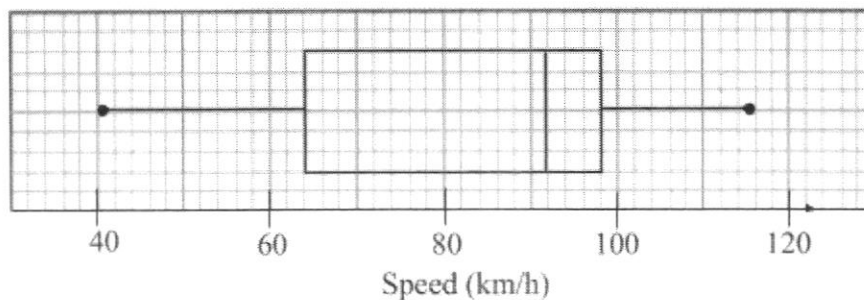

- (i) A vehicle is selected at random from these 200 vehicles.
Find the probability that the vehicle selected travels at a speed less than or equal to 64 km/h.

Answer [1]

- (ii) John said that the vehicles travelling on the expressway in the afternoon were slower than those which travel on the same expressway in the morning.
Do you agree with John?
Explain your answer.

.....

 [1]

- 9 A class is planning to bake cookies for sale during the school's fun fair. They will pack the cookies in individual paper bags and each paper bag will contain 5 cookies. The class will prepare 50 bags of cookies. The class uses the recipe for cookies as shown below.

Chocolate Chips Cookies Recipe	
(Yields 4 dozen round cookies with radius of 2 cm approximately)	
	1 cup butter, softened
	2 cups brown sugar
	3 cups all-purpose flour
$1\frac{1}{2}$	cups semi-sweet chocolate chips
$\frac{1}{2}$	teaspoon salt
	2 eggs
	2 teaspoons vanilla essence
	2 teaspoons hot water

The class needs to adjust the amount of each ingredient in the recipe so that they have enough amount of each ingredient to bake the required number of cookies. This can be done by multiplying the amount of each ingredient in the recipe by a conversion factor. For the ease of measurement of each ingredient, the class rounds up the conversion factor to the next nearest whole number and they will hence bake more cookies than required.

- (a) Calculate the conversion factor needed to make enough cookies for the fun fair.

Answer [1]

The class then proceeds to buy the materials needed using the information on the next page.

- (b) Calculate the total cost of vanilla essence they have to buy.

Conversion Chart	
Basic Baking Ingredients	
Ingredient	1 cup to grams
Butter	230 g
Flour	140 g
Brown sugar	160 g
Chocolate chips	190 g
Rolled oats	90 g
Almond flakes	90 g

Answer \$..... [2]

Conversion Chart	
Basic Baking Ingredients	
Ingredient	1 teaspoon to grams or ml
Brown sugar	4.5 g
Salt	7g
Yeast	2.8 g
Baking powder	4.8
Vanilla essence	5 ml

Prices of items sold in a supermarket		
Items	Price	Quantity
All purpose flour	\$2.20 per packet	1 kg per packet
Butter	\$4.40 per slab	250 g per slab
Brown sugar	\$5.50 per packet	1 kg per packet
Semi-sweet chocolate chips	\$6.90 per packet	340 g per packet
Vanilla essence	\$2.00 per bottle	33 ml per bottle
Salt	\$0.50 per packet	500 g per packet
Eggs	\$3.75	12 eggs per box
	\$5.50	15 eggs per box
	\$7.85	30 eggs per box
Food paper bags	\$1	20 pieces per pack
	\$2.85	60 pieces per pack

- (c) The class targets to make a profit of at least 50%.
They have to ensure minimum wastage of the items they purchase.
Suggest a sensible selling price to be charged for each bag of cookies.
Justify the decision you make and show your calculations clearly.

.....

.....

.....[7]

END OF PAPER

St. Anthony's Canossian Secondary School
Marking Scheme for 2023 Prelim 4E Mathematics Paper 1

Qn	Worked Solution	Total	Remarks
1a	14.777	1	
1b	15	1	
2	$3(5a-2)-(8-4a)$ $=15a-6-8+4a$ $=19a-14$	2	Remove ()
3	$3-\frac{x}{4}=\frac{2(x-2)}{3}$ $\times 12:$ $36-3x=8(x-2)$ $36-3x=8x-16$ $-11x+52=0$ $11x-52=0$ $A=11, B=-52$	2	Get rid of denominator
4a	Percentage increase = $\frac{20-10}{10} \times 100$ $=100\%$	1	
4b	The scale used on the vertical axis is very small while the scale use on the horizontal axis is very big. Therefore, the increase in the number of patients looks much lesser than it should be, for example, from 2018 to 2019, there was a sharp increase of 100% but the graph shown a much gradual increase.	1	Accept if able to identify inappropriate scale for either vertical or horizontal axis and state the misleading representation.
5a	$x^2-6x-16$ $=(x-3)^2-(3)^2-16$ $=(x-3)^2-25$	1	
5b	$(x-3)^2 \geq 0$ for all real values of x $(x-3)^2-25 \geq -25$ Hence, $x^2-6x-16$ is always -25 or more (or minimum is -25) and hence cannot be -30 .	1	Needs to <u>show algebraically</u> why the minimum is -25 Not accepted if just state minimum point is $(3, -25)$ Accept if set completed square expression to -30 and showed x is not defined and conclude expression cannot be -30 . If just state, x is undefined without conclusion, no A1.

Qn	Worked Solution	Total	Remarks
6a	$336 = 2^4 \times 3 \times 7$	1	
6bi	LCM of 336 and 1764 = $2^4 \times 3^2 \times 7^2$	1	
6bii	$n = 2^2 \times 3 \times 7 = 84$	1	
7	See attached solution.		Minus 1 mark if never label a(i) and a(ii)
8	Total number of children = 1.82×10 = 182 Let the number of families with 2 children be n $25 + 2n + 3(65 - n) = 182$ $220 + 2n - 3n = 182$ $-n = -38$ $n = 38$	3	Find total Form equation
9	On x-axis, $y = 0$: $3x = 24$ $x = 8$ $P = (8, 0)$ On y-axis, $x = 0$: $5y = 24$ $y = 4.8$ $Q = (0, 4.8)$ Length of $PQ = \sqrt{(8-0)^2 + (0-4.8)^2}$ = 9.33 units	3	Either correct P or Q coordinates or showing either the x or y intercept value Length formula based on their coordinates.
10a	$\angle TPR = 180^\circ - 139^\circ$ (\angle s in opp segments) = 41°	1	
10b	$\angle PRQ = 35^\circ$ (\angle s in same segment) $\angle PRQ = 35^\circ$ and $\angle TPR = 41^\circ$. $\angle PRQ$ and $\angle TPR$ are alternate angles that are not equal , hence TP and RQ are not parallel.	2	Must show why $\angle PRQ \neq \angle TPR$ and quote property. Not accepted if $\angle PRQ$ and $\angle TPR$ are not alternate angles.
11	$\frac{8x - 12y}{2x^2 - xy - 3y^2}$ $= \frac{4(2x - 3y)}{(2x - 3y)(x + y)}$ $= \frac{4}{x + y}$	3	Factorise numerator and denominator.

Qn	Worked Solution	Total	Remarks
12a	Triangle XYP and Triangle QZY	1	Must be correct order of points.
12b	$XY = QZ$ (Given) $PY = YZ$ (Given) Let $\angle XYP = a^\circ$ $\angle XYZ = 180^\circ - a^\circ$ (adj. \angle s on a st. line) $\angle XYZ = \angle XZY$ (base \angle s, isosceles Δ) $\therefore \angle YZQ = 180^\circ - (180^\circ - a^\circ)$ (adj. \angle s on a st. line) $= a^\circ$ $\therefore \angle XYP = \angle YZQ = a^\circ$ Triangle XYP and Triangle QZY are congruent (SAS Test)	2	Identify 2 pairs of equal sides with reasons. For proving, if the order of alphabet for sides and angles not in correct order, can accept. Reasons must be seen for each step. Prove one pair of equal angles and conclude with correct test
13a	$\frac{3 \times 10^8}{10^6} = 300$ million	1	
13bi	$500 \times 10^{-9} = 5 \times 10^{-7}$ m	1	Accept 5.0 or 5.00 seen
13bii	$f = \frac{3 \times 10^8}{5 \times 10^{-7}}$ or $f = \frac{3 \times 10^8}{500 \times 10^{-9}}$ $f = 6 \times 10^{14}$	1	
14	One interior angle of pentagon = $\frac{(5-2) \times 180^\circ}{5}$ $= 108^\circ$ One exterior angle of hexagon = $\frac{360^\circ}{6}$ $= 60^\circ$ $\angle JEI = 108^\circ - 60^\circ$ $= 48^\circ$	3	Minus 1 mark if no statement at all for workings. Never write degree symbol for in between steps but wrote at final answer, let go.
OR	One interior angle of pentagon = $\frac{(5-2) \times 180^\circ}{5}$ $= 108^\circ$ One interior angle of hexagon $= \frac{(6-2) \times 180^\circ}{6} = 120^\circ$ $\angle FEJ = 180^\circ - 120^\circ$ (adj. \angle s on a st line) $= 60^\circ$ $\angle JEI = 108^\circ - 60^\circ$ $= 48^\circ$	3	

Qn	Worked Solution	Total	Remarks
15a	$\frac{16}{T} = 2$ $T = 8 \text{ seconds}$	1	
15b	Distance travelled = $\frac{1}{2}(40+50) \times 16$ $= 720 \text{ m}$ Average speed = $720 \div 50$ $= 14.4 \text{ m/s}$	2	
16	$8a^3 + 8a^2b - 2ab^2 - 2b^3$ $= 8a^2(a+b) - 2b^2(a+b)$ $= (a+b)(8a^2 - 2b^2)$ $= 2(a+b)(4a^2 - b^2)$ $= 2(a+b)(2a+b)(2a-b)$	3	
17	Fraction of sum Jess gets = $\frac{2}{5} \times \frac{3}{5} = \frac{6}{25}$ Fraction of sum Lin gets = $\frac{3}{5} \times \frac{3}{5} = \frac{9}{25}$ Ratio of sum received for Jess : Lin : Kim $= 6 : 9 : 10$ 4 units --- \$640 1 unit --- $\$640 \div 4 = \160 \therefore Lin gets 9×160 $= \$1440$	4	Calculate fraction either Jess or Lin gets. Ratio of sum Calculate 1 unit based on their ratio
OR	Fraction of sum Jess gets = $\frac{2}{5} \times \frac{3}{5} = \frac{6}{25}$		
	Difference between Kim and Jess $= \frac{2}{5} - \frac{6}{25}$ $= \frac{4}{25}$		

Qn	Worked Solution	Total	Remarks
	$\frac{4}{25} \text{-----} \640 $\frac{1}{25} \text{-----} \$ \frac{640}{4}$ $\frac{9}{25} \text{-----} \$ \frac{640}{4} \times 9$ $= \$1440$	4	
18ai	$\sqrt[4]{81a^{\frac{5}{3}}}$ $= 3 \left(a^{\frac{5}{3}} \right)^{\frac{1}{4}}$ $= 3a^{\frac{5}{12}}$	1	
18aii	$18n^{-9} \div (3n^{-2})^2$ $= 18n^{-9} \div 9n^{-4}$ $= 2n^{-9+4}$ $= 2n^{-5}$ $= \frac{2}{n^5}$	2	For $9n^{-4}$
18b	$2^7 \times 16^k = 2^k$ $2^7 \times 2^{4k} = 2^k$ $7 + 4k = k$ $k = -\frac{7}{3}$ <p>Accept $k = -2\frac{1}{3}$</p>	2	Change to base 2
19ai	There are students whose heights are not greater than 170 cm (or 170 cm or less) and who enjoy playing basketball.	1	Not accept below 170 cm, must be 170 cm or below
19aii	$B \subset S$	1	
19bi	$P = \{ 42, 45, 48, 51, 54 \}$ $n(P) = 5$	1	
19bii	$Q = \{ 42, 48, 54 \}$ $P \cap Q = \{ 42, 48, 54 \}$	1	A0 if no { }

Qn	Worked Solution	Total	Remarks
19biii		1	B0 if no P and Q seen beside circle. B0 if the 2 circles drawn as
20a	$W = \begin{pmatrix} 0.625 \\ 0.5 \end{pmatrix}$	1	
20b	$T = \begin{pmatrix} 64 & 70 \\ 56 & 48 \\ x & 44 \end{pmatrix} \begin{pmatrix} 0.625 \\ 0.5 \end{pmatrix}$ $= \begin{pmatrix} 75 \\ 59 \\ 0.625x + 22 \end{pmatrix}$	1	A0 if working showed W as a 1x2 row matrix in working even if correct answer.
20ci	$0.625x + 22 = 42$ $0.625x = 20$ $x = 32$	1	
20cii	$D = \frac{1}{3} \begin{pmatrix} 1 & 1 & 1 \\ 75 \\ 59 \\ 42 \end{pmatrix}$ $= \frac{1}{3} (176)$ $= (58.7)$	1	A0 if no () for answer. Accept $\left(\frac{176}{3}\right)$ or $\left(58\frac{2}{3}\right)$
20ciii	Matrix D gives the average (mean) mark of the 3 girls which is 58.7 .	1	3 girls must be seen. Value must be quoted as a decimal else B0.
21	$\angle PLM = 90^\circ - 30^\circ$ $= 60^\circ$	5	Finding angle in 1 st right-angled triangle derived from angle of depression. Correct value only.

Qn	Worked Solution	Total	Remarks
	$\sin 60^\circ = \frac{15}{PL}$ $PL = \frac{15}{\sin 60^\circ}$ $PL = 17.321$ $\angle MPL = 180^\circ - 90^\circ - 60^\circ (\angle \text{ sum of } \Delta)$ $= 30^\circ$ $\angle MPX = 90^\circ - 30^\circ$ $= 60^\circ$ $\sin 60^\circ = \frac{MX}{15}$ $MX = 15 \sin 60^\circ$ $MX = 12.990$ <p>Difference in vertical height = $17.321 - 12.990$ = 4.33 m</p>		<p>Finding QL based on their angle.</p> <p>Finding angle in 2nd right angled triangle. Correct value only.</p> <p>Finding MX based on their angle.</p> <p>If used shorter method, the last step of answer is 2 marks.</p>
OR	$\angle LME = 30^\circ (\text{alt. } \angle \text{s})$ $\angle EMP = 90^\circ - 30^\circ$ $= 60^\circ$ $\cos 60^\circ = \frac{EM}{15}$ $EM = 15 \cos 60^\circ$ $EM = 7.5 \text{ m}$ $\tan 30^\circ = \frac{EL}{7.5}$ $EL = 7.5 \tan 30^\circ$ $EL = 4.33 \text{ m}$	5	<p>Correct value only</p> <p>Correct value only</p> <p>Finding EM based on their angle.</p> <p>Based on their EM</p>
22a	32 mins	1	
22b	$\frac{45 + 49}{2} = 47 \text{ mins}$	1	Working needed.
22ci	40.2 mins	1	
22cii	9.06 mins	1	

Qn	Worked Solution	Total	Remarks
22d	The times taken to clear the custom on a weekday were more consistent than that on a weekend as the standard deviation for weekday (9.06 minutes) is smaller than that for weekend (11.5 minutes).	1	Need to quote values of SD. Accept if used 1 st group and 2 nd group. Accept if write only the "times" without stating taken to clear the custom.
23a	Let the slant height of the small cone be l_s cm. $\frac{l_s}{l_s + x} = \frac{22}{30}$ $\frac{l_s}{l_s + x} = \frac{11}{15}$ $15l_s = 11l_s + 11x$ $4l_s = 11x$ $l_s = \frac{11}{4}x$	2	
23b	Let the volume of the small cone be V_s cm ³ $\frac{V_s}{600\pi} = \left(\frac{11}{15}\right)^3$ $V_s = \left(\frac{11}{15}\right)^3 \times 600\pi$ $= 743.37 \text{ cm}^3$ Volume required = $600\pi - 743.37$ $= 1141.59$ $= 1140 \text{ cm}^3 \text{ (3sf)}$	4	Similarity concept for volume. Correct value of volume of small cone. Subtract volumes to get value based on their volume of small cone.
OR	Let radius of big cone be R cm $\frac{1}{3}\pi R^2 (30) = 600\pi$ $R = \sqrt{\frac{600 \times 3}{30}}$ $R = \sqrt{60} \text{ or } 7.74597$ Let radius of big cone be r cm $\frac{r}{\sqrt{60}} = \frac{11}{15}$	4	Similarity concept based on their R .

Qn	Worked Solution	Total	Remarks								
	$r = \frac{11}{15} \times \sqrt{60}$ $= 5.6804$ <p>Volume of small cone = $\frac{1}{3}\pi(5.6804)^2(22)$</p> $= 743.38 \text{ cm}^3$ <p>Volume required = $600\pi - 743.38$</p> $= 1141.58$ $= 1140 \text{ cm}^3 \text{ (3sf)}$		<p>Correct value of volume of small cone.</p> <p>Subtract volumes to get value based on their volume of small cone.</p>								
24a	<table border="1"> <thead> <tr> <th>Row</th> <th>Mathematical sentence</th> <th>Sum</th> <th>Number of odd integers added</th> </tr> </thead> <tbody> <tr> <td>6</td> <td>1+3+5+7+9+11+13</td> <td>49</td> <td>7</td> </tr> </tbody> </table>	Row	Mathematical sentence	Sum	Number of odd integers added	6	1+3+5+7+9+11+13	49	7	1	
Row	Mathematical sentence	Sum	Number of odd integers added								
6	1+3+5+7+9+11+13	49	7								
24b	The numbers in the column for sum are all perfect squares but 200 is not a perfect square and hence it cannot be a value for a sum.	1									
24ci	$k = 2n + 1$	2	Accept $S = n^2 + 2n + 1$								
24cii	$S = (n+1)^2$										
24d	$(n+1)^2 = 1024$ $n = \pm\sqrt{1024} - 1$ $n = 31 \text{ or } n = -32(\text{reject})$ <p>Number of odd integers = 32</p>	2	<p>Accept if found answer by just taking $\sqrt{1024} = 32$</p> <p>Finding n.</p> <p>Accept if never show -32 or never reject</p>								
25a	<p>Volume of tank = $20 \times 20 \times 12 = 4800 \text{ cm}^3$</p> <p>Volume of water = $\frac{1}{2} \times 4800 = 2400 \text{ cm}^3$</p>	2									
OR	<p>Volume of water = $\left(\frac{1}{2} \times 20 \times 12\right) \times 20$</p> $= 2400 \text{ cm}^3$	2	Correct triangular cross section								

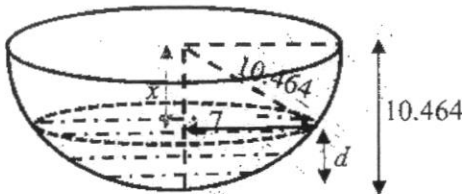
Qn	Worked Solution	Total	Remarks
25bi	Let radius of hemispherical bowl be r cm. $\frac{2}{3}\pi r^3 = 2400$	2	Volume of hemisphere based on their (a)
	$r = \sqrt[3]{\frac{2400 \times 3}{2\pi}}$ $r = 10.464$ $r = 10.5$		
25bii	 <p>$x^2 + 7^2 = (10.464)^2$</p> <p>$x = \sqrt{(10.464)^2 - 7^2}$</p> <p>$= 7.7779$</p> <p>$d = 10.464 - 7.7779$</p> <p>$= 2.69$</p>	2	Pythagoras Theorem based on their radius.

7 The diagram shows a plot of land $ABCD$ with a house in one corner.

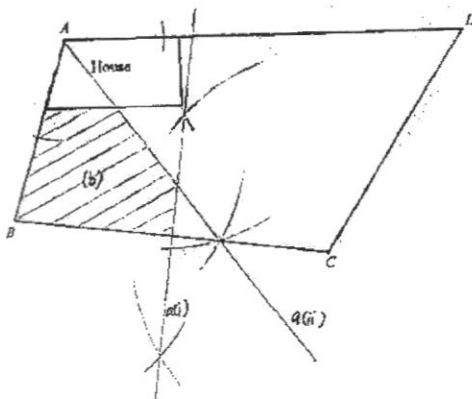

St. Anthony's Canossian Secondary School

Marking Scheme for 2023 Prelim 4E Mathematics Paper 2

Qn	Worked Solution	Total	Remarks
1ai	$m = \sqrt[3]{\frac{5v - 4c^2}{v - 6}}$ $m = \sqrt[3]{\frac{5(3) - 4\left(\frac{1}{2}\right)^2}{3 - 6}}$ $m = -1.6711$ $m = -1.67 \text{ (3 sf)}$	1	
1aii	$m = \sqrt[3]{\frac{5v - 4c^2}{v - 6}}$ $m^3 = \frac{5v - 4c^2}{v - 6}$ $m^3v - 6m^3 = 5v - 4c^2$ $m^3v - 5v = 6m^3 - 4c^2$ $v(m^3 - 5) = 6m^3 - 4c^2$ $v = \frac{6m^3 - 4c^2}{m^3 - 5}$	3	<p>Cube both sides and get rid of denominator.</p> <p>Factorise</p> <p>Accept $v = \frac{4c^2 - 6m^3}{5 - m^3}$</p>
1b	$2x + 5y = 25 \text{ --- (1)}$ $3x - 2y = 9 \text{ --- (2)}$ $(1) \times 3: 6x + 15y = 75 \text{ --- (3)}$ $(2) \times 2: 6x - 4y = 18 \text{ --- (4)}$ $(3) - (4): 19y = 57$ $y = 3$ <p>Put $y = 3$ in (1):</p> $2x + 5(3) = 25$ $2x = 10$ $x = 5$	3	Attempt elimination or substitution method.

Qn	Worked Solution	Total	Remarks
1c	$\frac{2}{(3x-2)^2} - \frac{1}{2-3x}$ $= \frac{2}{(3x-2)^2} + \frac{1}{3x-2}$ $= \frac{2+3x-2}{(3x-2)^2}$ $= \frac{3x}{(3x-2)^2}$	2	
1d	$2x-5 = \frac{15}{x-2}$ $(2x-5)(x-2) = 15$ $2x^2 - 4x - 5x + 10 - 15 = 0$ $2x^2 - 9x - 5 = 0$ $(2x+1)(x-5) = 0$ $x = -\frac{1}{2} \text{ or } x = 5$	3	Expand to get quadratic equation Factorise 2 correct answers
2ai	$\text{Deposit} = \frac{30}{100} \times 172000$ $= \$51\,600$ $\text{Total amount paid} = 51\,600 + (36 \times 3825)$ $= \$189\,300$	2	Find deposit
2aii	$\text{Extra cost} = \frac{189300 - 172000}{172000} \times 100$ $= 10.1\%$	2	Using their total amount
2b	$\text{Balance} = \frac{70}{100} \times 172000$ $= \$120\,400$ $\text{Total amount} = 120400 \left(1 + \frac{2}{100}\right)^{10}$ $= \$146\,766.928$ $\text{Total interest} = 146766.928 - 120400$ $= \$26\,366.928$ $= \$26\,366.93$	4	Finding balance Total amount based on their balance, r and n must be correct Their total amount minus their balance
2c	$\text{RM}3.32 \text{ --- S\$}1$ $\text{RM } 328\,416 \text{ --- S\$} \frac{328416}{3.32}$ $= \text{S\$}98\,920.482$ $\text{Difference} = \text{S\$}(172\,000 - 98\,920.482)$ $= \text{S\$}73\,079.52$	2	

Qn	Worked Solution	Total	Remarks						
3a	$p = \frac{4^2}{5} + \frac{12}{4} - 4$ $p = 2.2$	1							
3b	Correct points Smoothness	3							
3c	$\frac{x^2}{5} + \frac{12}{x} - 5 = 0$ $+1: \frac{x^2}{5} + \frac{12}{x} - 4 = 1$ <p>The line <u>$y = 1$ does not intersect the curve</u> $y = \frac{x^2}{5} + \frac{12}{x} - 4$, hence there is no solution for $\frac{x^2}{5} + \frac{12}{x} - 5 = 0$.</p>	1							
3di	$2y + x = 10$ $y = -\frac{1}{2}x + 5$ <table border="1" style="margin-left: auto; margin-right: auto;"> <tr> <td>x</td> <td>1</td> <td>7</td> </tr> <tr> <td>y</td> <td>4.5</td> <td>1.5</td> </tr> </table> <p>Line drawn passing through endpoints at $x=1$ and $x=7$</p>	x	1	7	y	4.5	1.5	1	
x	1	7							
y	4.5	1.5							
3dii	$x = 1.6$ (accept 1.55, 1.65) or $x = 4.5$ (accept 4.45, 4.55)	2							
3diii	Put $y = -\frac{1}{2}x + 5$ in $y = \frac{x^2}{5} + \frac{12}{x} - 4$: $-\frac{1}{2}x + 5 = \frac{x^2}{5} + \frac{12}{x} - 4$ $\times 10x$: $-5x^2 + 50x = 2x^3 + 120 - 40x$ $2x^3 + 5x^2 - 90x + 120 = 0$	2	Substitute one equation into the other and attempt to remove denominator.						
4a	$\angle AYC = 90^\circ$ (\angle in a semicircle) $\angle CYB = 90^\circ$ (\angle in a semicircle) $\therefore \angle AYC = \angle CYB$ let $\angle CA Y = x^\circ$ $\angle AC Y = 180^\circ - 90^\circ - x^\circ$ (\angle sum of Δ) $= 90^\circ - x^\circ$ $\angle BC A = 90^\circ$ (radius \perp tangent) $\angle BC Y = 90^\circ - (90^\circ - x^\circ)$ $= x^\circ$ $\therefore \angle CA Y = \angle BC Y = x^\circ$ Triangle $AC Y$ is similar to triangle $BC Y$ (AAA test)	2	Show 1st pair of equal angles Show 2nd pair of equal angles						

Qn	Worked Solution	Total	Remarks
4bi	$\sin 0.663 = \frac{CY}{10}$ $CY = 10 \sin 0.663$ $= 6.1548$ <p>Area of triangle CBY</p> $= \frac{1}{2}(6.1548)(4.81)$ $= 14.802$ $= 14.8 \text{ cm}^2$	3	Find CY Area of triangle using their CY
OR	<p>From (a), $\angle CAY = \angle BCY \therefore \angle BCY = 0.663$ radians</p> $\tan 0.663 = \frac{4.81}{CY}$ $CY = \frac{4.81}{\tan 0.663}$ $= 6.1594$ <p>Area of triangle $CBY = \frac{1}{2}(6.1594)(4.81)$</p> $= 14.813$ $= 14.8 \text{ cm}^2$	3	Find CY Area of triangle using their BY
4bii	<p>Let centre of bigger circle be O</p> $\angle COY = 2 \times 0.663$ $= 1.326 \text{ radians}$ <p>Area of segment CY</p> $= \frac{1}{2}(5)^2(1.326) - \frac{1}{2}(5)^2 \sin 1.326$ $= 4.4477 \text{ cm}^2$ <p>Area of shaded part</p> $= 14.802 - 4.4477$ $= 10.3543$ $= 10.4 \text{ cm}^2$	4	Finding $\angle COY$ Areas of sector minus area of triangle based on their $\angle COY$
5ai	$\overrightarrow{OQ} - \overrightarrow{OP} = \begin{pmatrix} -9 \\ 4 \end{pmatrix}$ $\overrightarrow{OQ} = \begin{pmatrix} -9 \\ 4 \end{pmatrix} + \overrightarrow{OP}$ $\overrightarrow{OQ} = \begin{pmatrix} -9 \\ 4 \end{pmatrix} + \begin{pmatrix} 4 \\ -3 \end{pmatrix}$ $= \begin{pmatrix} -5 \\ 1 \end{pmatrix}$ $ \overrightarrow{OQ} = \sqrt{(-5)^2 + 1^2}$ $= 5.10 \text{ units}$	2	Find \overrightarrow{OQ}

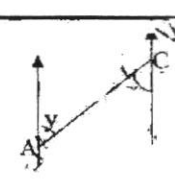
Qn	Worked Solution	Total	Remarks
5aii	Gradient of $PQ = -\frac{4}{9}$ Equation of $PQ : y = -\frac{4}{9}x + c$ Subst. $(4, -3), -3 = -\frac{4}{9}(4) + c$ $c = -\frac{11}{9}$ $y = -\frac{4}{9}x - \frac{11}{9}$ or $9y = -4x - 11$	2	Finding gradient
5bi	$\overline{CB} = \overline{CA} + \overline{AB}$ $= -q + p$	1	
5bii	$\overline{XY} = \overline{XB} + \overline{BY}$ $= \frac{3}{5}\overline{AB} + \frac{1}{3}\overline{BC}$ $= \frac{3}{5}p + \frac{1}{3}(q - p)$ $= \frac{3}{5}p + \frac{1}{3}q - \frac{1}{3}p$ $= \frac{4}{15}p + \frac{1}{3}q$	3	For $\overline{XB}, \overline{BY}$ in terms of p and q
5biii	$\frac{\text{Area of } \triangle XBC}{\text{Area of } \triangle ABC} = \frac{3}{5}$ $\text{Area of } \triangle XBC = \frac{3}{5} \times 30$ $= 18 \text{ cm}^2$	1	
5biv	$\overline{XY} = 2\left(\frac{2}{15}p + \frac{1}{6}q\right) = 2\overline{XM}$ Since $\overline{XY} = 2\overline{XM}$ and X is a common point, X, Y, M are collinear points.	2	Show $\overline{XY} = 2\overline{XM}$ Conclude collinear with evidence of a common point in the pair of parallel vectors.
6a	$x = 220^\circ - 180^\circ$ $= 40^\circ$ $y = 40^\circ$ (alt. \angle s, parallel lines) Bearing of C from $A = 040^\circ$ 	1	
6b	$AB^2 = 70^2 + 50^2 - 2(70)(50)\cos 62^\circ$ $AB = \sqrt{4113.70}$ $AB = 64.138$ $AB = 64.1 \text{ m}$	3	Show value in square root

Qn	Worked Solution	Total	Remarks
6c	$\frac{\sin \angle BAD}{50} = \frac{\sin 62^\circ}{64.138}$ $\sin \angle BAD = \frac{\sin 62^\circ}{64.138} \times 50$ $\sin \angle BAD = 0.68832$ $\angle BAD = \sin^{-1}(0.68832)$ $= 43.497^\circ$ Bearing of B from A $= 40^\circ + 43.497^\circ$ $= 083.5^\circ$	3	Sine rule based on their AB .
7a	Area of trapezium $PQRD$ $= \frac{1}{2}(x)[8+(8-x)]$ $= \frac{1}{2}(x)(16-x)$ $= 8x - \frac{1}{2}x^2$ Area of triangle QCR $= \frac{1}{2}(8)(10-x)$ $= 40 - 4x$ $8x - \frac{1}{2}x^2 + 40 - 4x = 47$ $-\frac{1}{2}x^2 + 4x - 7 = 0$ $\times(-2): x^2 - 8x + 14 = 0$	5	Correct area of trapezium Simplified, correct answer only Correct area of triangle Equate their sum of the 2 areas to 47
7b	$x = \frac{-(-8) \pm \sqrt{(-8)^2 - 4(1)(14)}}{2(1)}$ $x = \frac{8 \pm \sqrt{8}}{2}$ $x = 2.5858 \quad \text{or} \quad x = 5.4142$ $x = 2.59 \quad \text{or} \quad x = 5.41$	4	M1: Quadratic formula M1: For their $b^2 - 4ac$
7c	Use $x = 5.4142$ Smallest possible area of triangle FQR $= \frac{1}{2}(8)(10 - 5.4142)$ $= 18.3 \text{ cm}^2$	2	Using their larger x to find smallest possible FQ

Qn	Worked Solution	Total	Remarks
8ai(a)	Median = 84 km/h	1	
8ai(b)	Interquartile range = 88 - 78 = 10 km/h	2	Working needed. No working, minus 1 mark.
8a(ii)	Required percentage = $\frac{200 - 164}{200} \times 100$ = 18%	2	Correct number of vehicles with speed > 90 km/h.
8a(iii)	$P(\text{speed} > y) = \frac{1}{5}$ $= \frac{40}{200}$ $y = 89.5 \text{ km/h}$ (accept 89 km/h)	1	
8a(iv)	Number of vehicles with speed between 80 km/h to 100km/h = 188 - 60 = 128 Required probability = $\left(\frac{128}{200}\right)\left(\frac{72}{199}\right) + \left(\frac{72}{200}\right)\left(\frac{128}{199}\right)$ = 0.463	2	Accept $\frac{2304}{4975}$
8bi	Lower quartile = 64 km/h Required probability = $\frac{1}{4}$	1	Accept 0.25
8bii	No, I disagree. On average, the vehicles travelling on the expressway in the afternoon are faster as their median speed (92 km/h) is greater than the median speed (89.5 km/h) of vehicles in the morning.	1	Must quote values of median.
9a	Conversion factor = $\frac{250}{48}$ = 5.2083 = 6	1	
9b	Amount of vanilla essence needed = 6×10 = 60 ml Cost of vanilla essence = $2 \times \$2$ = \$4	2	
9c	Total amount needed for each ingredients: Butter --- $230 \times 6 = 1380 \text{ g}$ Brown sugar --- $(160 \times 2) \times 6 = 1920 \text{ g}$ Flour --- $(140 \times 3) \times 6 = 2520 \text{ g}$ Chocolate chips-- $(190 \times 1.5) \times 6 = 1710 \text{ g}$ Eggs --- $2 \times 6 = 12 \text{ eggs}$ Salt --- $3.5 \times 6 = 21 \text{ g}$	7	Attempt to calculate amount of at least 3 ingredients

Qn	Worked Solution	Total	Remarks
	Cost of each ingredient: Butter --- $\frac{1380}{250} = 5.52$ slabs Cost of butter = $6 \times 4.40 = \$26.40$ Brown sugar-- $\frac{1920}{1000} = 1.92$ packets Cost of brown sugar = $2 \times 5.50 = \$11$ Flour --- $\frac{2520}{1000} = 2.25$ packets Cost of flour = $3 \times 2.20 = \$6.60$ Chocolate chips--- $\frac{1710}{340} = 5.029$ packets Cost of chocolate chips = $6 \times 6.90 = \$41.40$		Calculate cost of at least 2 ingredients based on their total amount needed for each item.
	Cost of 12 eggs = \$3.75 Cost of salt = \$0.50		Calculate cost of eggs and salt.
	Total cost of ingredients and paper bags $= 26.40 + 11 + 6.60 + 41.40 + 3.75 + 0.50 + 4 + 2.85$ $= \$96.50$		Correct total cost only
	$100\% \text{-----} \$96.50$ $150\% \text{-----} \$ \frac{150 \times 96.50}{100}$ $= \$ 144.75$		Attempt to calculate total sales value to enjoy 50% profit.
	Selling price of each bag of cookies $= \frac{144.75}{50}$ $= \$2.895$		Correct selling price per packet only
	Any selling price $\geq \$2.90$ will enable at least 50% profit. Hence, the selling price can be \$3, whole number value is easier to collect money.		Any sensible amount $\geq \$2.90$ with correct previous A1 step.

