

Visit

FREETESTPAPER.com

for more papers



Website: [freetestpaper.com](http://www.freetestpaper.com)



[Facebook.com/freetestpaper](https://www.facebook.com/freetestpaper)



[Twitter.com/freetestpaper](https://www.twitter.com/freetestpaper)



BENDEMEER SECONDARY SCHOOL
2024 PRELIMINARY EXAMINATION
SECONDARY 4 EXPRESS / 5 NORMAL (ACADEMIC)

CANDIDATE
NAME

CLASS

INDEX
NUMBER

MATHEMATICS

Paper 1

4052/01

20 Aug 2024

2 hours 15 minutes

Candidates answer on the Question Paper.
No additional materials are required.

READ THESE INSTRUCTIONS FIRST

Write your name, class and register number on all the work you hand in.
Write in dark blue or black pen.
You may use an HB pencil for any diagrams or graphs.
Do not use staples, paper clips, glue or correction fluid/tape.
DO NOT WRITE ON ANY BARCODES.

Answer **all** questions.
The number of marks is given in brackets [] at the end of each question or part question.

If working is needed for any question, it must be shown with the answer.
Omission of essential working will result in loss of marks.
The total of the marks for this paper is 90.

The use of an approved scientific calculator is expected, where appropriate.
If the degree of accuracy is not specified in the question, and if the answer is not exact, give the answer to three significant figures. Give answers in degrees to one decimal place.
For π , use either your calculator value or 3.142.

FOR EXAMINER'S USE	
	90

MATHEMATICAL FORMULAE*Compound Interest*

$$\text{Total amount} = P \left(1 + \frac{r}{100} \right)^n$$

Mensuration

$$\text{Curved surface area of cone} = \pi r l$$

$$\text{Surface area of a sphere} = 4 \pi r^2$$

$$\text{Volume of a cone} = \frac{1}{3} \pi r^2 h$$

$$\text{Volume of sphere} = \frac{4}{3} \pi r^3$$

$$\text{Area of triangle ABC} = \frac{1}{2} ab \sin C$$

$$\text{Arc length} = r\theta, \text{ where } \theta \text{ is in radians}$$

$$\text{Sector area} = \frac{1}{2} r^2 \theta, \text{ where } \theta \text{ is in radians}$$

Trigonometry

$$\frac{a}{\sin A} = \frac{b}{\sin B} = \frac{c}{\sin C}$$

$$a^2 = b^2 + c^2 - 2bc \cos A$$

Statistics

$$\text{Mean} = \frac{\sum fx}{\sum f}$$

$$\text{Standard Deviation} = \sqrt{\frac{\sum fx^2}{\sum f} - \left(\frac{\sum fx}{\sum f} \right)^2}$$

Answer **all** the questions.

1 Factorise each of the following completely.

(a) $4a^2 - b^2$

Answer [1]

(b) $5x - 1 + 10x^2y - 2xy$

Answer [2]

2 (a) Simplify $(2x^3y)^3$.

Answer [1]

(b) Use the laws of indices to solve the following equation for x . Show your working clearly.

$$2^2 \times 5^3 + \frac{1}{125^x} = 5^4.$$

Answer $x =$ [2]

- 3 (a) Express 1176 as a product of its prime factors.

Answer [1]

- (b) The number $1176k$ is a perfect cube.
Find the smallest positive integer value of k .

Answer $k =$ [1]

- (c) The highest common factor of two distinct integers, n and 1176, is 28.
Given that $500 < n < 1000$, find the smallest possible value of n .

Answer $n =$ [1]

- 4 The volume of a right pyramid is $4.8 \times 10^{-8} \text{ m}^3$ and its length of the square base is $1.5 \times 10^{-3} \text{ m}$. Giving your answer in standard form, find its height.

Answer m [2]

- 5 Benjamin invested \$8000 at a rate of 3.3% per annum compounded monthly. What is the value of his investment at the end of 6 months?

Answer \$ [2]

- 6 (a) In the Venn diagram below, shade the region $P \cup Q'$.

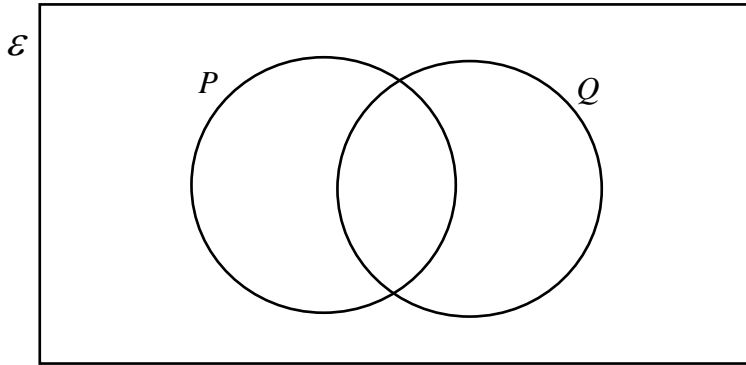

[1]

- (b) A universal set ε and its subset A and B are given by
 $\varepsilon = \{x: x \text{ is an integer and } 0 < x < 12\}$,
 $A = \{x: x \text{ is a factor of } 24\}$,
 $B = \{x: 2x - 7 \geq 5\}$.

- (i) Write all the elements of ε in the Venn diagram below.

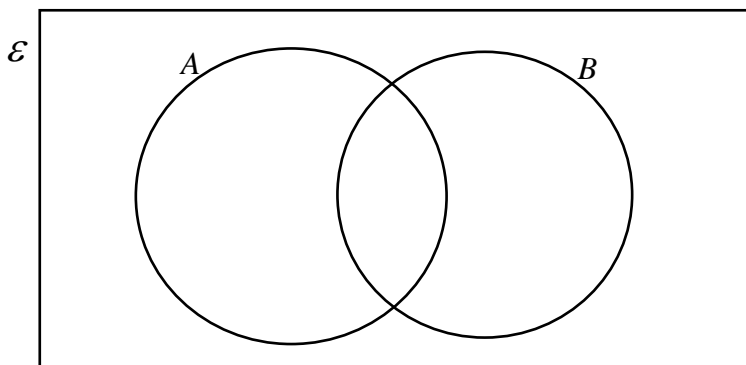

[2]

- (ii) Another number is included in the universal set ε .
 This number is in the region $A \cap B$.
 Write down a possible value of this number.

Answer [1]

- 7 The expression $2x^2 + 8x + 9$ is equivalent to $2(x + a)^2 + b$.
- (a) Find the value of a and the value of b .

Answer $a = \dots\dots\dots$ [1]

$b = \dots\dots\dots$ [1]

- (b) Sketch the curve $y = 2x^2 + 8x + 9$ on the given axes below, clearly showing the y-intercept and the turning point.

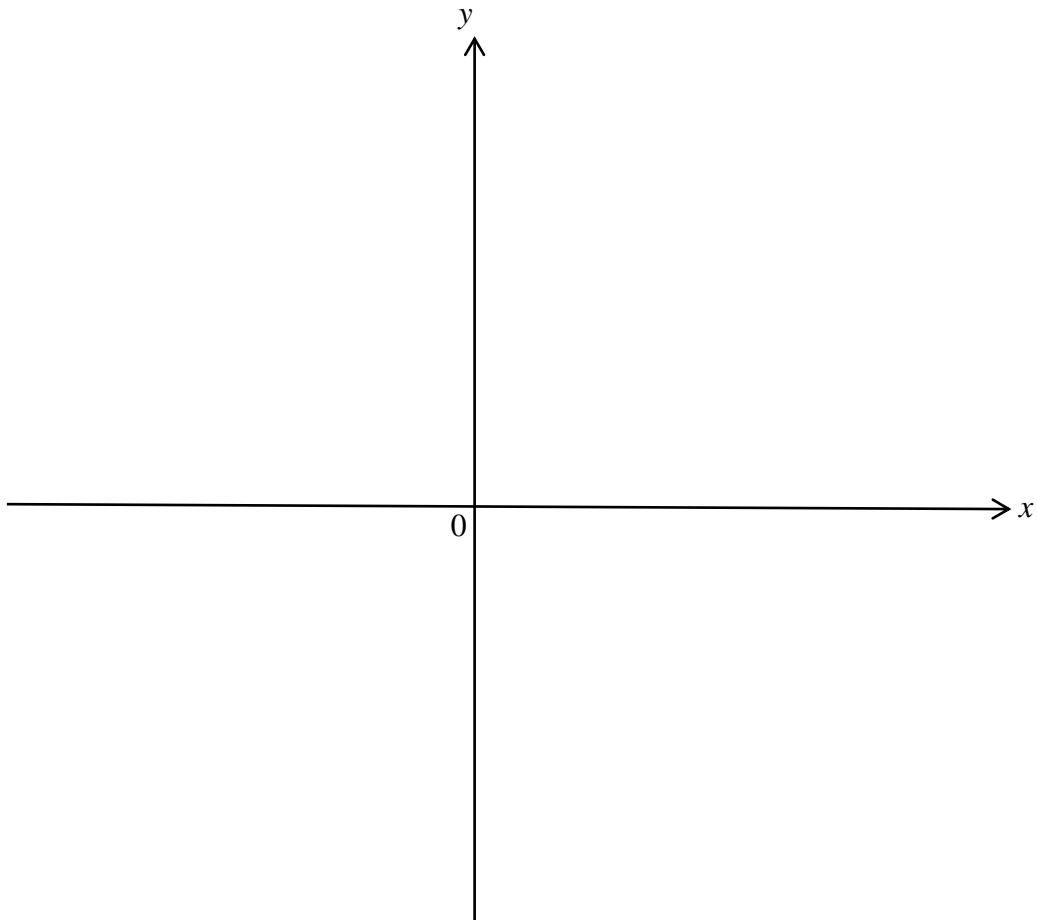

[2]

- 8 Given that the formula of y is inversely proportional to the square of $(x + 2)$ and the value of $y = \frac{1}{3}$ when $x = 7$.

(a) Express y in terms of x .

Answer $y = \dots\dots\dots$ [2]

(b) Hence, or otherwise, make x the subject of the formula.

Answer $x = \dots\dots\dots$ [2]

- 9 Explain why $(2n + 3)^2 - (4n + 3)(n - 6)$ is a multiple of 3 for all integer values of n .

Answer

.....

[2]

- 10 Simplify $\frac{2x+3}{x^2+3x+2} - \frac{5}{x+1}$ as a single fraction.

Answer

[3]

- 11 (a) Solve the inequality $x - 7 \leq \frac{3x-5}{2} < 8$.

Represent your solution on the number line below.

Answer

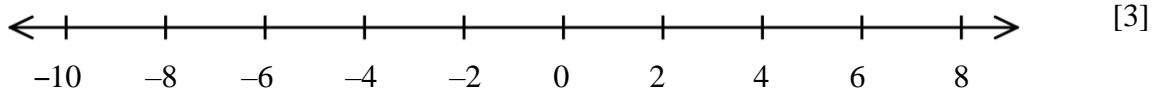

- (b) Hence, write down the largest prime number that satisfy the inequality

$$x - 7 \leq \frac{3x-5}{2} < 8.$$

Answer $x = \dots\dots\dots$ [1]

- 12 In the diagram below, ADB is a right-angled triangle with angle $ADB = 90^\circ$ and ACD is a triangle with $AD = 8$ cm and angle $DCA = 30^\circ$. B is a point on AC such that $AB = 10$ cm and $DB = 6$ cm.

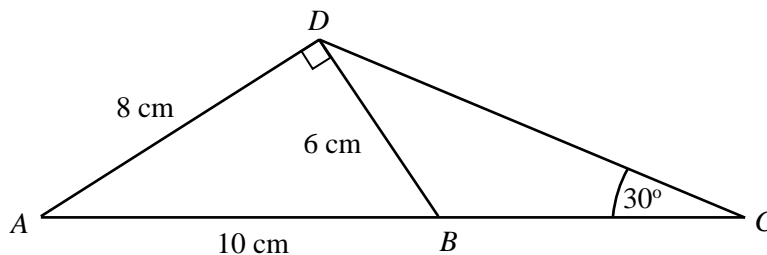

- (a) Write down, as a fraction in its simplest form, the value of $\sin \angle DBC$.

Answer [1]

- (b) Hence, calculate the length of DC .

Answer cm [2]

- 13 Dorothy wants to make a bracelet using gemstones. Every gemstone is a regular pentagon of the same size.

How many gemstones does she need to make a bracelet assuming that there is no gap between each gemstone?

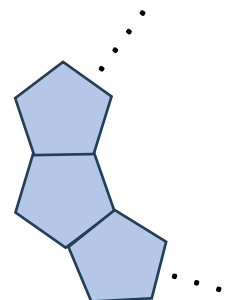

Answer [3]

- 14** Each term in the following sequence is found by multiplying the same constant to the previous term.

$p, \quad 12, \quad q, \quad 48, \quad r, \quad \dots$

- (a) Write down two possible values of q .

Answer $q = \dots\dots\dots$ or $\dots\dots\dots$ [2]

- (b) Write down the value of $\frac{p}{r}$.

Answer $\dots\dots\dots$ [1]

- (c) Write down the n th term of the sequence.

Answer $\dots\dots\dots$ [1]

- (d) Explain why 400 is not a term in this sequence.

.....

.....

..... [1]

- 15** A bag initially contains 6 blue balls, x green balls and y red balls. The probability of drawing a green ball is $\frac{1}{4}$. If 4 blue balls are added into the bag and 1 red ball is removed from the bag, the possibility of drawing a green ball from the bag is $\frac{2}{9}$.
Find the value of x .

Answer $x = \dots\dots\dots$ [4]

- 16 (a)** Construct triangle ABC where $AB = 10$ cm, $BC = 7$ cm and angle $ABC = 60^\circ$.
 AB has already been drawn. [1]

Answer (a), (b), (c) and (d)

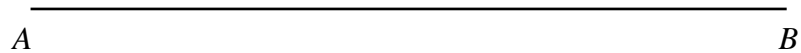

- (b)** Construct the perpendicular bisector of AB . [1]
- (c)** Construct the bisector of angle BAC . [1]
- (d)** Mark clearly a possible point which is inside the triangle, equidistant from the lines AB and AC , and is nearer to point A than point B .
Label this point P . [1]

17 The cumulative frequency graph shows the distribution of the marks of 200 students for a Biology test

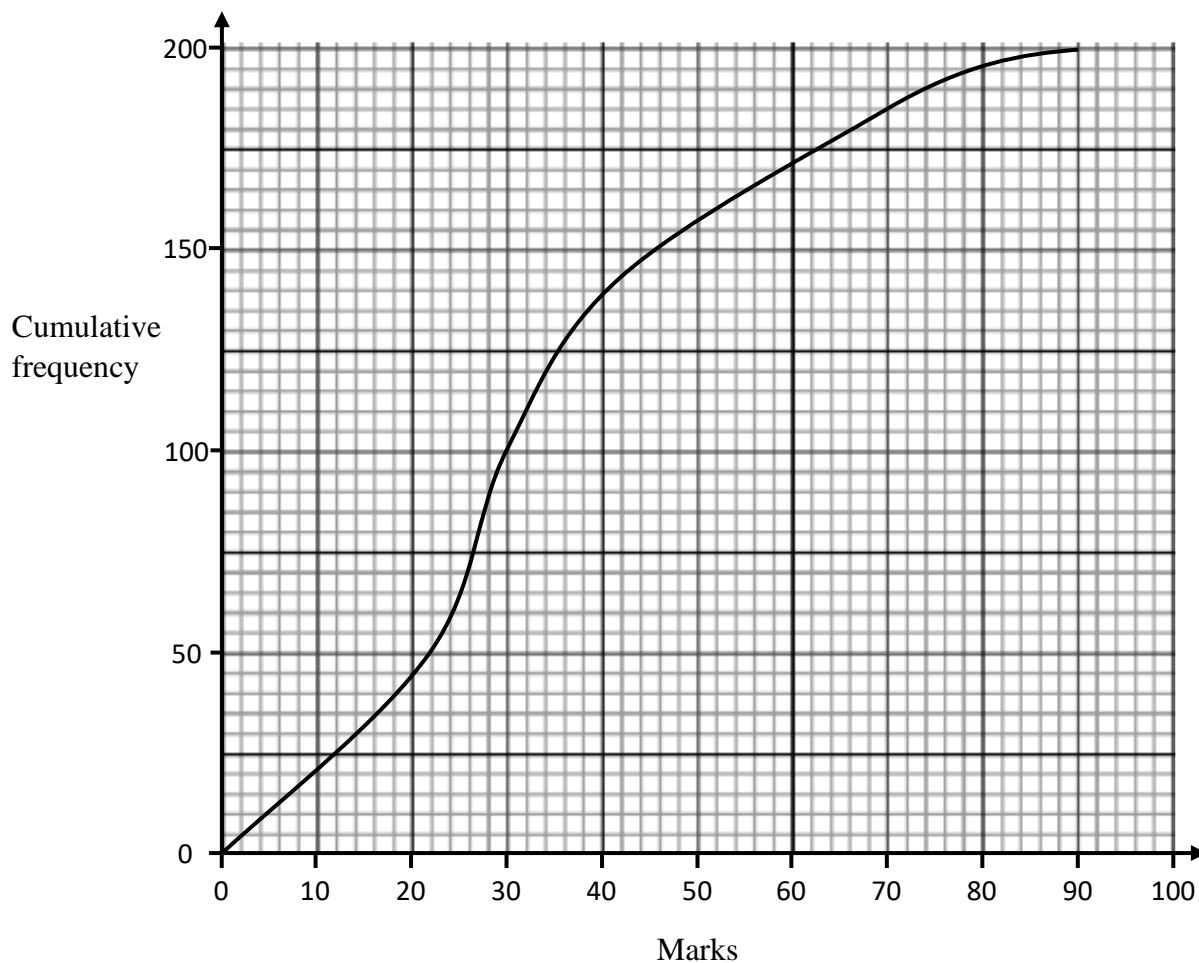

(a) Use the curve to estimate

(i) the median mark for the test,

Answer [1]

(ii) the interquartile range for the test,

Answer [1]

(iii) the percentage of the students scored more than 70 marks for the test.

Answer % [2]

(b) The box-and-whisker plot represents the distribution of marks of the same 200 students for a Chemistry test.

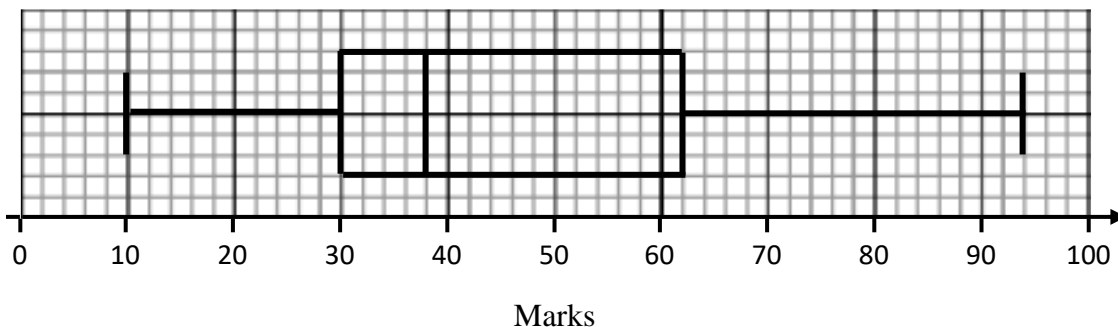

Make two comparisons between the marks for the two tests.

Use figures to support your answers.

1.

.....

..... [1]

2.

.....

..... [1]

- 18 The volumes of two geometrically similar troughs X and Y are 4050 cm^3 and 1200 cm^3 respectively.

Trough X has a height of 75 cm and base area of 162 cm^2 .

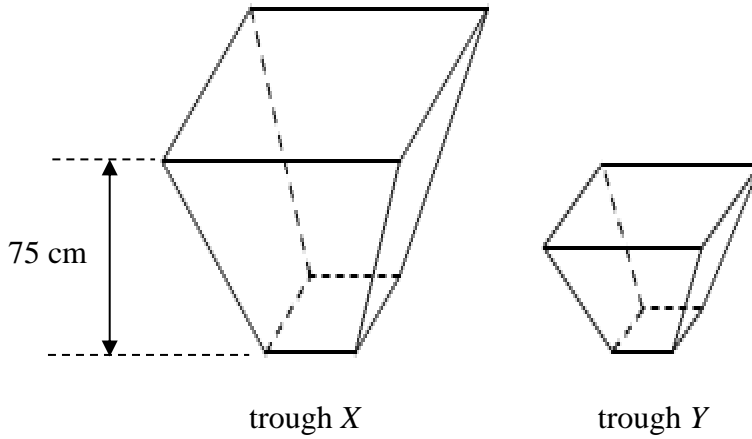

Find

- (a) the height of trough Y ,

Answer cm [2]

- (b) the area of the base of trough Y .

Answer cm^2 [2]

- 19 The diagram shows a square $PQRS$ of side 4 cm. Two quadrants are drawn with P and Q as their centres respectively. The two quadrants intersect at point X .

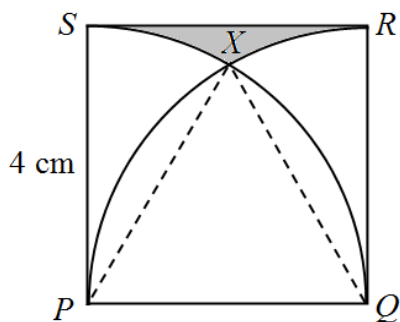

- (a) Catherine said the triangle PXQ is an equilateral triangle. State whether you agree or disagree with Catherine and explain your decision.

I, because

.....

..... [1]

- (b) Find the area of the shaded region SXR .

Answer cm² [3]

- 20 The diagram shows the points A and B where $\overrightarrow{AB} = \begin{pmatrix} -2 \\ -6 \end{pmatrix}$.

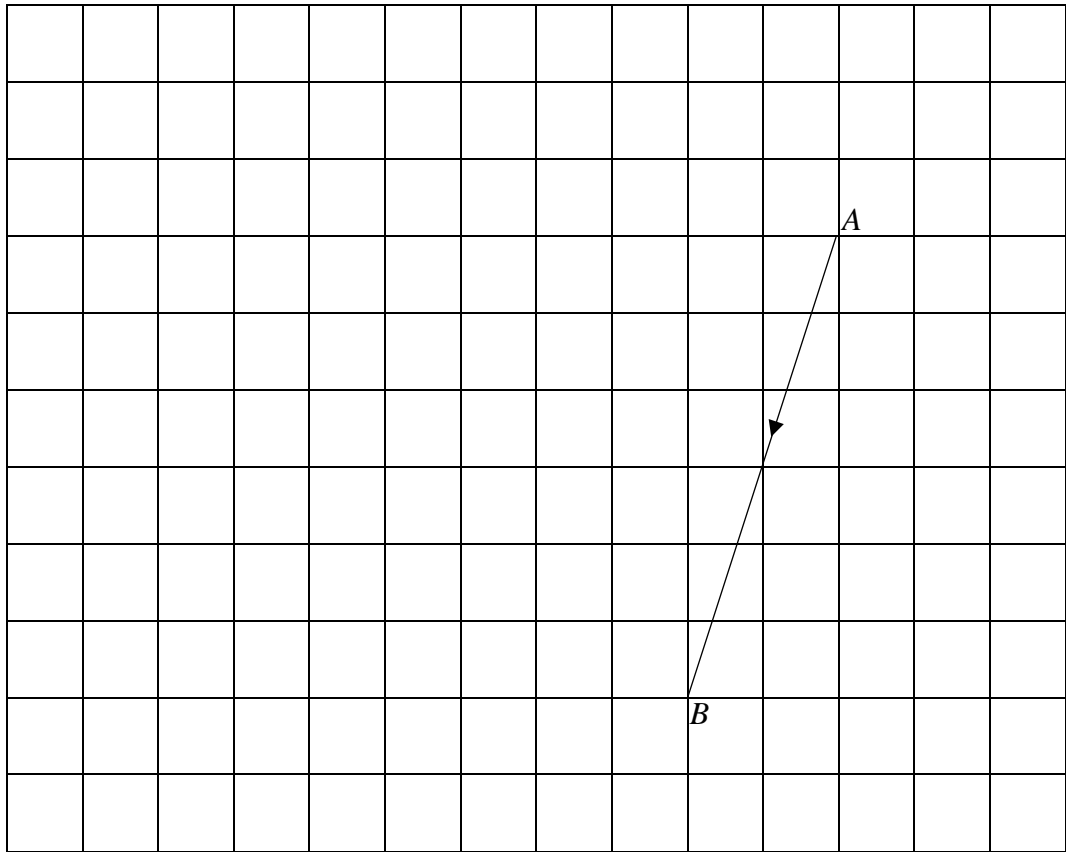

- (a) Given that $\overrightarrow{BC} = \begin{pmatrix} -3 \\ 1 \end{pmatrix}$, mark and label the point C on the diagram. [1]

- (b) D is the point such that $|\overrightarrow{BC}| = |\overrightarrow{CD}|$ and $ABCD$ is a kite. Express \overrightarrow{CD} as a vector.

Answer [1]

- (c) Find $|\overrightarrow{AC}|$.

Answer units [2]

- 21 The graph shows the speed-time graph of a car during a period of 60 seconds. The distance travelled in the first 20 seconds is 250 m.

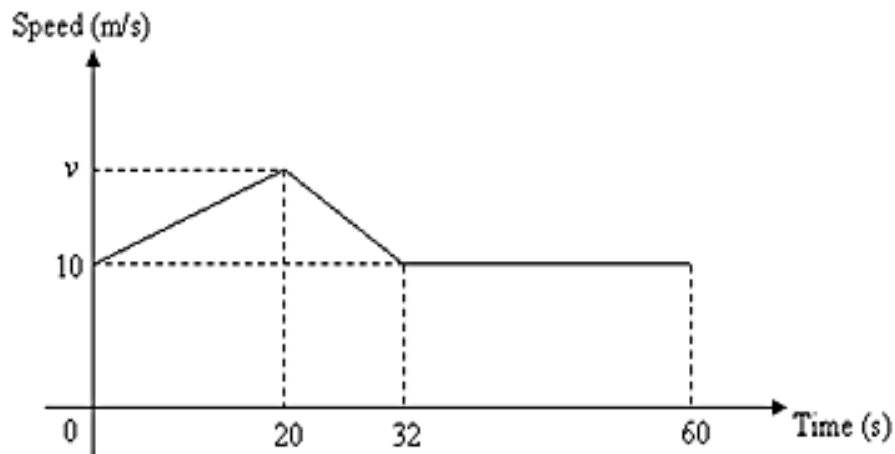

- (a) Show that the maximum speed v is 15 m/s.

Answer

[1]

- (b) Calculate the deceleration during the motion.

Answer m/s² [1]

- (c) Calculate the average speed during the 60 seconds.

Answer m/s [2]

- 22 In the figure below, O is the origin, A is the point $(9, 3)$, B is the point $(6, 0)$ and D is the point $(0, 12)$.

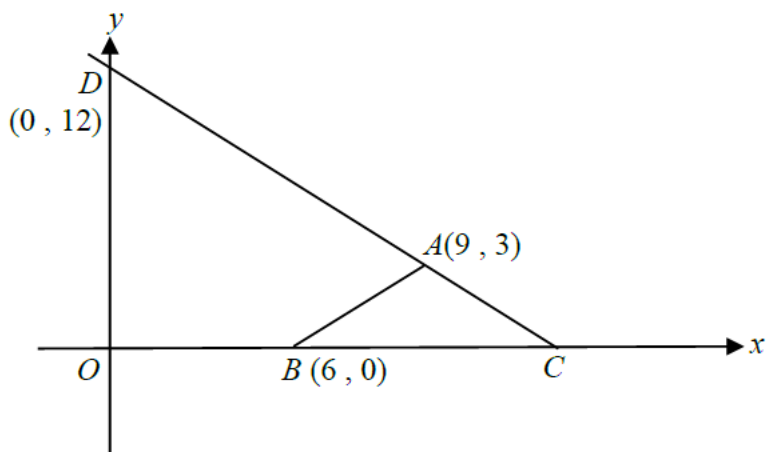

- (a) C is another point on the x -axis such that $AB = AC$.

Find the coordinates of C .

Answer C (.....,) [1]

- (b) Find the equation of line AB .

Answer [2]

- (c) Find the shortest distance from O to the straight line CD .

Answer units [2]

- 23 In the diagram, ABC , CDE and AFE are straight lines. BD is parallel to AE . $BD = 15$ cm, $CD = 12$ cm, $DE = 8$ cm and $EF = 10$ cm.

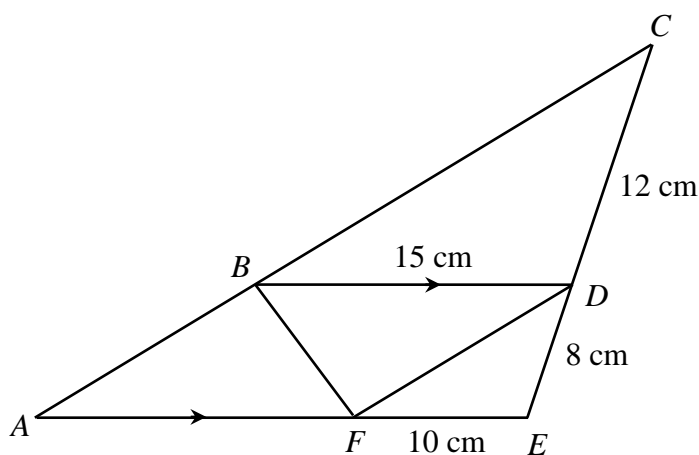

- (a) Show that triangles CDB and DEF are similar.
Give a reason for each statement you make.

.....

 [2]

- (b) Find the ratio of area of triangle CDB : area of triangle DEF .

Answer : [1]

- (c) Show that $ABDF$ is a parallelogram.

.....

 [2]

- 24 The diagram shows a closed L-shaped rectangular structure with dimensions stated.

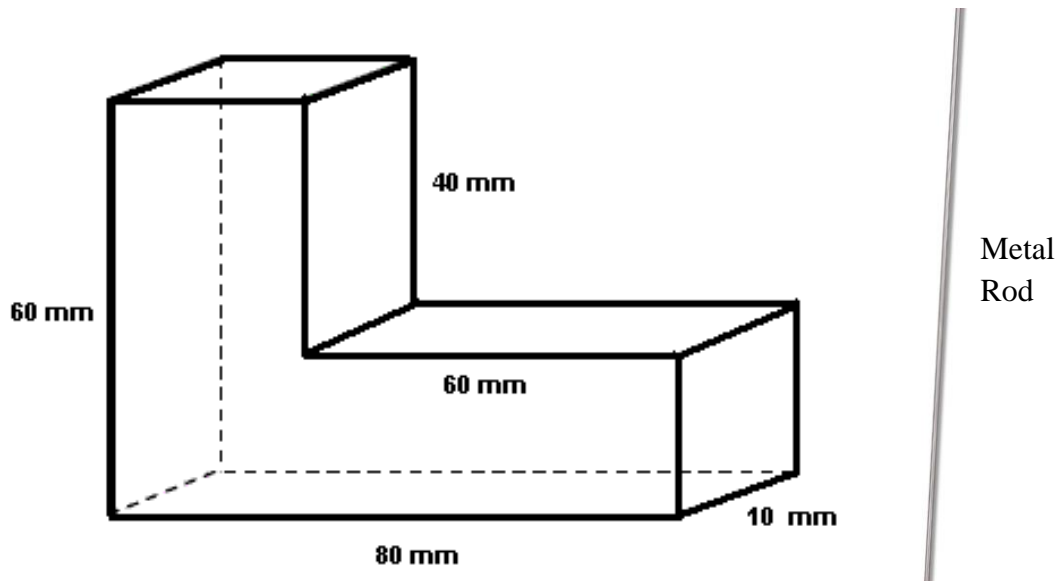

- (a) Calculate the volume of the L-shaped rectangular structure.

Answer mm³ [2]

- (b) Edison wants to put a thin and long metal rod inside the structure. What is the longest length of the metal rod that Edison can put in?

Answer mm [3]

End of Paper



BENDEMEER SECONDARY SCHOOL
2024 PRELIMINARY EXAMINATION
SECONDARY 4 EXPRESS / 5 NORMAL (ACADEMIC)

CANDIDATE
NAME

MARKING SCHEME

CLASS

INDEX
NUMBER

MATHEMATICS

Paper 1

4052/01

20 Aug 2024

2 hours 15 minutes

Candidates answer on the Question Paper.
No additional materials are required.

READ THESE INSTRUCTIONS FIRST

Write your name, class and register number on all the work you hand in.

Write in dark blue or black pen.

You may use an HB pencil for any diagrams or graphs.

Do not use staples, paper clips, glue or correction fluid/tape.

DO NOT WRITE ON ANY BARCODES.

Answer **all** questions.

The number of marks is given in brackets [] at the end of each question or part question.

If working is needed for any question, it must be shown with the answer.

Omission of essential working will result in loss of marks.

The total of the marks for this paper is 90.

The use of an approved scientific calculator is expected, where appropriate.

If the degree of accuracy is not specified in the question, and if the answer is not exact, give the answer to three significant figures. Give answers in degrees to one decimal place.

For π , use either your calculator value or 3.142.

FOR EXAMINER'S USE

90

MATHEMATICAL FORMULAE*Compound Interest*

$$\text{Total amount} = P \left(1 + \frac{r}{100} \right)^n$$

Mensuration

$$\text{Curved surface area of cone} = \pi r l$$

$$\text{Surface area of a sphere} = 4 \pi r^2$$

$$\text{Volume of a cone} = \frac{1}{3} \pi r^2 h$$

$$\text{Volume of sphere} = \frac{4}{3} \pi r^3$$

$$\text{Area of triangle ABC} = \frac{1}{2} ab \sin C$$

$$\text{Arc length} = r\theta, \text{ where } \theta \text{ is in radians}$$

$$\text{Sector area} = \frac{1}{2} r^2 \theta, \text{ where } \theta \text{ is in radians}$$

Trigonometry

$$\frac{a}{\sin A} = \frac{b}{\sin B} = \frac{c}{\sin C}$$

$$a^2 = b^2 + c^2 - 2bc \cos A$$

Statistics

$$\text{Mean} = \frac{\sum fx}{\sum f}$$

$$\text{Standard Deviation} = \sqrt{\frac{\sum fx^2}{\sum f} - \left(\frac{\sum fx}{\sum f} \right)^2}$$

Answer **all** the questions.

1 Factorise each of the following completely.

(a) $4a^2 - b^2$
 $= (2a + b)(2a - b)$ [B1]

Answer [1]

(b) $5x - 1 + 10x^2y - 2x$
 $= (5x - 1) + 2xy(5x - 1)$ [M1]
 $= (5x - 1)(1 + 2xy)$ [A1]

Answer [2]

2 (a) Simplify $(2x^3y)^3$.

$$= 8x^9y^3 \quad \text{[B1]}$$

Answer [1]

- (b) Use the laws of indices to solve the following equation for x . Show your working clearly.

$$2^2 \times 5^3 + \frac{1}{125^x} = 5^4.$$

$$5^{-3x} = 5^4 - 4 \times 5^3$$

$$5^{-3x} = 5^3 \quad \text{[M1]}$$

$$-3x = 3$$

$$x = -1 \quad \text{[A1]}$$

Answer $x = \dots\dots\dots$ [2]

- 3 (a) Express 1176 as a product of its prime factors.

$$= 2^3 \times 3 \times 7^2 \quad \text{[B1]}$$

Answer [1]

- (b) The number $1176k$ is a perfect cube.

Find the smallest positive integer value of k .

$$1176k = 2^3 \times 3 \times 7^2 \times k = 2^3 \times 3^3 \times 7^3$$

$$\therefore k = 63 \quad \text{[B1]}$$

Answer $k =$ [1]

- (c) The highest common factor of two distinct integers, n and 1176, is 28.

Given that $500 < n < 1000$, find the smallest possible value of n .

$$HCF = 28 = 2^2 \times 7$$

$$\therefore n = 2^2 \times 7 \times 19 = 532 \quad \text{[B1]}$$

Answer $n =$ [1]

- 4 The volume of a right pyramid is $4.8 \times 10^{-8} \text{ m}^3$ and its length of the square base is $1.5 \times 10^{-3} \text{ m}$. Giving your answer in standard form, find its height.

$$\frac{1}{3} \times (1.5 \times 10^{-3})^2 \times h = 4.8 \times 10^{-8} \quad \text{[M1]}$$

$$\therefore h = \frac{3 \times 4.8 \times 10^{-8}}{(1.5 \times 10^{-3})^2} = 6.4 \times 10^{-2} \quad \text{[A1]}$$

Answer m [2]

- 5 Benjamin invested \$8000 at a rate of 3.3% per annum compounded monthly. What is the value of his investment at the end of 6 months?

$$A = 8000 \left(1 + \frac{3.3}{12 \times 100}\right)^6 \quad \text{[M1]}$$

$$= \$8132.91 \quad \text{[A1]}$$

Answer \$ [2]

6 (a) In the Venn diagram below, shade the region $P \cup Q'$.

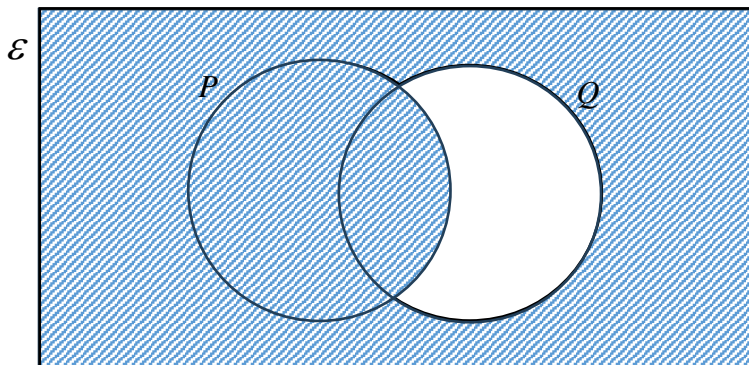

[1]

(b) A universal set ε and its subset A and B are given by

$$\varepsilon = \{x: x \text{ is an integer and } 0 < x < 12\},$$

$$A = \{x: x \text{ is a factor of } 24\},$$

$$B = \{x: 2x - 7 \geq 5\}.$$

(i) Write all the elements of ε in the Venn diagram below.

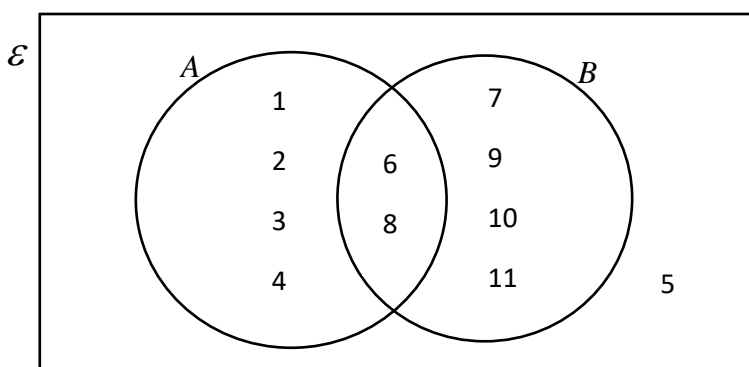

All sections correct [B2]

2 to 3 sections correct [B1]

[2]

(ii) Another number is included in the universal set ε .

This number is in the region $A \cap B$.

Write down a possible value of this number.

12 or 24 [B1]

Answer [1]

7 The expression $2x^2 + 8x + 9$ is equivalent to $2(x + a)^2 + b$.

(a) Find the value of a and the value of b .

$$= 2(x^2 + 4x) + 9$$

$$= 2[(x + 2)^2 - 2^2] + 9$$

$$= 2(x + 2)^2 - 8 + 9$$

$$= 2(x + 2)^2 + 1$$

Hence, $a = 2$ [B1]

And $b = 1$ [B1]

Answer $a = \dots\dots\dots$ [1]

$b = \dots\dots\dots$ [1]

(b) Sketch the curve $y = 2x^2 + 8x + 9$ on the given axes below, clearly showing the y-intercept and the turning point.

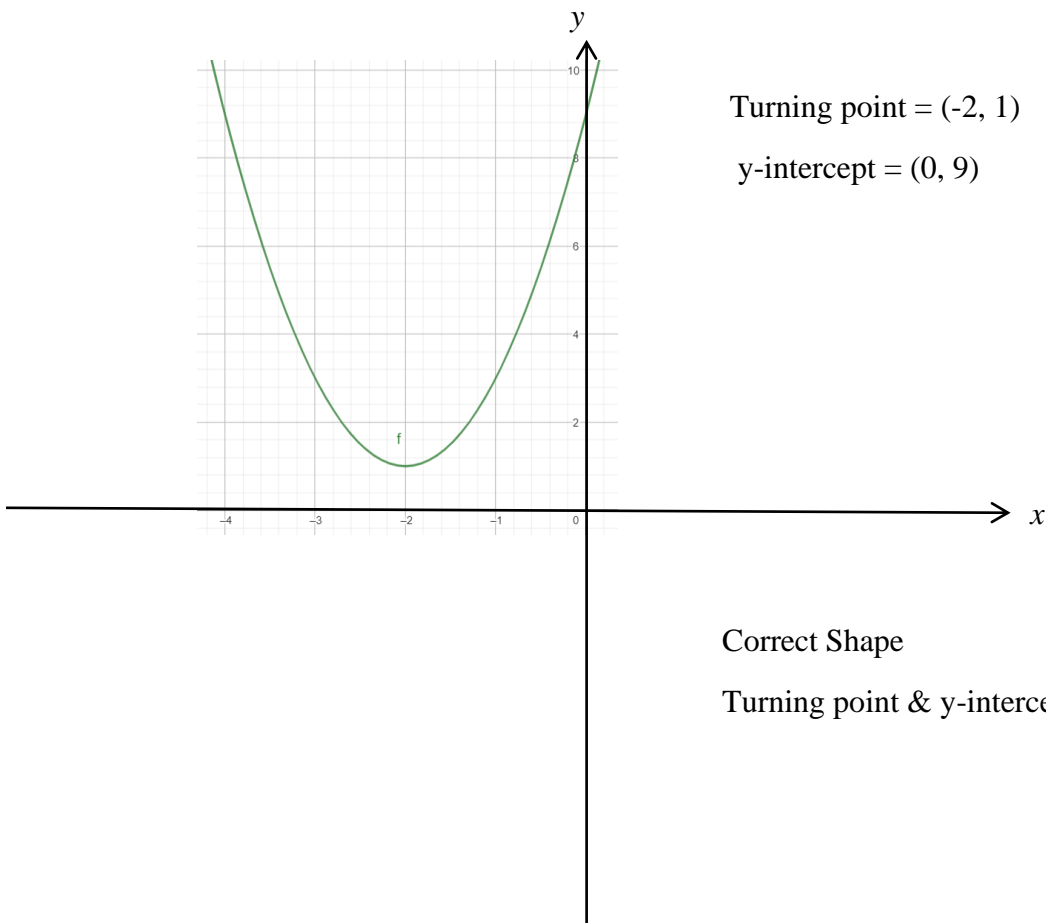

- 8 Given that the formula of y is inversely proportional to the square of $(x + 2)$ and the value of $y = \frac{1}{3}$ when $x = 7$.

- (a) Express y in terms of x .

$$y = \frac{k}{(x + 2)^2}$$

$$\frac{1}{3} = \frac{k}{(7 + 2)^2}$$

$$k = 27 \quad \text{[M1]}$$

$$\therefore y = \frac{27}{(x+2)^2} \quad \text{[A1]}$$

Answer $y = \dots\dots\dots$ [2]

- (b) Hence, or otherwise, make x the subject of the formula.

$$(x + 2)^2 = \frac{27}{y} \quad \text{[M1]}$$

$$x + 2 = \pm \sqrt{\frac{27}{y}}$$

$$\therefore x = -2 \pm \sqrt{\frac{27}{y}} \quad \text{[A1]}$$

Answer $x = \dots\dots\dots$ [2]

- 9 Explain why $(2n + 3)^2 - (4n + 3)(n - 6)$ is a multiple of 3 for all integer values of n .

Answer

$$= 4n^2 + 12n + 9 - (4n^2 + 3n - 24n - 18) \quad \text{[M1]}$$

$$= 33n + 27$$

$$= 3(11n + 9) \quad \text{[A1]}$$

Hence, it is a multiple of 3 for all integer values of n .

.....

.....

[2]

- 10 Simplify $\frac{2x+3}{x^2+3x+2} - \frac{5}{x+1}$ as a single fraction.

$$= \frac{2x+3}{(x+1)(x+2)} - \frac{5}{x+1} \quad \text{[M1]}$$

$$= \frac{2x+3-5(x+2)}{(x+1)(x+2)} \quad \text{[M1]}$$

$$= \frac{2x+3-5x-10}{(x+1)(x+2)}$$

$$= \frac{-3x-7}{(x+1)(x+2)} \quad \text{[A1]}$$

Answer [3]

- 11 (a) Solve the inequality $x - 7 \leq \frac{3x-5}{2} < 8$.

Represent your solution on the number line below.

$$x - 7 \leq \frac{3x-5}{2}$$

$$\frac{3x-5}{2} < 8$$

$$2x - 14 \leq 3x - 5$$

$$3x - 5 < 16$$

$$-9 \leq x \quad \text{[M1]}$$

$$x < 7 \quad \text{[M1]}$$

Hence, $-9 \leq x < 7$

Answer

[A1]

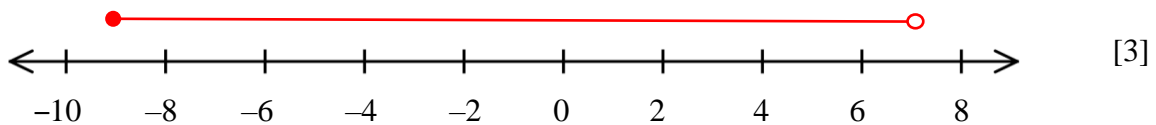

- (b) Hence, write down the largest prime number that satisfy the inequality

$$x - 7 \leq \frac{3x-5}{2} < 8.$$

Largest prime number $x = 5$ [A1]

Answer $x = \dots\dots\dots$ [1]

12

In the diagram below, ADB is a right-angled triangle with angle $ADB = 90^\circ$ and ACD is a triangle with $AD = 8$ cm and angle $DCA = 30^\circ$. B is a point on AC such that $AB = 10$ cm and $DB = 6$ cm.

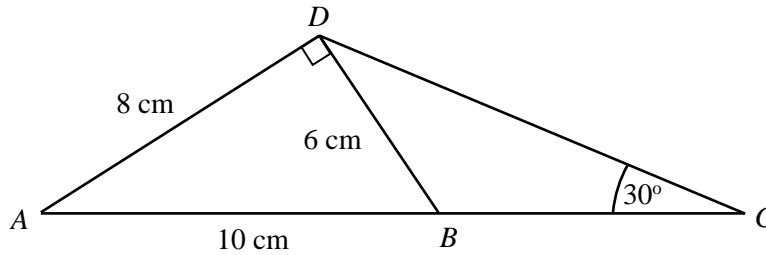

- (a) Write down, as a fraction in its simplest form, the value of $\sin \angle DBC$.

$$\sin \angle DBC = \sin \angle DBA = \frac{8}{10} = \frac{4}{5} \quad \text{[B1]}$$

Answer [1]

- (b) Hence, calculate the length of DC .

$$\frac{DC}{\sin \angle DBC} = \frac{6}{\sin 30^\circ} \quad \text{[M1]}$$

$$\therefore DC = \frac{6}{\sin 30^\circ} \times \frac{4}{5} = 9.6 \text{ cm} \quad \text{[A1]}$$

Answer cm [2]

13

Dorothy wants to make a bracelet using gemstones. Every gemstone is a regular pentagon of the same size.

How many gemstones does she need to make a bracelet assuming that there is no gap between each gemstone?

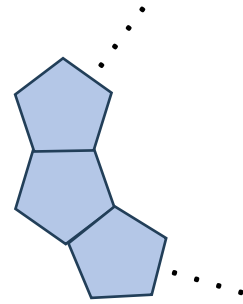

$$\text{Interior angle of each pentagon} = \frac{(5-2)}{5} \times 180^\circ = 108^\circ \quad \text{[M1]}$$

$$\text{So interior angle of polygon inside} = 360^\circ - 108^\circ - 108^\circ = 144^\circ \quad \text{[M1]}$$

$$\therefore \frac{n-2}{n} \times 180^\circ = 144^\circ \quad \text{or} \quad \frac{360^\circ}{n} = 36^\circ$$

$$\therefore n = 10 \quad \text{[A1]}$$

Answer [3]

- 14 Each term in the following sequence is found by multiplying the same constant to the previous term.

$$p, \quad 12, \quad q, \quad 48, \quad r, \quad \dots$$

- (a) Write down two possible values of q .

Let the multiplying constant be x .

$$12x^2 = 48 \quad \text{[M1]}$$

$$x = \pm 2$$

$$\text{Hence } q = 12 \times 2 = 24 \quad \text{or} \quad q = 12 \times (-2) = -24 \quad \text{[A1]}$$

Answer $q = \dots\dots\dots$ or $\dots\dots\dots$ [2]

- (b) Write down the value of $\frac{p}{r}$.

$$\frac{p}{r} = \frac{6}{96} = \frac{1}{16} \quad \text{[B1]}$$

Answer $\dots\dots\dots$ [1]

- (c) Write down the n th term of the sequence.

$$T_n = 6 \times 2^{n-1} \quad \text{or} \quad 3 \times 2^n \quad \text{[B1]}$$

Answer $\dots\dots\dots$ [1]

- (d) Explain why 400 is not a term in this sequence.

(1) $\dots, 48, 96, 192, 384, 768, \dots$

.....

OR (2) $\frac{400}{6} = 66.67$ is not a multiple of 2

.....

Hence, 400 is not a term in this sequence. [B1]

..... [1]

- 15 A bag initially contains 6 blue balls, x green balls and y red balls. The probability of drawing a green ball is $\frac{1}{4}$. If 4 blue balls are added into the bag and 1 red ball is removed from the bag, the possibility of drawing a green ball from the bag is $\frac{2}{9}$.

Find the value of x .

$$\frac{x}{6 + x + y} = \frac{1}{4}$$

$$4x = 6 + x + y$$

$$3x - 6 = y \dots(1) \quad \text{[M1]}$$

$$\frac{x}{10 + x + y - 1} = \frac{2}{9}$$

$$9x = 18 + 2x + 2y$$

$$7x - 18 = 2y \dots(2) \quad \text{[M1]}$$

Solving (1) & (2) simultaneously,

$$7x - 18 = 2(3x - 6) \quad \text{[M1]}$$

$$\therefore x = 6 \quad \text{[A1]}$$

Answer $x = \dots\dots\dots$ [4]

- 16 (a) Construct triangle ABC where $AB = 10$ cm, $BC = 7$ cm and angle $ABC = 60^\circ$. AB has already been drawn. [1]

Answer (a), (b), (c) and (d)

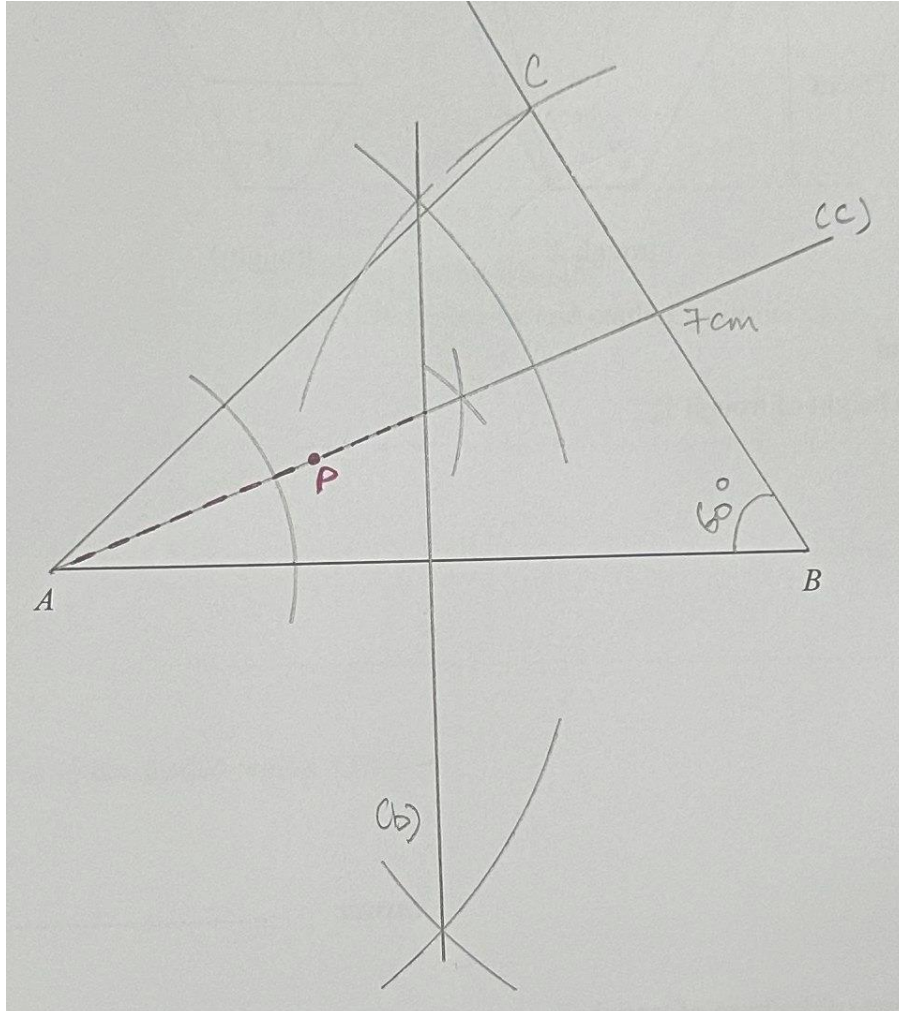

[B1 × 4]

- (b) Construct the perpendicular bisector of AB . [1]
- (c) Construct the bisector of angle BAC . [1]
- (d) Mark clearly a possible point which is inside the triangle, equidistant from the lines AB and AC , and is nearer to point A than point B . Label this point P . [1]

17 The cumulative frequency graph shows the distribution of the marks of 200 students for a Biology test

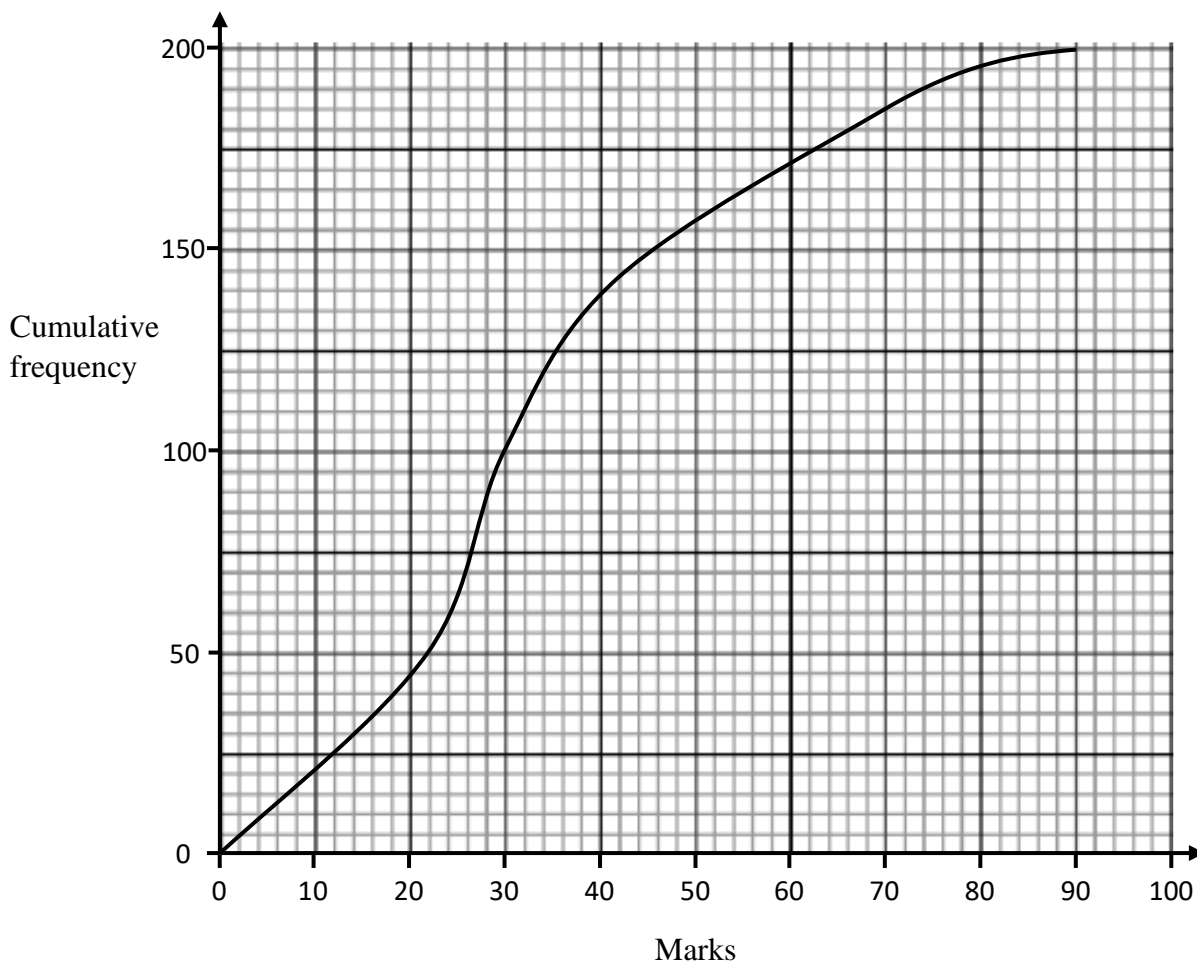

(a) Use the curve to estimate

(i) the median mark for the test,

Median = 30 [B1]

Answer [1]

(ii) the interquartile range for the test,

IQR = 46 – 22 = 24 [B1]

Answer [1]

(iii) the percentage of the students scored more than 70 marks for the test.

$\frac{200-185}{200} \times 100\%$ [M1]

= 7.5% [A1]

Answer % [2]

- (b) The box-and-whisker plot represents the distribution of marks of the same 200 students for a Chemistry test.

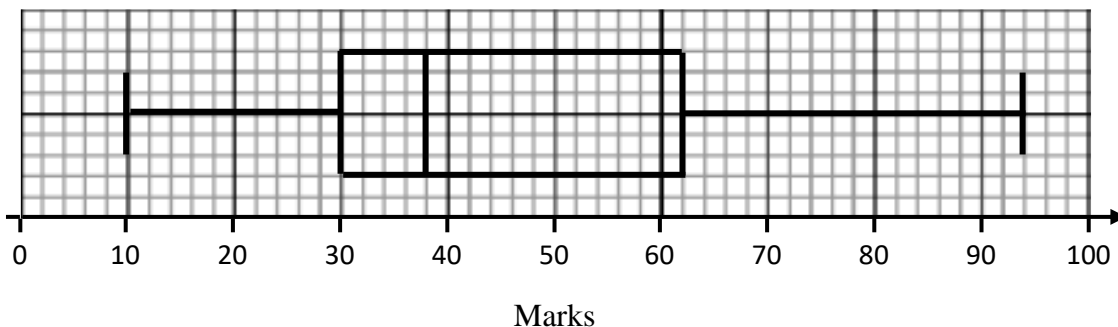

Make two comparisons between the marks for the two tests.

Use figures to support your answers.

Students did better in Chemistry test on average since the median of Chemistry

1.
 (38) is greater than the median of Biology (30). [A1]

..... [1]

Students have more consistent marks in Biology test since the IQR of Biology

2.
 (24) is smaller than the IQR of Chemistry (32). [A1]

..... [1]

- 18 The volumes of two geometrically similar troughs X and Y are 4050 cm^3 and 1200 cm^3 respectively.

Trough X has a height of 75 cm and base area of 162 cm^2 .

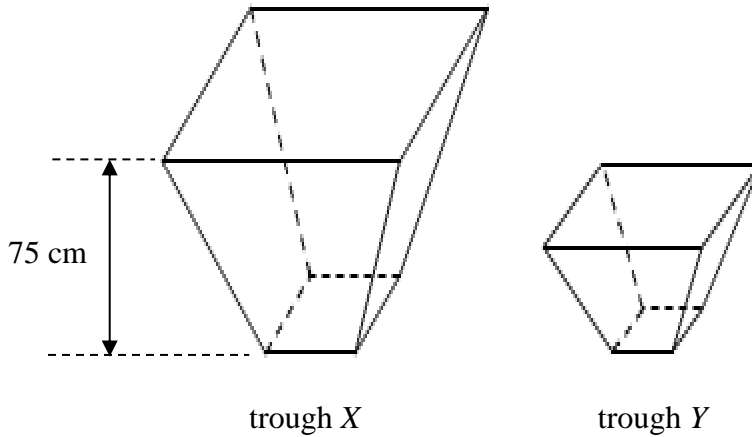

Find

- (a) the height of trough Y ,

$$\frac{h_y}{75} = \sqrt[3]{\frac{1200}{4050}} \quad \text{[M1]}$$

$$\therefore h_y = \frac{2}{3} \times 75 = 50 \text{ cm} \quad \text{[A1]}$$

Answer cm [2]

- (b) the area of the base of trough Y .

$$\frac{A_y}{162} = \left(\frac{2}{3}\right)^2 \quad \text{[M1]}$$

$$\therefore A_y = \frac{4}{9} \times 162 = 72 \text{ cm}^2 \quad \text{[A1]}$$

Answer cm^2 [2]

- 19 The diagram shows a square $PQRS$ of side 4 cm. Two quadrants are drawn with P and Q as their centres respectively. The two quadrants intersect at point X .

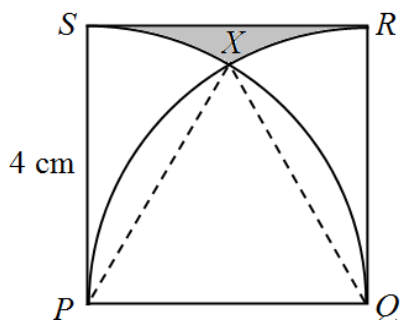

- (a) Catherine said the triangle PXQ is an equilateral triangle. State whether you agree or disagree with Catherine and explain your decision.

agree $PX = QX = PQ =$ radius of the two same size quadrants. [B1]

I, because

.....

..... [1]

- (b) Find the area of the shaded region SXR .

Area of square $- 2(\text{Area of sector } SPX) - \text{Area of triangle } PXQ$

$$= 4 \times 4 - 2 \left(\frac{30^\circ}{360^\circ} \times \pi \times 4^2 \right) - \frac{1}{2} \times 4^2 \times \sin 60^\circ \quad \text{[M2]}$$

$$= 0.694 \text{ cm}^2 \quad \text{[A1]}$$

Answer cm² [3]

20 The diagram shows the points A and B where $\overrightarrow{AB} = \begin{pmatrix} -2 \\ -6 \end{pmatrix}$.

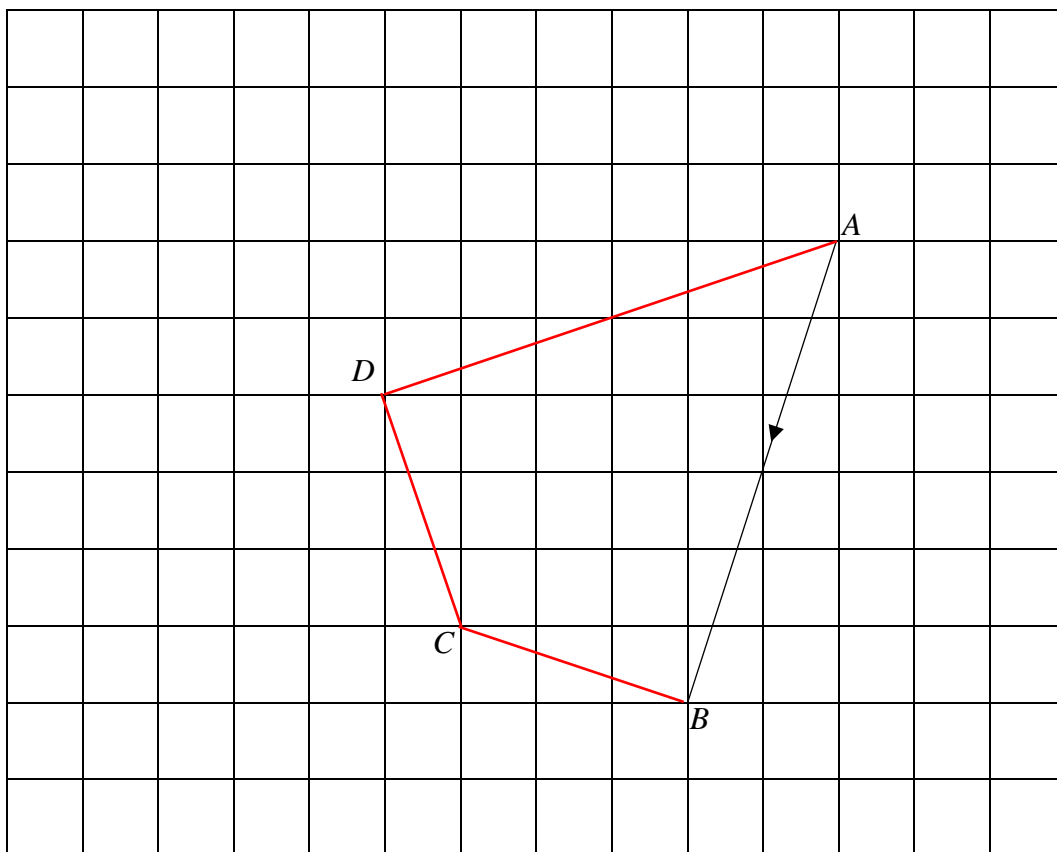

(a) Given that $\overrightarrow{BC} = \begin{pmatrix} -3 \\ 1 \end{pmatrix}$, mark and label the point C on the diagram. [1]

Point C in grid above [B1]

(b) D is the point such that $|\overrightarrow{BC}| = |\overrightarrow{CD}|$ and $ABCD$ is a kite. Express \overrightarrow{CD} as a vector.

$\overrightarrow{CD} = \begin{pmatrix} -1 \\ 3 \end{pmatrix}$ [B1]

Answer [1]

(c) Find $|\overrightarrow{AC}|$.

$|\overrightarrow{AC}| = \sqrt{(-5)^2 + (-5)^2}$ [M1]
 $= 7.07$ [A1]

Answer units [2]

- 21 The graph shows the speed-time graph of a car during a period of 60 seconds. The distance travelled in the first 20 seconds is 250 m.

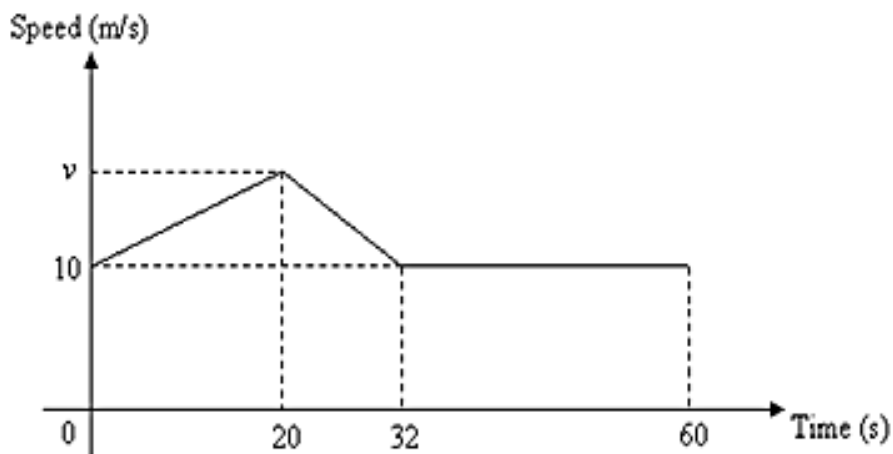

- (a) Show that the maximum speed v is 15 m/s.

Answer

$$\frac{1}{2}(10 + v) \times 20 = 250 \quad \text{[M1]}$$

Hence, $v = 15 \text{ m/s}$

[1]

- (b) Calculate the deceleration during the motion.

$$\text{Gradient} = \frac{15 - 10}{20 - 32} = -\frac{5}{12}$$

$$\therefore \text{deceleration} = \frac{5}{12} \text{ or } 0.417 \text{ m/s}^2 \quad \text{[B1]}$$

Answer m/s² [1]

- (c) Calculate the average speed during the 60 seconds.

$$\text{Total distance} = 250 + \frac{1}{2}(15 + 10) \times 12 + 28 \times 10 = 680 \text{ m} \quad \text{[M1]}$$

$$\therefore \text{average speed} = \frac{680}{60} = 11\frac{1}{3} \text{ m/s} \quad \text{[A1]}$$

Answer m/s [2]

- 22 In the figure below, O is the origin, A is the point $(9, 3)$, B is the point $(6, 0)$ and D is the point $(0, 12)$.

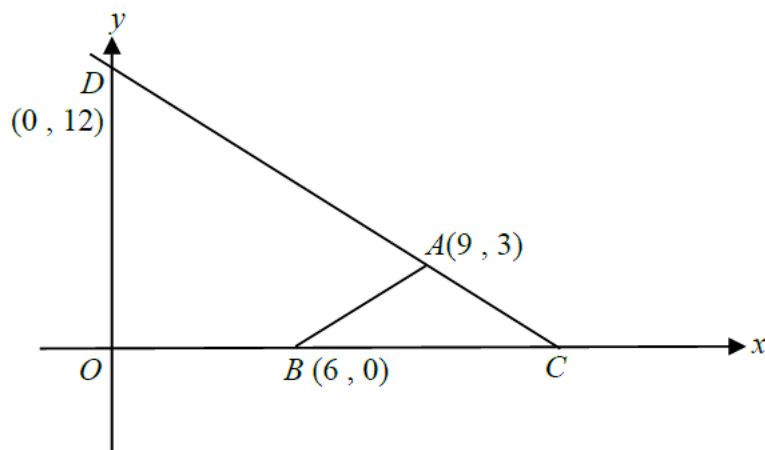

- (a) C is another point on the x -axis such that $AB = AC$.

Find the coordinates of C .

$$C = (12, 0) \quad \text{[B1]}$$

Answer C (.....,) [1]

- (b) Find the equation of line AB .

$$\text{Gradient} = \frac{3-0}{9-6} = 1 \quad \text{[M1]}$$

$$\therefore \text{equation of } AB \text{ is } y = x - 6. \quad \text{[A1]}$$

Answer [2]

- (c) Find the shortest distance from O to the straight line CD .

$$CD = \sqrt{12^2 + 12^2} = 16.97 \quad \text{[M1]}$$

$$\frac{1}{2} \times 16.97 \times h = \frac{1}{2} \times 12 \times 12$$

$$\therefore h = 8.49 \text{ (correct to 3 s.f.)} \quad \text{[A1]}$$

Answer units [2]

- 23 In the diagram, ABC , CDE and AFE are straight lines. BD is parallel to AE . $BD = 15$ cm, $CD = 12$ cm, $DE = 8$ cm and $EF = 10$ cm.

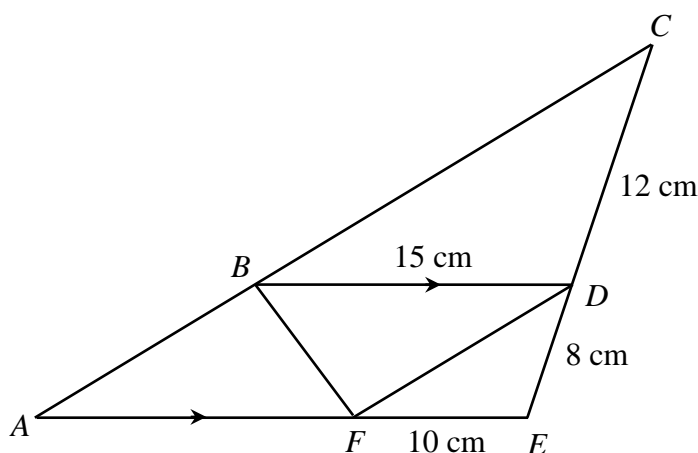

- (a) Show that triangles CDB and DEF are similar. Give a reason for each statement you make.

$\angle BDC = \angle FED$ (corresponding \angle s, $BD \parallel AE$), $\frac{BD}{FE} = \frac{15}{10} = \frac{3}{2}$ and $\frac{CD}{DE} = \frac{12}{8} = \frac{3}{2}$

[B1]

$\therefore \triangle CDB$ and $\triangle DEF$ are similar. (Ratio of corr sides and included angle are equal / SAS similarity test) [B1]

[2]

- (b) Find the ratio of area of triangle CDB : area of triangle DEF .

$(12:8)^2 = 9:4$ [B1]

Answer : [1]

- (c) Show that $ABDF$ is a parallelogram.

$\angle CBD = \angle DFE$ (from part (a) $\triangle CDB$ and $\triangle DEF$ are similar) [B1]

$\angle BAF = \angle CBD$ (corresponding \angle s, $BD \parallel AE$) and so $\angle BAF = \angle DFE$ [B1]

$\therefore AB \parallel FD$ and hence $ABDF$ is a parallelogram.

[2]

24

The diagram shows a closed L-shaped rectangular structure with dimensions stated.

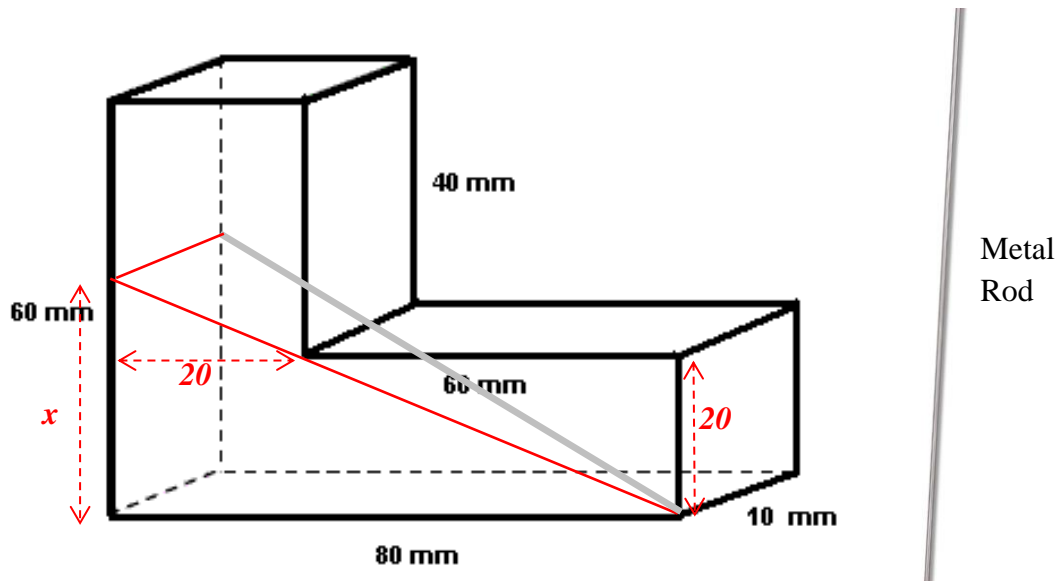

- (a) Calculate the volume of the L-shaped rectangular structure.

$$= 80 \times 20 \times 10 + 40 \times 20 \times 10 \quad \text{[M1]}$$

$$= 24\,000 \text{ mm}^3 \quad \text{[A1]}$$

Answer mm³ [2]

- (b) Edison wants to put a thin and long metal rod inside the structure.
What is the longest length of the metal rod that Edison can put in?

$$\frac{x}{20} = \frac{80}{60} \quad (\text{similar triangles})$$

$$x = 26\frac{2}{3} \quad \text{[M1]}$$

$$l = \sqrt{\left(26\frac{2}{3}\right)^2 + 80^2 + 10^2} \quad (\text{pythagoras theorem}) \quad \text{[M1]}$$

$$\therefore \text{longest length of metal rod, } l = 84.9 \text{ mm} \quad \text{[A1]}$$

Answer mm [3]

End of Paper



BENDEMEER SECONDARY SCHOOL
2024 PRELIMINARY EXAMINATION
SECONDARY 4 EXPRESS / 5 NORMAL (ACADEMIC)

CANDIDATE
NAME

CLASS

INDEX
NUMBER

MATHEMATICS

Paper 2

4052/02

21 August 2024

2 hours 15 minutes

Candidates answer on the Question Paper.
No additional materials are required.

READ THESE INSTRUCTIONS FIRST

Write your name, class and register number on all the work you hand in.
Write in dark blue or black pen.
You may use an HB pencil for any diagrams or graphs.
Do not use staples, paper clips, highlighters, glue or correction fluid.
DO NOT WRITE ON ANY BARCODES.

Answer **all** the questions.
The number of marks is given in brackets [] at the end of each question or part question.

If working is needed for any question, it must be shown with the answer.
Omission of essential working will result in loss of marks.
The total number of marks for this paper is 90.

The use of an approved scientific calculator is expected, where appropriate.
If the degree of accuracy is not specified in the question, and if the answer is not exact, give the answer to three significant figures. Give answers in degrees to one decimal place.
For π , use either your calculator value or 3.142.

FOR EXAMINER'S USE
90

MATHEMATICAL FORMULAE*Compound Interest*

$$\text{Total amount} = P \left(1 + \frac{r}{100} \right)^n$$

Mensuration

$$\text{Curved surface area of cone} = \pi r l$$

$$\text{Surface area of a sphere} = 4 \pi r^2$$

$$\text{Volume of a cone} = \frac{1}{3} \pi r^2 h$$

$$\text{Volume of sphere} = \frac{4}{3} \pi r^3$$

$$\text{Area of triangle ABC} = \frac{1}{2} ab \sin C$$

$$\text{Arc length} = r\theta, \text{ where } \theta \text{ is in radians}$$

$$\text{Sector area} = \frac{1}{2} r^2 \theta, \text{ where } \theta \text{ is in radians}$$

Trigonometry

$$\frac{a}{\sin A} = \frac{b}{\sin B} = \frac{c}{\sin C}$$

$$a^2 = b^2 + c^2 - 2bc \cos A$$

Statistics

$$\text{Mean} = \frac{\sum fx}{\sum f}$$

$$\text{Standard Deviation} = \sqrt{\frac{\sum fx^2}{\sum f} - \left(\frac{\sum fx}{\sum f} \right)^2}$$

- 1 (a) Simplify $\left(\frac{3a^{-\frac{3}{2}}b^2}{4^{\frac{1}{2}}b^3}\right)^{-2}$ and leave your answer in positive index notation.

Answer (a) _____ [3]

- (b) Simplify $\frac{(a-5b)^2}{a^2-25b^2} \div \frac{a-5b}{5b}$.

Answer (b) _____ [2]

- 2 The diagram below shows a Tchoukball court of dimension 27m by 16m. On each end is a semicircle of radius 3m. The shaded part is to be painted yellow.

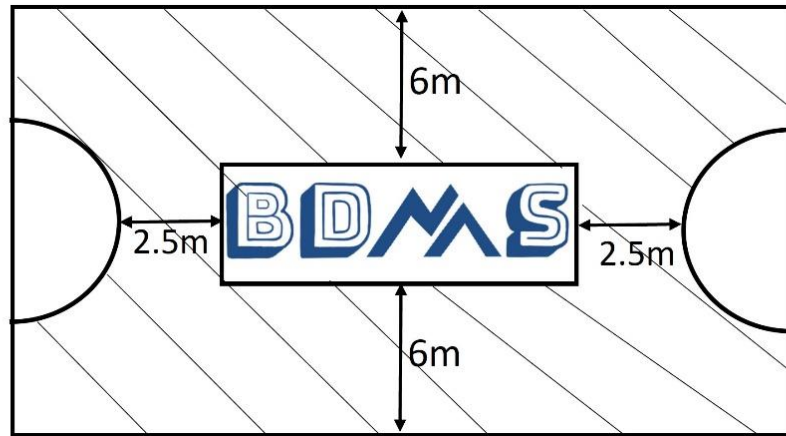

- (a) Find the area of the court that is painted yellow.

Answer (a) _____m² [2]

- (b) 3 workers can paint the court in 5 days. After painting the first day, the workers had to stop on the second and third day because it was raining. Teachers, Mr Chin and Mr Lee, decided to help with the painting on the fourth and fifth day.
- Assuming the 3 workers and 2 teachers paint at the same rate, can they finish painting the shaded area on the fifth day?
- Show your working clearly. [3]

- 3 (a) In the diagram, $\angle ABD = \angle CBD$ and $\angle BAD = \angle BCD$.
Prove that $\triangle ABD$ and $\triangle CBD$ are congruent.

[3]

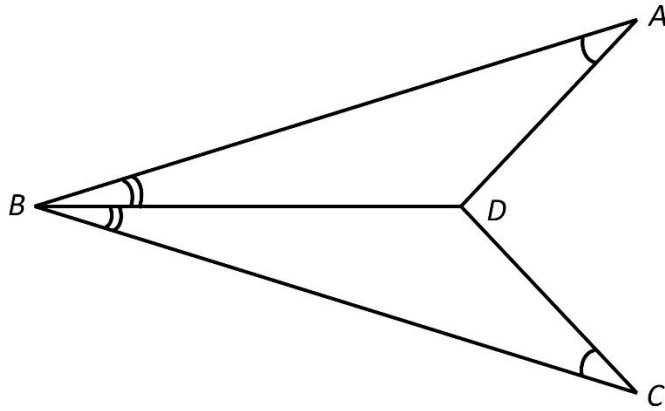

- (b) In the diagram below, O is the centre of the circle and BDG is a straight line. PQ is a tangent to the circles at A and H respectively. $\angle ABD = 27^\circ$ and $\angle DEF = 153^\circ$.

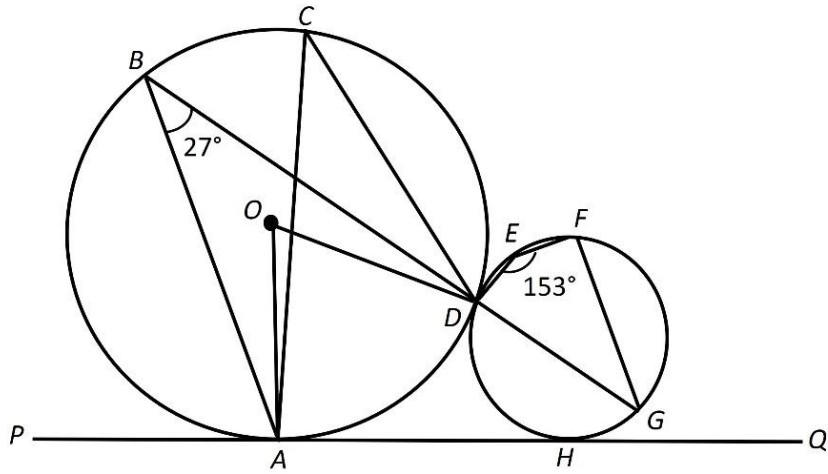

Stating the angle properties of circles clearly, find

- (i) $\angle ACD$

[1]

Answer (i) _____^o

- (ii) $\angle DAH$

[2]

Answer (ii) _____^o

- (iii) Is BA parallel to FG ? Justify your answer clearly with working.

[3]

- 4 Starkids Centre is organising a talent competition for children. Children can choose to compete in 3 categories – singing, dancing and acting.

Matrix **E** shows the number of boys and girls in each category for the age group 5 to 8 years old.

$$\mathbf{E} = \begin{array}{cc} \text{Boys} & \text{Girls} \\ \begin{pmatrix} 5 & 8 \\ 7 & 4 \\ 6 & 7 \end{pmatrix} & \begin{array}{l} \text{Singing} \\ \text{Dancing} \\ \text{Acting} \end{array} \end{array}$$

Matrix **F** shows the number of boys and girls in each category for the age group 9 to 12 years old.

$$\mathbf{F} = \begin{array}{cc} \text{Boys} & \text{Girls} \\ \begin{pmatrix} 12 & 9 \\ 8 & 10 \\ 15 & 11 \end{pmatrix} & \begin{array}{l} \text{Singing} \\ \text{Dancing} \\ \text{Acting} \end{array} \end{array}$$

- (a) Evaluate the matrix $\mathbf{T} = \mathbf{E} + \mathbf{F}$.

Answer (a) $\mathbf{T} =$ _____ [1]

- (b) Each child is charged a registration fee for the competition. The registration is \$30 for singing, \$25 for dancing and \$22 for acting. Represent the fees in a 1 x 3 matrix **C**.

Answer (b) $\mathbf{C} =$ _____ [1]

- (c) Evaluate the matrix $\mathbf{M} = \mathbf{CT}$ and state what the elements in matrix \mathbf{M} represent.

Answer (c) $\mathbf{M} =$ _____ [2]

_____ [1]

- (d) Using matrix multiplication, calculate the total amount of registration fees collected for this competition.

Answer (d) \$ _____ [2]

- (e) Starkids Centre decides to organise a similar competition for teenagers aged 13 to 18 years old. As compared to the competition for children aged 5 to 8 years old, the registration fees for teenagers is increased by 10% for singing, 20% for dancing and 15% for acting.

Using matrix multiplication, calculate the registration fees for teenagers for each category. Give your answer in matrix form.

Answer (e) _____ [2]

- 5 In the diagram, M is the midpoint of OA .
 $\overrightarrow{OA} = \mathbf{a}$, $\overrightarrow{OB} = \mathbf{b}$, $\overrightarrow{AP} = -\frac{1}{2}\mathbf{a} + \frac{5}{6}\mathbf{b}$ and $BN : NA = 3 : 5$.

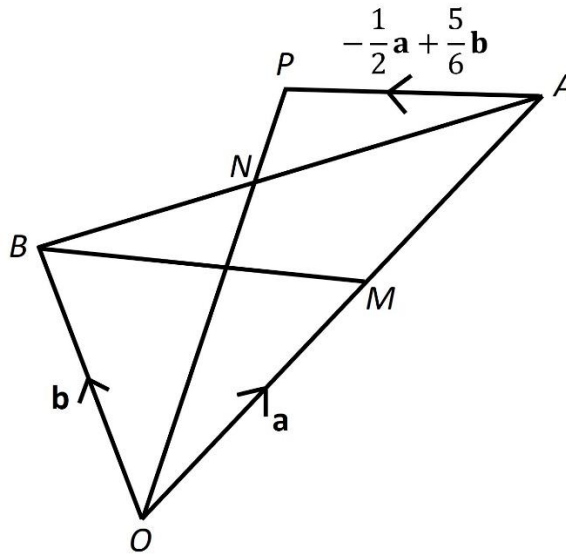

- (a) Express, as simply as possible, in terms of \mathbf{a} and/or \mathbf{b} ,
- (i) \overrightarrow{BN}
 - (ii) \overrightarrow{BM}
 - (iii) \overrightarrow{NM}

Answer (a) (i) _____ [1]
 (ii) _____ [1]
 (iii) _____ [2]

- (b) Find $\frac{\text{Area of } \triangle OBM}{\text{Area of } \triangle OBA}$

Answer (b) _____ [1]

- (c) If $ONAC$ is a parallelogram, find \overrightarrow{CA}

Answer (c) _____ [2]

- (d) Given that $\frac{OP}{ON} = k$, find the value of k .

Answer (d) $k =$ _____ [3]

- 6 The diagram represents the cross-section of a tunnel where AC is on level ground and B is the highest point of the tunnel. The height of the tunnel is 6m and $AC = 5\text{m}$.

(a) Show that radius of the tunnel, $r = 3.5\text{m}$, corrected to 2 significant figures. [2]

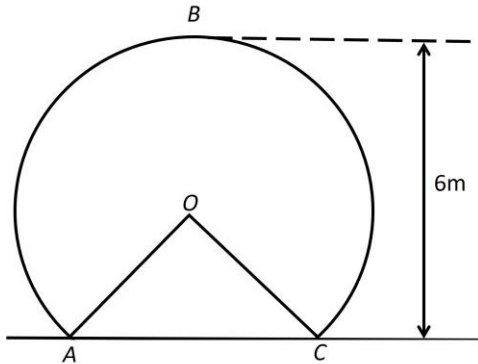

(b) During a flood, water in the tunnel rose up to EF , 0.3m above ground level.

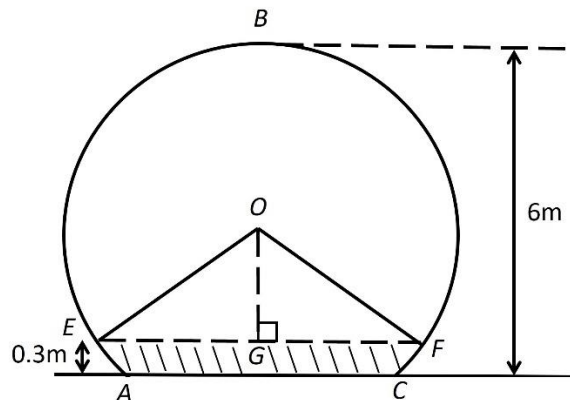

(i) Find $\angle EOF$.

Answer (b) (i) _____ radian [2]

- (ii) Find the length of the major arc EBF .

Answer (ii) _____m [2]

- (iii) Find the cross-section area of the tunnel which is dry.

Answer (iii) _____m² [3]

- (iv) Given that the length of the tunnel is 1.4km, find the volume of the tunnel which is dry.

Answer (iv) _____m³ [2]

- 7 The diagram shows a park $ABCD$ on horizontal ground. DB represents a pebbled path. $AB = 180\text{m}$, $BC = 220\text{m}$, $CD = 310\text{m}$ and $DA = 150\text{m}$. $\angle DAB = 135^\circ$ and $\angle DBC = 76^\circ$.

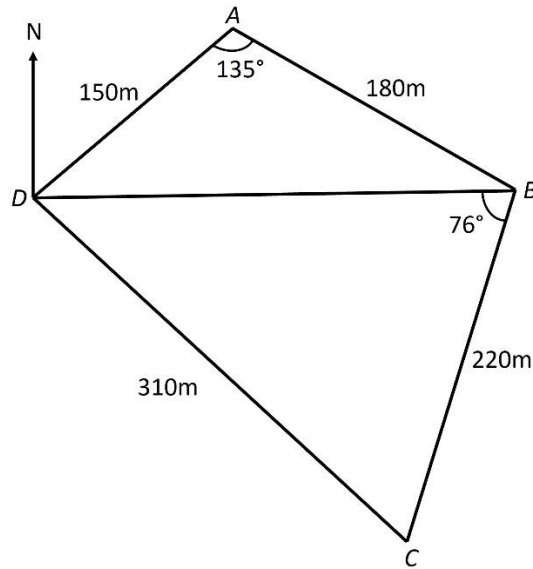

- (a) Find the distance of the pebbled path DB .

Answer (a) _____ m [2]

- (b) Find $\angle BDC$.

Answer (b) _____⁰ [2]

- (c) Find the shortest distance from A to DB .

Answer (c) _____ m [3]

- (d) A lamp post, 12m, is erected vertically at A . Find the greatest angle of elevation of the top of the lamp post from DB .

Answer (d) _____⁰ [2]

- (e) Given that B is due east of D , find the bearing of D from C .

Answer (e) _____ [2]

- 8** In July, the price of durians was $\$x$ per kg.
In August, the price of durians dropped by $\$4.50$ per kg.
Don could buy 2.8 kg more durians in August than in July with $\$200$.

- (a) Write down an expression, in terms of x , to show the mass of durians that can be bought for $\$200$ in July.

Answer (a) _____kg [1]

- (b) Write down an expression, in terms of x , to show the mass of durians that can be bought for $\$200$ in August.

Answer (b) _____kg [1]

- (c) Form an equation in terms of x and show that it reduces to $14x^2 - 63x - 4500 = 0$. [3]

- (d) Solve the equation $14x^2 - 63x - 4500 = 0$. Give your answers corrected to 2 decimal places.

Answer (d) $x =$ _____ or _____ [3]

- (e) Find the price of the durians per kg in August.

Answer (e) \$ _____ [1]

- (f) Find the percentage drop in price in August compared to July.

Answer (f) _____ % [1]

- 9 The variables x and y are connected by the equation $y = \frac{1}{2}x^3 + \frac{1}{5x}$.

Some corresponding values of x and y , correct to 1 decimal place, are given in the table below.

x	-3	-2	-1	-0.5	-0.1	0.1	0.5	1	2	3
y	-13.6	p	-0.7	-0.5	-2.0	2.0	0.5	0.7	4.1	13.6

- (a) Calculate the value of p .

Answer (a) $p =$ _____ [1]

- (b) On the axes given on Page 19, draw the graph of $y = \frac{1}{2}x^3 + \frac{1}{5x}$. [2]

- (c) Using your graph, find the y when $x = -2.4$.

Answer (c) $y =$ _____ [1]

- (d) By drawing a tangent, find the gradient of the curve at $x = 2$.

Answer (d) _____ [2]

- (e) By drawing a suitable straight line, find the solution of $\frac{1}{2}x^3 + \frac{1}{5x} + 2.5x + 5 = 0$.

Answer (e) $x =$ _____ [2]

- (f) Explain why the curve does not touch the y -axis.

Answer (f) _____ [1]

Answer (9b)

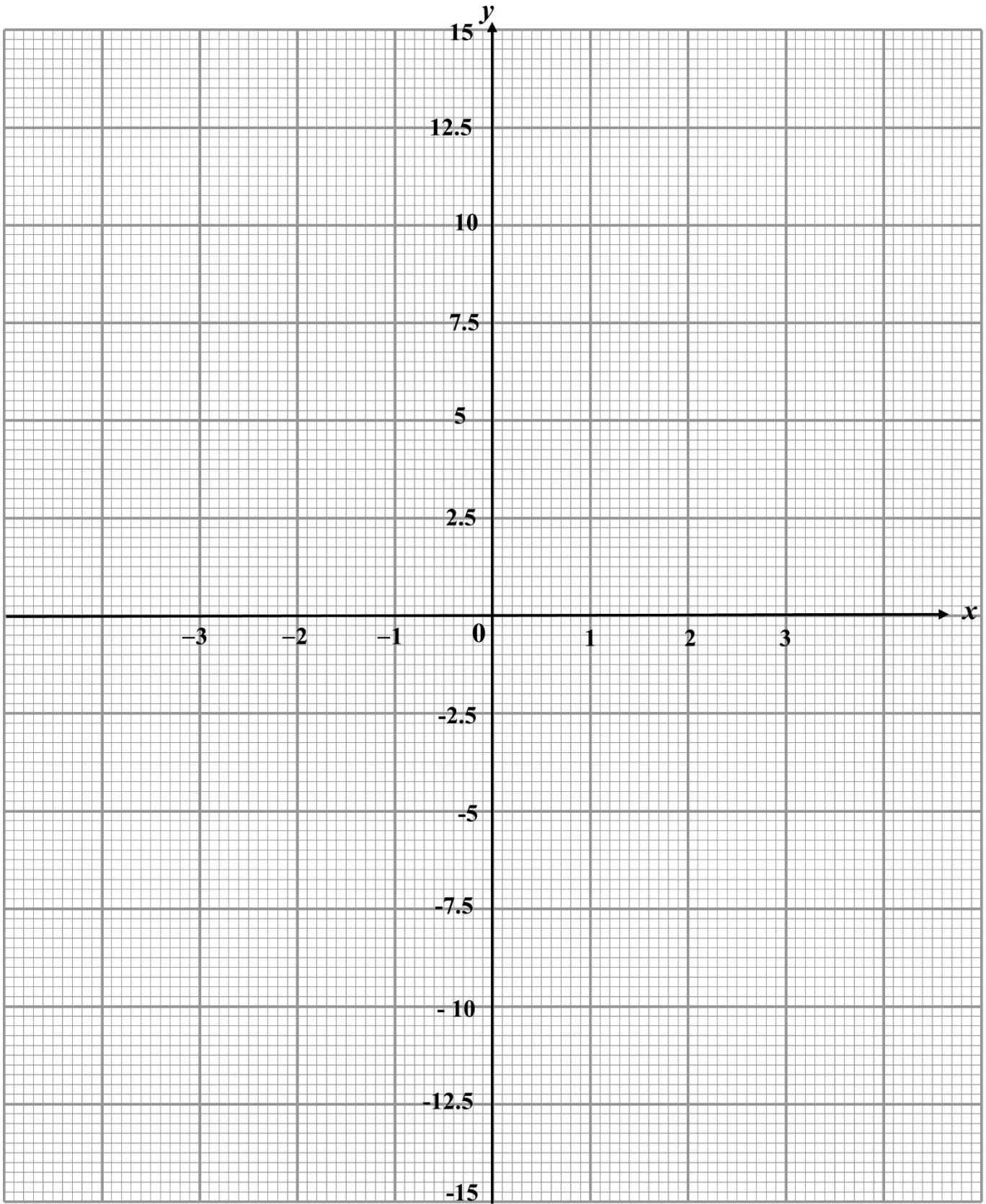

- 10 The tables below show the start-up kits for two food delivery companies, Get Food and Food Pack.

Get Food	Includes	Cost
Motorcycle/Car/Bicycle Basic Starter Pack	1 x Backpack 1 x Halal Bag 2 x Long Sleeve T-Shirt	\$72
Motorcycle/Car/Bicycle Upsized Pack	1 x Basic Starter Pack 1 x Sling Bag	\$105
Walker Starter Pack	1 x Sling Bag 1 x Halal Bag 2 x Long Sleeve T-Shirt	\$60

Food Pack	Includes	Cost
Bicycles Starter Pack	Reflective jacket Long sleeve base Phone mount (optional) Helmet (optional) Insulated backpack	\$50
Scooters / Motorcycles Starter Pack	Reflective jacket Long sleeve base Phone mount (optional) Small thermal bag Insulated backpack	\$50
Walkers Starter Pack	Reflective jacket Long sleeve base Walker's lanyard Insulated backpack	\$50

The table below shows the payments and benefits of the two food delivery companies.

	Get Food	Food Pack
Non-peak hours	\$5.50 per delivery	\$6 per delivery
Peak hours	\$6.50 per delivery	\$7 per delivery
Late fees	No late fees, but rider will not be given priority for the job after 5 late deliveries	Deduct \$1.50 per delivery
Other benefits	Bonus of \$10 will be given after every 13 deliveries. Bicycle rental at special rates: 7-Day Pass : \$6.90 30-Day Pass : \$19.90	Free bicycle rental

- (a) (i) Ben wants to work as a food delivery rider (bicycle) during the one-month school holiday. He is choosing between two companies – Get Food and Food Pack.

Ben wants to work 5 days a week, during non-peak hours. He can make an average of 6 deliveries a day during non-peak hours. Ben does not own a bicycle. Assuming that he makes three late deliveries in one month, how much does he earn in that month if he works with Get Food and Food Pack?

[6]

- (ii) Besides making more deliveries, what is one other way Ben can increase his earnings?

Answer (a) (ii) _____

[1]

- (b) (i) Karl wants to work as a food delivery walker with Get Food during peak hours. He aims to earn at least \$200.

Fill in the table below to show how much Get Food pays a food delivery walker during peak hours.

	Minimum payment	Maximum payment
1 to 12 deliveries	\$6.50	\$78
13 to 25 deliveries	\$94.50	\$ _____
26 to 38 deliveries	\$ _____	\$267

[2]

- (ii) What is the minimum number of deliveries Karl must make in order to earn at least \$200?

Answer (b) (ii) _____

[2]

End of Paper



BENDEMEER SECONDARY SCHOOL
2024 PRELIMINARY EXAMINATION
SECONDARY 4 EXPRESS / 5 NORMAL (ACADEMIC)

CANDIDATE
NAME

CLASS

INDEX
NUMBER

MATHEMATICS

Paper 2

4052/02

21 August 2024

2 hours 15 minutes

Candidates answer on the Question Paper.
No additional materials are required.

READ THESE INSTRUCTIONS FIRST

Write your name, class and register number on all the work you hand in.
Write in dark blue or black pen.
You may use an HB pencil for any diagrams or graphs.
Do not use staples, paper clips, highlighters, glue or correction fluid.
DO NOT WRITE ON ANY BARCODES.

**MARKING
SCHEME**

Answer **all** the questions.

The number of marks is given in brackets [] at the end of each question or part question.

If working is needed for any question, it must be shown with the answer.

Omission of essential working will result in loss of marks.

The total number of marks for this paper is 90.

The use of an approved scientific calculator is expected, where appropriate.

If the degree of accuracy is not specified in the question, and if the answer is not exact, give the answer to three significant figures. Give answers in degrees to one decimal place.

For π , use either your calculator value or 3.142.

FOR EXAMINER'S USE
90

MATHEMATICAL FORMULAE*Compound Interest*

$$\text{Total amount} = P \left(1 + \frac{r}{100} \right)^n$$

Mensuration

$$\text{Curved surface area of cone} = \pi r l$$

$$\text{Surface area of a sphere} = 4 \pi r^2$$

$$\text{Volume of a cone} = \frac{1}{3} \pi r^2 h$$

$$\text{Volume of sphere} = \frac{4}{3} \pi r^3$$

$$\text{Area of triangle ABC} = \frac{1}{2} ab \sin C$$

$$\text{Arc length} = r\theta, \text{ where } \theta \text{ is in radians}$$

$$\text{Sector area} = \frac{1}{2} r^2 \theta, \text{ where } \theta \text{ is in radians}$$

Trigonometry

$$\frac{a}{\sin A} = \frac{b}{\sin B} = \frac{c}{\sin C}$$

$$a^2 = b^2 + c^2 - 2bc \cos A$$

Statistics

$$\text{Mean} = \frac{\sum fx}{\sum f}$$

$$\text{Standard Deviation} = \sqrt{\frac{\sum fx^2}{\sum f} - \left(\frac{\sum fx}{\sum f} \right)^2}$$

1	(a)	<p>Simplify $\left(\frac{3a^{-\frac{3}{2}}b^2}{4^{\frac{1}{2}}b^3}\right)^{-2}$ and leave your answer in positive index notation.</p> $= \left(\frac{4^{\frac{1}{2}}b^3}{3a^{-\frac{3}{2}}b^2}\right)^2 \dots\dots\dots \text{M1}$ $= \frac{4b^6}{9a^{-3}b^4} \dots\dots\dots \text{M1}$ $= \frac{4a^3b^2}{9} \dots\dots\dots \text{A1}$ <p style="text-align: right;"><i>Answer (a)</i> _____</p>	[3]
	(b)	<p>Simplify $\frac{(a-5b)^2}{a^2-25b^2} \div \frac{a-5b}{5b}$.</p> $= \frac{(a-5b)^2}{(a-5b)(a+5b)} \times \frac{5b}{a-5b} \dots\dots\dots \text{M1 for } (a-5b)(a+5b)$ $= \frac{5b}{a+5b} \dots\dots\dots \text{A1}$ <p style="text-align: right;"><i>Answer (b)</i> _____</p>	[2]

- 2 The diagram below shows a school Tchoukball court of dimension 27m by 16m. On each end is a semicircle of radius 3m. The shaded part is to be painted yellow.

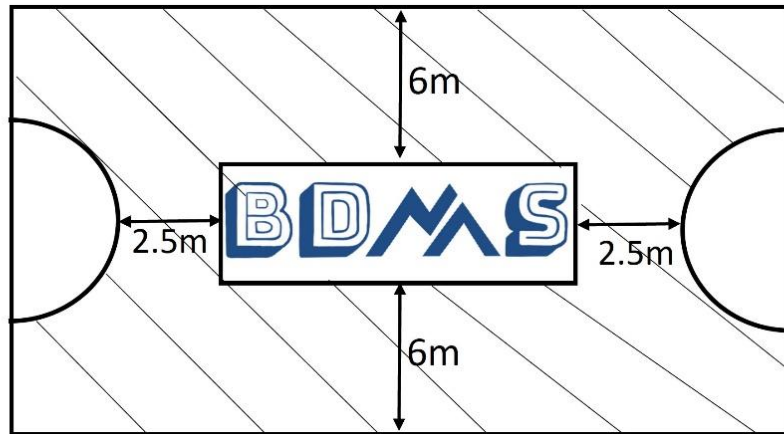

- (a) Find the area of the court that is painted yellow.

Area that is painted yellow

$$= (27 \times 16) - (\pi \times 3^2) - (16 \times 4) \dots\dots\dots \text{M1}$$

$$= 339.726$$

$$= 340 \text{ m}^2 \text{ (3sf)} \dots\dots\dots \text{A1}$$

Answer (a) _____m² [2]

- (b) 3 workers can paint the court in 5 days. After painting the first day, the workers had to stop on the second and third day because it was raining. Teachers, Mr Chin and Mr Lee, decided to help with the painting on the fourth and fifth day. Assuming the 3 workers and 2 teachers paint at the same rate, can they finish painting the shaded area on the fifth day? Show your working clearly.

[3]

Man-days needed to paint the court

$$= 5 \times 3$$

$$= 15 \dots\dots\dots \text{M1}$$

Man-days needed after the first day

$$= 15 - (3 \times 1)$$

$$= 12$$

Number of people needed for the fourth and fifth days

$$= 12 \div 2$$

$$= 6 \dots\dots\dots \text{M1}$$

Number of workers and teachers painting on the fourth and fifth days

$$= 5$$

} A1

Therefore, they cannot finish painting on the fifth day.

3

- (a) In the diagram, $\angle ABD = \angle CBD$ and $\angle BAD = \angle BCD$.
Prove that $\triangle ABD$ and $\triangle CBD$ are congruent.

[3]

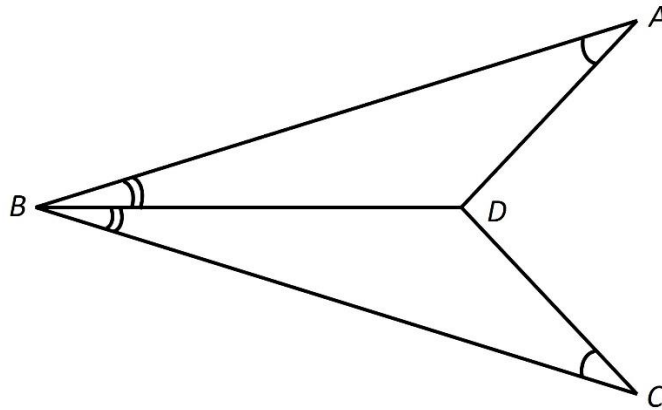

In $\triangle ABD$ and $\triangle CBD$,

BD is common

$\angle ABD = \angle CBD$ (given)

$\angle BAD = \angle BCD$ (given)

} B2 for 3 correct statements

} B1 for 2 correct statements

Therefore, $\triangle ABD$ and $\triangle CBD$ are congruent (AAS) B1

- (b) In the diagram below, O is the centre of the circle and BDG is a straight line. PQ is a tangent to the circles at A and H respectively. $\angle ABD = 27^\circ$ and $\angle DEF = 153^\circ$.

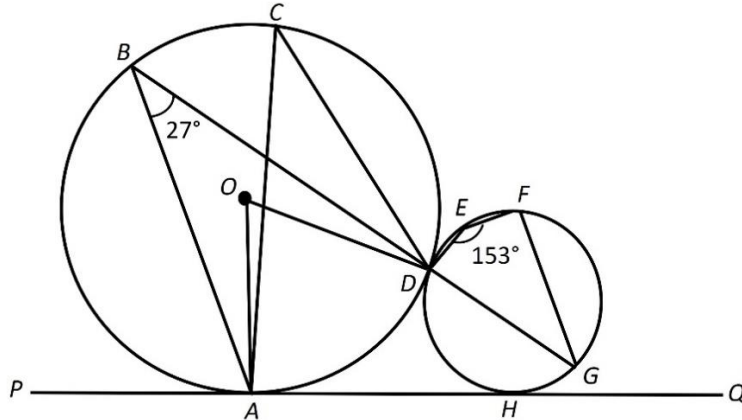

Stating the angle properties of circles clearly, find

- (i) $\angle ACD$

= 27° (Angle in the same segment) B1

Answer (i) _____⁰ [1]

- (ii) $\angle DAH$

$\angle OAH = 90^\circ$ (radius perpendicular to tangent)
 $\angle AOD = 54^\circ$ (Angle at centre = $2x$ angle at circumference) } M1 for either property

$$\begin{aligned} \angle OAD &= \frac{180 - 54}{2} \\ &= 63^\circ \end{aligned}$$

$$\begin{aligned} \angle DAH &= 90 - 63 \\ &= 27^\circ \text{ A1} \end{aligned}$$

Answer (ii) _____⁰ [2]

- (iii) Is BA parallel to FG ? Justify your answer clearly with working. [3]

$$\begin{aligned} \angle DGF &= 180 - 153 \text{ (Angles in opposite segments)} \\ &= 27^\circ \text{ M1} \end{aligned}$$

Since $\angle ABD = \angle DGF = 27^\circ$, M1
 By the converse of alternate angles, BA is parallel to FG A1

Note: Minus 1 mark from Q3(b) when angle properties of circles are not given / written wrongly.

4 Starkids Centre is organising a talent competition for children. Children can choose to compete in 3 categories – singing, dancing and acting.

Matrix **E** shows the number of boys and girls in each category for the age group 5 to 8 years old.

$$\mathbf{E} = \begin{matrix} & \begin{matrix} \text{Boys} & \text{Girls} \end{matrix} \\ \begin{pmatrix} 5 & 8 \\ 7 & 4 \\ 6 & 7 \end{pmatrix} & \begin{matrix} \text{Singing} \\ \text{Dancing} \\ \text{Acting} \end{matrix} \end{matrix}$$

Matrix **F** shows the number of boys and girls in each category for the age group 9 to 12 years old.

$$\mathbf{F} = \begin{matrix} & \begin{matrix} \text{Boys} & \text{Girls} \end{matrix} \\ \begin{pmatrix} 12 & 9 \\ 8 & 10 \\ 15 & 11 \end{pmatrix} & \begin{matrix} \text{Singing} \\ \text{Dancing} \\ \text{Acting} \end{matrix} \end{matrix}$$

(a) Evaluate the matrix $\mathbf{T} = \mathbf{E} + \mathbf{F}$.

$$\begin{aligned} \mathbf{T} &= \begin{pmatrix} 5 & 8 \\ 7 & 4 \\ 6 & 7 \end{pmatrix} + \begin{pmatrix} 12 & 9 \\ 8 & 10 \\ 15 & 11 \end{pmatrix} \\ &= \begin{pmatrix} 17 & 17 \\ 15 & 14 \\ 21 & 18 \end{pmatrix} \dots\dots\dots \text{B1} \end{aligned}$$

Answer (a) $\mathbf{T} =$ _____

[1]

(b) Each child is charged a registration fee for the competition. The registration is \$30 for singing, \$25 for dancing and \$22 for acting. Represent the fees in a 1 x 3 matrix **C**.

$$\mathbf{C} = (30 \quad 25 \quad 22) \dots\dots\dots \text{B1}$$

Answer (b) $\mathbf{C} =$ _____

[1]

	<p>(c) Evaluate the matrix $\mathbf{M} = \mathbf{CT}$ and state what the elements in matrix \mathbf{M} represent.</p> $\mathbf{M} = (30 \quad 25 \quad 22) \begin{pmatrix} 17 & 17 \\ 15 & 14 \\ 21 & 18 \end{pmatrix}$ $= (1347 \quad 1256) \dots\dots\dots \text{B1, B1}$ <p>\mathbf{M} represents the registration fees collected from <u>boys and girls respectively</u> B1</p> <p style="text-align: right;"><i>Answer (c) M =</i> _____</p> <hr/> <hr/>	<p>[2]</p> <p>[1]</p>
	<p>(d) Using matrix multiplication, calculate the total amount of registration fees collected for this competition.</p> $(1347 \quad 1256) \times \begin{pmatrix} 1 \\ 1 \end{pmatrix} \dots\dots\dots \text{M1}$ $= (2603) \dots\dots\dots \text{A1}$ <p style="text-align: right;"><i>Answer (d) \$</i> _____</p>	<p>[2]</p>
	<p>(e) Starkids Centre decides to organise a similar competition for teenagers aged 13 to 18 years old. As compared to the competition for children, the registration fees for teenagers is increased by 10% for singing, 20% for dancing and 15% for acting.</p> <p>Using matrix multiplication, calculate the registration fees for teenagers for each category. Give your answer in matrix form.</p> $(30 \quad 25 \quad 22) \times \begin{pmatrix} 1.1 & 0 & 0 \\ 0 & 1.2 & 0 \\ 0 & 0 & 1.15 \end{pmatrix} \dots\dots\dots \text{M1}$ $= (33 \quad 30 \quad 25.3) \dots\dots\dots \text{A1}$ <p style="text-align: right;"><i>Answer (e)</i> _____</p>	<p>[2]</p>

5 In the diagram, M is the midpoint of OA .
 $\vec{OA} = \mathbf{a}$, $\vec{OB} = \mathbf{b}$, $\vec{AP} = -\frac{1}{2}\mathbf{a} + \frac{5}{6}\mathbf{b}$ and $BN : NA = 3 : 5$.

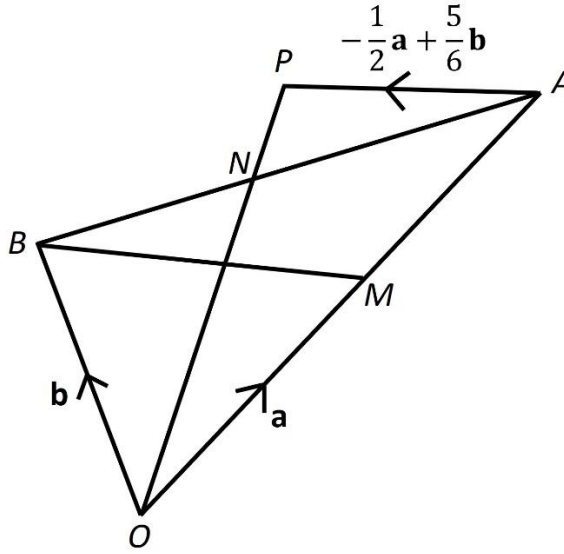

(a) Express, as simply as possible, in terms of \mathbf{a} and/or \mathbf{b} ,

(i) \vec{BN}

(ii) \vec{BM}

(iii) \vec{NM}

$$\begin{aligned} \vec{BN} &= \frac{3}{8}\vec{BA} \\ &= \frac{3}{8}\mathbf{a} - \frac{3}{8}\mathbf{b} \dots\dots\dots \text{B1} \end{aligned}$$

$$\begin{aligned} \vec{BM} &= \frac{1}{2}\mathbf{a} - \mathbf{b} \dots\dots\dots \text{B1} \end{aligned}$$

$$\begin{aligned} \vec{NM} &= \vec{NB} + \vec{BM} \\ &= -\frac{3}{8}\mathbf{a} + \frac{3}{8}\mathbf{b} + \frac{1}{2}\mathbf{a} - \mathbf{b} \dots\dots\dots \text{M1} \\ &= \frac{1}{8}\mathbf{a} - \frac{5}{8}\mathbf{b} \dots\dots\dots \text{A1} \end{aligned}$$

Answer (a) (i) _____ [1]

(ii) _____ [1]

(iii) _____ [2]

	<p>(b) Find $\frac{\text{Area of } \triangle OBM}{\text{Area of } \triangle OBA}$</p> <p>$= \frac{1}{2}$ B1</p> <p style="text-align: right;"><i>Answer (b)</i> _____</p>	[1]
	<p>(c) If $ONAC$ is a parallelogram, find \vec{CA}</p> <p>\vec{CA}</p> <p>$= \vec{ON}$</p> <p>$= \vec{OB} + \vec{BN}$</p> <p>$= \mathbf{b} + \frac{3}{8}\mathbf{a} - \frac{3}{8}\mathbf{b}$ M1</p> <p>$= \frac{3}{8}\mathbf{a} + \frac{5}{8}\mathbf{b}$ A1</p> <p style="text-align: right;"><i>Answer (c)</i> _____</p>	[2]
	<p>(d) Given that $\frac{OP}{ON} = k$, find the value of k.</p> <p>\vec{OP}</p> <p>$= \vec{OA} + \vec{AP}$</p> <p>$= \mathbf{a} - \frac{1}{2}\mathbf{a} + \frac{5}{6}\mathbf{b}$</p> <p>$= \frac{1}{2}\mathbf{a} + \frac{5}{6}\mathbf{b}$ M1</p> <p>$= \frac{1}{6}(3\mathbf{a} + 5\mathbf{b})$</p> <p>$\vec{ON} = \frac{3}{8}\mathbf{a} + \frac{5}{8}\mathbf{b}$</p> <p>$\vec{ON} = \frac{1}{8}(3\mathbf{a} + 5\mathbf{b})$</p> <p>Therefore,</p> <p>$\frac{OP}{ON} = \frac{\frac{1}{6}(3\mathbf{a}+5\mathbf{b})}{\frac{1}{8}(3\mathbf{a}+5\mathbf{b})}$ M1</p> <p>$\frac{OP}{ON} = \frac{4}{3}$</p> <p>$k = \frac{4}{3}$ A1</p> <p style="text-align: right;"><i>Answer (d)</i> $k =$ _____</p>	[3]

<p>6</p>	<p>The diagram represents the cross-section of a tunnel where AC is on level ground and B is the highest point of the tunnel. The height of the tunnel is 6m and $AC = 5m$.</p>	
	<p>(a) Show that radius of the tunnel, $r = 3.5m$, corrected to 2 significant numbers.</p> <div style="display: flex; justify-content: space-between; align-items: center;"> <div data-bbox="293 383 772 741" style="text-align: center;"> </div> <div data-bbox="938 371 1390 629" style="text-align: left;"> $(6 - r)^2 + 2.5^2 = r^2 \dots\dots\dots \text{M1}$ $36 - 12r + r^2 + 6.25 = r^2$ $12r = 42.25$ $r = 3.5 \text{ cm (shown)} \dots\dots\dots \text{A1}$ </div> </div>	<p>[2]</p>
	<p>(b) During a flood, water in the tunnel rose up to EF, 0.3m above ground level.</p> <div style="text-align: center; margin: 20px 0;"> </div>	
	<p>(i) Find $\angle EOF$ in radian.</p> $\frac{1}{2} \angle EOF = \cos^{-1} \left(\frac{6-3.5-0.3}{3.5} \right) \dots\dots\dots \text{M1}$ $\frac{1}{2} \angle EOF = \cos^{-1} \left(\frac{2.2}{3.5} \right)$ $\angle EOF = 1.78216 \text{ rad}$ $\angle EOF = 1.78 \text{ rad (3sf)} \dots\dots\dots \text{A1}$	<p>Answer (b) (i) _____ radian [2]</p>

	<p>(ii) Find the length of the major arc EBF.</p> <p>$3.5(2\pi - 1.78216)$ M1</p> <p>$= 15.8$ m A1</p> <p style="text-align: right;"><i>Answer (ii)</i> _____ m</p>	[2]
	<p>(iii) Find the cross-section area of the tunnel which is dry.</p> <p>$\frac{1}{2}(3.5^2)(2\pi - 1.78216) + \frac{1}{2}(3.5^2) \sin 1.78216$ M1, M1</p> <p>$= 33.55747$</p> <p>$= 33.6$ m² (3sf) A1</p> <p style="text-align: right;"><i>Answer (iii)</i> _____ m²</p>	[3]
	<p>(iv) Given that the length of the tunnel is 1.4km, find the volume of the tunnel which is dry.</p> <p>33.55747×1400 M1</p> <p>$= 47\,000$ m³ (3sf) A1</p> <p style="text-align: right;"><i>Answer (iv)</i> _____ m³</p>	[2]

7 The diagram shows a park $ABCD$ on horizontal ground. DB represents a pebbled path. $AB = 180\text{m}$, $BC = 220\text{m}$, $CD = 310\text{m}$ and $DA = 150\text{m}$. $\angle DAB = 135^\circ$ and $\angle DBC = 76^\circ$.

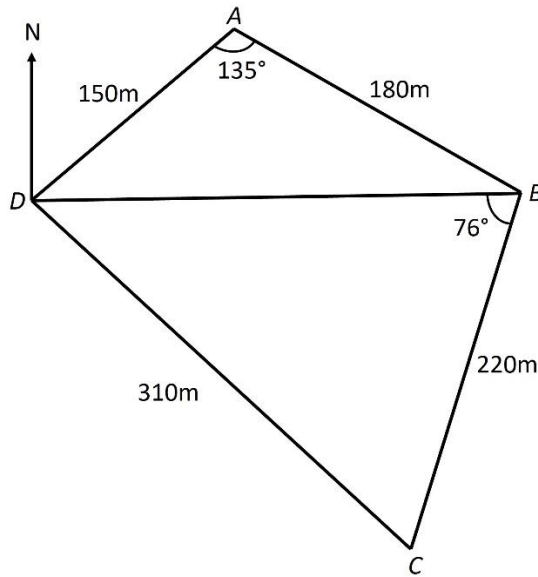

(a) Find the distance of the pebbled path DB .

$$DB^2 = 150^2 + 180^2 - 2(150)(180) \cos 135^\circ \dots\dots\dots \text{M1}$$

$$DB = 305.0963$$

$$DB = 305 \text{ m (3sf)} \dots\dots\dots \text{A1}$$

Answer (a) _____ m [2]

(b) Find $\angle BDC$.

$$\frac{\sin \angle BDC}{220} = \frac{\sin 76^\circ}{310} \dots\dots\dots \text{M1}$$

$$\angle BDC = 43.5191^\circ$$

$$\angle BDC = 43.5^\circ \text{ (1dp)} \dots\dots\dots \text{A1}$$

Answer (b) _____⁰ [2]

	<p>(c) Find the shortest distance from A to DB.</p> $\frac{1}{2} \times 150 \times 180 \times \sin 135^\circ = \frac{1}{2} \times 305.0963 \times d \dots\dots\dots \text{M1, M1}$ $d = 62.5766$ $d = 62.6 \text{ m (3sf) } \dots\dots\dots \text{A1 (ft)}$ <p style="text-align: right;"><i>Answer (c)</i> _____ m</p>	[3]
	<p>(d) A lamp post, 12m, is erected vertically at A. Find the greatest angle of elevation of the top of the lamp post from DB.</p> $\tan^{-1}\left(\frac{12}{62.5766}\right) \dots\dots\dots \text{M1}$ $= 10.9^\circ \text{ (1dp) } \dots\dots\dots \text{A1 (ft)}$ <p style="text-align: right;"><i>Answer (d)</i> _____ ^o</p>	[2]
	<p>(e) Given that B is due east of D, find the bearing of D from C.</p> $360^\circ - (180^\circ - 90^\circ - 43.5191^\circ) \dots\dots\dots \text{M1}$ $= 313.5^\circ \text{ (1dp) } \dots\dots\dots \text{A1 (ft)}$ <p style="text-align: right;"><i>Answer (e)</i> _____</p>	[2]

8	<p>In July, the price of durians was \$$x$ per kg. In August, the price of durians dropped by \$4.50 per kg. Don could buy 2.8 kg more durians in August than in July with \$200.</p>	
	<p>(a) Write down an expression, in terms of x, to show the mass of durians that can be bought for \$200 in July.</p> <p>$\frac{200}{x}$ B1</p> <p style="text-align: right;"><i>Answer (a)</i> _____ kg</p>	[1]
	<p>(b) Write down an expression, in terms of x, to show the mass of durians that can be bought for \$200 in August.</p> <p>$\frac{200}{x-4.5}$ B1</p> <p style="text-align: right;"><i>Answer (b)</i> _____ kg</p>	[1]
	<p>(c) Form an equation in terms of x and show that it reduces to $14x^2 - 63x - 4500 = 0$.</p> <p>$\frac{200}{x-4.5} - \frac{200}{x} = 2.8$ M1</p> <p>$200(x) - 200(x - 4.5) = 2.8x(x - 4.5)$</p> <p>$900 = 2.8x^2 - 12.6x$ M1</p> <p>$28x^2 - 126x - 9000 = 0$</p> <p>$14x^2 - 63x - 4500 = 0$ (shown) A1</p>	[3]

	<p>(d) Solve the equation $14x^2 - 63x - 4500 = 0$. Give your answers corrected to 2 decimal places.</p> $x = \frac{63 \pm \sqrt{(-63)^2 - 4(14)(-4500)}}{2(14)} \dots\dots\dots \text{M1}$ $x = \frac{63 \pm \sqrt{255969}}{2(14)}$ $x = -15.82 \text{ or } 20.32 \dots\dots\dots \text{A1, A1}$ <p style="text-align: right;"><i>Answer (d) x = _____ or _____</i></p>	[3]
	<p>(e) Find the price of the durians per kg in August.</p> $20.3191 - 4.50 = \$15.82 \text{ (2dp)} \dots\dots\dots \text{B1 (ft)}$ <p style="text-align: right;"><i>Answer (e) \$ _____</i></p>	[1]
	<p>(f) Find the percentage drop in price in August compared to July.</p> $\frac{4.50}{20.3191} \times 100\%$ $= 22.1\% \text{ (3sf)} \dots\dots\dots \text{B1 (ft)}$ <p style="text-align: right;"><i>Answer (f) _____%</i></p>	[1]

<p>9</p>	<p>The variables x and y are connected by the equation $y = \frac{1}{2}x^3 + \frac{1}{5x}$.</p> <p>Some corresponding values of x and y, correct to 1 decimal place, are given in the table below.</p> <table border="1" data-bbox="188 327 1431 409"> <tr> <td>x</td> <td>-3</td> <td>-2</td> <td>-1</td> <td>-0.5</td> <td>-0.1</td> <td>0.1</td> <td>0.5</td> <td>1</td> <td>2</td> <td>3</td> </tr> <tr> <td>y</td> <td>-13.6</td> <td>p</td> <td>-0.7</td> <td>-0.5</td> <td>-2.0</td> <td>2.0</td> <td>0.5</td> <td>0.7</td> <td>4.1</td> <td>13.6</td> </tr> </table>	x	-3	-2	-1	-0.5	-0.1	0.1	0.5	1	2	3	y	-13.6	p	-0.7	-0.5	-2.0	2.0	0.5	0.7	4.1	13.6	
x	-3	-2	-1	-0.5	-0.1	0.1	0.5	1	2	3														
y	-13.6	p	-0.7	-0.5	-2.0	2.0	0.5	0.7	4.1	13.6														
	<p>(a) Calculate the value of p.</p> <p>$p = -4.1$ B1</p> <p style="text-align: right;"><i>Answer (a)</i> $p =$ _____</p>	[1]																						
	<p>(b) On the axes given on Page 19, draw the graph of $y = \frac{1}{2}x^3 + \frac{1}{5x}$.</p> <p>Correct points B1 Smooth curve B1</p>	[2]																						
	<p>(c) Using your graph, find the y when $x = -2.4$.</p> <p>$y = -7 \pm 0.25$ B1</p> <p style="text-align: right;"><i>Answer (c)</i> $y =$ _____</p>	[1]																						
	<p>(d) By drawing a tangent, find the gradient of the curve at $x = 2$.</p> <p>Tangent M1</p> <p>Gradient = 6 ± 2 A1</p> <p style="text-align: right;"><i>Answer (d)</i> _____</p>	[2]																						
	<p>(e) By drawing a suitable straight line, find the solution of $\frac{1}{2}x^3 + \frac{1}{5x} + 2.5x + 5 = 0$.</p> <p>Line: $y = -2.5x - 5$ M1</p> <p>$x = -1.4 \pm 0.1$ A1</p> <p style="text-align: right;"><i>Answer (e)</i> $x =$ _____</p>	[2]																						
	<p>(f) Explain why the curve does not touch the y-axis.</p> <p>At y-axis, $x = 0$, the curve is undefined..... B1</p> <p><i>Answer (f)</i> _____</p> <p>_____</p>	[1]																						

Answer (9a)

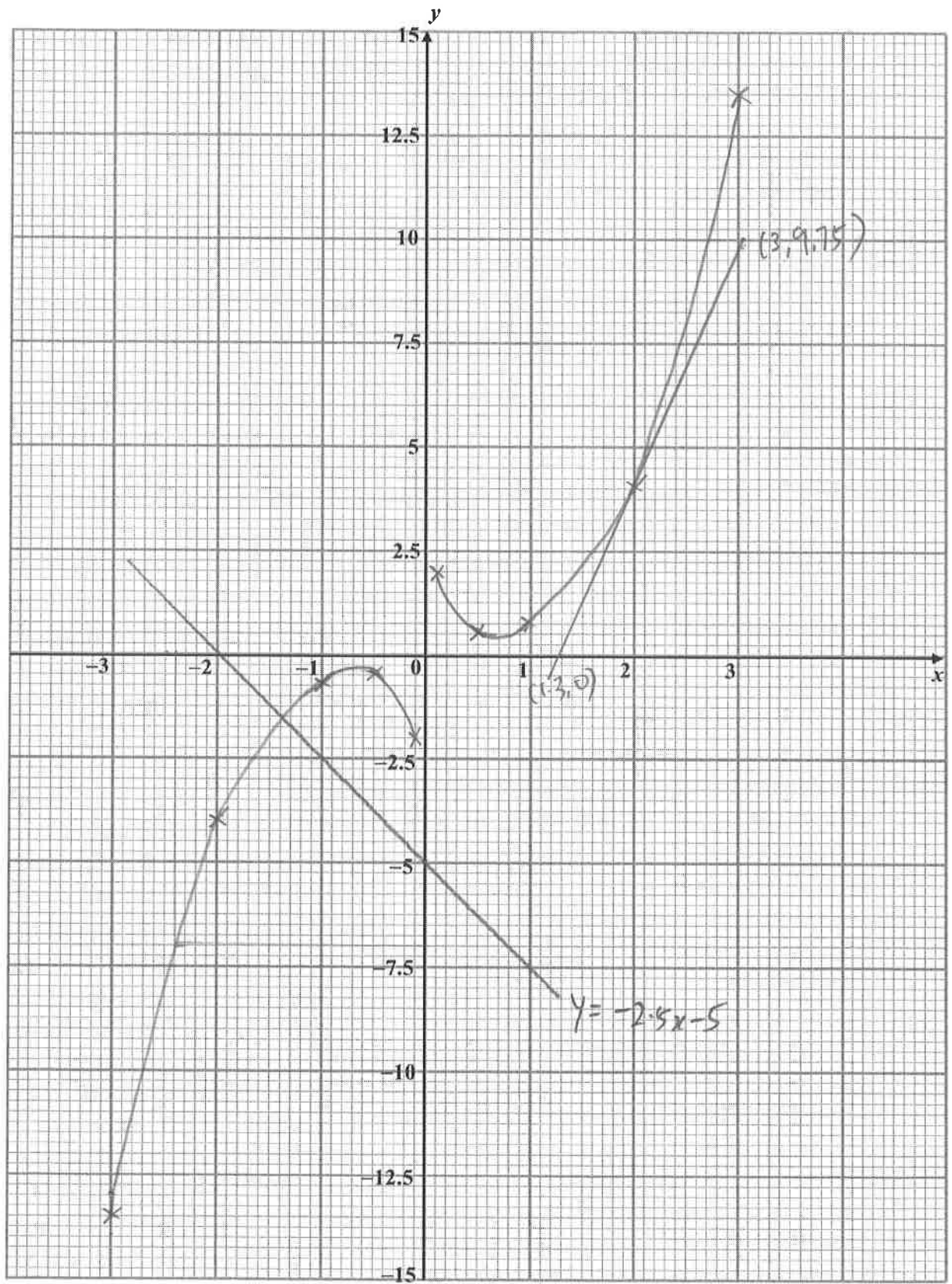

10 The tables below show the start-up kits for two food delivery companies, Get Food and Food Pack.

Get Food	Includes	Cost
Motorcycle/Car/Bicycle Basic Starter Pack	1 x Backpack 1 x Halal Bag 2 x Long Sleeve T-Shirt	\$72
Motorcycle/Car/Bicycle Upsized Pack	1 x Basic Starter Pack 1 x Sling Bag	\$105
Walker Starter Pack	1 x Sling Bag 1 x Halal Bag 2 x Long Sleeve T-Shirt	\$60

Food Pack	Includes	Cost
Bicycles Starter Pack	Reflective jacket Long sleeve base Phone mount (optional) Helmet (optional) Insulated backpack	\$50
Scooters / Motorcycles Starter Pack	Reflective jacket Long sleeve base Phone mount (optional) Small thermal bag Insulated backpack	\$50
Walkers Starter Pack	Reflective jacket Long sleeve base Walker's lanyard Insulated backpack	\$50

The table below shows the payments and benefits of the two food delivery companies.

	Get Food	Food Pack
Non-peak hours	\$5.50 per delivery	\$6 per delivery
Peak hours	\$6.50 per delivery	\$7 per delivery
Late fees	No late fees, but rider will not be given priority for the job after 5 late deliveries	Deduct \$1.50 per delivery
Other benefits	Bonus of \$10 will be given after every 13 deliveries. Bicycle rental at special rates: 7-Day Pass : \$6.90 30-Day Pass : \$19.90	Free bicycle rental

	<p>(a) (i)</p>	<p>Ben wants to work as a food delivery rider (Bicycle) during the one-month school holiday. He is choosing between two companies – Get Food and Food Pack.</p> <p>Ben wants to work 5 days a week, during non-peak hours. He can make an average of 6 deliveries a day during non-peak hours. Ben does not own a bicycle. Assuming that he makes three late deliveries in one month, how much does he earn in that month if he works with Get Food and Food Pack?</p> <p><u>Get Food</u></p> <p>Revenue $= (5 \times 6 \times 4 \times \\$5.50) + (9 \times \\$10)$ $= \\$750$ M1</p> <p>Earnings $= \\$750 - \\$72 - \\$19.90$M1 $= \\$658.10$ A1</p> <p><u>Food Pack</u></p> <p>Revenue $= (5 \times 6 \times 4 \times \\$6)$ $= \\$720$ M1</p> <p>Earnings $= \\$720 - \\$50 - (3 \times \\$1.50)$M1 $= \\$665.50$ A1</p>	<p>[6]</p>
--	----------------	---	------------

	(ii)	<p>Besides making more deliveries, what is one other way Ben can increase his earnings?</p> <p>work peak hours, don't be late for deliveries, other appropriate answers B1</p> <p>Answer (a) (ii) _____</p>	[1]												
	(b) (i)	<p>Karl wants to work as a food delivery walker with Get Food during peak hours. He aims to earn at least \$200.</p> <p>Fill in the table below to show how much Get Food pays a food delivery walker during peak hours.</p> <table border="1" data-bbox="336 779 1297 1155"> <thead> <tr> <th></th> <th>Minimum payment</th> <th>Maximum payment</th> </tr> </thead> <tbody> <tr> <td>1 to 12 deliveries</td> <td>\$6.50</td> <td>\$78</td> </tr> <tr> <td>13 to 25 deliveries</td> <td>\$94.50</td> <td>\$ <u>172.50</u> ... B1</td> </tr> <tr> <td>26 to 38 deliveries</td> <td>\$ <u>189</u> ... B1</td> <td>\$267</td> </tr> </tbody> </table>		Minimum payment	Maximum payment	1 to 12 deliveries	\$6.50	\$78	13 to 25 deliveries	\$94.50	\$ <u>172.50</u> ... B1	26 to 38 deliveries	\$ <u>189</u> ... B1	\$267	[2]
	Minimum payment	Maximum payment													
1 to 12 deliveries	\$6.50	\$78													
13 to 25 deliveries	\$94.50	\$ <u>172.50</u> ... B1													
26 to 38 deliveries	\$ <u>189</u> ... B1	\$267													
	(ii)	<p>What is the minimum number of deliveries Karl must make in order to earn at least \$200?</p> $\frac{200+60-20}{6.50} \dots\dots\dots M1$ $= 36.9$ <p>Therefore, he must make a minimum of 37 deliveries..... A1</p> <p>OR</p> $n \times 6.50 - 60 + 20 \geq 200 \dots\dots\dots M1$ $n \geq 36.9$ <p>Therefore, he must make a minimum of 37 deliveries..... A1</p> <p style="text-align: right;">Answer (b) (ii) _____</p>	[2]												

End of Paper