

*Visit*

**FREETESTPAPER.com**

*for more papers*



Website: [freetestpaper.com](http://www.freetestpaper.com)



[Facebook.com/freetestpaper](https://www.facebook.com/freetestpaper)



[Twitter.com/freetestpaper](https://www.twitter.com/freetestpaper)

Name: \_\_\_\_\_

--	--



# OUTRAM SECONDARY SCHOOL PRELIMINARY EXAMINATION 2024

**Subject** : **Mathematics**  
**Level (Stream)** : **Secondary Four Express  
& Five Normal Academic**  
**Paper** : **4052/01**  
**Date** : **21 August 2024**  
**Duration** : **2 hours 15 mins**  
**Marks** : **90**

### READ THESE INSTRUCTIONS FIRST

Write your name, class and index number on all the work you hand in.  
Write in dark blue or black pen.  
You may use an HB pencil for any diagrams or graphs.  
Do not use staples, paper clips, highlighters, glue or correction fluid.

Answer **all** questions on the Question Paper.  
If working is needed for any question it must be shown with the answer.  
Omission of essential working will result in loss of marks.  
The use of an approved scientific calculator is expected, where appropriate.  
If the degree of accuracy is not specified in the question, and if the answer is not exact, give the answer to three significant figures. Give answers in degrees to one decimal place.  
For  $\pi$ , use either your calculator value or 3.142, unless the question requires the answer in terms of  $\pi$ .

The number of marks is given in brackets [ ] at the end of each question or part question.

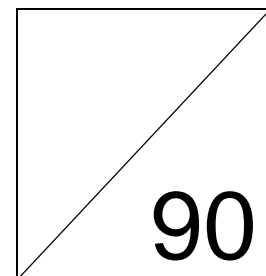

**Mathematical Formulae***Compound interest*

$$\text{Total amount} = P \left( 1 + \frac{r}{100} \right)^n$$

*Mensuration*

$$\text{Curved surface area of a cone} = \pi r l$$

$$\text{Surface area of a sphere} = 4\pi r^2$$

$$\text{Volume of a cone} = \frac{1}{3} \pi r^2 h$$

$$\text{Volume of a sphere} = \frac{4}{3} \pi r^3$$

$$\text{Area of triangle } ABC = \frac{1}{2} ab \sin C$$

$$\text{Arc length} = r\theta, \text{ where } \theta \text{ is in radians}$$

$$\text{Sector area} = \frac{1}{2} r^2 \theta, \text{ where } \theta \text{ is in radians}$$

*Trigonometry*

$$\frac{a}{\sin A} = \frac{b}{\sin B} = \frac{c}{\sin C}$$

$$a^2 = b^2 + c^2 - 2bc \cos A$$

*Statistics*

$$\text{Mean} = \frac{\sum fx}{\sum f}$$

$$\text{Standard deviation} = \sqrt{\frac{\sum fx^2}{\sum f} - \left( \frac{\sum fx}{\sum f} \right)^2}$$

Answer **all** the questions.

- 1** A running route is 42.2 km long and a runner took 4 hours 45 minutes to finish the route. Calculate the speed of the runner in metres per second.

*Answer* ..... m/s [2]

---

**2 (a)** Simplify  $\left(\frac{g^{12}}{256f^6}\right)^{-\frac{1}{4}}$ .

*Answer* ..... [2]

**(b)**  $5 \times 9^{k-1} = 15 \times 81$   
Find the value of  $k$ .

*Answer*  $k =$  ..... [3]

---

- 3 Given that  $\sin \theta = 0.8211$ , find the two possible values of  $\theta$ , where  $0^\circ \leq \theta \leq 180^\circ$ .

*Answer*  $\theta = \dots\dots\dots$  [2]

---

- 4 The number  $A = 2^7 \times 5^{11} \times 7^8$ .

- (a) Prove that  $A$  is divisible by 245.

*Answer*  $\dots\dots\dots$   
 $\dots\dots\dots$  [2]

- (b) The number  $A \times k$  is a perfect square.  
 Find the smallest possible integer value of  $k$ .

*Answer*  $k = \dots\dots\dots$  [1]

- (c) The number  $B = 2^5 \times 3^6 \times 7^3$ .  
 Find the highest common factor (HCF) and lowest common multiple (LCM) of  $A$  and  $B$  as a product of its prime factors.

*Answer* HCF =  $\dots\dots\dots$  [1]

LCM =  $\dots\dots\dots$  [1]

---

- 5** Zen invests \$42000 at a rate of 1.6% per annum compounded monthly.  
Calculate the value of the investment at the end of 3 years.

*Answer* \$ ..... [2]

---

- 6 (a)** Express  $x^2 + 6x + 10$  in the form of  $(x + h)^2 + k$ .

*Answer* ..... [2]

- (b)** Using your answer in **(a)**,

- (i)** write down the equation of the line of symmetry of the curve  $y = x^2 + 6x + 10$ .

*Answer* ..... [1]

- (ii)** Explain why the equation  $x^2 + 6x + 10 = 0$  does not have any solutions.

*Answer* .....

..... [1]

---

- 7 (a) Paul is 25% heavier than Mike. Mike is 25% lighter than Oscar.  
Find the ratio of the weight of Paul to that of Oscar.

*Answer* ..... [2]

- (b) Rachel bought 8 watches for \$900 each. She sold 4 watches at a profit of 80%,  
and 3 watches at a loss of 50%. She kept one watch for herself.

Calculate Rachel's net profit.

*Answer* \$ ..... [3]

---

- 8 A company produces light bulbs. The lifespan, in hours, of 240 light bulbs is tested. The cumulative frequency curve shows the distribution of lifespan of the light bulbs.

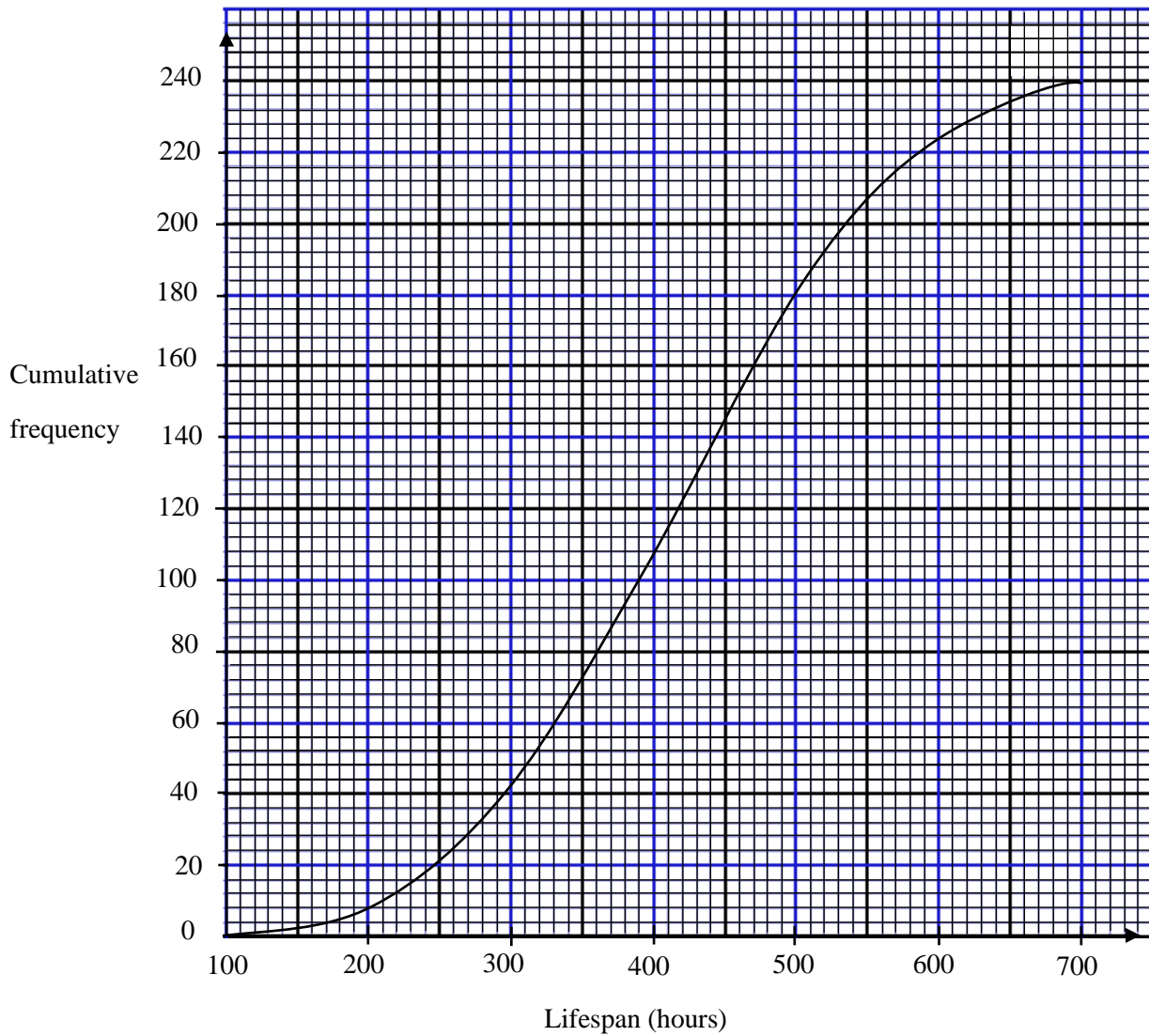

- (a) Use the diagram to estimate
- (i) the median lifespan of the light bulbs

*Answer* ..... h [1]

- (ii) the interquartile range of the lifespan of the light bulbs.

*Answer* ..... h [2]

- (b) Light bulbs with a lifespan of over  $x$  hours can be sold. Only 80 of the light bulbs tested meet this requirement.

Find the value of  $x$ .

*Answer*  $x =$  ..... [1]

---

- 9 The diagram, which is not drawn to scale, shows the three lines.

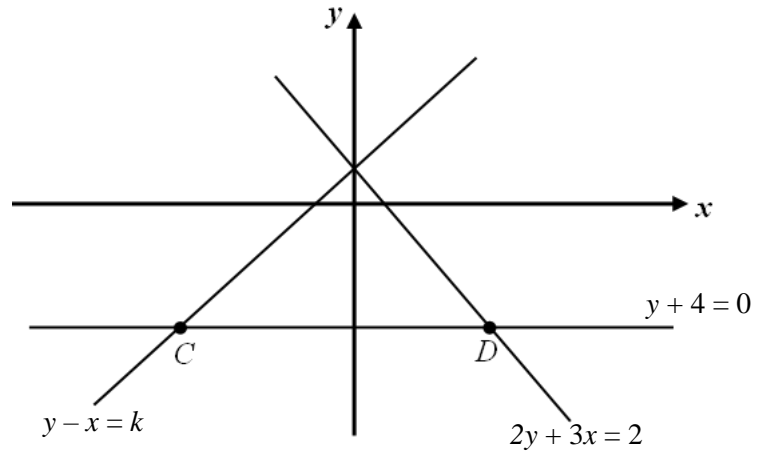

- (a) Show that  $k = 1$ .

*Answer:*

[1]

- (b) Find the coordinates of point  $D$ .

*Answer*  $D$  ( ..... , ..... ) [1]

---

**10** Write as a single fraction in its simplest form  $\frac{7y}{y+3} - \frac{y+9}{3-y}$ .

*Answer* ..... [2]

---

**11 (a)** Factorise completely.

**(i)**  $33x^2y + 11xy$ .

*Answer* ..... [1]

**(ii)**  $x^3 + x^2 - 9x - 9$ .

*Answer* ..... [3]

- (b) Expand and simplify  $(x + 3y)(4x - 3y)$ .

*Answer* ..... [1]

---

- 12** A bag contains blue, green and red marbles. There are 3 more green marbles than blue marbles. Half of the marbles in the bag are red.

Given that the probability of choosing a blue marble is  $\frac{6}{25}$ , find the number of green marbles in the bag.

*Answer* ..... [3]

---

**13** Show that  $x^2(3x-10) + 2(x^3 + 10x - 8) - 4$  is divisible by 5 for any integer  $x$ .

*Answer*

[3]

---

- 14** The diagram shows one interior angle of each of the three polygons,  $A$ ,  $B$  and  $C$ .  
The polygons fit together at the point  $O$ .  
The interior angle of polygon  $A$  is  $90^\circ$ .  
The interior angle of polygon  $B$  is  $130^\circ$ .

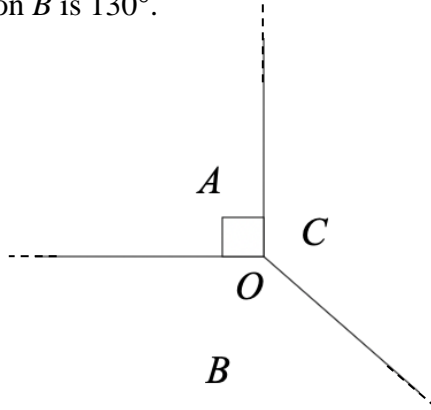

Explain why polygon  $C$  can be a regular polygon.

*Answer*

- 15 The graph shows the average performance score of two companies from year 2011 to 2015.

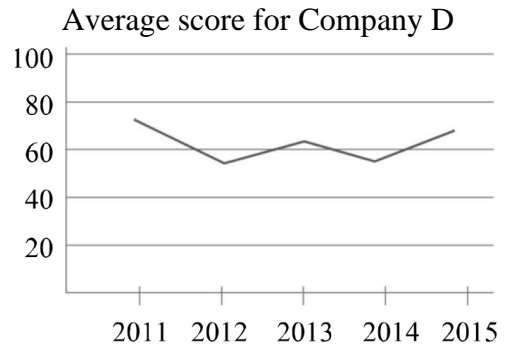
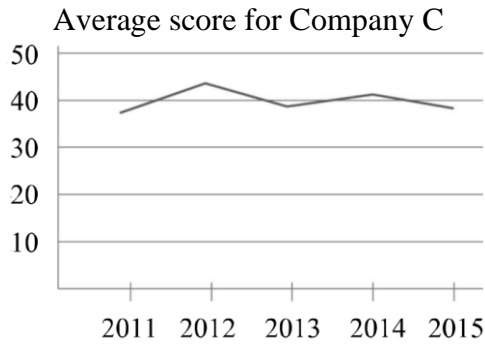

State one aspect of the graphs which may be misleading and explain how this may lead to a misinterpretation.

Answer .....

.....

..... [2]

- 16 (a) On the Venn diagram, shade the region that represents  $P' \cup Q$ .

Answer

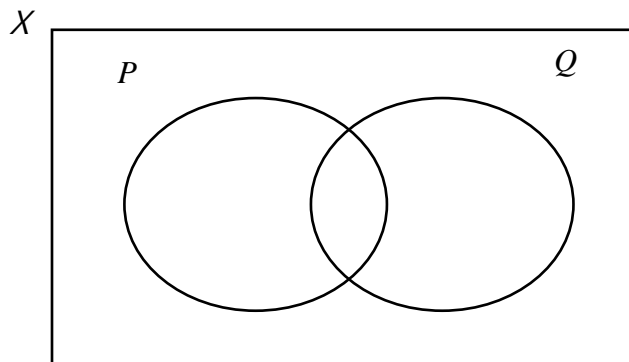

[1]

(b) It is given that

$$\mathcal{E} = \{x : x \text{ is an integer and } 10 \leq 3x + 5 < 40\},$$

$$A = \{x : x \text{ is divisible by 4}\} \text{ and}$$

$$B = \{x : x \text{ is a prime number}\}.$$

(i) List the elements in  $A$ .

*Answer* ..... [2]

(ii) Use one of the symbols below to complete each statement.

$$\in \notin \emptyset \subset \not\subset$$

$$A \dots\dots B$$

*Answer* ..... [1]

**17** Sketch the graph of  $y = -(2x + 3)(x - 8)$  on the axes below.

Indicate clearly the points where the graph crosses the axes and its turning point.

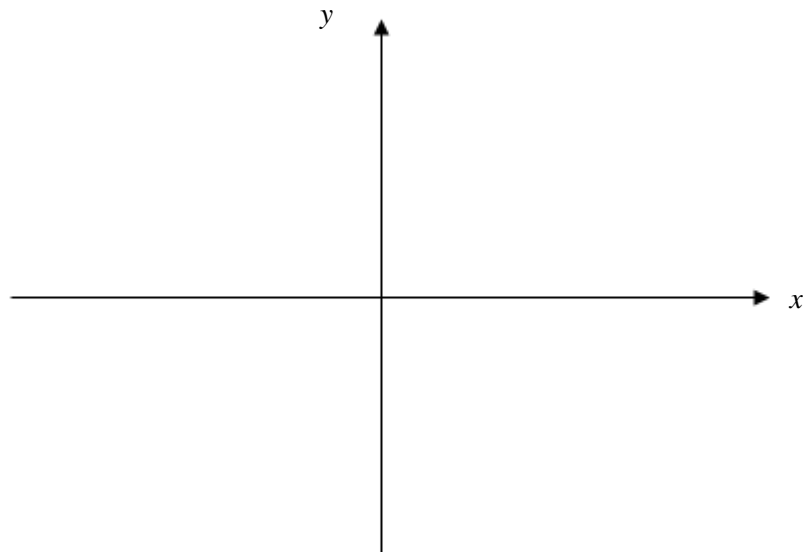

[3]

18 Simplify  $\frac{6x^2 - 7xy - 5y^2}{18x^2 - 50y^2}$ .

*Answer* ..... [3]

---

- 19  $y$  is proportional to the square root of  $x$ .  
If the value of  $x$  is increased by 300%, the value of  $y$  will be increased by  $r$  %.  
Find the value  $r$ .

*Answer* ..... [2]

---

- 20** A concert was held over a particular weekend. The matrix  $M$  shows the number of tickets sold on Saturday and Sunday respectively.

$$\mathbf{M} = \begin{matrix} & \begin{matrix} \text{Saturday} & \text{Sunday} \end{matrix} \\ \begin{pmatrix} 84 & 51 \\ 135 & 160 \\ 72 & 87 \end{pmatrix} & \begin{matrix} \text{Children} \\ \text{Adults} \\ \text{Senior Citizens} \end{matrix} \end{matrix}$$

- (a) The concert tickets were priced at \$6 for a child, \$15 for an adult and \$8 for a senior citizen.  
 Represent this information in a  $1 \times 3$  matrix  $\mathbf{P}$ .

*Answer*  $\mathbf{P} = \dots\dots\dots$  [1]

- (b) Evaluate the matrix  $\mathbf{T} = \mathbf{PM}$ .

*Answer*  $\mathbf{T} = \dots\dots\dots$  [2]

- (c) State what each of the elements in matrix  $\mathbf{T}$  represents.

*Answer*  $\dots\dots\dots$   
 $\dots\dots\dots$  [1]

- (d) The elements of the matrix  $\mathbf{N}$ , where  $\mathbf{N} = \mathbf{QM}$ , represents the number of tickets sold on each day of the concert.  
 Write down the matrix  $\mathbf{Q}$ .

*Answer*  $\mathbf{Q} = \dots\dots\dots$  [1]

---

- 21** The diagram shows a figure made up of four identical rectangles.  
The length of the rectangle is 7 cm longer than the breadth of the rectangle.  
The perimeter of this figure is 138 cm.

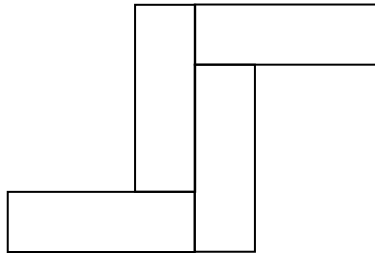

Find the area of this figure.

*Answer* .....  $\text{cm}^2$  [3]

---

- 22 In the diagram,  $OAB$  and  $OMN$  are sectors of two concentric circles with the same centre at  $O$ .  $OA = OB = 15$  cm and angle  $AOB = 2$  radians. The area of the shaded region is  $136$  cm<sup>2</sup>.

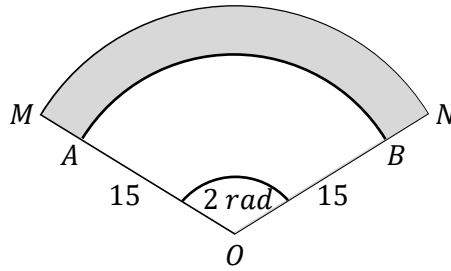

Find the length of  $AM$ .

Answer ..... cm [3]

---

23 The diagram shows a park  $PQRS$  and a path  $PR$ .

$S$  is due north of  $P$  and the bearing of  $R$  from  $P$  is  $018^\circ$ .

It is also given that  $PQ = 72$  m,  $QR = 45$  m,  $RS = 28$  m and  $PR = 90$  m.

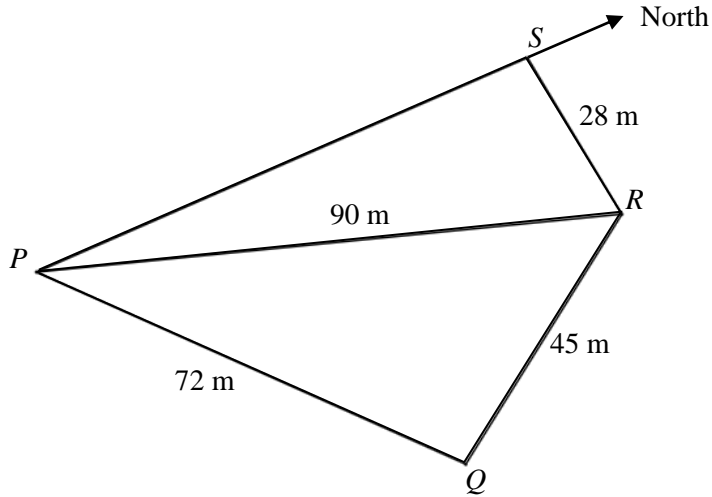

(a) Calculate

(i) angle  $PSR$ ,

Answer ..... $^\circ$  [2]

(ii) the bearing of  $P$  from  $R$ .

Answer ..... $^\circ$  [2]

(b) Show that angle  $PQR$  is  $97.903^\circ$ , correct to three decimal places.

*Answer*

[3]

(c) Find

(i) area of triangle  $PQR$ ,

*Answer* .....m<sup>2</sup> [2]

(ii) the shortest distance from  $Q$  to  $PR$ .

*Answer* ..... m [1]

(d) A lamp post stands vertically at point  $Q$ .

The greatest angle of elevation of the top of the lamp post when viewed from a point along  $PR$  is  $8^\circ$ .

Calculate the height of the lamp post.

*Answer* ..... m [2]

---

- 24  $OWXY$  is a parallelogram.  $P$  is a point on  $WX$  such that  $\overline{WP} = \frac{3}{5}\overline{WX}$ .  
 $\overline{YX} = 5\mathbf{a} + 4\mathbf{b}$  and  $\overline{OY} = 10\mathbf{a} - 5\mathbf{b}$ .

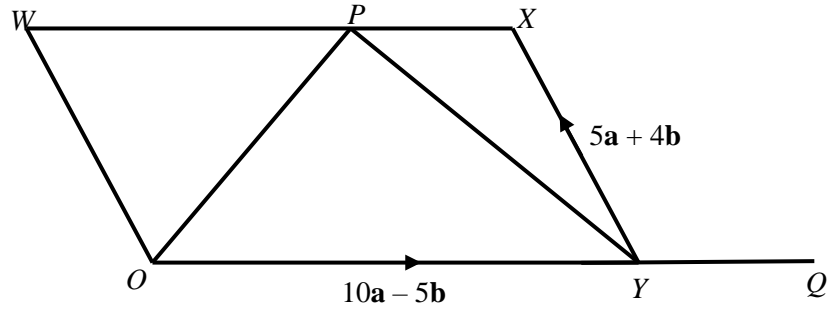

- (a) Find  $\overline{YP}$  in terms of  $\mathbf{a}$  and  $\mathbf{b}$ .

*Answer* ..... [2]

- (b)  $Q$  is on  $OY$  produced such that  $OY : YQ$  is  $5 : 2$ .  
 Show that  $\overline{QX}$  and  $\overline{YP}$  are equal vectors.

- (c) Find the value of  $\frac{\text{area of triangle } PXY}{\text{area of triangle } OPY}$  .

*Answer* ..... [1]

End of Paper

1.		<p>Method 1</p> $42.2\text{km} = 42200\text{m}$ $4\text{h } 45\text{min} = 17100\text{s}$ $\text{Speed} = \frac{42200}{17100}$ $= 2.47\text{m/s}$	<p>Method 2</p> $42.2 \div 4 \frac{3}{4} = 8.8842\text{km/h}$ $\frac{8.8842 \times 1000}{3600}$ $= 2.47\text{m/s}$
2.	a.	$\left(\frac{g^{12}}{256f^6}\right)^{-\frac{1}{4}} = \left(\frac{256f^6}{g^{12}}\right)^{\frac{1}{4}}$ $= \frac{256^{\frac{1}{4}} f^{\frac{6}{4}}}{g^{\frac{12}{4}}}$ $= \frac{4f^{\frac{3}{2}}}{g^3}$	
	b.	$5 \times 9^{k-1} = 15 \times 81$ $5 \times 3^{2(k-1)} = 3 \times 5 \times 3^4$ $3^{2(k-1)} = 3^5$ $2(k-1) = 5$ $k = 3.5$	
3.		55.2 or 124.8	
4.	a.	<p>Divisor <math>245 = 5 \times 7^2</math>  which is a factor of A.</p>	
	b.	$k = 2 \times 5 = 10$	
	c.	$A = 2^7 \times 5^{11} \times 7^8$ $B = 2^5 \times 3^6 \times 7^3$ $\text{HCF} = 2^5 \times 7^3$ $\text{LCM} = 2^7 \times 3^6 \times 5^{11} \times 7^8$	
5.		$42000 \left(1 + \frac{\left(\frac{1.6}{12}\right)}{100}\right)^{36}$ $= \$44063.76$	
6.	a.	$x^2 + 6x + 10 = x^2 + 6x + 3^2 - 3^2 + 10$ $= (x + 3)^2 + 1$	

	b.	(i) $x = -3$
		(ii) The minimum point of the graph is above the $x$ -axis.
7.	a.	Paul = 125% Mike $\rightarrow$ Mike = 80% Paul Mike = 75% Oscar $0.8 \text{ Paul} = 0.75 \text{ Oscar}$ Paul : Oscar = $0.75 : 0.8 = 15:16$
	b.	Total cost = $900 \times 8 = 7200$ Total received = $4 \times \frac{180}{100} \times 900 + 3 \times \frac{50}{100} \times 900 = 7830$ Profit = \$630
8.	a.	(i) $420h \pm 2$ (ii) $500 - 330 = 170h$
	b.	$x = 470$
9.	a.	Using $2y + 3x = 2$ , $y = -\frac{3}{2}x + 1$ , $y$ intercept = 1
	b.	$2(-4) + 3x = 2$ $D \left( \frac{10}{3}, -4 \right)$
10.		$\frac{7y}{y+3} - \frac{y+9}{3-y} = \frac{7y(3-y) - (y+9)(y+3)}{(y+3)(3-y)}$ $= \frac{21y - 7y^2 - y^2 - 12y - 27}{(y+3)(3-y)}$ $= \frac{9y - 8y^2 - 27}{(y+3)(3-y)} \text{ or } \frac{8y^2 - 9y + 27}{(y+3)(y-3)}$
11.	a.	(i) $33x^2y + 11xy = 11xy(3x + 1)$  (ii) $x^3 + x^2 - 9x - 9 = x^2(x + 1) - 9(x + 1)$ $= (x + 1)(x^2 - 9)$ $= (x + 1)(x + 3)(x - 3)$
	b.	$(x + 3y)(4x - 3y) = 4x^2 + 9xy - 9y^2$

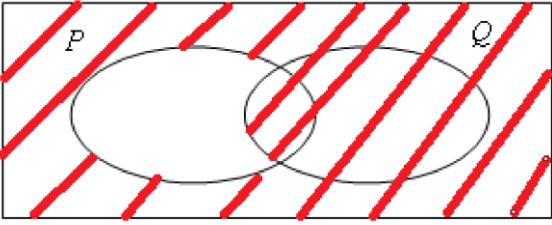
12.		<p>Blue: let there be <math>x</math> marbles</p> <p>Green: <math>x + 3</math></p> <p>Red: <math>2x + 3</math></p> <p>Total : <math>4x + 6</math></p> $P(\text{Blue}) = \frac{x}{4x + 6} = \frac{6}{25}$ $25x = 6(4x + 6)$ $x = 36$ <p>Green = 39</p>
13.		$x^2(3x - 10) + 2(x^3 + 10x - 8) - 4$ $= 3x^3 - 10x^2 + 2x^3 + 20x - 16 - 4$ $= 5x^3 - 10x^2 + 20x - 20$ $= 5(x^3 - 2x^2 + 4x - 4)$ <p>Since expression has a factor of 5 <b>OR</b> is a multiple of 5, it is divisible by 5 for any integer <math>x</math>.</p>
14.		<p>Interior angle of polygon C = <math>140^\circ</math></p> <p>Exterior angle of polygon C = <math>40^\circ</math></p> $\frac{360}{40} = 9 \text{ or } \frac{(n-2) \times 180}{n} = 140, n = 9$ <p>Polygon C can be a regular polygon with 9 equal sides with each interior angle <math>140^\circ</math>.</p>
15.		<p>The scale on the vertical axis is different and misleading.</p> <p>It can be misinterpreted that the average score for Company C is higher than Company D.</p>
16.	a)	
	b)	$\frac{5}{3} \leq x < \frac{35}{3}$ $x = \{2, 3, 4, 5, 6, 7, 8, 9, 10, 11\}$ <p>(i) <math>\{4, 8\}</math></p> <p>(ii) <math>A \not\subset B</math></p>

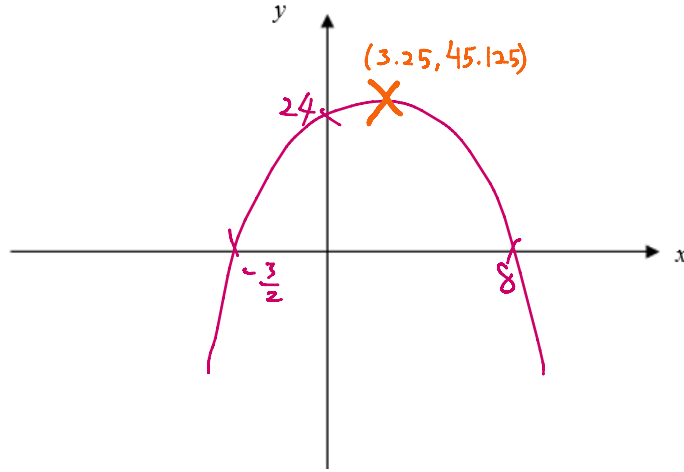
17.	
18.	$\frac{6x^2 - 7xy - 5y^2}{18x^2 - 50y^2} = \frac{(3x - 5y)(2x + y)}{2(3x + 5y)(3x - 5y)}$ $= \frac{(2x + y)}{2(3x + 5y)}$
19.	<p><math>y = k\sqrt{x}</math>          When <math>x</math> increased by 300%, <math>4x</math>  <math>y = k\sqrt{4x}</math>  <math>y = 2(k\sqrt{x})</math>  <math>y</math> is 2 times, i.e. increased by 1 times, 100%.  <math>r = 100\%</math></p>
20.	a) $\mathbf{P} = (6 \ 15 \ 8)$
	b) $(3105 \ 3402)$
	c) The total money collected from the ticket sales on Saturday and Sunday respectively.
	d) $(1 \ 1 \ 1)$
21.	<p>Breadth: let it be <math>x</math> cm.          Length: <math>x + 7</math> cm          Perimeter = <math>2 [(2x + 14) + (2x + 7)] = 138</math>  <math>x = 12</math>            area = <math>4 \times 12 \times 19 = 912 \text{ cm}^2</math></p>

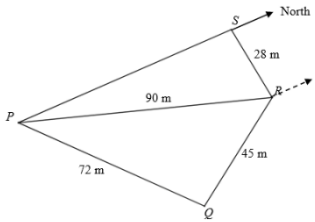
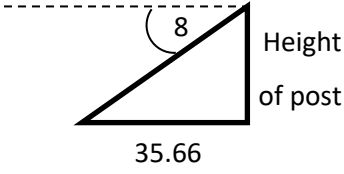
22.		<p>Let AM be <math>x</math> cm.</p> <p>Area of shaded region =</p> $\frac{1}{2}(15+x)^2(2) - \frac{1}{2}(15)^2(2) = 136$ $225 + 30x + x^2 - 225 - 136 = 0$ $x^2 + 30x - 136 = 0$ $x = -34 \text{ (rejected) or } 4$
23.	a)	<p>(i) <math>\frac{\sin PSR}{90} = \frac{\sin 18}{28}</math></p> <p><b>angle <math>PSR = 83.348 \approx 83.4^\circ</math></b></p>
		<p>(ii)</p> <p><b>angle <math>SRP = 180 - 83.348 - 18 = 78.652</math></b></p> <p><b>Bearing of P from R</b></p> <p><b><math>= 360 - 78.652 - 83.348 = 198.0^\circ</math></b></p> 
	b)	<p><math>\cos PQR = \frac{72^2 + 45^2 - 90^2}{2(72)(45)}</math></p> <p><b>angle <math>PQR = 97.903^\circ</math> (shown)</b></p>
	c)	<p>(i) <b>area <math>PQR = \frac{1}{2} \times 72 \times 45 \sin 97.903 = 1604.6 \approx 1600\text{m}^2</math></b></p> <p>(ii) <math>\frac{1}{2} \times 90 \times h = 1604.6</math></p> <p><b><math>h = 35.66 \approx 35.7\text{m}</math></b></p>
	d)	<p><math>\tan 8 = \frac{\text{height}}{35.66}</math></p> <p><b>height = 5.01m</b></p> <p>OR</p> <p><math>\tan 82 = \frac{35.66}{\text{height}}</math></p> <p><b>height = 5.01m</b></p> 

24.	a)	$\begin{aligned}\overrightarrow{XP} &= \frac{2}{5}\overrightarrow{YO} \\ &= \frac{2}{5}(-10\mathbf{a} + 5\mathbf{b}) \\ \overrightarrow{YP} &= \overrightarrow{YX} + \overrightarrow{XP} \\ &= (5\mathbf{a} + 4\mathbf{b}) + \frac{2}{5}(-10\mathbf{a} + 5\mathbf{b}) \\ &= \mathbf{a} + 6\mathbf{b}\end{aligned}$
	b)	$\begin{aligned}\overrightarrow{QY} &= \frac{2}{5}\overrightarrow{YO} = \overrightarrow{XP} \\ &= \frac{2}{5}(-10\mathbf{a} + 5\mathbf{b}) \\ \overrightarrow{QX} &= \overrightarrow{QY} + \overrightarrow{YX} \\ &= \frac{2}{5}(-10\mathbf{a} + 5\mathbf{b}) + (5\mathbf{a} + 4\mathbf{b}) \\ &= \mathbf{a} + 6\mathbf{b} = \overrightarrow{YP} \text{ (shown)}\end{aligned}$
	c)	$\frac{2}{5}$

Name: \_\_\_\_\_

--	--



# OUTRAM SECONDARY SCHOOL PRELIMINARY EXAMINATION 2024

**Subject** : **Mathematics**  
**Level (Stream)** : **Secondary Four Express  
& Five Normal Academic**  
**Paper** : **4052/02**  
**Date** : **23 August 2024**  
**Duration** : **2 hours 15 mins**  
**Marks** : **90**

### READ THESE INSTRUCTIONS FIRST

Write your name, class and index number on all the work you hand in.

Write in dark blue or black pen.

You may use an HB pencil for any diagrams or graphs.

Do not use staples, paper clips, highlighters, glue or correction fluid.

Answer **all** questions on the Question Paper.

If working is needed for any question it must be shown with the answer.

Omission of essential working will result in loss of marks.

The use of an approved scientific calculator is expected, where appropriate.

If the degree of accuracy is not specified in the question, and if the answer is not exact, give the answer to three significant figures. Give answers in degrees to one decimal place.

For  $\pi$ , use either your calculator value or 3.142, unless the question requires the answer in terms of  $\pi$ .

The number of marks is given in brackets [ ] at the end of each question or part question.

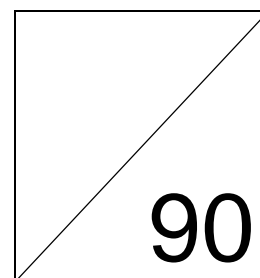

**Mathematical Formulae***Compound interest*

$$\text{Total amount} = P \left( 1 + \frac{r}{100} \right)^n$$

*Mensuration*

$$\text{Curved surface area of a cone} = \pi r l$$

$$\text{Surface area of a sphere} = 4\pi r^2$$

$$\text{Volume of a cone} = \frac{1}{3} \pi r^2 h$$

$$\text{Volume of a sphere} = \frac{4}{3} \pi r^3$$

$$\text{Area of triangle } ABC = \frac{1}{2} ab \sin C$$

$$\text{Arc length} = r\theta, \text{ where } \theta \text{ is in radians}$$

$$\text{Sector area} = \frac{1}{2} r^2 \theta, \text{ where } \theta \text{ is in radians}$$

*Trigonometry*

$$\frac{a}{\sin A} = \frac{b}{\sin B} = \frac{c}{\sin C}$$

$$a^2 = b^2 + c^2 - 2bc \cos A$$

*Statistics*

$$\text{Mean} = \frac{\sum fx}{\sum f}$$

$$\text{Standard deviation} = \sqrt{\frac{\sum fx^2}{\sum f} - \left( \frac{\sum fx}{\sum f} \right)^2}$$

Answer **all** the questions.

**1 (a)** It is given that 1 microgram =  $10^{-6}$  grams and 1 milligram =  $10^{-3}$  grams.

**(i)** If 1 milligram =  $p$  micrograms, find the integer value of  $p$ .

*Answer*  $p = \dots\dots\dots$  [1]

**(ii)** The recommended daily amount of vitamin A intake for an adult man is 900 micrograms. The amount of vitamin A in half a cup of boiled spinach is about 0.573 milligrams.

An adult man consumed one cup of boiled spinach in a day.

Explain whether he has met the daily recommended intake of vitamin A.

.....

.....

..... [2]

**(b)** A map has a scale of 1 : 30 000.

**(i)** The distance on the map between Town A and Town B is 8.5 cm. Find the actual distance, in km, between Town A and Town B.

*Answer* ..... km [1]

**(ii)** On the same map, the actual area of a pond is  $0.36 \text{ km}^2$ . Find the area of the pond represented on the map.

*Answer* .....  $\text{cm}^2$  [2]

- (iii) The same pond has an area of  $0.5625 \text{ cm}^2$  on another map with a scale of  $1 : n$ . Find the value of  $n$ .

*Answer*  $n = \dots\dots\dots$  [2]

---

2 (a)  $2xz = \frac{4y - z^2}{3z}$

- (i) Find  $y$  when  $x = 3$  and  $z = -1$ .

*Answer*  $y = \dots\dots\dots$  [2]

- (ii) Express  $z$  in terms of  $x$  and  $y$ .

*Answer*  $z = \dots\dots\dots$  [3]

(b) Solve the inequality  $3 - x < \frac{7 - 3x}{2} \leq 6$ .

*Answer* ..... [2]

(c) Solve the equation  $\frac{2}{x+1} + \frac{5}{2x-5} = 1$ .

*Answer* ..... [4]

---

- 3 The diagram shows an open funnel, consisting of a cylinder and a cone. The heights of the cylinder and cone are  $1.5h$  cm each, and the radius of both the cylinder and cone is  $0.8h$  cm.

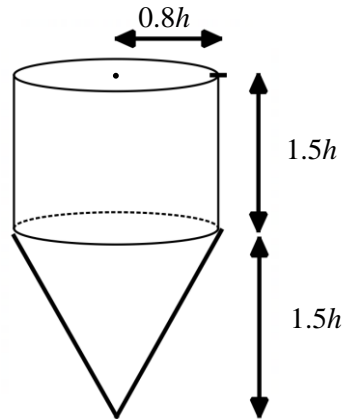

- (a) Show that the curved surface area of the cone is  $1.36\pi h^2$ .

*Answer*

[2]

- (b) Given that the total surface area of the funnel is  $1504\pi$  cm<sup>2</sup>, find the value of  $h$ .

*Answer*  $h = \dots\dots\dots$  [2]

- (c) A glass rod is placed in the funnel so that the one end of the glass rod rests on the edge of the funnel as shown.

When the glass rod is placed vertically from the bottom of the funnel, a part of the glass rod protrudes from the top of the funnel.

Calculate this length of the part of the glass rod that is outside the funnel when placed vertically.

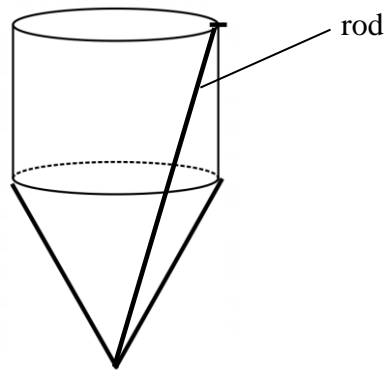

*Answer* ..... cm [3]

- (d) Water is being poured into the funnel at a constant rate and it takes 16 seconds to fill the funnel completely.

Sketch the change in height of the water level with respect to time, showing all critical values clearly.

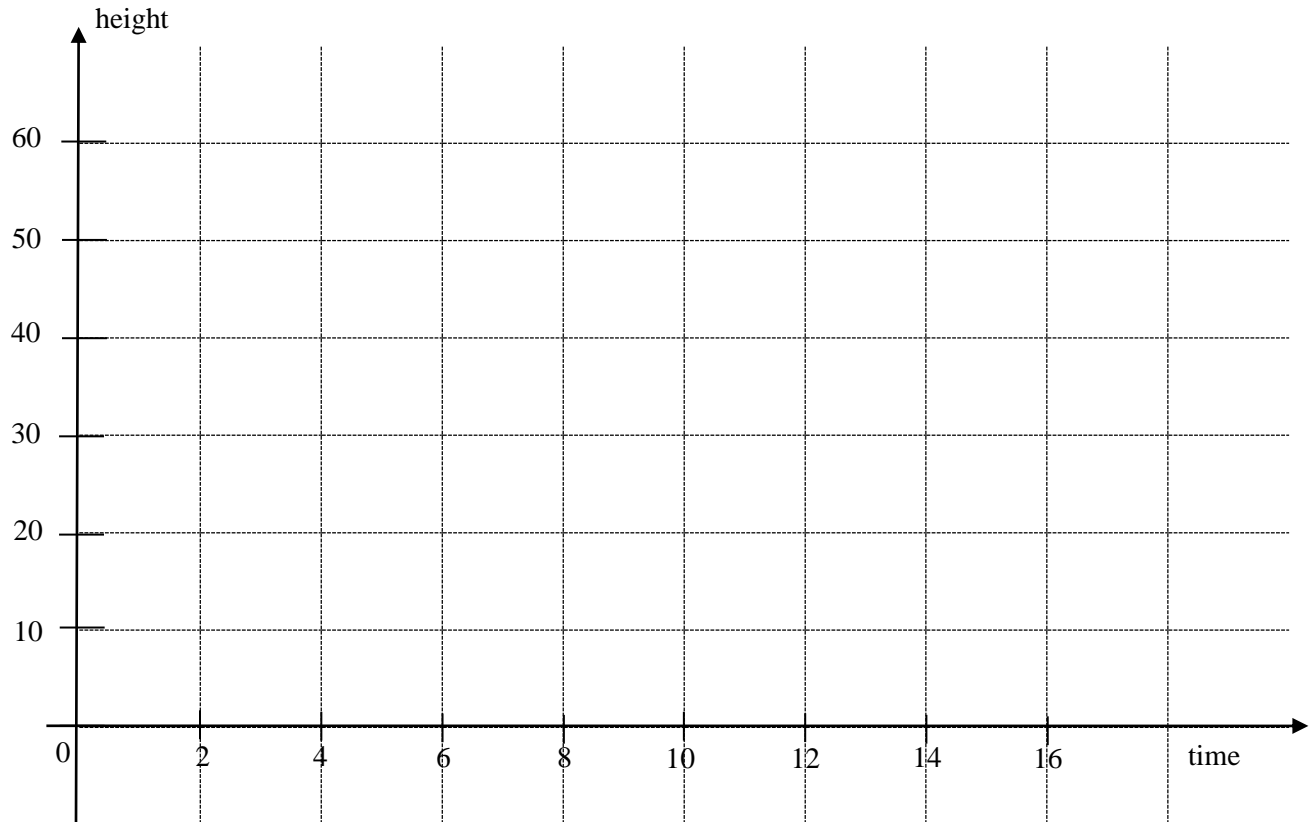

[2]

---

- 4 The cost, \$y\$, of making a round plate of radius  $x$  cm is given by the function  $y = ax^2 + \frac{210}{x}$ , where  $a$  is a constant.

(a) Given that  $x = 2$ ,  $y = 107$ , show that  $a = \frac{1}{2}$ .

*Answer*

[1]

- (b) The table below shows some of the corresponding values of  $x$  and  $y$ .

$x$	2	4	6	8	10	12
$y$	107	60.5	53	58.3	71	$p$

Find  $p$ .

*Answer*  $p = \dots\dots\dots$  [1]

- (c) On the grid, draw the graph for  $y = ax^2 + \frac{210}{x}$  for  $2 \leq x \leq 12$ .

[3]

- (d) Using your graph,

- (i) find the radius which gives the minimum cost,

*Answer*  $\dots\dots\dots$  cm [1]

- (ii) the range of value of  $x$  such that the cost is below \$70.

*Answer*  $\dots\dots\dots$  [1]

(e) (i) On the same grid as in part (b), draw the line  $6y = 25x + 180$ . [2]

(ii) Write down the  $x$ -coordinate of the points where the line intersects the curve.

*Answer*  $x = \dots\dots\dots$  and  $\dots\dots\dots$  [2]

(iii) These values of  $x$  are the solutions of the equation  $x^3 + Ax^2 + Bx + C = 0$ .  
Find the values of  $A$ ,  $B$  and  $C$ .

*Answer*  $A = \dots\dots\dots$

$B = \dots\dots\dots$

$C = \dots\dots\dots$  [3]

---

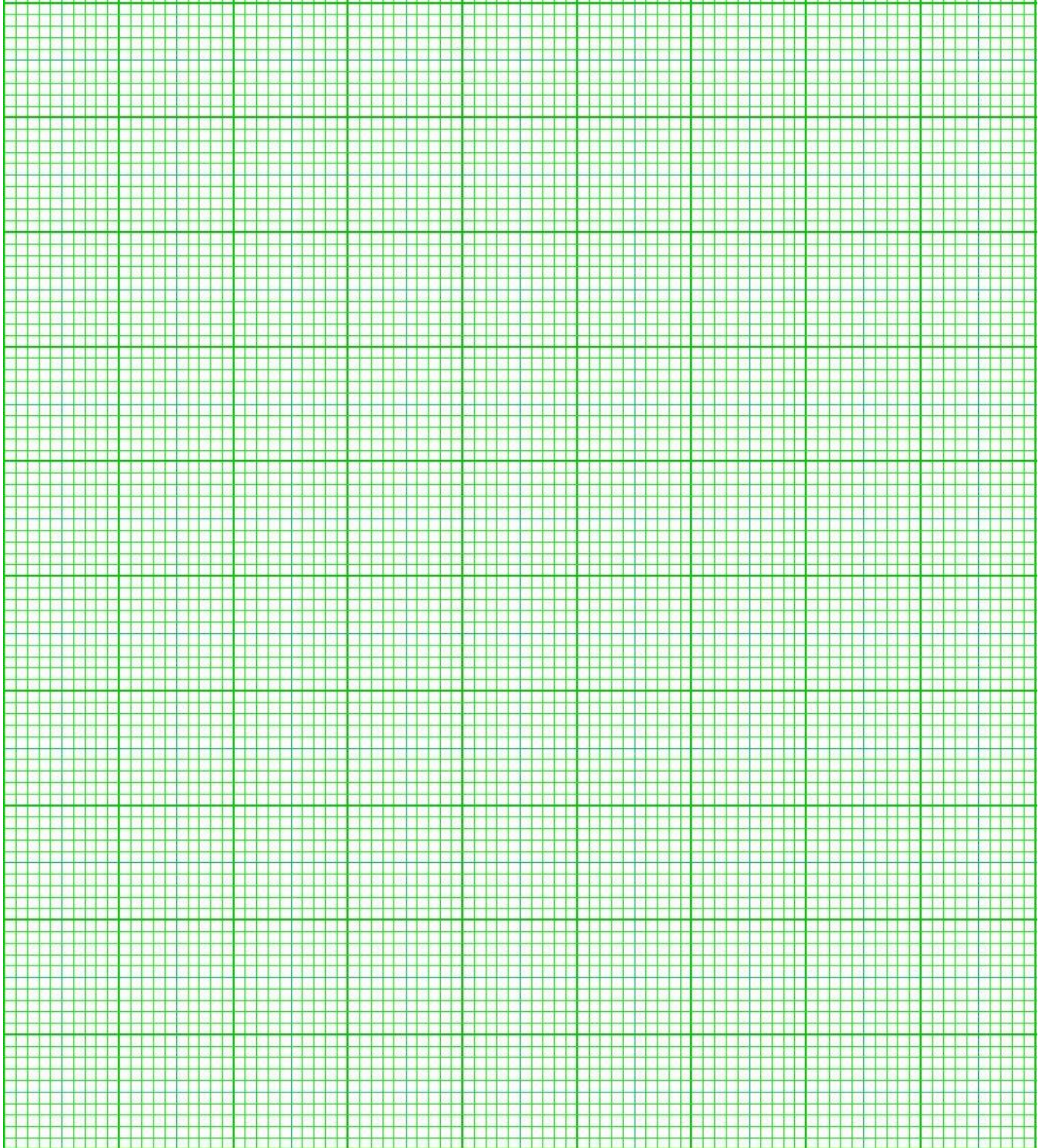

- 5 (a) The circle  $BCDE$  has a centre  $O$ .  $AB$  and  $AC$  are tangents to the circle.  $COE$  is a straight line. Angle  $CED = 60^\circ$  and  $DF = FB$ .

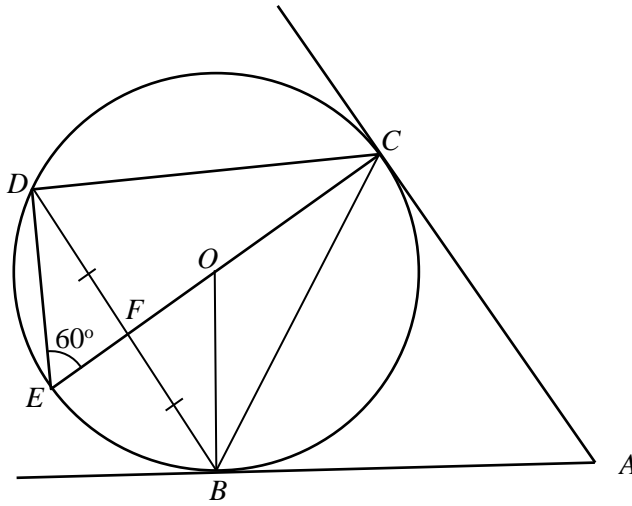

- (i) Prove, stating your reasons clearly, that triangle  $BCD$  is equilateral.

*Answer*

[3]

- (ii) Find angle  $BAC$ .

*Answer* angle  $BAC = \dots\dots\dots^\circ$  [1]

- (b) The first three terms in a sequence of numbers,  $T_1, T_2, T_3, \dots$  are given below.

$$T_1 = \frac{1}{2}(2 \times 3) = 3$$

$$T_2 = \frac{1}{2}(3 \times 4) = 6$$

$$T_3 = \frac{1}{2}(4 \times 5) = 10$$

- (i) Find  $T_7$ .

*Answer*  $T_7 = \dots\dots\dots$  [1]

- (ii) Find an expression, in terms of  $n$ , for  $T_n$ .

*Answer*  $T_n = \dots\dots\dots$  [1]

- (iii) 351 is a term in the sequence.  
Find the value of  $n$ .

*Answer*  $n = \dots\dots\dots$  [2]

---

- 6 (a)** The position vector of point  $P$  is  $\begin{pmatrix} -3 \\ 4 \end{pmatrix}$  and the position vector of point  $Q$  is  $\begin{pmatrix} 2 \\ m \end{pmatrix}$ , where  $m < 0$ .

- (i)**  $|\overline{PQ}| = 13$  units  
Find  $m$ .

*Answer*  $m = \dots\dots\dots$  [3]

- (ii)** Given that  $\overrightarrow{QP} = 2\overrightarrow{PR}$ , find the coordinates of point  $R$ .

*Answer*  $R$  (  $\dots\dots\dots$  ,  $\dots\dots\dots$  ) [3]

(b)

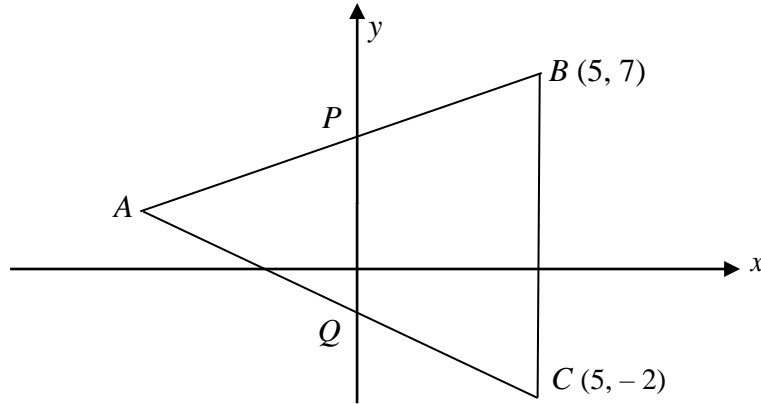

The coordinates of  $B$  and  $C$  are  $(5, 7)$  and  $(5, -2)$  respectively. Lines  $AB$  and  $AC$  intersect the  $y$ -axis at  $P$  and  $Q$  respectively.

- (i) The gradient of  $AB$  is  $\frac{2}{3}$ .  
Find the equation of the line  $AB$ .

*Answer* ..... [2]

- (ii) The  $y$ -coordinate of  $A$  is 1.  
Find the area of triangle  $ABC$ .

*Answer* ..... units<sup>2</sup> [2]

- (iii) Explain why triangle  $APQ$  and triangle  $ABC$  are similar.

.....

.....

.....

..... [2]

- 7 (a) The box-and-whisker plot below shows the results of a science test for class A. The median mark for class A is 66 and the inter-quartile range is 31. 65 of the students scored 80 marks or better. This is also the 75<sup>th</sup> percentile.



- (i) On the diagram, label the marks for lower quartile, upper quartile and the median.

[2]

- (ii) Work out the number of students who did the science test.

*Answer* ..... [1]

- (iii) The median mark for the science test for class B is 63, and the inter-quartile range is 30.

Make 2 comments on the marks for the science test for classes A and B. Use figures to support your answer.

*Comment 1* .....

.....

*Comment 2* .....

.....

[2]



- 8**  $OABC$  is a right pyramid with vertex  $O$  vertically above its base, an equilateral triangle  $ABC$ . A small similar pyramid  $OGFH$  is removed from the top of pyramid  $OABC$ .  $BC = 8$  cm.  $ONP = 20$  cm, where line  $ONP$  is a straight line perpendicular to the base.

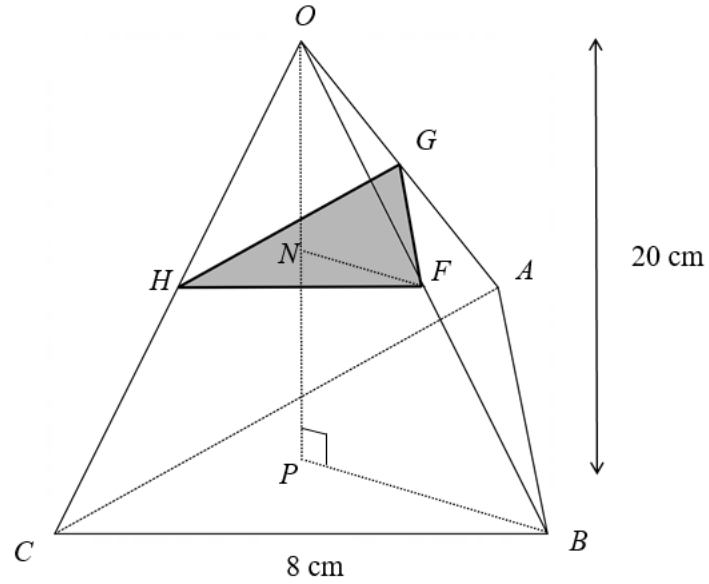

- (a)** Show that the volume of pyramid  $OABC$  is  $185 \text{ cm}^3$ , correct to the nearest  $\text{cm}^3$ .

*Answer*

- (b) Given that the volume of pyramid  $OGFH$  is  $39.96 \text{ cm}^3$ , find the value of  $\frac{\text{area of triangle } FGH}{\text{area of triangle } BAC}$ .

*Answer* ..... [3]

- (c) The remaining vertical height of the solid,  $NP$ , is 8 cm.  
Calculate the area of the top  $FGH$  of the remaining solid.

*Answer* .....  $\text{cm}^2$  [2]

---

- 9 A group of students plans to sell all-day breakfast sets during the school carnival in order to raise funds for a charity. Each breakfast set consists of 2 scrambled eggs, 2 slices of bread, 1 sausage, 1 slice of chicken ham and a cup of coffee.

The students estimate that they will sell 300 all-day breakfast sets. The costs of the ingredients used are as follows.

<b>Item</b>	<b>Description</b>	<b>Unit cost</b>
<b>Eggs</b>	Pasar Fresh Eggs (10 per pack)	\$2.70
	Pasar Fresh Eggs (30 per pack)	\$6.90
	Dasun Fresh Eggs (15 per pack)	\$4.55
<b>Bread</b>	Garden Soft White Bread (14 slices)	\$2.70
	Sunny Soft White Bread (12 slices)	\$2.50
<b>Sausages</b>	Chicken Frank (10 per pack)	\$5.25
	Chef Sausages (6 per pack) (\$0.35 off per 2 packs)	\$3.20
<b>Ham</b>	FP Baked Ham (10 per pack) (20% off per 3 packs)	\$4.35
	SC Baked Ham (10 per pack)	\$3.30
<b>Coffee</b>	Nescafe Instant Coffee (35 per pack) (Buy 5 get 1 free)	\$6.15
	Indocafe Coffeemix (25 per pack)	\$3.95

- (a) Find the lowest possible total cost of the ingredients required for the 300 all-day breakfast sets.

*Answer*

- (b) The school provides \$200 in funding for the students and has set two criteria which every class must meet:

**Criteria 1:** Up to 40% of the sales will be used to cover their expenses, while the remaining goes to the charity.

**Criteria 2:** The students must raise at least \$600 for charity.

Find the minimum price (to the nearest ten cents) they must charge for each breakfast set such that this group of students meets both criteria.

Justify your answer, showing all necessary workings clearly.  
State an assumption you have made in your calculations.

*Answer*

**Blank Page**



1.	a)	<p>(i) 1000</p> <p>(ii) <math>0.573\text{mg} \times 2 = 1.146\text{mg} = 1146\mu\text{g}</math> Yes, he met the daily recommended intake.</p>
	b)	<p>(i) 2.55km</p> <p>(ii) Area scale <math>1\text{cm}^2 : 0.09\text{km}^2</math> Area on map = <math>0.36 \div 0.09 = 4 \text{ cm}^2</math></p> <p>(iii) <math>0.5625 \text{ cm}^2 : 0.36 \text{ km}^2</math> <math>1 \text{ cm}^2 : 0.64 \text{ km}^2</math> <math>1 \text{ cm} : 0.8 \text{ km}</math> <math>n = 80000</math></p>
2.	a)	$2xz = \frac{4y - z^2}{3z}$ <p>(i)</p> $2(3)(-1) = \frac{4y - (-1)^2}{3(-1)}$ $y = \frac{19}{4} \text{ or } 4.75$
		<p>(ii)</p> $2xz = \frac{4y - z^2}{3z}$ $2xz(3z) = 4y - z^2$ $6xz^2 + z^2 = 4y$ $z^2(6x + 1) = 4y$ $z = \pm \sqrt{\frac{4y}{6x + 1}}$
	b)	$3 - x < \frac{7 - 3x}{2} \leq 6$ $6 - 2x < 7 - 3x \text{ and } 7 - 3x \leq 12$ $x < 1 \text{ and } -3x \leq 5$ $x \leq -\frac{5}{3}$

	c)	$\frac{2}{x+1} + \frac{5}{2x-5} = 1$ $2(2x-5) + 5(x+1) = (x+1)(2x-5)$ $4x-10+5x+5 = 2x^2 - 3x - 5$ $2x^2 - 12x = 0$ $2x(x-6) = 0$ $x = 0 \text{ or } 6$
3.	a)	<p>Slant height of cone <math>= \sqrt{(0.8h)^2 + (1.5h)^2}</math></p> $= \sqrt{2.89h^2}$ $= 1.7h$ <p>Curved area of cone <math>= \pi \times 0.8h \times 1.7h</math></p> $= 1.36\pi h^2 \text{ (shown)}$
	b)	<p>Total surface area <math>= 1.36\pi h^2 + 2\pi(0.8h)(1.5h)</math></p> $= 3.76\pi h^2 = 1504\pi$ $h^2 = \frac{1504}{3.76}$ $h = 20\text{cm}$
	c)	<p>Radius = 16 cm, full height = 60 cm</p> <p>Length of rod <math>= \sqrt{16^2 + 60^2} = 62.097</math></p> <p>Length outside funnel = 2.1 cm</p>
	d)	
4	a)	$107 = a(2)^2 + \frac{210}{2}$ $a = \frac{1}{2}$
	b)	$p = \frac{1}{2}(12)^2 + \frac{210}{12}$ $p = 89.5$
	c)	Refer to graph
	d)	<p>(i) <math>5.9 \pm 0.2</math></p> <p>(ii) <math>3.2 &lt; x &lt; 9.9 \pm 0.2</math></p>
	e)	<p>(i) refer to graph</p> <p>(ii) <math>x = 5.6 \text{ or } 10.2 \pm 0.2</math></p>

		<p>(iii) <math>6y = 25x + 180 \rightarrow y = \frac{25}{6}x + 30</math></p> $y = \frac{1}{2}x^2 + \frac{210}{x}$ $\frac{1}{2}x^2 + \frac{210}{x} - \frac{25}{6}x - 30 = 0$ $\frac{1}{2}x^3 - \frac{25}{6}x^2 - 30x + 210 = 0$ $x^3 - \frac{25}{3}x^2 - 60x + 420 = 0$ <p>By comparing coefficients with <math>x^3 + Ax^2 + Bx + C = 0</math>,</p> $A = \frac{25}{3}, B = -60, C = 420$
5	a)	<p>(i) Angle CBD = CED, angles in the same segment</p> <p>Angle DFE = 90°, OE bisects chord BD          Angle FDE = 30°, angle sum in a triangle DFE          Angle CDE = 90°, angle in a semi circle          Angle BDC = 90 - 30 = 60°</p> <p>Angle CBD = 60°, angle sum in triangle BCD          Hence Triangle BCD is an equilateral triangle.</p>
		<p><b>OR</b></p> <p>Angle CBD = CED, angles in the same segment</p> <p>Angle BED = 2×60 = 120° (OE bisects chord BD, Triangle DEF and BEF are congruent)</p> <p>Angle CBD = 60°, angle sum in triangle BCD          Hence Triangle BCD is an equilateral triangle.</p>
		<p>(ii) Angle BOC = 120°, angle at centre = 2x angle at circumference          Angle BAC = 360 - 90 - 90 - 120 = 60°</p>
	b)	<p>(i) <math>T_7 = 36</math></p>
		<p>(ii) <math>T_n = \frac{1}{2}(n+1)(n+2)</math></p>

		(iii) $(n+1)(n+2) = 351$ $n^2 + 3n + 2 = 702$ $n^2 + 3n - 700 = 0$ $n = -28(\text{reject}) \text{ or } 25$ $n = 25$
--	--	--

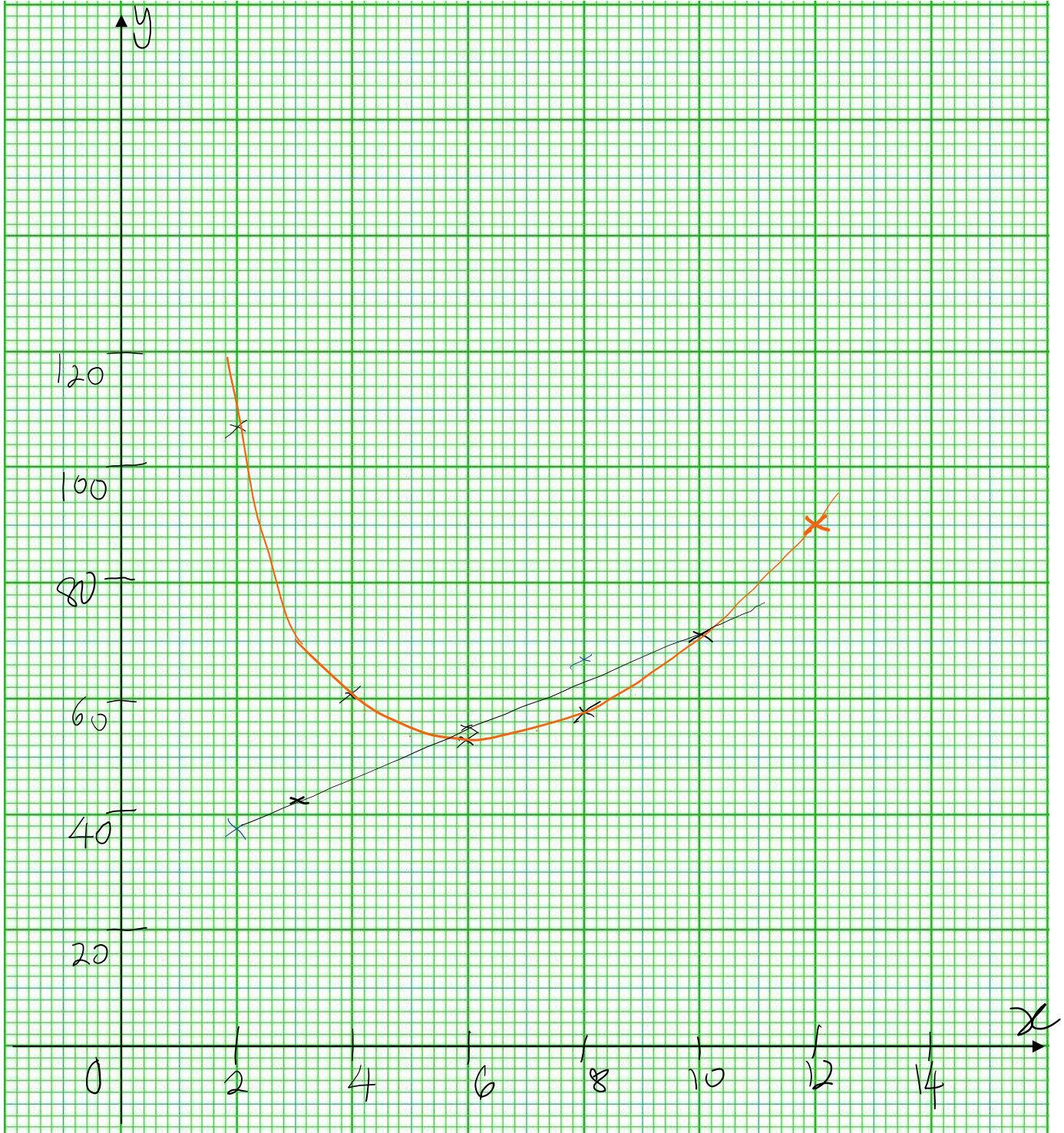

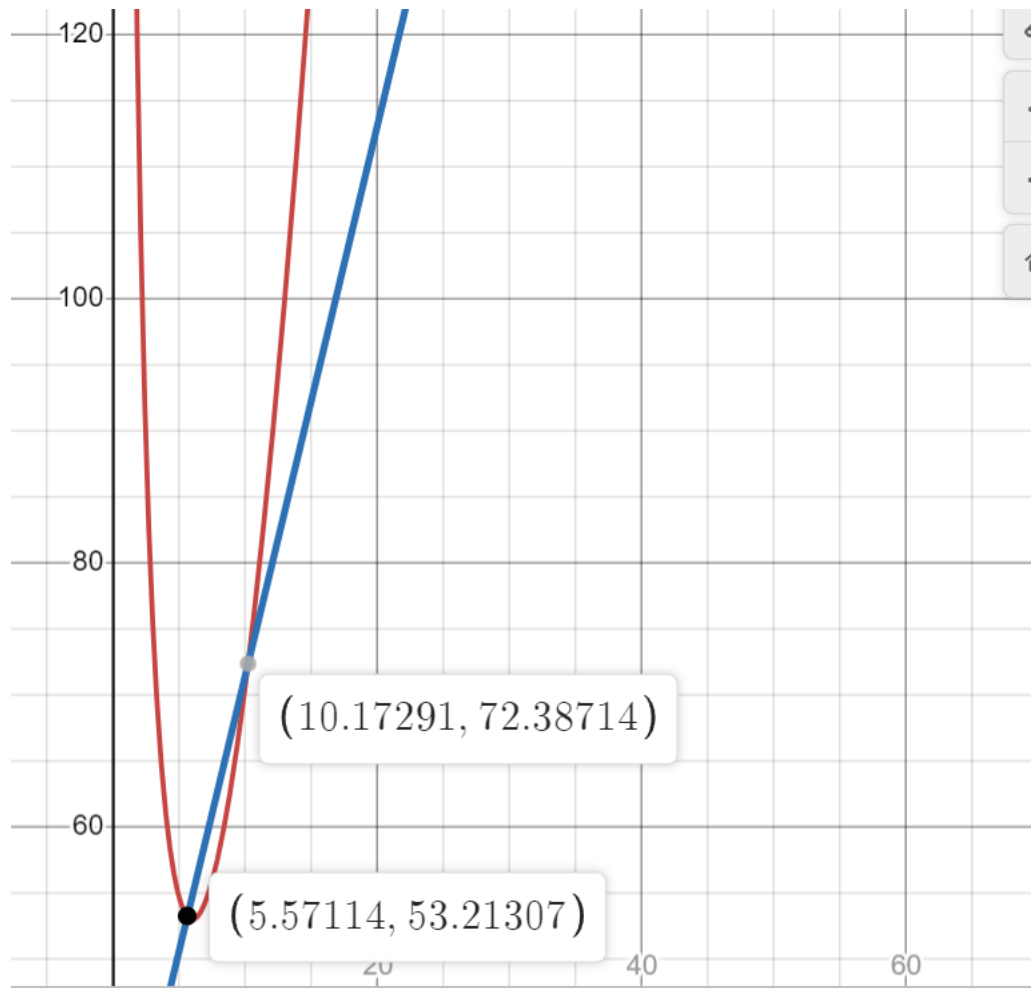

6	a)	<p>(i)</p> $\begin{aligned}\vec{PQ} &= \vec{OQ} - \vec{OP} \\ &= \begin{pmatrix} 2 \\ m \end{pmatrix} - \begin{pmatrix} -3 \\ 4 \end{pmatrix} \\ &= \begin{pmatrix} 5 \\ m-4 \end{pmatrix}\end{aligned}$ $ \vec{PQ}  = \sqrt{5^2 + (m-4)^2} = 13 \text{ units}$ $25 + m^2 - 8m + 16 = 169$ $m^2 - 8m - 128 = 0$ $m = -8 \text{ or } 16 \text{ (rejected)}$ $m = -8$
		<p>(ii)</p> $\vec{QP} = 2\vec{PR}$ $\vec{QP} = \begin{pmatrix} -5 \\ 12 \end{pmatrix}$ $\vec{QP} = 2\vec{PR}$ $\frac{1}{2} \begin{pmatrix} -5 \\ 12 \end{pmatrix} = \vec{OR} - \vec{OP}$ $\begin{pmatrix} -2.5 \\ 6 \end{pmatrix} + \begin{pmatrix} -3 \\ 4 \end{pmatrix} = \vec{OR}$ $\vec{OR} = \begin{pmatrix} -5.5 \\ 10 \end{pmatrix}$ $R(-5.5, 10)$
	b)	<p>(i)</p> $y = \frac{2}{3}x + C$ <p>When <math>x = 5, y = 7, C = \frac{11}{3}</math></p> $y = \frac{2}{3}x + \frac{11}{3}$ <p>(ii)</p> <p>Let <math>y = 1, x = -4</math></p> $\text{area} = \frac{1}{2} \times 9 \times 9 = 40.5 \text{ units}^2$
		<p>(iii) <math>PQ</math> and <math>BC</math> are parallel  Angle <math>PAQ =</math> Angle <math>BAQ</math> (common)  Angle <math>APQ =</math> Angle <math>ABC</math> (corresponding angle)  Triangle <math>APQ</math> and <math>ABC</math> are similar</p>
7	a)	(i)

		<p>(ii) 260</p> <p>(iii) Students in class A has a higher score for the science test than class B. The median marks for class A is higher than B.</p> <p>Students in class A has a less consistent score than class B. The interquartile range for class A is higher than class B.</p>
	b)	(i) mean = 51 Standard deviation = 9.165 ≈ 9.17
		(ii) a) $\frac{18}{80} \times \frac{17}{79} = \frac{153}{3160}$ or 0.0484 b) $\frac{6}{80} \times \frac{32}{79} + \frac{32}{80} \times \frac{6}{79} = \frac{24}{395}$
8	a)	Vol of pyramid = $\frac{1}{3} \left( \frac{1}{2} \times 8 \times 8 \times \sin 60 \right) \times 20$ = 184.75 cm <sup>3</sup>
	b)	$\frac{V_1}{V_2} = \frac{39.96}{185} = \frac{27}{125}$ $\frac{l_1}{l_2} = \sqrt[3]{\left( \frac{27}{125} \right)} = \frac{3}{5}$ $\frac{A_1}{A_2} = \left( \frac{3}{5} \right)^2 = \frac{9}{25}$
	c)	Method 1 $HF = \frac{3}{5} \times 8 = 4.8$ area of triangle FGH = $\frac{1}{2} \times 4.8 \times 4.8 \sin(60)$ = 9.98 cm <sup>2</sup> Method 2 area of triangle FGH = $\frac{9}{25} \times \frac{1}{2} \times 6 \times 6 \sin(60)$ = 9.98 cm <sup>2</sup>

9	<p>a) Compare unit cost</p> <p>1 Egg</p> <table border="1" style="margin-left: 40px;"> <thead> <tr> <th>Type</th> <th>Cost</th> <th>Sets</th> </tr> </thead> <tbody> <tr> <td>Pasar 10</td> <td>0.27</td> <td>60 trays</td> </tr> <tr> <td>Pasar 30</td> <td>0.23</td> <td>20 trays</td> </tr> <tr> <td>Dasun 15</td> <td>0.3033</td> <td>40 trays</td> </tr> </tbody> </table> <p>1 Bread</p> <table border="1" style="margin-left: 40px;"> <tbody> <tr> <td>Garden14</td> <td>0.1928</td> <td>22 loaves</td> </tr> <tr> <td>Sunny12</td> <td>0.2083</td> <td>25 loaves</td> </tr> </tbody> </table> <p>1 Sausages</p> <table border="1" style="margin-left: 40px;"> <tbody> <tr> <td>Chicken F 10</td> <td>0.525</td> <td>30 packs</td> </tr> <tr> <td>Chef S 6</td> <td>0.504</td> <td>50 packs</td> </tr> </tbody> </table> <p>1 Ham</p> <table border="1" style="margin-left: 40px;"> <tbody> <tr> <td>FP 10</td> <td>0.435</td> <td>30 packs</td> </tr> <tr> <td>SC 10</td> <td>0.33</td> <td>30 packs</td> </tr> </tbody> </table> <p>1 coffee</p> <table border="1" style="margin-left: 40px;"> <tbody> <tr> <td>Nes35</td> <td>6.15</td> <td>9 packs</td> </tr> <tr> <td>Ind 25</td> <td>3.95</td> <td>12 packs</td> </tr> </tbody> </table> <p>Lowest possible cost  <b>138 + 116.10 + 151.25 + 99 + 47.40 = \$551.75</b></p>	Type	Cost	Sets	Pasar 10	0.27	60 trays	Pasar 30	0.23	20 trays	Dasun 15	0.3033	40 trays	Garden14	0.1928	22 loaves	Sunny12	0.2083	25 loaves	Chicken F 10	0.525	30 packs	Chef S 6	0.504	50 packs	FP 10	0.435	30 packs	SC 10	0.33	30 packs	Nes35	6.15	9 packs	Ind 25	3.95	12 packs	<p>Compare cost for 300 sets</p> <p>600 eggs</p> <table border="1" style="margin-left: 40px;"> <thead> <tr> <th>Type</th> <th>Cost</th> <th>Sets</th> </tr> </thead> <tbody> <tr> <td>Pasar 10</td> <td>162</td> <td>60 trays</td> </tr> <tr> <td>Pasar 30</td> <td><u>138</u></td> <td>20 trays</td> </tr> <tr> <td>Dasun 15</td> <td>182</td> <td>40 trays</td> </tr> </tbody> </table> <p>600 Breads</p> <table border="1" style="margin-left: 40px;"> <tbody> <tr> <td>Garden14</td> <td><u>116.10</u></td> <td>43loaves</td> </tr> <tr> <td>Sunny12</td> <td>125</td> <td>50loaves</td> </tr> </tbody> </table> <p>300 Sausages</p> <table border="1" style="margin-left: 40px;"> <tbody> <tr> <td>Chicken F 10</td> <td>157.50</td> <td>30 packs</td> </tr> <tr> <td>Chef S 6</td> <td>160</td> <td>50 packs</td> </tr> <tr> <td></td> <td><u>151.25</u> (0.35disc)</td> <td></td> </tr> </tbody> </table> <p>300 Ham</p> <table border="1" style="margin-left: 40px;"> <tbody> <tr> <td>FP 10</td> <td>130.50 104.40 (20%disc)</td> <td>30 packs</td> </tr> <tr> <td>SC 10</td> <td><u>99</u></td> <td>30 packs</td> </tr> </tbody> </table> <p>300 coffee</p> <table border="1" style="margin-left: 40px;"> <tbody> <tr> <td>Nes35</td> <td>55.35 49.20 (disc1)</td> <td>9 packs</td> </tr> <tr> <td>Ind 25</td> <td><u>47.40</u></td> <td>12 packs</td> </tr> </tbody> </table>	Type	Cost	Sets	Pasar 10	162	60 trays	Pasar 30	<u>138</u>	20 trays	Dasun 15	182	40 trays	Garden14	<u>116.10</u>	43loaves	Sunny12	125	50loaves	Chicken F 10	157.50	30 packs	Chef S 6	160	50 packs		<u>151.25</u> (0.35disc)		FP 10	130.50 104.40 (20%disc)	30 packs	SC 10	<u>99</u>	30 packs	Nes35	55.35 49.20 (disc1)	9 packs	Ind 25	<u>47.40</u>	12 packs
Type	Cost	Sets																																																																											
Pasar 10	0.27	60 trays																																																																											
Pasar 30	0.23	20 trays																																																																											
Dasun 15	0.3033	40 trays																																																																											
Garden14	0.1928	22 loaves																																																																											
Sunny12	0.2083	25 loaves																																																																											
Chicken F 10	0.525	30 packs																																																																											
Chef S 6	0.504	50 packs																																																																											
FP 10	0.435	30 packs																																																																											
SC 10	0.33	30 packs																																																																											
Nes35	6.15	9 packs																																																																											
Ind 25	3.95	12 packs																																																																											
Type	Cost	Sets																																																																											
Pasar 10	162	60 trays																																																																											
Pasar 30	<u>138</u>	20 trays																																																																											
Dasun 15	182	40 trays																																																																											
Garden14	<u>116.10</u>	43loaves																																																																											
Sunny12	125	50loaves																																																																											
Chicken F 10	157.50	30 packs																																																																											
Chef S 6	160	50 packs																																																																											
	<u>151.25</u> (0.35disc)																																																																												
FP 10	130.50 104.40 (20%disc)	30 packs																																																																											
SC 10	<u>99</u>	30 packs																																																																											
Nes35	55.35 49.20 (disc1)	9 packs																																																																											
Ind 25	<u>47.40</u>	12 packs																																																																											

	<p>b) Possible solution 1 Let the selling price be \$x. Total sales = \$300x To meet cover expenses criteria 40% of sales = 551.75 100% of sales = <math>551.75 \div 40\% = 1379.375</math> 60% of sales = <math>1379.375 \times 60\% = 827.625</math> Meets the donation criteria T3 Selling price of each set = <math>1379.375 \div 300 = \\$2.75875 \approx \\$4.60</math></p> <p>Alternative solution <math>1379.375 - 200 = 1179.375</math> <math>1179.375 \div 300 = 3.93 \sim \\$4</math></p> <p>Possible assumption:</p> <ol style="list-style-type: none"><li>1) All 300 breakfast sets can be made without any loss of ingredient.</li><li>2) All 300 breakfast sets are sold at the minimum selling price during the carnival.</li><li>3) Did not include funding, as it is uncertain if it can be achieved.</li></ol>
--	---