

Visit

FREETESTPAPER.com

for more papers



Website: [freetestpaper.com](http://www.freetestpaper.com)



[Facebook.com/freetestpaper](https://www.facebook.com/freetestpaper)



[Twitter.com/freetestpaper](https://www.twitter.com/freetestpaper)



ANDERSON SECONDARY SCHOOL
Preliminary Examination 2017
Secondary Four Express & Five Normal
Academic



CANDIDATE NAME:

CLASS:

INDEX NUMBER:

BIOLOGY (SPA)

5158/01

Paper 1

18 August 2017

1 Hour

1130 – 1230h

Additional Materials: Multiple Choice Answer Sheet

READ THESE INSTRUCTIONS FIRST

Write in soft pencil.

Do not use staples, paper clips, highlighters, glue or correction fluid.

Write your name, Class and Index number on the Answer Sheet in the spaces provided unless this has been done for you.

There are **forty** questions on this paper. Answer **all** questions. For each question there are four possible answers **A, B, C** and **D**.

Choose the **one** you consider correct and record your choice in **soft pencil** on the separate Answer Sheet.

Read the instructions on the Answer Sheet very carefully.

Each correct answer will score one mark. A mark will not be deducted for a wrong answer. Any rough working should be done in this booklet.

This document consists of 15 printed pages

Setter : Lum Yoke Wah

SECTION A

Answer **all** the questions in the Multiple Choice Answer Sheet.

1 Which of the following are correct descriptions for a plant cell?

- (i) The nucleus contains genetic material.
- (ii) Photosynthesis occurs inside the chlorophyll.
- (iii) The cell wall is freely permeable to dissolved substances.

- | | | | |
|----------|--------------------|----------|---------------------|
| A | (i) and (ii) only | B | (ii) and (iii) only |
| C | (i) and (iii) only | D | (i), (ii) and (iii) |

2 Which of the following cells of a green leaf have chloroplasts?

- (i) guard cells
- (ii) mesophyll cells
- (iii) epidermal cells

- | | | | |
|----------|---------------------|----------|---------------------|
| A | (i) and (ii) only | B | (ii) only |
| C | (ii) and (iii) only | D | (i), (ii) and (iii) |

3 The diagram below shows three kinds of human cells:



All these cells _____.

- (i) carry out respiration
- (ii) contain genetic material
- (iii) can grow in size
- (iv) can undergo cell division

- | | | | |
|----------|---------------------|----------|--------------------------|
| A | (i) only | B | (i) and (ii) only |
| C | (ii) and (iii) only | D | (i), (iii) and (iv) only |

- 4 Which of the following structure can be found in a mesophyll cell, a root epidermal cell and a xylem vessel?

- A nucleus
 B cell membrane
 C cell wall
 D chloroplast

- 5 A sample of food mixed with water was tested to find out its contents. The results are shown in the table below:

| test | results |
|-----------------------|--------------------------------|
| Benedict's test | brick red precipitate formed |
| Iodine test | iodine solution remained brown |
| Ethanol emulsion test | white emulsion formed |
| Biuret test | violet solution formed |

What were present in the food sample?

- A amino acids, fats and reducing sugars
 B amino acids, fats and starch
 C reducing sugars, fats and proteins
 D starch, fats and proteins
- 6 The diagram below shows a neurone.

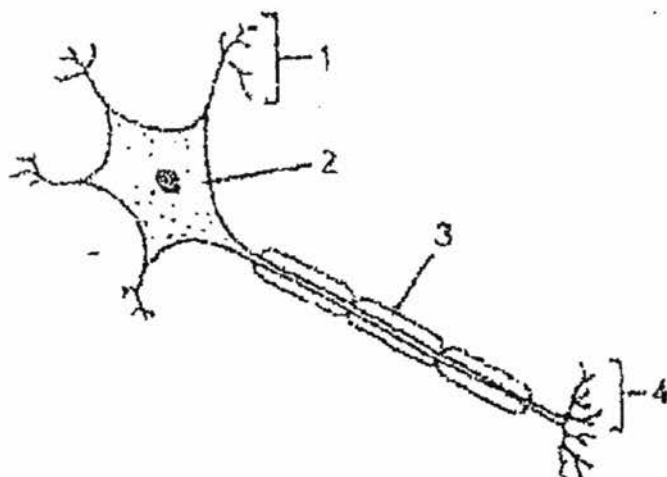

Which correctly identifies part 2 and the functions of parts 1 and 3?

| | 2 | function of 1 | function of 3 |
|---|-----------|--------------------|------------------------|
| A | axon | transmits impulses | speeds up transmission |
| B | cell body | insulation | receives impulses |
| C | cell body | receives impulses | insulation |
| D | dendron | receives impulses | speeds up transmission |

- 7 Four groups of potato strips have been immersed separately in different solutions (I to IV) for one hour. The following table shows the percentage change in mass of the potato strips:

| solution | Percentage change in mass / % |
|----------|-------------------------------|
| I | +8 |
| II | -6 |
| III | -3 |
| IV | 0 |

What conclusion can you draw from the results of this experiment?

- A Solution I has the highest water potential.
 B Solution II has a higher water potential than solution III.
 C Solution III has the highest water potential.
 D Solution IV is distilled water.
- 8 Which of the following processes is carried out by osmosis?
- A The formation of tissue fluid in the capillary network.
 B The absorption of water in the small intestine.
 C The upward transport of water in the xylem.
 D The formation of glomerular filtrate.
- 9 When the external temperature drops, the following changes may take place in the human body:

- (i) body temperature falls
 (ii) body temperature rises
 (iii) brain detects cooler blood
 (iv) shivering begins

In which order do they occur?

| | first \longrightarrow last | | | |
|---|------------------------------|-------|-------|------|
| A | (i) | (iii) | (iv) | (ii) |
| B | (i) | (iv) | (iii) | (ii) |
| C | (iii) | (ii) | (iv) | (i) |
| D | (iii) | (iv) | (ii) | (i) |

10 The diagram shows the flow of blood and dialysis fluid through a dialysis machine.

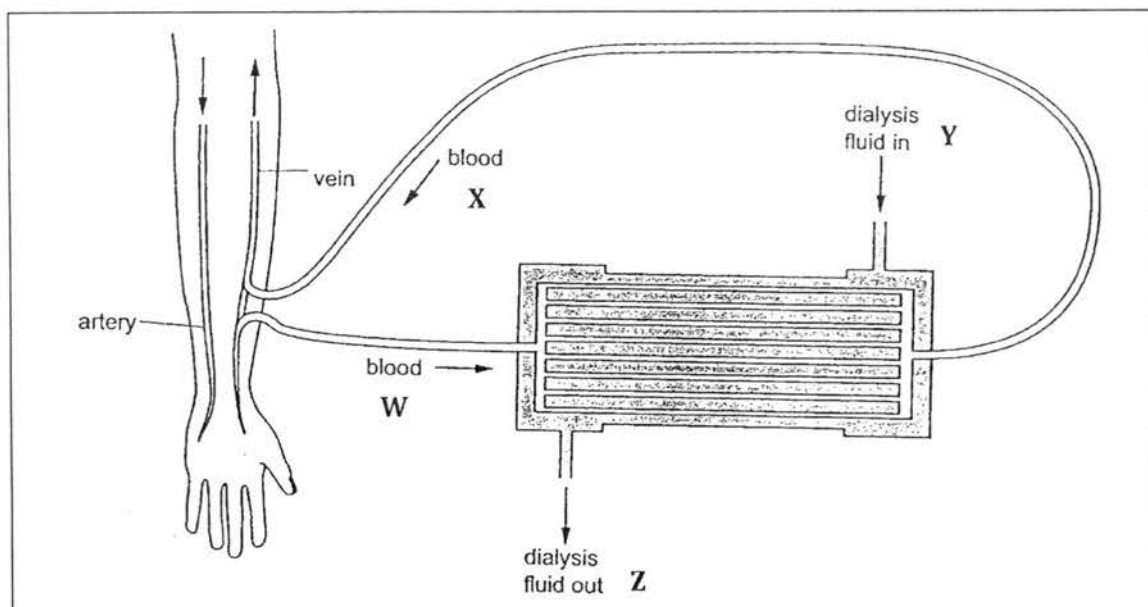

Where would the concentration of urea be the lowest or absent?

- A W and X
- B X and Y
- C W and Z
- D Y and Z

11 Which of the following processes in the human body **does not** require enzymes?

- (i) The formation of urea in the liver.
- (ii) The emulsification of oil in the duodenum.
- (iii) The neutralization of gastric juice by the pancreatic juice.

- A (i) only
- B (ii) only
- C (i) and (ii) only
- D (ii) and (iii) only

- 12 The diagram below shows the pathway of water movement from the soil into the root of a plant:

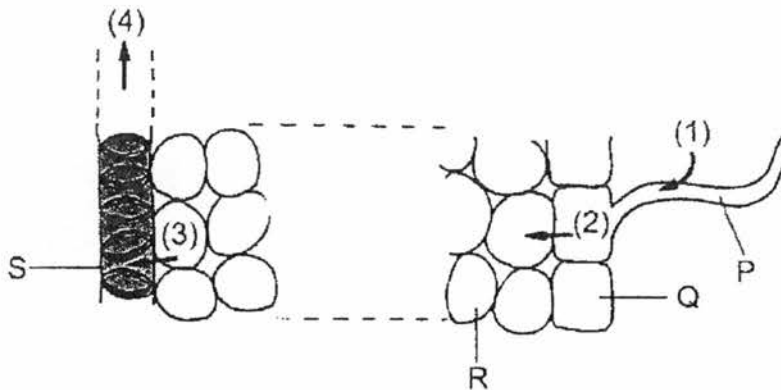

Osmosis occurs in _____.

- A (1) and (2) only
 B (1), (2) and (3) only
 C (2), (3) and (4) only
 D (1), (2), (3) and (4)
- 13 A patient has a large part of his colon removed in an operation. As a result, the patient could not _____.
- A eat solid food
 B eat fatty food
 C absorb amino acids efficiently
 D produce solid faeces
- 14 When bile juice is added to a sample of oil, it breaks down the oil to fat droplets. This is due to the effect of _____.
- A bile pigments
 B bile salts
 C lipase
 D water

Questions 15 and 16 refer to the diagram below, which shows the transverse section of a villus in the small intestine:

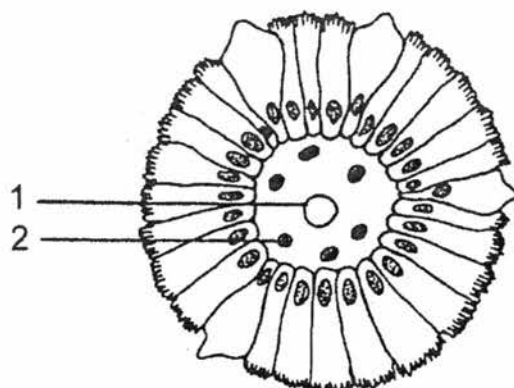

15 The food substances absorbed into structure 1 are mainly _____.

- | | | | |
|---|---------------|---|----------|
| A | fatty acids | B | vitamins |
| C | simple sugars | D | fats |

16 Food substances absorbed into structure 2 will first reach the _____.

- | | | | |
|---|-------|---|----------|
| A | liver | B | heart |
| C | lungs | D | pancreas |

Questions 17 and 18 refer to the graph below, which shows the rate of photosynthesis of a green plant when it is illuminated by lights of different colour:

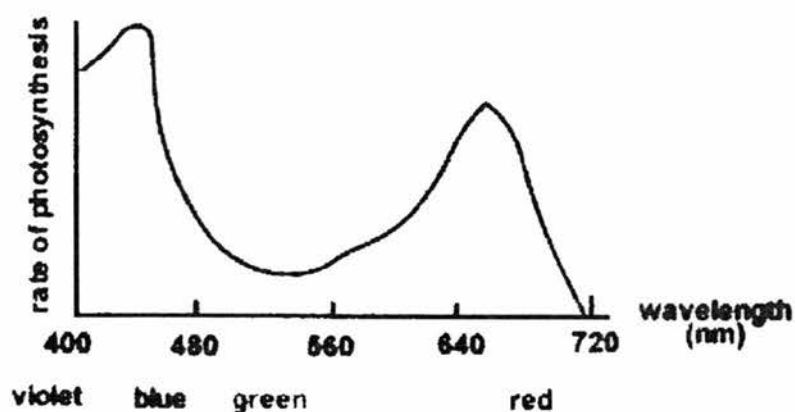

17 What colours of light are most effective for photosynthesis?

- | | | | |
|---|------------------|---|-----------------|
| A | yellow and green | B | yellow and blue |
| C | red and green | D | red and blue |

18 During photosynthesis, light energy is used to _____.

- A join glucose molecules into starch
 B break down water molecules
 C form glucose molecules
 D combine hydrogen and carbon dioxide

19 The statements are about how the liver deals with excess glucose:

- (i) It is converted to amino acids.
 (ii) It is converted to fats.
 (iii) It is deaminated to produce urea.
 (iv) It is stored as glycogen.

Which statements are correct?

- A (i) and (ii) only
 B (i), (ii) and (iii)
 C (ii) and (iv)
 D (iv) only

20 Refer to the photomicrograph of a section of a young root below:

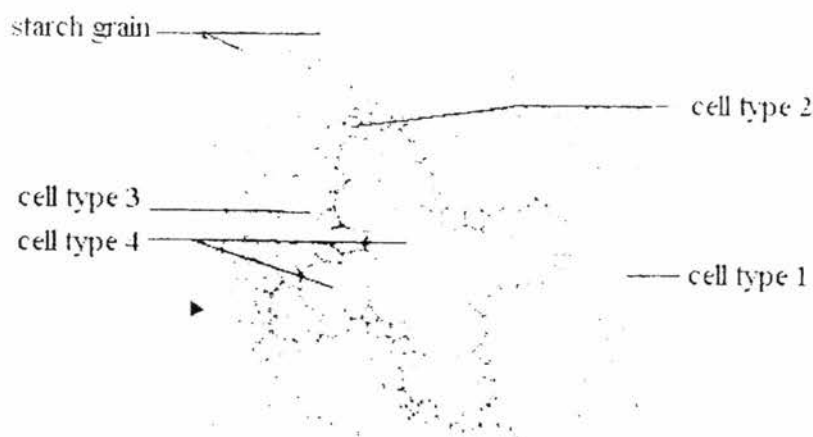

Which type of cells show the lowest rate of respiration?

- | | | | |
|---|-------------|---|-------------|
| A | cell type 1 | B | cell type 2 |
| C | cell type 3 | D | cell type 4 |

Questions 21 and 22 refer to the diagram below which shows a set-up used to measure the rate of water absorption and transpiration of a leafy shoot:

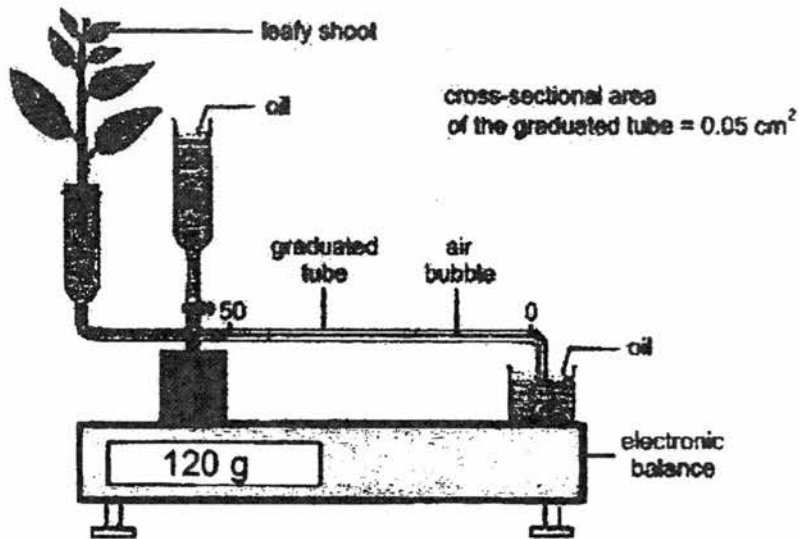

| | Initial reading | Reading after 30 min |
|-----------------------------|-----------------|----------------------|
| Position of air bubble (cm) | 2 | 12 |
| Weight of set-up (g) | 120.5 | 120.2 |

Note: 1 cm^3 water has a mass of 1 g.

21 What is the transpiration rate of the leafy shoot?

- A 0.3 g per hour
- B 0.4 g per hour
- C 0.5 g per hour
- D 0.6 g per hour

22 How much water is retained by the shoot in 30 minutes?

- A 0.2 g
- B 0.3 g
- C 0.4 g
- D 0.5 g

23 Urea is produced as an excretory substance in the human body in the _____.

- A urinary bladder
- B liver
- C kidney
- D rectum

24 Which of the following reactions occur in the skeletal muscle when a person is performing vigorous exercise?

- (i) glucose \rightarrow lactic acid
- (ii) glucose \rightarrow carbon dioxide
- (iii) glucose + oxygen \rightarrow carbon dioxide + water

- A (i) only
- B (iii) only
- C (i) and (iii) only
- D (i), (ii) and (iii)

25 When a person tries to focus on a distant object, which of the following changes occurs?

- | | <u>suspensory ligament</u> | <u>lens</u> |
|---|----------------------------|-------------|
| A | slacken | more convex |
| B | slacken | less convex |
| C | become taut | more convex |
| D | become taut | less convex |

26 The diagram below shows a nervous pathway in the human body:

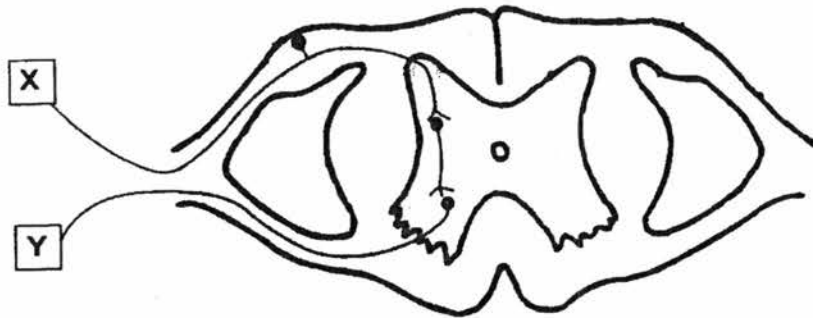

Structures X and Y could be:

- | | <u>X</u> | <u>Y</u> |
|---|----------------|----------------|
| A | leg muscle | skin of finger |
| B | pancreas | liver |
| C | retina | iris muscle |
| D | skin of finger | arm muscle |

27 Which of the following descriptions of insulin is **not** correct?

- A It is a protein.
- B It is secreted by an endocrine gland.
- C It is carried by the blood to the target organs.
- D It catalyses the conversion of glucose to glycogen.

28 Rice is a type of grass that has been grown by humans for about 5000 years. Over hundreds of years, farmers have improved the yield of rice crops. They kept grains from the highest yielding stalks to grow the next crop.

What is this farming practice?

- A genetic engineering
- B natural selection
- C out breeding
- D selective breeding

29 The graphs show the changes in the populations of predator and prey over a period of time.

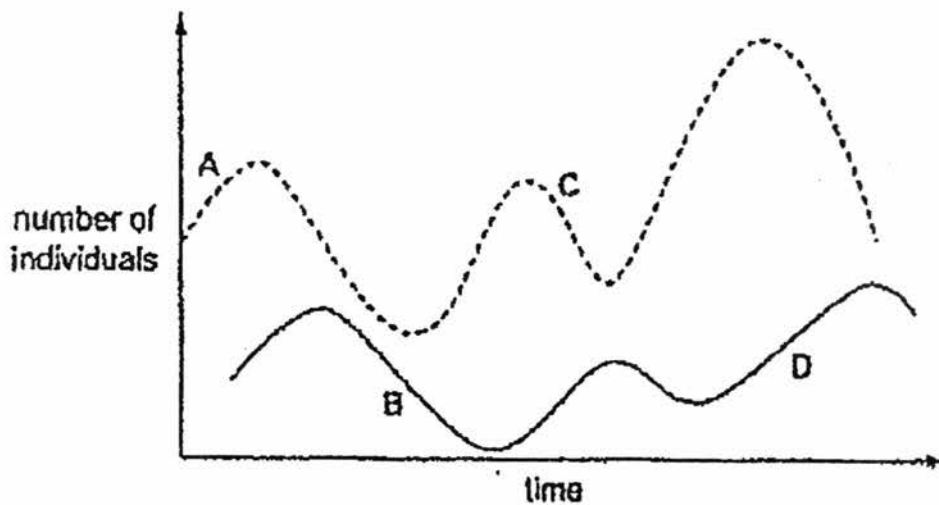

Which point on the graph shows a decrease in predator population?

30 The diagram shows how carbon circulates in nature.

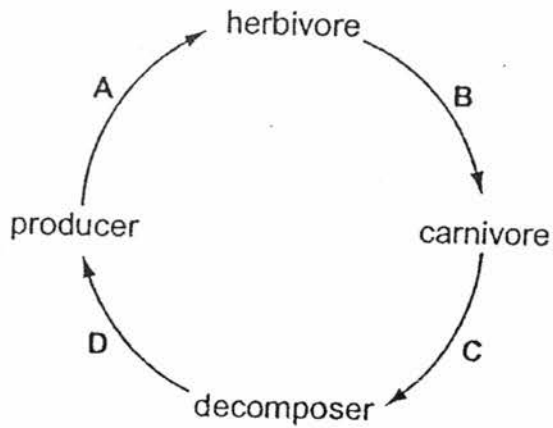

Through which stage does **most energy** flow?

Questions 31 and 32 refer to the diagram below, which shows the longitudinal section of a flower:

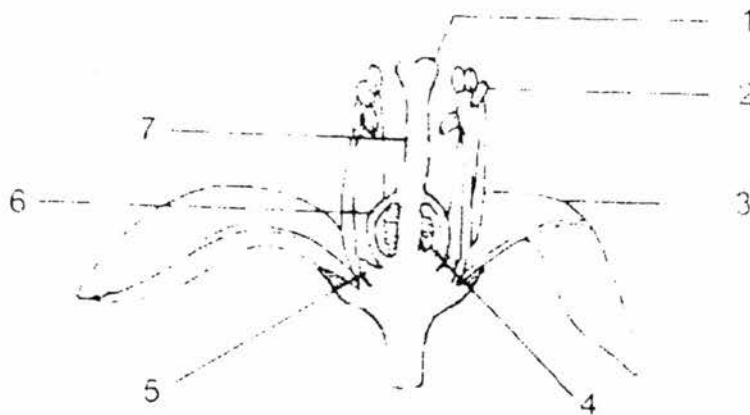

31 Meiosis occurs in _____.

- A 1 and 4
- B 1 and 6
- C 2 and 4
- D 2 and 6

36 If both of their parents have brown eyes, which of the following can be deduced?

- (i) Both parents are heterozygous for eye colour.
- (ii) Brown eye is dominant to blue eye.
- (iii) Both June and Jane are homozygous for eye colour.

- A (i) and (ii) only
- B (i) and (iii) only
- C (ii) and (iii) only
- D (i), (ii) and (iii)

37 In humans, a sperm differs from an ovum in that _____.

- A it contains less cytoplasm
- B it has a smaller nucleus
- C it has no sex chromosome
- D it contains a smaller number of chromosomes

38 In the human body, active cell division occurs in the following **except** the _____.

- A bone marrow
- B brain
- C testis
- D epidermis

39 All cells in our body are derived from the fertilized egg by cell division. Which of the following cells contain the same genetic material as the fertilized egg?

- (i) skin cells
 - (ii) brain cells
 - (iii) red blood cells
- A (i) and (ii) only
 - B (i) and (iii) only
 - C (ii) and (iii) only
 - D (i), (ii) and (iii)

40 A kind of cell division in the human body has the following main stages:

- (i) chromosomes separate
- (ii) chromosomes arrange in pairs
- (iii) DNA replicate

Which of the following is a correct sequence of the different stages?

- A (i), (ii), and (iii)
- B (i), (iii) and (ii)
- C (ii), (iii) and (i)
- D (iii), (ii) and (i)

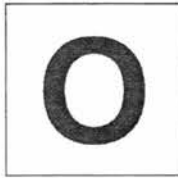

ANDERSON SECONDARY SCHOOL
Preliminary Examination 2017
Secondary Four Express & Five Normal
Academic



CANDIDATE NAME:

CLASS:

INDEX NUMBER:

BIOLOGY (SPA)

5158/02

Paper 2

24 August 2017

1 h 45 minutes

1040 – 1225h

Additional Materials: Multiple Choice Answer Sheet

READ THESE INSTRUCTIONS FIRST

Write your index number and name on all work you hand in.
Write in dark blue or black pen on both sides of the paper.
You may use a soft pencil for any diagrams, graphs.
Do not use staples, paper clips, highlighters, glue or correction fluid.

Section A

Answer **all** questions.

Write your answers in the spaces provided on the Question Paper

Section B

Answer **all** questions

Write your answers in the spaces provided on the Question Paper

The number of marks is given in brackets [] at the end of each question or part question.

This document consists of 20 printed pages

Setter : Lum Yoke Wah

SECTION AAnswer **all** the questions

Write your answers in the spaces provided.

- 1 The table shows the pressure changes in the left side of the heart during one cardiac cycle.

| time /s | blood pressure / kPA | |
|---------|----------------------|----------------|
| | left atrium | left ventricle |
| 0.0 | 0.7 | 0.3 |
| 0.1 | 1.0 | 2.0 |
| 0.2 | 0.1 | 12.5 |
| 0.3 | 0.2 | 15.3 |
| 0.4 | 1.0 | 4.5 |
| 0.5 | 0.5 | 1.0 |
| 0.6 | 0.6 | 0.3 |
| 0.7 | 0.7 | 0.3 |

- (a) When is the valve between the atrium and the ventricle closed?
Explain your answer.

Between:s tos.

Explanation:

.....

[2]

- (b) The maximum pressure in the ventricle is much higher than that in the atrium.
State what causes this.

.....

[2]

(c) Use the information in the table to calculate the heart rate in beats per minute.

.....
.....
.....[1]

[Total: 5]

2 The diagram shows a unicellular organism called Chlamydomonas.

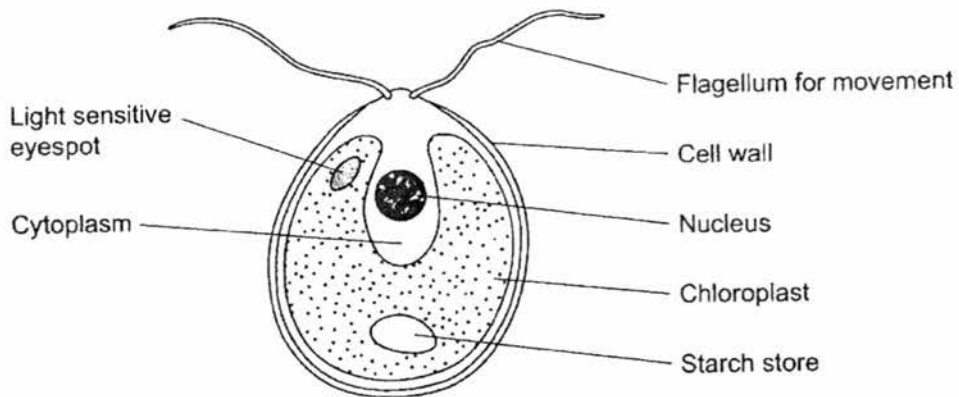

(a) Name **two** structures shown in the diagram that are present in plant cells but are not present in animal cells.

.....
.....[2]

(b) Chlamydomonas lives in freshwater ponds. Use your knowledge of osmosis to suggest an advantage of using starch as a carbohydrate store.

.....
.....
.....
.....[1]

(c) *Chlamydomonas* has adaptations that help it to maintain a high rate of photosynthesis. Use information in the diagram to explain what these adaptations are.

.....

.....

.....

.....

.....[2]

[Total: 5]

3 The graph shows the effect of substrate concentration on the rate of an enzyme-controlled reaction.

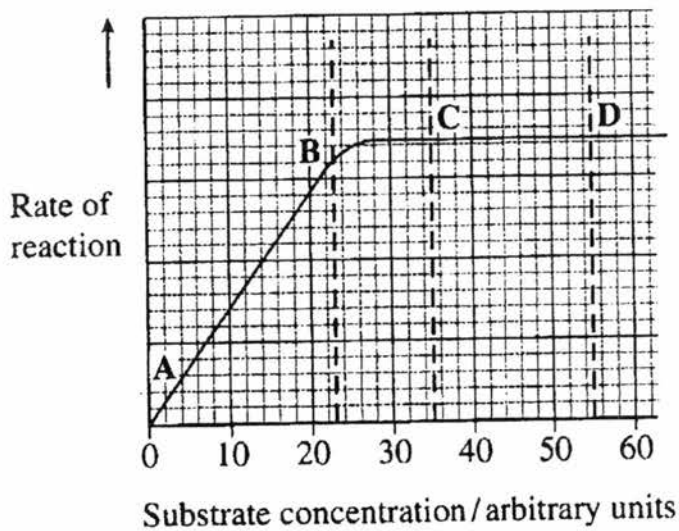

(a) Using information from the graph, describe the effect of substrate concentration on the rate of this enzyme-controlled reaction.

.....

.....

.....

.....

.....[2]

(b) Explain with evidence from the graph what limits the rate of reaction between points A and B?

.....

[1]

(c) Suggest a reason for the shape of the curve between points C and D.

.....

[1]

(d) Sketch a curve on the graph to show the rate of this reaction when the temperature is increased to optimum temperature. [1]

[Total: 5]

4 The diagram shows an epithelial cell from the small intestine which is involved in the absorption of nutrients after digestion:

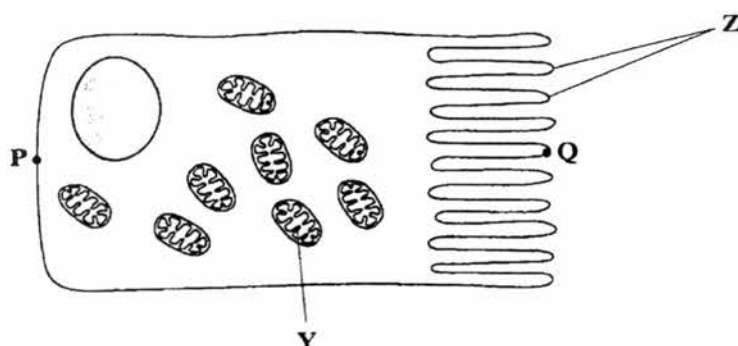

(a) Name the organelle Y.

Y:[1]

(b) There are large numbers of organelle Y in this cell. Explain the reason for this.

.....

.....

.....

.....[2]

(c) Celiac disease is a disease of the human digestive system which results in less of the structures Z. Although people with celiac disease can digest proteins, they have low concentrations of amino acids in their blood. Identify Z and explain why they have low concentrations of amino acids in their blood.

.....

.....

.....

.....[2]

[Total: 5]

5 The diagram shows some of the large blood vessels in a mammal:

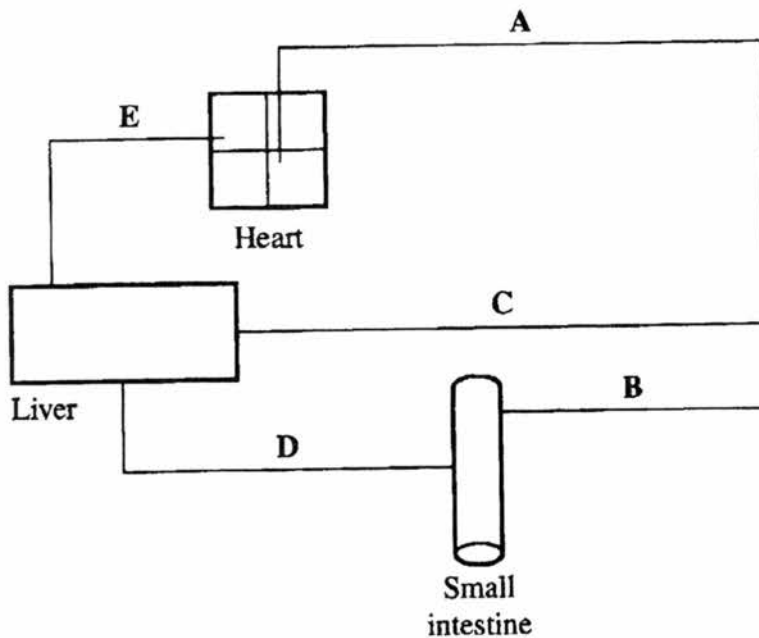

(a) Add arrows to the diagram to show the direction of blood flow in each of the blood vessels A to E.

[1]

(b) Which of the blood vessels **A** to **E** is the hepatic portal vein?

.....[1]

(c) Which of the blood vessels **A** to **E** contains blood at the lowest pressure?

.....[1]

(d) Complete the table to show two differences between the structure of vessel **C** and the structure of vessel **E**. [2]

| structural feature | vessel C | vessel E |
|--------------------|----------|----------|
| | | |
| | | |

[Total: 5]

6 The diagram shows mitosis in a cell cycle:

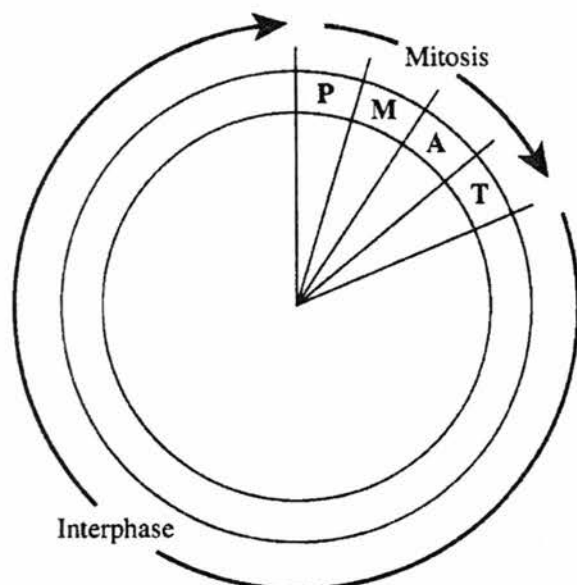

Key

- P** prophase
- M** metaphase
- A** anaphase
- T** telophase

- (a) The table shows the number of chromosomes and the mass of DNA in different nuclei. All nuclei come from the same animal. Complete this table. [2]

| nucleus | number of chromosomes | mass of DNA / arbitrary units |
|-------------------------|-----------------------|-------------------------------|
| at prophase of mitosis | 26 | 60 |
| at telophase of mitosis | | |
| from a sperm cell | | |

- (b) A protein called p53 stops the cell cycle. Uncontrolled cell division can cause cancer to develop. Suggest how mutation can cause cancer.

.....

.....

.....

.....

.....

.....

.....

.....[2]

- (c) New drugs are developed to treat cancer. At what phase in the cell cycle would each of the following drugs act?

(i) A drug that prevents DNA replication.

.....[1]

(ii) A drug that prevents spindle fibres shortening.

.....[1]

[Total: 6]

7 The diagram shows part of a DNA molecule.

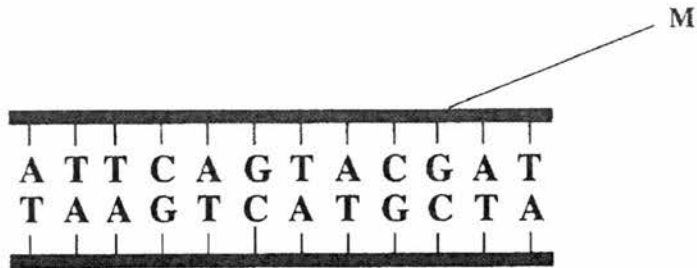

(a) Name the **two** components of the part of the DNA molecule labeled **M**.

.....[2]

(b) Scientists calculated the percentage of different bases in the DNA from a species of bacterium. They found that 14% of the bases were guanine. What percentage of the bases in this species of bacterium was adenine? Explain your answer.

.....
.....
.....[2]

[Total: 4]

8 A breeder crossed a black male cat with a black female cat. The female cat produced 8 black kittens and 4 white kittens.

(a) Explain using the observation why the allele for white fur is most likely recessive.

.....
.....
.....[1]

(b) Draw a genetic diagram and predict the likely ratio of colours of kittens born to a cross between this **black** male and a white female. [5]

Ratio of black fur : white fur is[1]

[Total: 7]

(ii) If the lake water contains a trace amount of DDT, explain which organism may have the highest concentration of DDT in its body?

.....

.....

.....

.....

.....

.....

.....[3]

[Total: 8]

Name: _____ () Class: _____

SECTION BAnswer **three** questions.Question 12 is in the form of an **Either/Or**
Only one part should be answered.

Write your answers in the spaces provided.

- 10** Students investigated the effect of different concentrations of sodium chloride solution on discs cut from an apple. They weighed each disc and then put one disc into each of a range of sodium chloride solutions of different concentrations. They left the discs in the solutions for 24 hours and then weighed them again. Their results are shown in the table:

| concentration of sodium chloride solution / mol dm ⁻³ | mass of disc at start / g | mass of disc at end / g | ratio of mass at start to mass at end |
|--|---------------------------|-------------------------|---------------------------------------|
| 0.00 | 16.1 | 17.2 | 0.94 |
| 0.15 | 19.1 | 20.2 | 0.95 |
| 0.30 | 24.3 | 23.2 | 1.05 |
| 0.45 | 20.2 | 18.7 | 1.08 |
| 0.60 | 23.7 | 21.9 | |
| 0.75 | 14.9 | 13.7 | 1.09 |

- (a) Calculate the ratio of the mass at the start to the mass at the end for the disc placed in the 0.60 mol dm⁻³ sodium chloride solution and fill in the table. [1]

- (b) The students gave their results as a ratio. List 2 advantages of giving the results as a ratio?

1.

2. [2]

(c) Plot this data on the grid provided with concentration of sodium chloride solution on the x-axis and ratio of mass at start to mass at end on the y-axis. [4]

(d) The students were advised that they could improve the reliability of their results by taking additional readings at the same concentrations of sodium chloride. List 2 advantages of doing so.

1.

2.[2]

(e) From the graph plotted, find the concentration of the sodium chloride solution that has the same water potential as the apple tissue.

.....[1]

[Total: 10]

12 Either

The graph shows changes in the volume of air in a person's lungs during breathing:

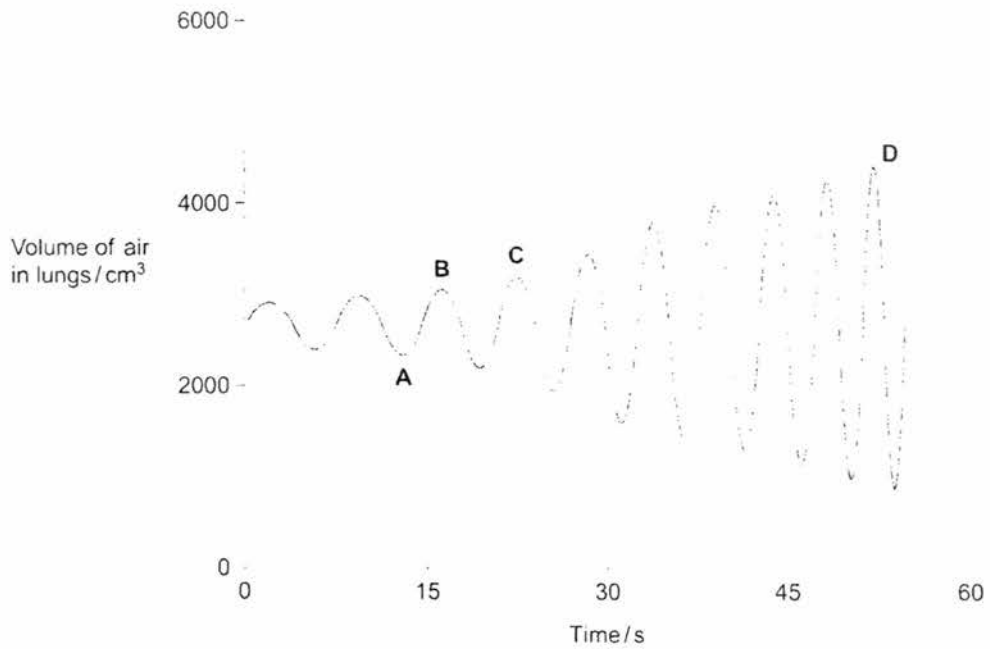

The person was breathing in between times **A** and **B** on the graph.

- (a) Explain how the graph shows that the person was breathing in between times **A** and **B** and describe what happens to the diaphragm between times **A** and **B**.

.....

.....

.....

.....

.....

.....

.....[2]

(b) The person's breathing changed between times **C** and **D**. Describe how the graph shows the changes in his breathing, and suggest one cause of this change in breathing

.....
.....
.....
.....
.....[3]

(c) Describe and explain how the lungs are adapted to allow rapid exchange of oxygen between air in the alveoli and the blood in the capillaries around them.

.....
.....
.....
.....
.....
.....
.....
.....
.....
.....
.....
.....
.....
.....
.....
.....
.....
.....
.....
.....
.....
.....[4]

[Total: 10]

(b) Why does the ingestion of alcohol increase the volume of urine?

.....
.....
.....
.....
.....
.....[2]

(c) How are excretory products removed from the blood during kidney dialysis without removing glucose?

.....
.....
.....
.....
.....
.....
.....
.....
.....[3]

[Total: 10]

Anderson Secondary School
2017 Secondary 4 Express Prelim
Biology 5158 Mark Scheme

| | | | | | | | | | |
|-----|-----|-----|-----|-----|-----|-----|-----|-----|-----|
| A1 | A2 | A3 | A4 | A5 | A6 | A7 | A8 | A9 | A10 |
| C | A | A | C | C | C | A | B | A | B |
| A11 | A12 | A13 | A14 | A15 | A16 | A17 | A18 | A19 | A20 |
| D | B | D | B | D | A | D | B | C | D |
| A21 | A22 | A23 | A24 | A25 | A26 | A27 | A28 | A29 | A30 |
| D | A | B | C | D | D | D | D | B | A |
| A31 | A32 | A33 | A34 | A35 | A36 | A37 | A38 | A39 | A40 |
| C | D | D | B | B | D | A | B | A | D |

| Question | Solution | Marks | Comments |
|----------|---|-------|--|
| 1 (a) | 0.1s and 0.5s [1] Pressure in ventricle higher than pressure in atrium [1] | [2] | |
| (b) | Ventricle has thicker wall / is much muscular than atrium [1] So ventricle <u>contractions</u> are stronger / harder / create higher pressure [1] | [2] | R: never say ventricle contract to generate higher pressure |
| (c) | $60 / 0.7 = 85.7 = 86$ heart beats per min [1] [R: decimal places] | [1] | R: decimals since cannot have fraction of heartbeat |
| 2 (a) | Any 2: Cell wall / starch store / chloroplast [2] | [2] | |
| (b) | Starch is <u>insoluble</u> + Starch does not affect <u>water potential</u> and affect water entry by osmosis | [1] | R: starch lower water potential or increase water potential |
| (c) | Any 2: Light sensitive eyespot detects light [1] Flagellum enables movement towards light [1] Has one large cup-shaped chloroplast contains <u>chlorophyll</u> absorbs light for photosynthesis [1] | [2] | R: statement not complete, does not show purpose. R: many chloroplasts R: no mention of chlorophyll |
| 3 (a) | When the substrate concentration increases from 0 to <u>27 / 28 arbitrary units</u> , the rate of reaction increases [1]. The rate of reaction plateaus / become constant at beyond substrate concentration of 27 / 28 units [1] | [2] | R: no mention of values R: rate of reaction increases linearly / proportionally from 0 to 26 arbitrary units of substrate concentration |
| (b) | Substrate concentration is limiting because when substrate concentration increases from | [1] | |

| Question | Solution | Marks | Comments | | | | | | | | | | | | | | | | | | | | | |
|-----------------------|---|--------------------|---------------------------------------|----------|--------|--|--|--------|--------|---------|--------------------|---------|---------|--------|------|------|-----------------------|------|------|-------|--------|------|-----|--------------------------------------|
| | 0 to 23 arbitrary units, rate of reaction also increases [1] | | | | | | | | | | | | | | | | | | | | | | | |
| (c) | All active sites are occupied / saturated with substrates/ maximum number of enzyme-substrate complexes formed [1] | [1] | R: enzymes used up | | | | | | | | | | | | | | | | | | | | | |
| (d) | Curve is steeper and plateaus at a lower substrate concentration (it must also start at zero). | [1] | R: curve plateaus lower than original | | | | | | | | | | | | | | | | | | | | | |
| 4 (a) | mitochondrion | [1] | | | | | | | | | | | | | | | | | | | | | | |
| (b) | Mitochondrion is the site of aerobic <u>respiration</u> [1], to <u>release energy</u> to help to absorb the <u>glucose / amino acids / fatty acids & glycerol</u> (must list any 2 nutrients) against concentration gradient by <u>active transport from the small intestine into the bloodstream</u> . [1] | [2] | R: produce energy | | | | | | | | | | | | | | | | | | | | | |
| (c) | Z are <u>villi</u> [1] R:villus When villi are destroyed there will be <u>reduced surface area</u> for absorption, reducing the amount of amino acids absorbed from the small intestine [1] | [2] | R: no absorption | | | | | | | | | | | | | | | | | | | | | |
| 5 (a) | Arrow for A away from heart; arrows for C and B towards the organs; arrow for D towards the liver; arrow for E towards the heart [1] | [1] | | | | | | | | | | | | | | | | | | | | | | |
| (b) | D | [1] | | | | | | | | | | | | | | | | | | | | | | |
| (c) | E | [1] | | | | | | | | | | | | | | | | | | | | | | |
| (d) | <table border="1"> <thead> <tr> <th>structural feature</th> <th>vessel C</th> <th>vessel E</th> </tr> </thead> <tbody> <tr> <td>Any 2:</td> <td></td> <td></td> </tr> <tr> <td>valves</td> <td>absent</td> <td>present</td> </tr> <tr> <td>Thickness of walls</td> <td>thicker</td> <td>thinner</td> </tr> <tr> <td>muscle</td> <td>more</td> <td>less</td> </tr> <tr> <td>Elastic fibers/tissue</td> <td>more</td> <td>less</td> </tr> <tr> <td>lumen</td> <td>narrow</td> <td>wide</td> </tr> </tbody> </table> | structural feature | vessel C | vessel E | Any 2: | | | valves | absent | present | Thickness of walls | thicker | thinner | muscle | more | less | Elastic fibers/tissue | more | less | lumen | narrow | wide | [2] | R: vessel C – thick, vessel E - thin |
| structural feature | vessel C | vessel E | | | | | | | | | | | | | | | | | | | | | | |
| Any 2: | | | | | | | | | | | | | | | | | | | | | | | | |
| valves | absent | present | | | | | | | | | | | | | | | | | | | | | | |
| Thickness of walls | thicker | thinner | | | | | | | | | | | | | | | | | | | | | | |
| muscle | more | less | | | | | | | | | | | | | | | | | | | | | | |
| Elastic fibers/tissue | more | less | | | | | | | | | | | | | | | | | | | | | | |
| lumen | narrow | wide | | | | | | | | | | | | | | | | | | | | | | |
| 6 (a) | For telophase: 26, 30 [1] For sperm cell: 13, 15 [1] | [2] | | | | | | | | | | | | | | | | | | | | | | |
| (b) | Mutation cause a change in the DNA code that produces p53 [1] Protein p53 is not made [1] | [2] | | | | | | | | | | | | | | | | | | | | | | |
| (c) (i) | interphase | [1] | | | | | | | | | | | | | | | | | | | | | | |
| (c) (ii) | anaphase | [1] | | | | | | | | | | | | | | | | | | | | | | |
| 7 (a) | Phosphate, deoxyribose | [2] | | | | | | | | | | | | | | | | | | | | | | |
| (b) | 36% of the bases is A [1] 14% of bases is G, so 14% of bases is C since there are <u>complementary base pairs</u> C-G, so 78% of the bases are for the A-G base pairs [1] | [2] | | | | | | | | | | | | | | | | | | | | | | |
| 8 (a) | Since both parents are black yet they can | [1] | | | | | | | | | | | | | | | | | | | | | | |

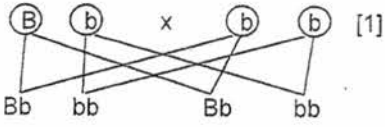
| Question | Solution | Marks | Comments |
|----------|---|-------|---|
| | produce white kittens, it means the parents are <u>heterozygous</u> black, and have the recessive white allele. Since the white allele is not expressed in the parent, it is recessive. | | |
| (b) | <p>Let B represent dominant allele for black fur. Let b represent recessive allele for white fur. [1] Parental phenotype: black male x white female Parental genotype: Bb x bb [1]</p> <p>Gametes:  [1]</p> <p>F1 generation genotype = 2 Bb : 2 bb [1] F1 generation phenotype = 2 black fur : 2 white fur [1]</p> <p>Ratio of black fur : white fur is 1:1 [1]</p> | [6] | R: no proper labels |
| 9 (a) | <p>The <u>organic wastes</u> in sewage are a good <u>source of food for bacteria</u>. [1] Bacteria grow and multiply rapidly, using up the oxygen in the water so oxygen concentration at P is low / lower [1] Further downstream, at Q is far from the pollution point, there is <u>less organic matter, less bacteria</u> so the oxygen concentration is <u>higher than at P</u>. [1]</p> | [3] | <p>R: eutrophication, growth of algae (no marks given if mention algae since it is organic waste) R: decomposition uses oxygen (should be bacterial respiration)</p> |
| (b) (i) | Shrimp population decrease will cause wild duck population to decrease since shrimp is a food source for wild duck [1]. As wild duck also feed on fish, the wild duck population is also indirectly caused to reduce by the reduction in the fish population which is caused by the reduction on the shrimp population [1] | [2] | |
| (b) (ii) | <p>DDT is <u>non-biodegradable</u> and when consumed is <u>not excreted</u> [1] It is stored in the <u>fatty tissues</u> of the shrimp and fishes [1] As it goes up the food chain it will build up as the higher level consumers consume more and it reaches highest concentration in the <u>wild ducks</u> due to <u>bioaccumulation</u> [1].</p> | [3] | R: bioaccumulation occurs from one trophic level to the next; should be bioamplification. Top predator is bioaccumulation. |
| 10 (a) | 1.08 | [1] | |
| (b) | <p>Allows comparison / shows proportional change [1] Allows discs with different starting masses [1] Easily determine if there has been a gain or loss in mass [1]</p> | [2] | R: Easier to observe trend |
| (c) | <p>Both axes labelled correctly with units [1] Appropriate scale that allows > 50% of graph paper used for both axes [1] Points accurately plotted, allow 1 error [1]. Best fit graph drawn [1]</p> | [4] | R: Ratio of mass |

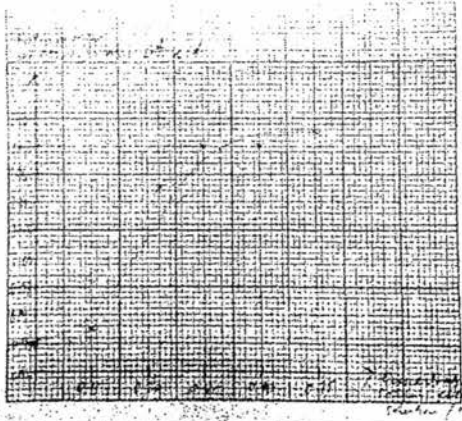
| Question | Solution | Marks | Comments |
|----------|---|-------|---|
| |  | | |
| (d) | <p>Allows anomalies to be identified / allows effect of anomalies to be reduced / effect of drastic variation in data to be minimised [1] A more reliable average/mean can be calculated <u>without the anomalous data</u> [1]</p> | [2] | R: accurate (should be reliable) |
| (e) | <p>Reading where ratio = 1, so concentration of sodium chloride solution is 0.24 mol dm^{-3} (take from student's graph)</p> | [1] | |
| 11 (a) | <p>W: erector muscle X: blood capillaries [R: blood capillary] Y: sweat gland</p> | [2] | <p>3 correct = 2 marks 2 correct = 1 mark 1 correct = no mark</p> |
| (b) | <p>- Rise in body temperature is the stimulus and trigger the <u>hypothalamus</u> (is the receptor) [1] - Hypothalamus is stimulated and sends nerve impulses to relevant body parts. <u>Skin arterioles vasodilate</u> and <u>shunt vessels constrict</u> [1] - More blood flows to capillaries in skin, greater heat loss via radiation, conduction & convection [1] [A: radiation only] - <u>Sweat glands</u> become <u>more active</u> and secrete more sweat. Heat loss via latent heat of vaporization when sweat evaporates [1]</p> | [4] | R: lost of latent heat of vaporisation |
| (c) | <p>- Blood <u>water potential rises</u> and trigger the hypothalamus to cause the pituitary gland to release <u>less Anti-diuretic hormone (ADH)</u>. <u>Less water reabsorbed</u> at the <u>collecting duct</u> as it is less permeable to water, so more water lost resulting in large volume of urine [1] - excess salts also excreted from the kidneys resulting in more concentrated urine/less selective reabsorption of mineral salts [1]</p> | [2] | |
| (d) | <p>Blood glucose level <u>drops below set point</u>. Stimulate the <u>Islets of Langerhans</u> to release <u>more glucagon</u> which is transported by blood to liver and muscles. Glucagon converts the stored glycogen to glucose [1]. Blood glucose level rises until set point. When blood glucose concentration returns to set point it</p> | [2] | |

| Question | Solution | Marks | Comments |
|--------------|--|--------------------|---|
| | serves as a feedback for the Islets of Langerhans to release normal amounts of glucagon [1] | | |
| 12 Either | (a) Volume of air in the lungs increased indicating that he is breathing in [1]. Diaphragm contracts [1] And flattens / moves down [1] | [3] | IB: describe about intercostal muscles which is not asked for in question |
| | (b) Breathing rate increases / more breaths per min between C and D [1] Volume of air inhaled per breath increases / deeper breaths [1] One cause – could be started running / exercising/increased adrenaline level in blood [1] | [2] [1] | |
| | (c) - alveoli are spherical in shape and present in large quantities, providing a <u>huge surface area</u> for <u>faster diffusion of oxygen</u> into the blood [1] -The walls of the alveoli are <u>one-cell thick</u> , resulting in a small distance for diffusion for <u>faster rate of diffusion</u> of gases through it [1] - inner alveolar surface are covered with a thin film of moisture/water allowing the <u>dissolving of oxygen</u> and the subsequent <u>rapid diffusion</u> in solution [1] - alveoli are well-supplied with blood capillaries which transport away diffused oxygen so as to maintain a steep concentration gradient for diffusion of oxygen into the blood [1] | [4] | R: alveoli is one cell thick |
| 12 Or | (a) -Urea molecule travels to a branch of the renal artery and reaches the <u>glomerulus</u> [1] - <u>high hydrostatic pressure</u> created by <u>the afferent arteriole having a wider lumen than the efferent arteriole</u> [1] forces the urea molecule through the partially permeable basement membrane into the <u>renal capsule / Bowman's capsule</u> by <u>ultrafiltration</u> [1] -travels to the proximal convoluted tubule, Loop of Henle distal convoluted tubule [1] and collecting duct without being selectively reabsorbed [1] - reaches the <u>renal pelvis</u> and into the <u>ureter</u> [1] - stored in the <u>urinary bladder</u> and travels out of the body via the <u>urethra</u> during urination [1] | [5 max.] | |
| | (b) Alcohol inhibits the secretion of anti-diuretic hormone / less ADH by the pituitary gland [1] Less ADH leads to less water being reabsorbed at the <u>collecting duct</u> so more urine produced [1] | [2] | |
| | (c) -Dialysis fluid <u>does not contain</u> metabolic waste products so a concentration <u>gradient exists</u> for urea, uric acid and creatinine, excess water and mineral salts to diffuse out of the tubing into the dialysis fluid [compulsory, 1] -Dialysis fluid contains the <u>same concentration of glucose</u> as the blood so that glucose do not | [3] | |

| Question | Solution | Marks | Comments |
|----------|---|-------|----------|
| | <p>diffuse out of the patient's blood into the dialysis fluid. [compulsory,1]</p> <p>Any 1:</p> <ul style="list-style-type: none"> -The direction of blood flow is opposite to the flow of the dialysis fluid. This maintains the concentration gradient for the removal of waste products [1] -The partially permeable tubing is narrow, long and coiled to increase the surface area to volume ratio. This speeds up the rate of diffusion of waste substances from the blood into the dialysis fluid [1] | | |
| | | | |
| | | | |
| | | | |
| | | | |