

Visit

FREETESTPAPER.com

for more papers



Website: [freetestpaper.com](http://www.freetestpaper.com)



[Facebook.com/freetestpaper](https://www.facebook.com/freetestpaper)



[Twitter.com/freetestpaper](https://www.twitter.com/freetestpaper)

	Class	Register Number
Name:		

*DUNEARN SECONDARY SCHOOL DUNEARN SECONDARY SCHOOL DUNEARN SECONDARY SCHOOL DUNEARN SECONDARY SCHOOL DUNEARN SECONDARY SCHOOL
DUNEARN SECONDARY SCHOOL DUNEARN SECONDARY SCHOOL DUNEARN SECONDARY SCHOOL DUNEARN SECONDARY SCHOOL DUNEARN SECONDARY SCHOOL
DUNEARN SECONDARY SCHOOL DUNEARN SECONDARY SCHOOL DUNEARN SECONDARY SCHOOL DUNEARN SECONDARY SCHOOL DUNEARN SECONDARY SCHOOL
DUNEARN SECONDARY SCHOOL DUNEARN SECONDARY SCHOOL DUNEARN SECONDARY SCHOOL DUNEARN SECONDARY SCHOOL DUNEARN SECONDARY SCHOOL*



**DUNEARN SECONDARY SCHOOL
Preliminary Examination 2020**

**Biology 6093
Paper 1
Secondary 4 Express**

17 Sep 2020 (Thursday)

1045 - 1145

1 Hour

INSTRUCTIONS TO CANDIDATES

Write your name, class and register number in the spaces at the top of this page.

There are forty questions in this paper. Answer **ALL** questions. For each question, there are 4 possible answers, **A, B, C** and **D**. Choose the **one** you consider correct and shade in the OTAS provided.

Setter: Mr Ng Hock Ping

This question paper consists of **19** printed pages including the cover page.

- 1 The diagram shows a cell from a plant leaf and a cell from an animal's skin. Which part will stain blue-black with iodine solution?

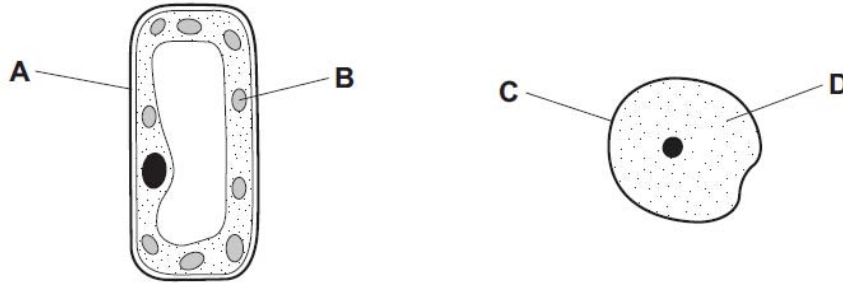

- 2 Which statement about cells or tissues is correct?

- A Xylem vessels have ciliated cells.
- B Muscle cells are biconcave.
- C Cells in the respiratory tract are long and thin.
- D Red blood cells have no nucleus.

- 3 The diagram shows a plant cell after being placed in a solution for an hour.

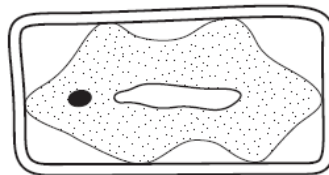

What provides the explanation for the appearance of this cell?

- A The cell has gained water and is turgid.
 - B The cell has gained water and is no longer turgid.
 - C The cell has lost water and is turgid.
 - D The cell has lost water and is no longer turgid.
- 4 The diagram shows an experiment on osmosis. Which arrow shows the direction of osmosis at the **start** of the experiment?

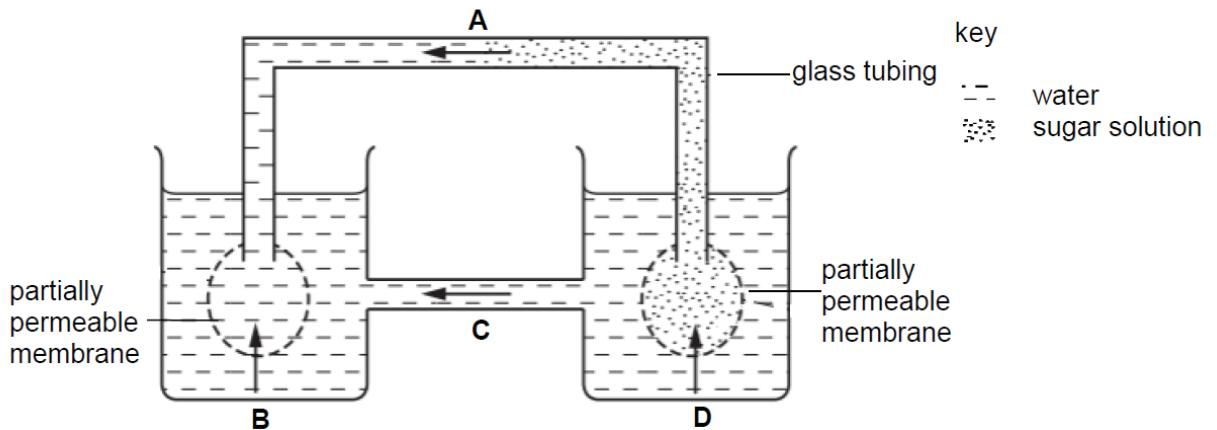

- 5 The table shows the rates of absorption of two different sugars, arabinose and glucose, in living and dead intestines. The concentrations of the sugars inside the intestines were the same in each case.

	rate of absorption (arbitrary units)	
	glucose	arabinose
living intestine	125	15
dead intestine	16	16

What are the main methods of absorption of arabinose and glucose in living intestine?

	glucose	arabinose
A	active transport	active transport
B	active transport	diffusion
C	diffusion	active transport
D	diffusion	diffusion

- 6 The table shows the results of some experiments performed by a student.

experiment	contents of the test-tube	temperature of water bath / °C	food test carried out 20 mins after the start of the experiment	
			iodine test	Benedict's test
1	5 ml X + 2 ml distilled water	37	blue-black	blue
2	5 ml X + 1 ml Y + 1 ml distilled water	37	blue-black	blue
3	5 ml X + 1 ml Y + 1 ml NaOH	37	brown	brick-red precipitate
4	5 ml X + 1 ml Y (boiled) + 1 ml distilled water	37	blue-black	blue

Which row correctly identifies substances X, Y and the product of the reaction?

	X	Y	product of the reaction
A	starch	gastric juice	reducing sugar
B	starch	pancreatic juice	reducing sugar
C	glycogen	saliva	non-reducing sugar
D	glycogen	saliva	reducing sugar

7 Which of the following comparisons about the nutrients is correct?

	elements that may be found in the nutrients			
	starch	glycogen	proteins	fats
A	carbon, hydrogen and oxygen	carbon, hydrogen and oxygen	carbon, hydrogen, oxygen, nitrogen and sulfur	carbon, hydrogen and oxygen
B	carbon, hydrogen and oxygen	carbon, hydrogen and oxygen	carbon, hydrogen, oxygen and nitrogen	carbon, hydrogen, oxygen and magnesium
C	carbon, hydrogen and oxygen	carbon, hydrogen, oxygen and magnesium	carbon, hydrogen, oxygen, nitrogen and sulfur	carbon, hydrogen and oxygen
D	carbon, hydrogen, oxygen and nitrogen	carbon, hydrogen and oxygen	carbon, hydrogen and oxygen	carbon, hydrogen, oxygen and nitrogen

8 The diagram illustrates the 'lock and key' hypothesis of an enzymatic reaction.

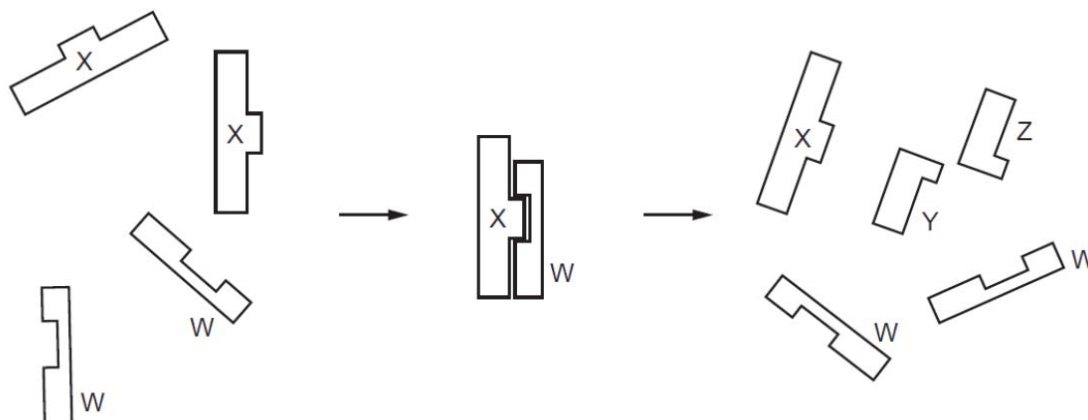

What are the enzyme, product and substrate in this reaction?

	enzyme	substrate	product
A	W	X	Y and Z
B	W	Y and Z	X
C	X	W	Y and Z
D	X	Y and Z	W

- 9 Diastase is a plant amylase. The diagram below shows a petri dish of starch agar set up to investigate the effect of pH on the activity of diastase. After 24 hours at room temperature, the plate was flooded with iodine solution.

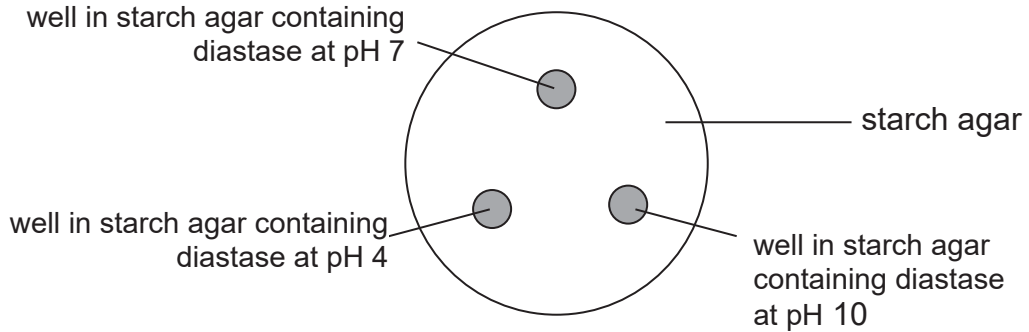

Which of the following shows that diastase works best at pH 7?

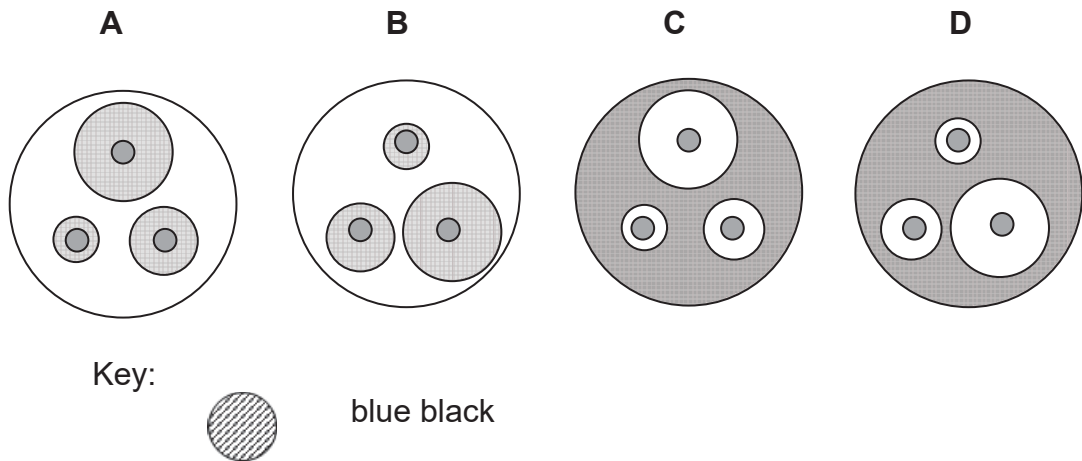

- 10 The diagram shows a section of the wall of the small intestine. Into which structure are most of the lipid components of the diet absorbed for transport to the rest of the body?

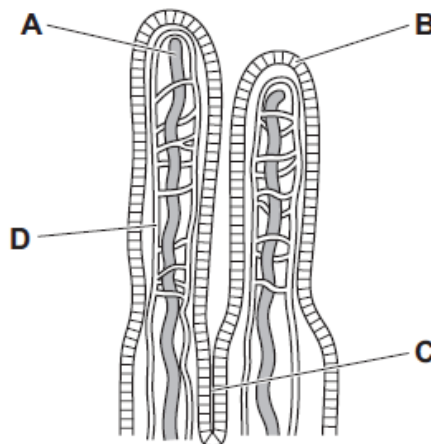

- 11 The lengths of three parts of the human alimentary canal are shown.

part	length / cm
P	350
Q	150
R	26

Which row identifies these parts?

	P	Q	R
A	colon	duodenum	ileum
B	duodenum	ileum	colon
C	ileum	colon	duodenum
D	ileum	duodenum	colon

- 12 A plant has leaves with both green and white areas. One of its leaves is partly covered with aluminium foil which blocks light.

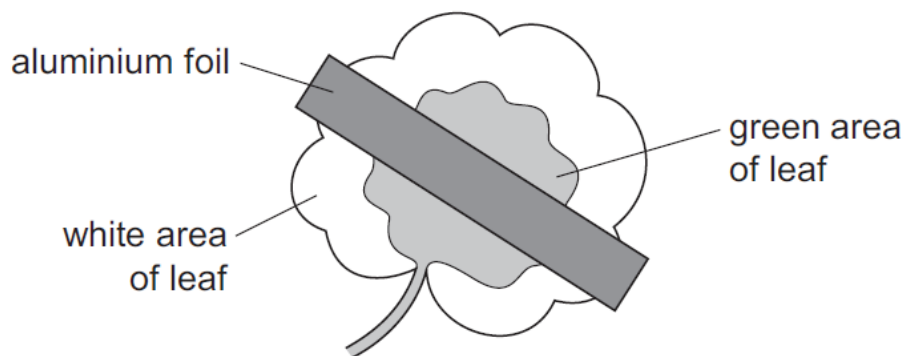

The plant is then placed under a lamp for 24 hours. After this time, discs are cut from the areas of the leaf shown, and tested with iodine solution.

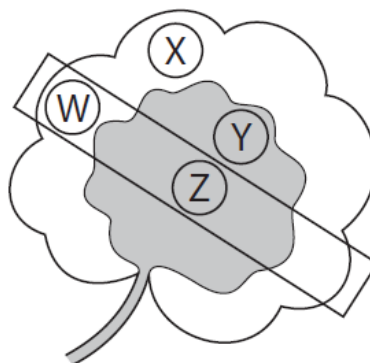

Which of the leaf discs will give a blue-black colour when tested with iodine solution?

- A** W and X **B** X only **C** Y and Z **D** Y only

- 13 The bar chart shows the average number of chloroplasts in each of three different types of leaf cells.

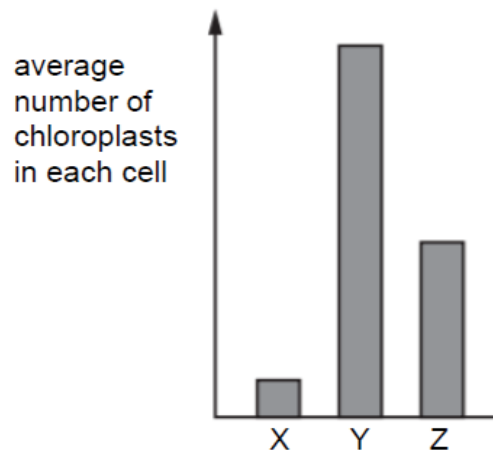

Which row correctly identifies the three different types of leaf cells?

	X	Y	Z
A	guard cell	palisade mesophyll cell	spongy mesophyll cell
B	palisade mesophyll cell	spongy mesophyll cell	guard cell
C	spongy mesophyll cell	guard cell	palisade mesophyll cell
D	spongy mesophyll cell	palisade mesophyll cell	guard cell

- 14 A patient inhales a drug.

Which chamber of the patient's heart would be the first to receive blood containing the drug?

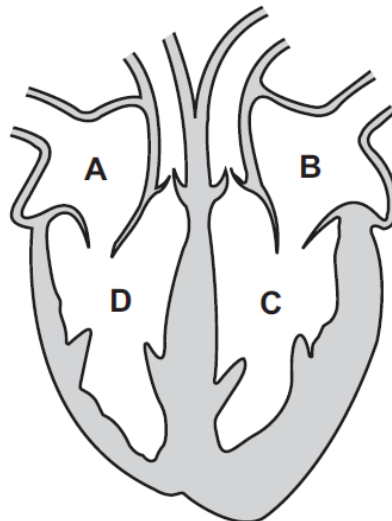

- 15 Which table shows vessels carrying blood to and from the heart, liver and lungs?

A

blood to organ	organ	blood away from organ
pulmonary artery	heart	pulmonary vein
hepatic portal vein	liver	hepatic vein
pulmonary vein	lungs	pulmonary artery

B

blood to organ	organ	blood away from organ
pulmonary artery	heart	pulmonary vein
hepatic vein	liver	hepatic portal vein
pulmonary vein	lungs	pulmonary artery

C

blood to organ	organ	blood away from organ
pulmonary vein	heart	pulmonary artery
hepatic portal vein	liver	hepatic vein
pulmonary artery	lungs	pulmonary vein

D

blood to organ	organ	blood away from organ
pulmonary vein	heart	pulmonary artery
hepatic vein	liver	hepatic portal vein
pulmonary artery	lungs	pulmonary vein

- 16 The diagram shows a section through a dicotyledonous root. Which tissue transports amino acids?

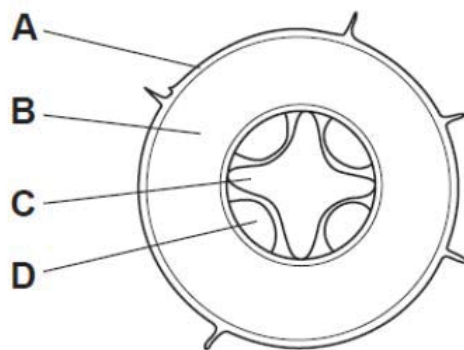

- 17 The diagram represents a cross-section of a part of a leaf.

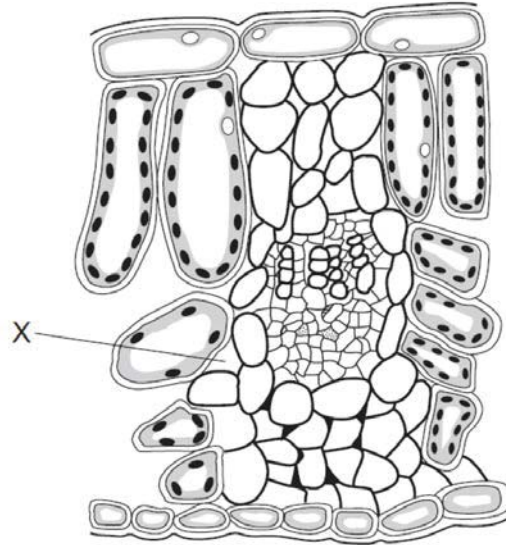

How does the water vapour content of the air at X compare to normal atmospheric air when the leaf is in the light and when it is in the dark?

	in the light	in the dark
A	higher	higher
B	higher	lower
C	lower	the same
D	the same	lower

- 18 The graph shows how the pressure and volume inside the lungs change during one complete breath.

At which point are the muscles of the diaphragm starting to contract?

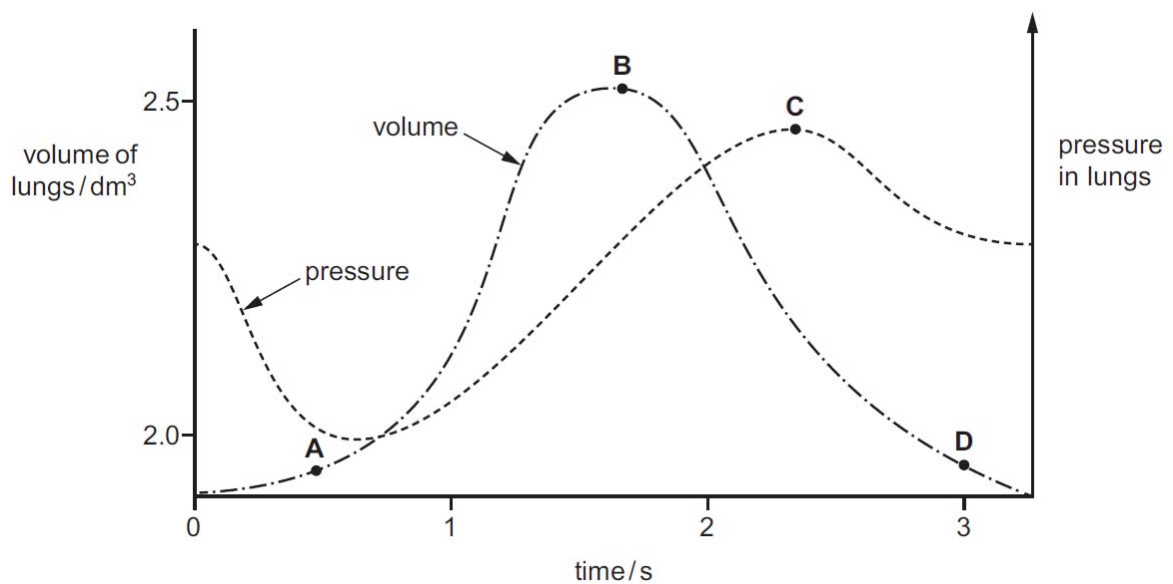

- 19 Carbonic anhydrase is an enzyme. Where is it found and what reaction does it catalyse in respiring tissue?

	location	reaction catalysed
A	alveolar cells	$\text{H}_2\text{CO}_3 \rightarrow \text{H}_2\text{O} + \text{CO}_2$
B	plasma	$\text{H}_2\text{O} + \text{CO}_2 \rightarrow \text{H}_2\text{CO}_3$
C	red blood cell	$\text{H}_2\text{CO}_3 \rightarrow \text{H}_2\text{O} + \text{CO}_2$
D	red blood cell	$\text{H}_2\text{CO}_3 \rightarrow 2\text{H}^+ + \text{CO}_3^{2-}$

- 20 The diagram shows the simplified structure of a kidney nephron.

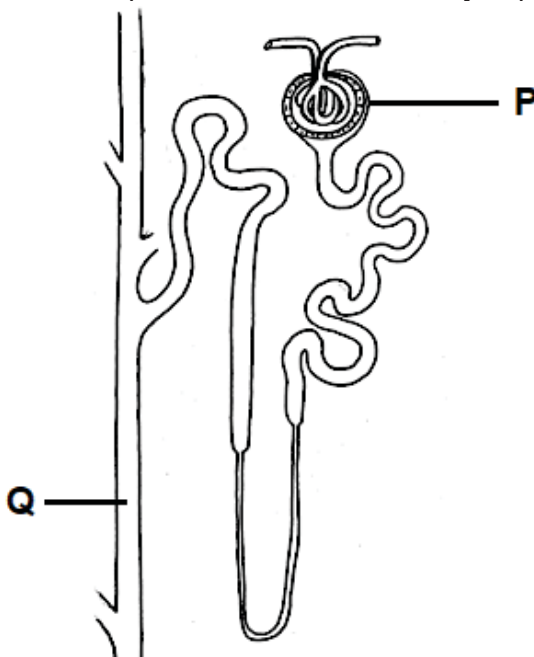

The table shows the quantities of three substances 1, 2 and 3 as they pass through parts P and Q of the nephron.

substance	quantity passing through P / g	quantity passing through Q / g
1	180	1.5
2	60	55
3	200	0

Based on the data, what are the identities of substances 1, 2 and 3?

	substance 1	substance 2	substance 3
A	water	urea	glucose
B	amino acids	water	glucose
C	glucose	urea	water
D	water	sodium ions	urea

- 21 The diagram shows a sweat gland with its blood supply. Which option correctly describes the changes in the concentration of carbon dioxide, salt and urea as blood passes from P to Q?

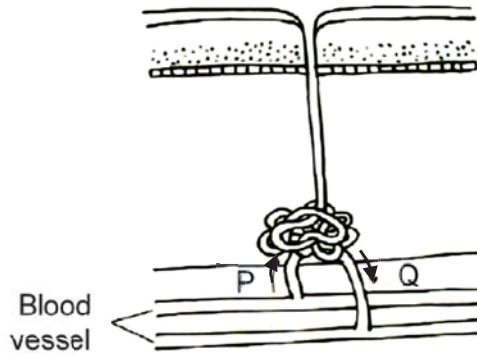

	carbon dioxide	salt	urea
A	decrease	decrease	increase
B	decrease	increase	decrease
C	increase	decrease	increase
D	increase	decrease	decrease

- 22 A man is placed in a room where the temperature is controlled at 40 °C. Measurements of his skin temperature and rate of sweating are recorded over a period of time. Which graph would most accurately represent the above situation?

Key — skin temperature - - - - rate of sweating

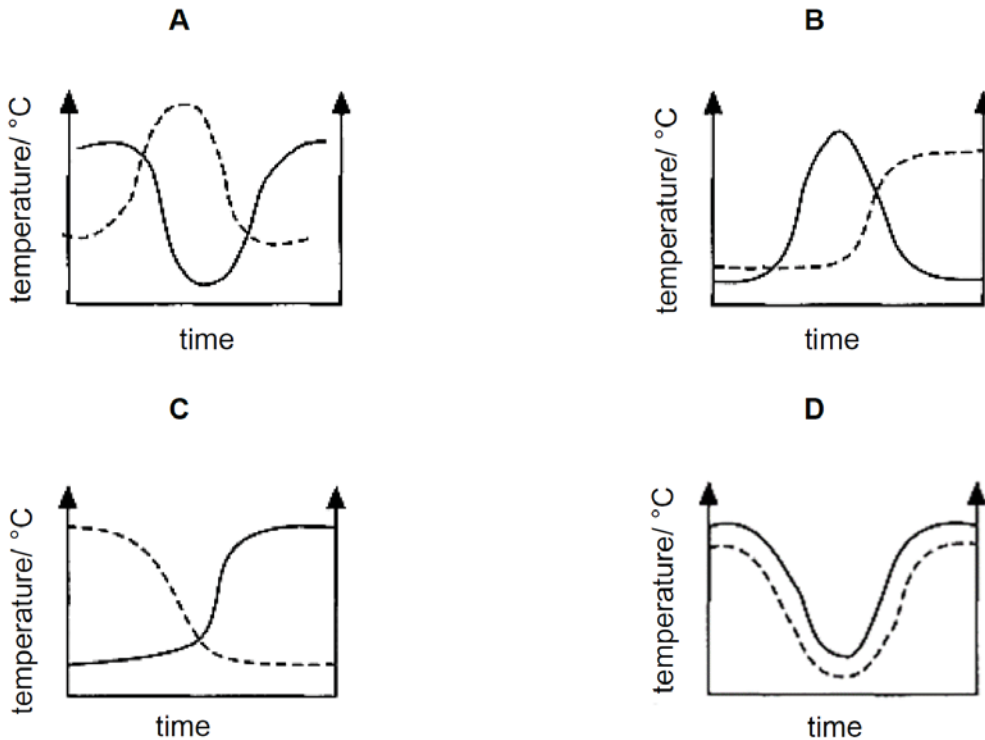

23 Which of these statements correctly describes control by **negative** feedback?

- A An injury to body tissue activates platelets in the blood and these activated platelets release chemicals which activate more platelets.
- B During the menstrual cycle, the release of oestrogen stimulates the regeneration of the uterine lining which stimulates secretion of more oestrogen.
- C The onset of contractions during childbirth causes the release of a hormone, which stimulates further contractions.
- D When blood pressure is high, nerve impulses from the brain cause the blood vessels to dilate and blood pressure is reduced.

24 The diagram shows a cell.

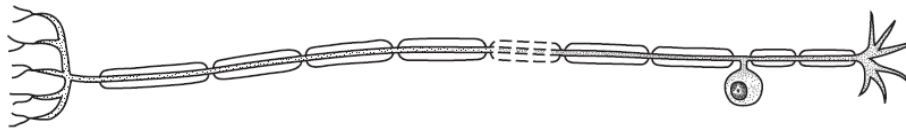

What type of cell is shown?

- A ciliated cell
- B motor neurone
- C relay neurone
- D sensory neurone

25 The diagram shows a simple reflex arc. A cut has been made along line XX.

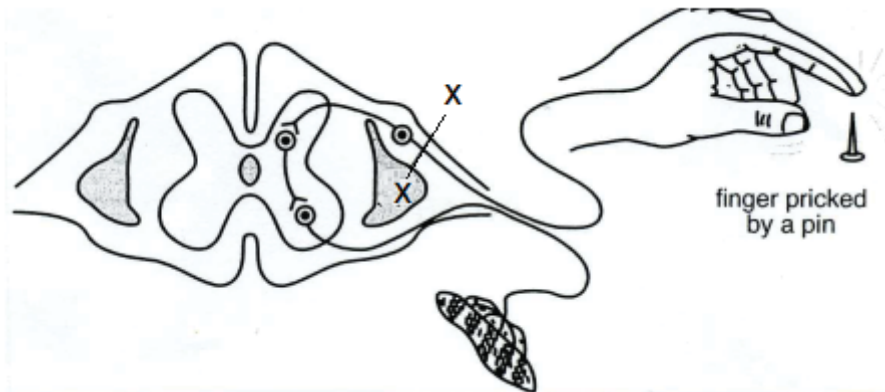

Which of the following shows the correct effect of this cut?

	pin felt	reflex arm movement	voluntary arm movement
A	no	no	yes
B	no	yes	yes
C	no	no	no
D	yes	yes	no

26 What happens when a person focuses on a near object?

	ciliary muscles	lens	suspensory ligaments
A	contract	rounded	loose
B	contract	thin	taut
C	relax	rounded	loose
D	relax	thin	taut

27 The diagram shows a section through an eye.
Which part is the effector for the response that changes the size of the pupil?

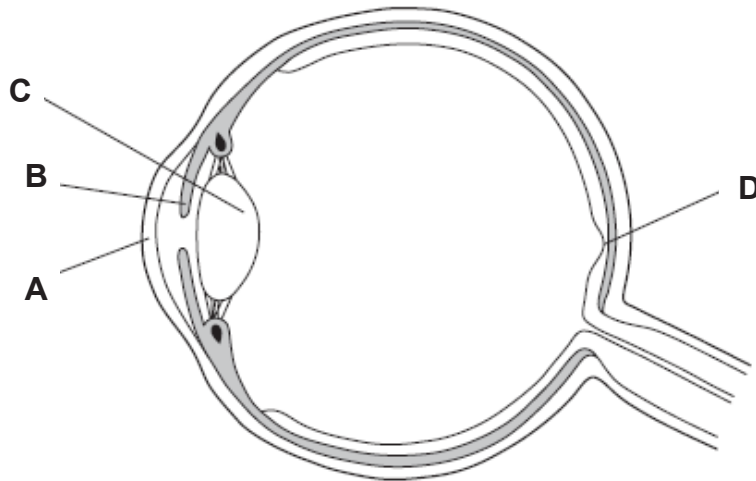

28 What are the short-term effects of adrenaline on the body?

- 1 decreased blood sugar concentration
- 2 decreased heart rate
- 3 increased blood sugar concentration
- 4 increased heart rate

- A** 1 and 2
- B** 1 and 4
- C** 2 and 3
- D** 3 and 4

29 The table gives information about endocrine glands.
Which row shows the correct information?

	gland	hormone produced	target organ	effect
A	adrenal	adrenaline	liver	decreases blood glucose concentration
B	ovaries	progesterone	uterus	ovulation occurs
C	pancreas	insulin	liver	conversion of excess glucose to glycogen
D	testes	testosterone	penis	erection occurs for sexual intercourse

- 30 A student decides to study the impact of removing certain flower parts on fruit formation in plant species X. He chooses three separate plants that are growing in the same plot under uniform conditions. The data is shown in the table below.

plant	part removed	Impact on fruit formation
1	anther	30% less fruit formed than average plant in the plot.
2	stigma	no fruit formed
3	petal	no significant impact

Which of the following conditions is **not** consistent with the above data?

- A Anthers and stigmas are crucial in sexual reproduction in species X.
 - B Pollen grains are probably unable to germinate if they land on the other parts of the carpel beside the stigma.
 - C Species X is likely to be wind pollinated.
 - D Species X relies completely on cross pollination.
- 31 The diagram shows a typical flower.



Which statement about the mode of pollination in this flower is correct?

- A The flower has large petals to attract insects for pollination.
- B The flower has long pendulous filaments to easily shake off the pollen grains during a breeze.
- C The flower has small compact stigma that do not protrude out to favour self-pollination.
- D The flower has nectar guide on the petals to facilitate cross-pollination.

- 32 The diagram below shows the female reproductive system.

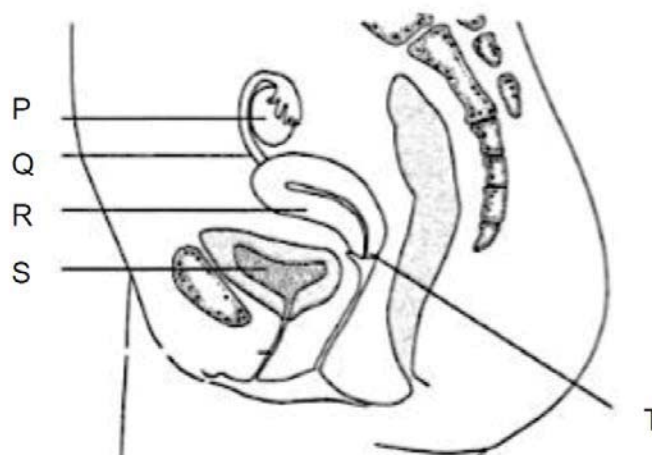

Which correctly shows the regions where the following events occur?

	implantation	fertilisation	meiosis
A	R	Q	P
B	R	P	Q
C	S	Q	R
D	T	R	P

- 33 The human immunodeficiency virus (HIV) can be transmitted in body fluid. Some examples of body fluids are listed.

- 1 blood
- 2 saliva
- 3 semen
- 4 tear fluid

Which body fluids could transmit HIV?

- A** 1, 2, 3 and 4
B 1, 2 and 3 only
C 1 and 3 only
D 3 only

34 The six diagrams show different stages during mitosis.

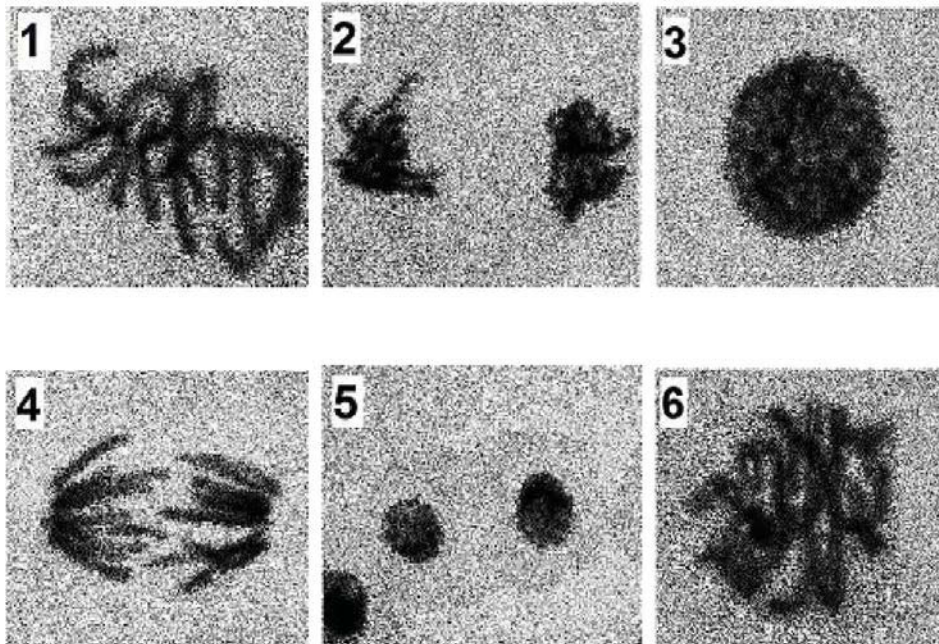

Which option shows the correct sequence of events?

- A 1, 6, 4, 2, 5, 3
- B 3, 6, 1, 4, 2, 5
- C 5, 2, 4, 1, 6, 3
- D 6, 3, 1, 4, 2, 5

35 The diagram shows the maternal and paternal chromosomes from a diploid cell.

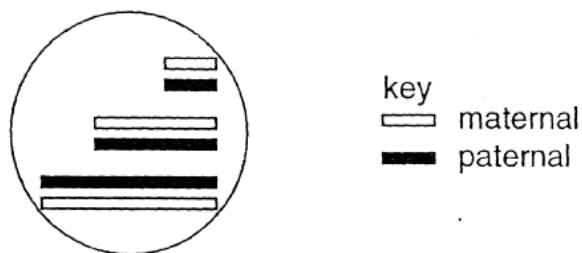

If the cell were to divide by meiosis, which diagram will show a possible viable gamete?

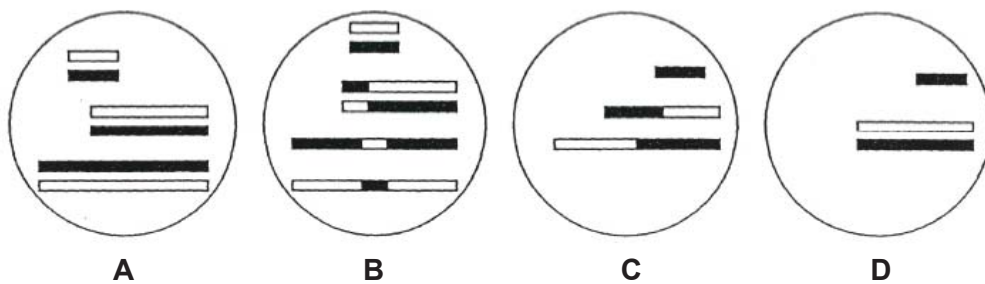

- 36 The diagram shows a family tree with the blood groups of some individuals labelled.

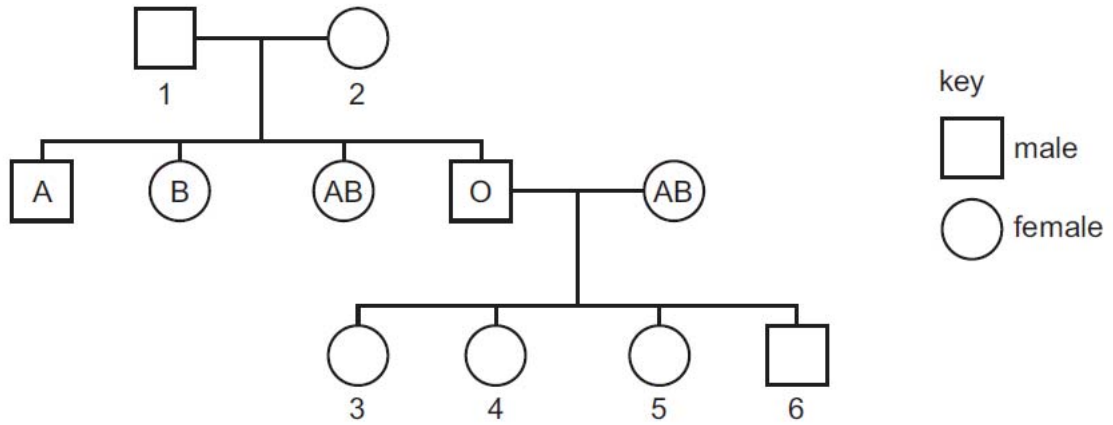

What are possible blood groups for the numbered individuals?

	1	2	3	4	5	6
A	A	B	A	A	B	B
B	A	B	A	B	AB	O
C	AB	O	A	A	B	B
D	AB	O	A	B	AB	O

- 37 In horses, there are 3 coat colour patterns, *cremello* (beige), *chestnut* (brown) and *palomino* (golden with pale coloured mane and tail).

When 2 *palomino* horses were crossed, they produce 25% *cremello*, 25% *chestnut* and 50% *palomino* horses.

Which of the following statement is true about the cross?

- A The *cremello* offspring are all heterozygotes.
- B There are 3 alleles involved in the coat colour patterns of the horses.
- C All the *palomino* offspring are heterozygotes.
- D The allele that code for chestnut is recessive to the *cremello*.

- 38 The diagram shows some stages during the asexual reproduction of a single-celled organism.

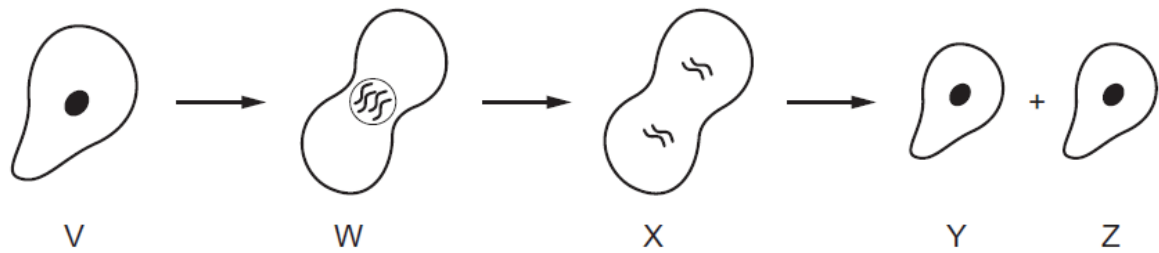

Which row correctly shows the relative amounts of DNA in each of the cells V, W, X, Y and Z?

	V	W	X	Y	Z
A	1	1	1	2	2
B	1	1	2	1	1
C	1	2	2	1	1
D	2	1	1	2	2

- 39 The diagram shows the structure of part of a DNA molecule.

Which is a nucleotide?

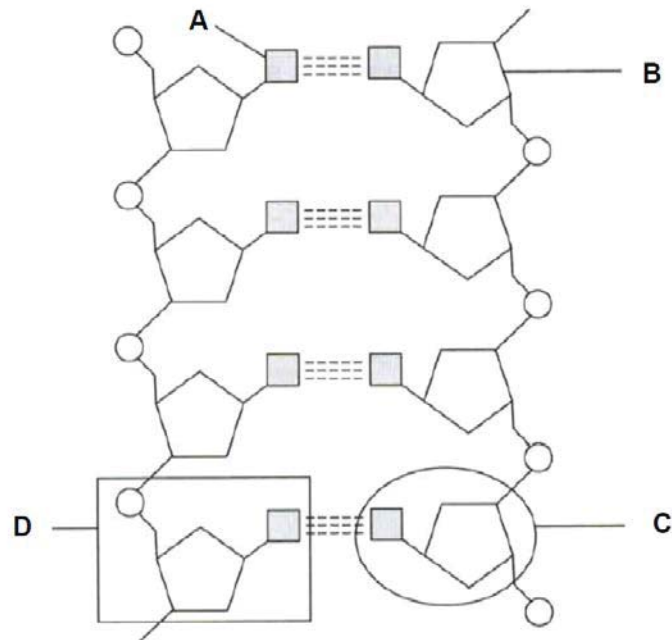

- 40 Part of a sequence of DNA from a person with a genetic disease is:

TAGTAACCACAAAGG

The corresponding sequence of DNA from a person without this genetic disease is:

TAGTAAAAACCACAAAGG

The possible mRNA codons for some amino acids are shown in the table.

amino acid	mRNA codons
1	GGU GGC GGA GGG
2	AUU AUC AUA
3	UUU UUC
4	UCU UCC UCA UCG

Which amino acid is missing from a person with this genetic disease?

- A 1
- B 2
- C 3
- D 4

End of Paper

Name :	Class	Register number
---------------	--------------	------------------------

DUNEARN SECONDARY SCHOOL DUNEARN SECONDARY SCHOOL DUNEARN SECONDARY SCHOOL DUNEARN SECONDARY SCHOOL DUNEARN SECONDARY SCHOOL
DUNEARN SECONDARY SCHOOL DUNEARN SECONDARY SCHOOL DUNEARN SECONDARY SCHOOL DUNEARN SECONDARY SCHOOL DUNEARN SECONDARY SCHOOL
DUNEARN SECONDARY SCHOOL DUNEARN SECONDARY SCHOOL DUNEARN SECONDARY SCHOOL DUNEARN SECONDARY SCHOOL DUNEARN SECONDARY SCHOOL
DUNEARN SECONDARY SCHOOL DUNEARN SECONDARY SCHOOL DUNEARN SECONDARY SCHOOL DUNEARN SECONDARY SCHOOL DUNEARN SECONDARY SCHOOL



DUNEARN SECONDARY SCHOOL Preliminary Examination 2020

Biology 6093 Paper 2 Secondary 4 Express

17 Sep 2020 (Thursday)

0800 – 0945

1 h 45 min

INSTRUCTIONS TO CANDIDATES

Section A

Answer **all** questions.

Write your answers in the spaces provided on the question paper.

Section B

Answer **all** questions 7, 8 and 9 in the spaces provided.

Paper 1	Paper 2						Sub-total for P2 Section A	/50
	A1	A2	A3	A4	A5	A6	Sub-total for P2 Section B	/30
/40	B7	B8	B9				Total marks for Paper 2	/80
							Overall marks	/ 120

Setter: Mr Ng Hock Ping

Parent's Signature:

This question paper consists of **16** printed pages including the cover page.

Section A [50 marks]
Answer all the questions in the spaces provided.

*For
Examiner's
Use*

- 1 Fig. 1.1 show the photomicrographs of a plant and an animal cell.

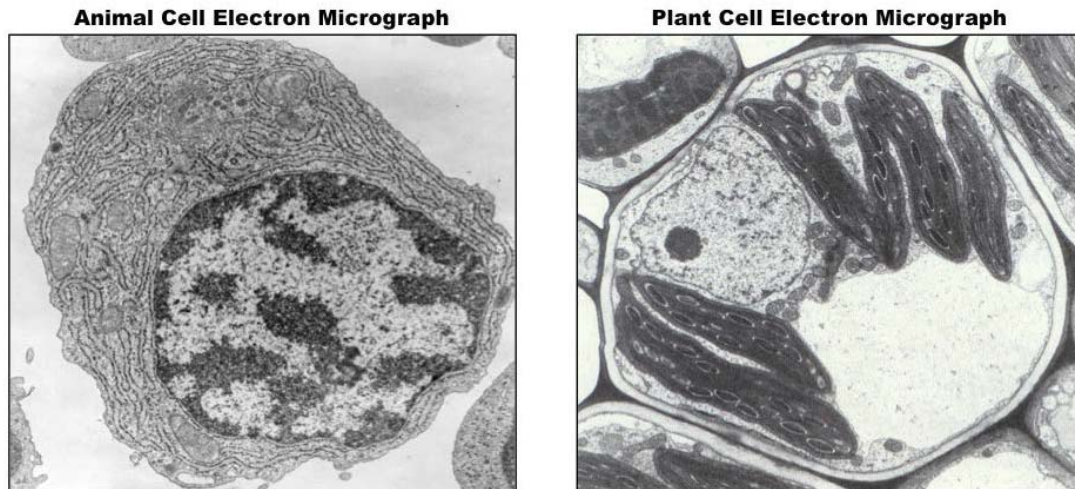

References

Cell micrographs | BioNinja. (n.d.). Visitor anti-robot validation. <https://ib.bioninja.com.au/standard-level/topic-1-cell-biology/12-ultrastructure-of-cells/cell-micrographs.html>

Fig. 1.1

Fig.1.2 shows how the structural features found in plant cells and in animal cells can be grouped together.

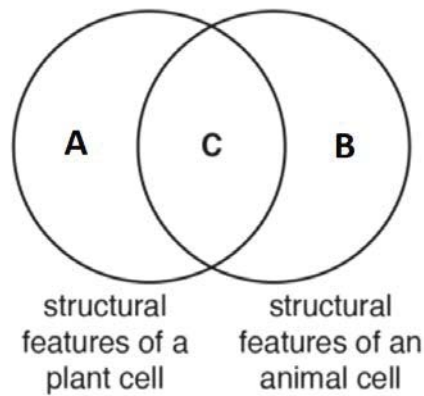

Fig.1.2

- (a) List **three** features and their functions that would be grouped in region **C** on Fig.1.2.

structural feature	function

[3]

- (b) List **two** features and their functions that would be grouped in region **A** of the structural features of a plant cell.

structural feature	function

[2]

- (c) List **one** feature and its function that would be grouped in region **B** of the structural features of an animal cell.

structural feature	function

[1]

[Total: 6]

- 2 Food supplements are substances that are often added to a person's diet. These supplements may be in the form of a tablet. The diagram shows the label from a food supplement.

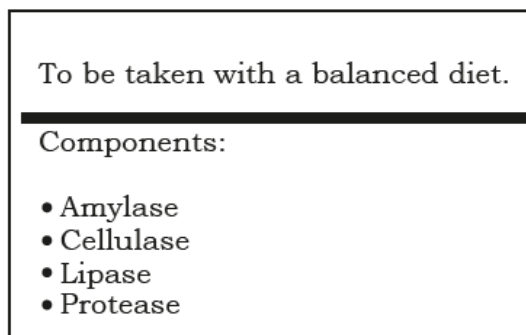

This supplement may be taken by a person whose pancreas is **not** producing enough of some of the components shown on the label.

- (a) (i) State the type of chemical that the supplement contains.

.....

[1]

- (ii) Each food group in the diet is the substrate for a specific component of the supplement. Complete the table below.

component of supplement	substrate	end product or products
amylase		
protease		
lipase		

[3]

(iii) Cellulase is a component of the supplement that is **not** usually found in the human body.
Use your knowledge of the structure of a plant cell to suggest the function of the cellulase component of the supplement.

.....
..... [1]

(b) The supplement is taken in the form of a tablet that is swallowed.
Each tablet is covered in a substance that breaks down **only** in alkaline conditions to release the components of the supplement.
Suggest why this covering is important if the supplement is to work effectively in the alimentary canal.

.....
.....
.....
.....
..... [2]

(c) Explain how the pancreas helps to regulate the blood glucose concentration as a homeostatic mechanism.

.....
.....
.....
.....
.....
.....
.....
.....

[3]
[Total: 10]

- 3 Fig. 3.1 shows the fovea which is a shallow pit in the retina of the eye of humans, which is the region of greatest acuity (sharp focus) in vision. The fovea contains no rod cells but numerous cone cells. Cones cells detect primary colours which rod cells detect the presence of light. There are also no blood vessels or thick layer of nerve fibers interposed between the cones and the incoming light, as is the case in the rest of the retina.

For
Examiner's
Use

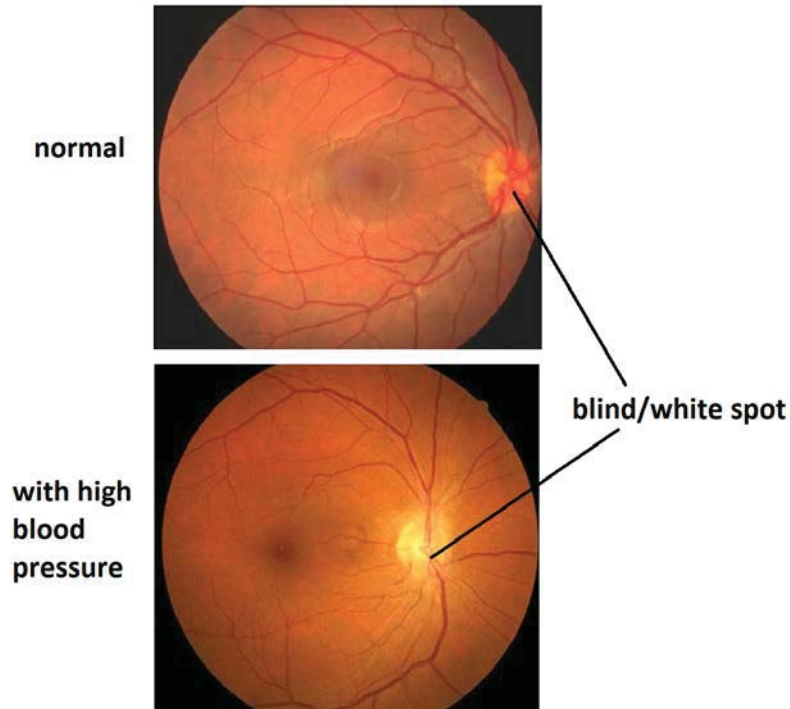

Retina abnormalities: 14 signs of systemic disease. (n.d.). Medscape Drugs & Diseases - Comprehensive peer-reviewed medical condition, surgery, and clinical procedure articles with symptoms, diagnosis, staging, treatment, drugs and medications, prognosis, follow-up, and pictures. <https://reference.medscape.com/features/slideshow/retina#4>

Fig. 3.1

- (a) Suggest why the fovea contains
- (i) no rod cells but numerous cone cells.
-
-
- [2]
- (ii) no blood vessels or thick layer of nerve fibers.
-
-
- [2]
- (b) **Mark and label** on Fig.3.1, the likely position of the fovea. [1]

- (c) A patient with high blood pressure tend to have occlusions in the arterioles which lead to less bends and branches as seen in Fig. 3.1. Suggest how these differences (compared to the normal arterioles) may affect the vision of the person.

.....

.....

.....

.....

..... [2]

[Total: 7]

- 4 A seal is a mammal that spends most of its time in the sea. It breathes and respire in a very similar way to a human, but when it dives to hunt and catch fish, it is capable of staying under water for up to 20 minutes. The graph shows the percentage concentrations of oxygen and carbon dioxide, and the concentration of lactic acid in a seal's blood over a 40 minute period during which it dives to hunt and catch fish.

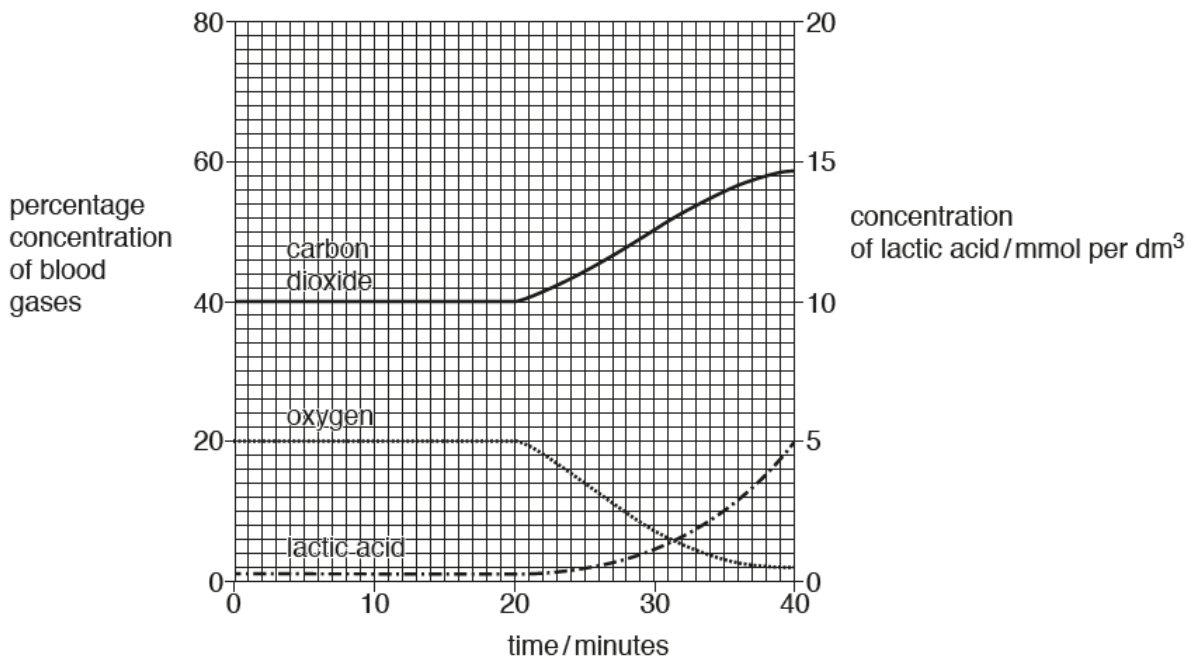

- (a) State the word equation of the chemical process that is taking place in the seal's muscles before it dives.

..... [1]

(b) (i) State how long after the start of the time period the seal begins its dive.
..... [1]

(ii) State the percentage of oxygen in the seal's blood 40 minutes after the start of the time period.
..... [1]

(c) Name the chemical process which starts to take place in the seal's muscles during its dive and explain how the graph supports your answer.
process
explanation
.....
.....
.....
.....
.....
..... [4]

(d) Suggest and explain what would happen to the concentration of lactic acid in the seal's blood when it returns to the surface of the sea after its dive.
.....
.....
.....
.....
.....
.....
..... [3]

[Total: 10]

5 The diagram shows three varieties, **C**, **D** and **E**, of the same species of insect.

For
Examiner's
Use

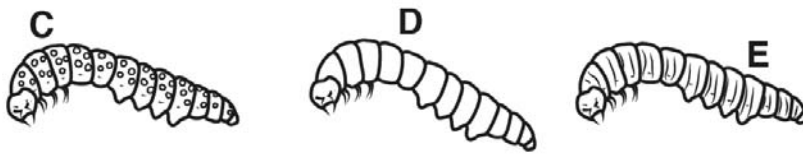

Two alleles, **T** and **t**, control the body pattern of the insects.
 Insects with dots (**C**) are homozygous dominant.
 Insects with stripes (**E**) are homozygous recessive.
 Plain insects (**D**) are heterozygous.

(a) (i) Name the part of a cell that contains the genes. [1]

(ii) Define each of the following terms:

gene

.....

dominant allele

.....

.....

[3]

(b) Complete the genetic diagram below for the cross between insect **C** and insect **D**. State the genotype and phenotype of offspring.

		gametes of insect C	
gametes of insect D	
	

[3]

- (c) The diagram shows three varieties, **C**, **D** and **E**, of the same species of insect feeding on three different leaf patterns, **F**, **G** and **H**, of the same species of plant respectively.

For
Examiner's
Use

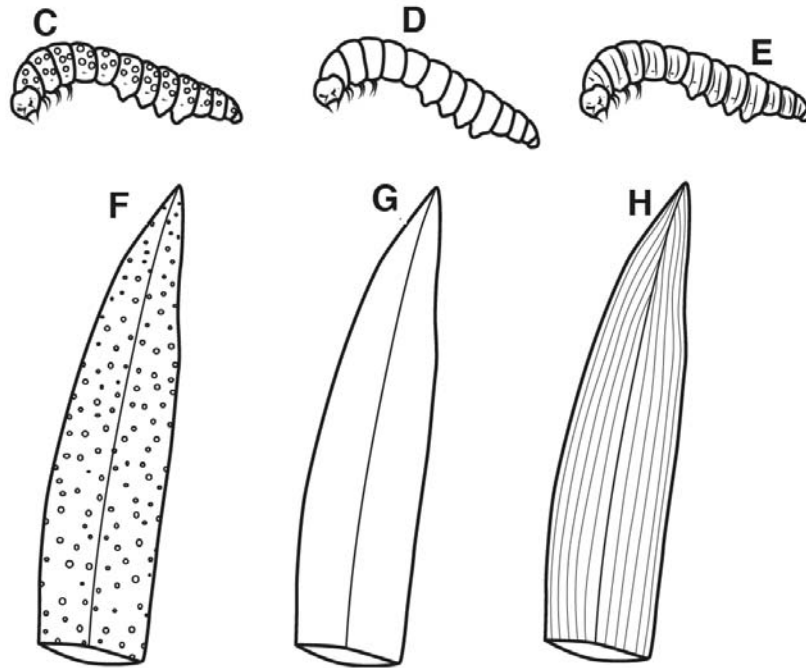

Explain why all three varieties of insect will continue to be produced even in areas where all the plants have plain leaves but the plain variety will prevail in abundance.

.....

.....

.....

.....

.....

.....

.....

.....

[3]
[Total: 10]

- 6 (a) The statements **E** to **L** relate to the process of cell division.
E is used in the repair of damaged tissues
F results in the production of diploid cells
G results in the production of gametes
H results in the chromosome number being halved
J gives rise to genetically identical cells
K takes place in both animals and plants
L is used in the process of asexual reproduction

Complete the table by writing each statement letter in the correct box to show whether the statement relates to mitosis only, meiosis only, or to both. The first letter has been written in the correct box for you.

mitosis only	meiosis only	both mitosis and meiosis
E		

[3]

- (b) Fig. 6.1 shows a similar stage occurring in both mitosis and meiosis.

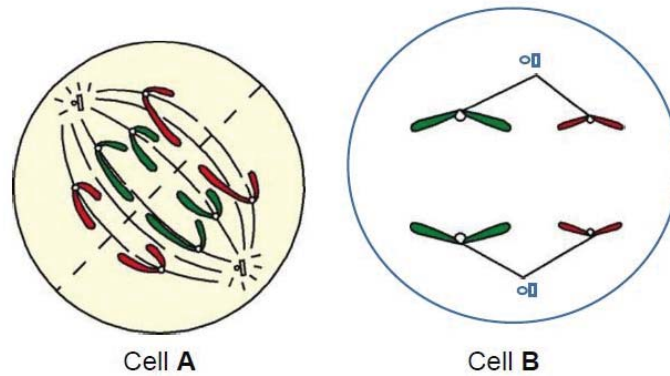

Fig. 6.1

- (i) Which cell is in meiosis stage? Cell [1]

- (ii) Identify and explain the significance of the stage in cell A.

.....
 [2]

- (iii) Suggest what happens if there is an error in the replication of DNA during cell division in cell A.

.....
 [1]

[Total: 7]

Section B [30 marks]

Answer **all** questions in the spaces provided.

- 7 Fig. 7.1 shows a potometer used by a student to compare the rates of transpiration of two different plants, a mesophyte and a xerophyte.

A mesophyte is a plant adapted to a moist environment, while a xerophyte is adapted to a dry environment.

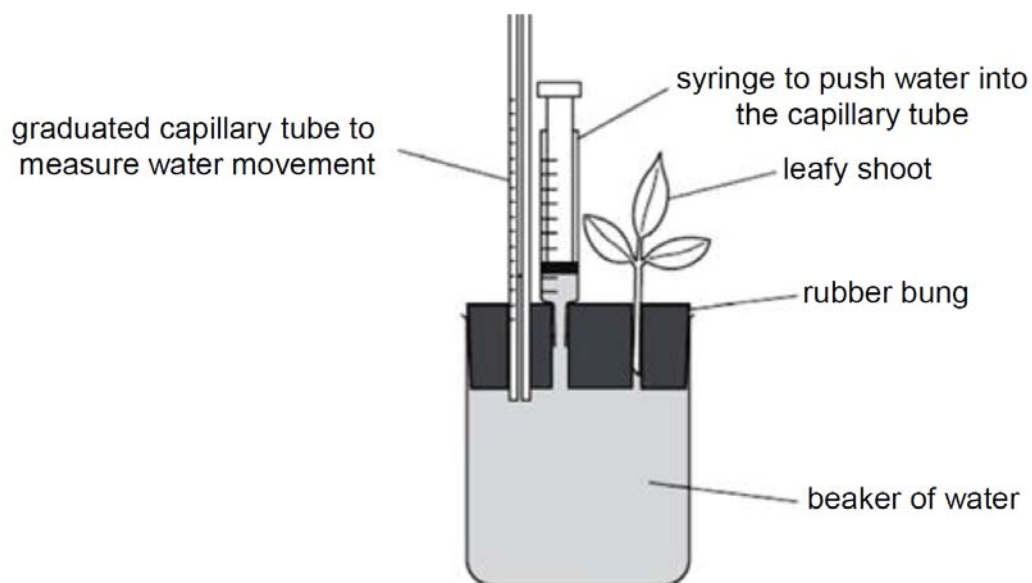

Fig. 7.1

The student measured the total amount of water lost via transpiration every hour, and recorded his data in Table 7.1 below.

Table 7.1

time/ h	volume of water lost via transpiration by plant/ cm ³
0	0
1	2
2	3
3	4
4	6
5	8
6	12
7	30
8	60

(a) On the grid below, draw a graph to represent the data presented in Table 7.1.

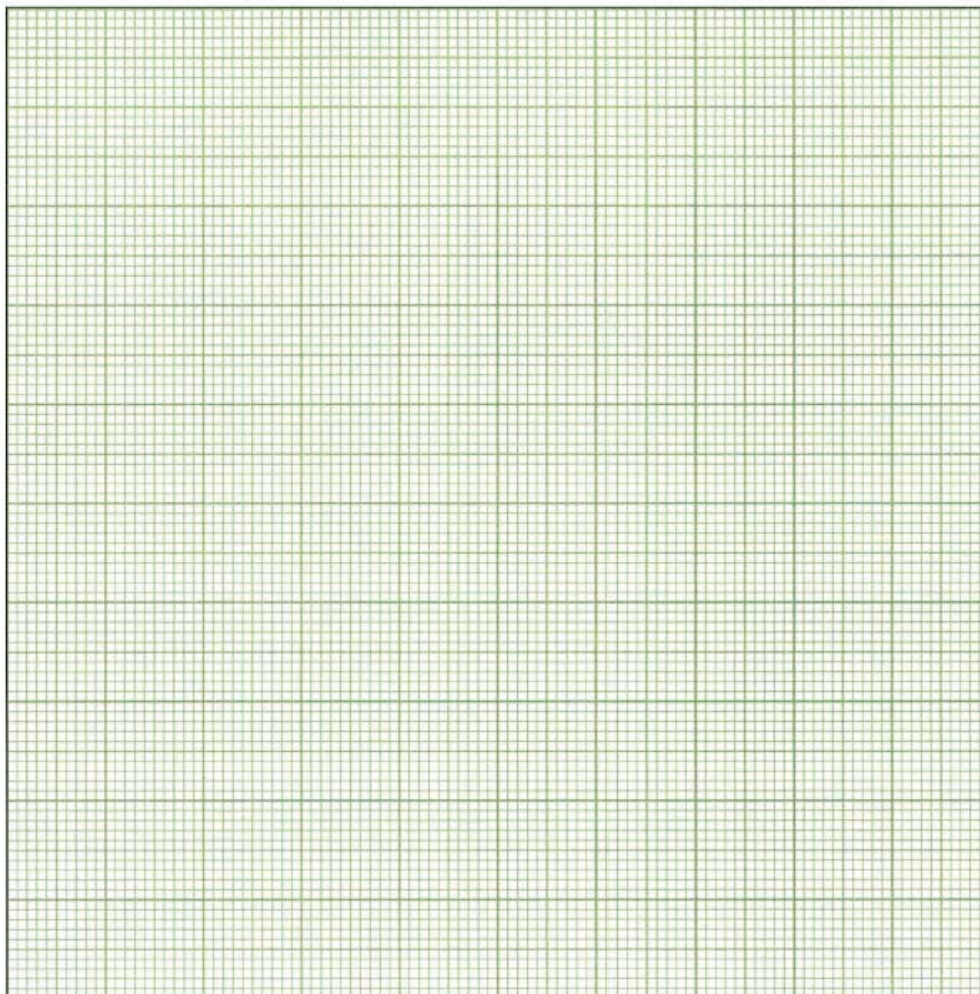

[4]

(b) Using information from the graph you have drawn, calculate the rate of water lost at the 6th hour of the experiment.
Show your working on the graph, as well as in the space provided below.

rate of water lost at the 6th hour:[3]

(c) On the same grid, sketch a graph to represent the volume of water that you would expect the xerophyte to lose under the same conditions.

[1]

(d) Describe two structural adaptations commonly found on the leaves of a xerophyte.

1

.....

2

..... [2]

[Total: 10]

8 Below are some information from Freight Farm brochure on their specially-converted freight container called the Greenery which grows vegetables year-round.

Controlled Environment Agriculture in the Greenery

Guides, Greenery Guide · October 18, 2019

Controlled Environment Agriculture is the Secret to Growing Food Year-round



References

The greenery - Smart container farm | Freight farms. (n.d.). Freight Farms. Retrieved August 11, 2020, from <https://www.freightfarms.com/greenery>

Seedlings are grown in hydroponic vertical trays and illuminated by blue and red LED lights inside the Greenery as shown in photographs A-C.

For
Examiner's
Use



photograph A



photograph B



photograph C

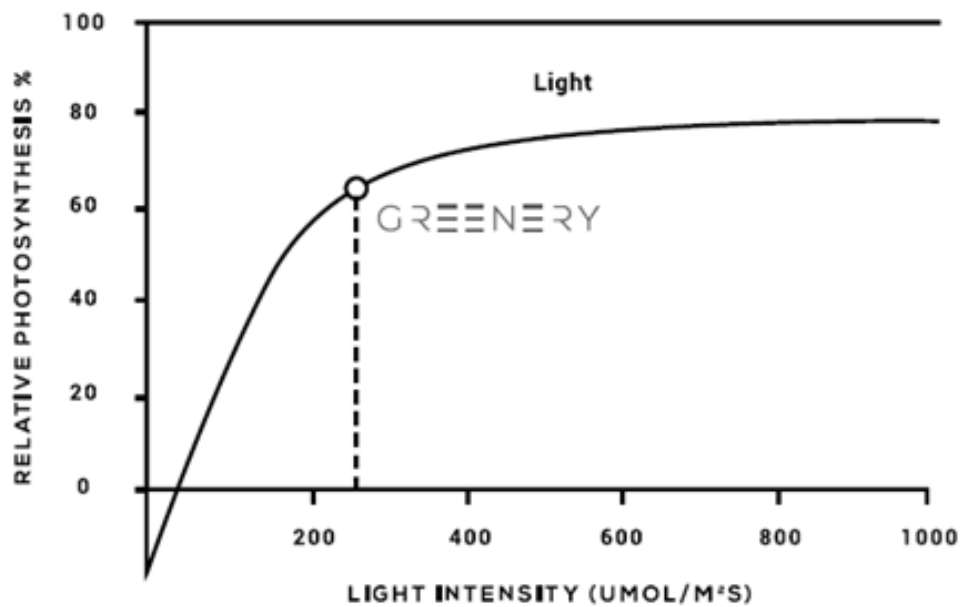

Graph 8.1

Graph 8.1 shows how the rate of plant growth (the rate of photosynthesis) is directly affected by light intensity.

(a) Describe the intake of water and minerals by the seedlings in hydroponic medium as shown in photograph **A**.

.....
.....
.....
.....
.....
..... [3]

(b) With reference to photograph **B** and Graph 8.1, explain clearly

- (i) why red and blue LED lights of $250 \mu\text{mol}/\text{m}^2\text{s}$ are illuminated onto the plants for 18 hours per day.
- (ii) how two other limiting factors are controlled in the Greenery to increase the crop yield year-round.

.....
.....
.....
.....
.....
.....
.....
.....
..... [5]

(c) The plants with flowers in photograph **C** may produce fewer offspring and only small variations compared with crops grown naturally. Suggest a solution to resolve this issue.

.....
.....
..... [2]

[Total: 10]

9 Following sexual intercourse in humans, fertilisation may take place.

(a) Describe the process of fertilisation and the early development of a ball of cells.

.....
.....
.....
.....
.....
.....
.....
.....
..... [4]

(b) The ball of cells may then become implanted in the wall of the uterus and form a developing fetus. Describe how a developing fetus obtains and uses the **named** substances it needs and removes its **named** waste products.

.....
.....
.....
.....
.....
.....
.....
.....
.....
.....
.....
.....
.....
.....
.....
..... [6]

