

Visit

FreeTestPaper.com

for more papers

- 1 A student weighs out a fixed mass of copper and sulfur separately. She heats the copper and sulfur together in a closed container to produce copper(II) sulfide. After the reaction is complete, the unreacted sulfur is removed (all the copper has reacted) and the copper(II) sulfide formed is weighed. The table shows the results of the investigation.

Mass of copper before reaction	x g
Mass of sulfur before reaction	y g
Mass of copper(II) sulfide formed	z g
Mass of unreacted sulfur	p g

What is the value of p in terms of x , y and z ?

- A $z - y$
 B $y + z - x$
 C $y - z$
 D $x + y - z$

- 2 Samples of *Chye Sim* and *Kailan* vegetables were tested to determine if the poisonous insecticides A, B and C were present in them. The diagram below shows the results of the tests.

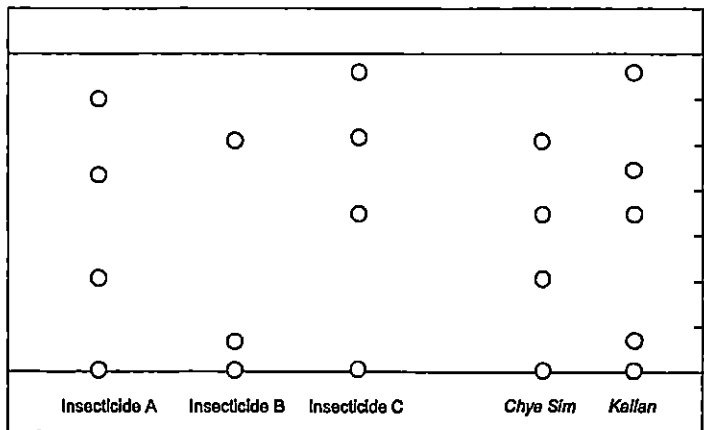

Which of the following statements is true based on the chromatogram above?

- A Only *Chye Sim* contains at least one of the insecticides, A, B and C
 B Only *Kailan* contains at least one of the insecticides, A, B and C.
 C Both *Chye Sim* and *Kailan* contain at least one of the insecticides A, B and C
 D Both *Chye Sim* and *Kailan* do not contain any of the insecticides A, B and C

- 3 The following apparatus was used to separate 2 miscible liquids S (boiling point 60°C) and T (boiling point 90°C)

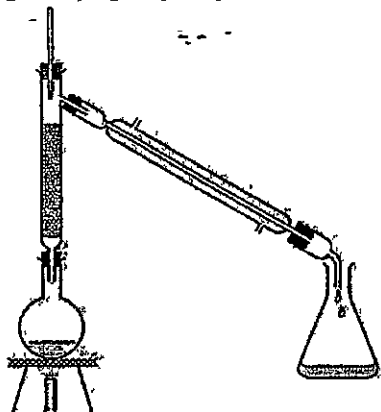

What is the graph obtained when the volume of distillate is plotted against temperature?

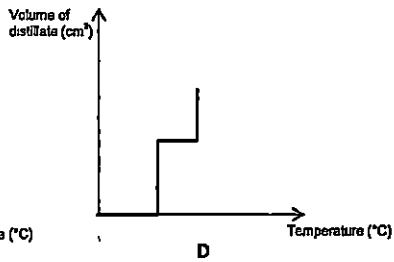
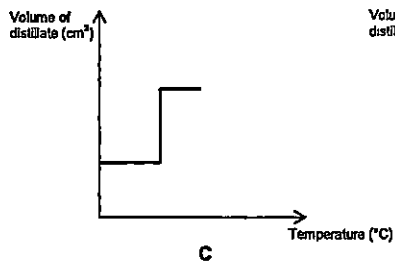
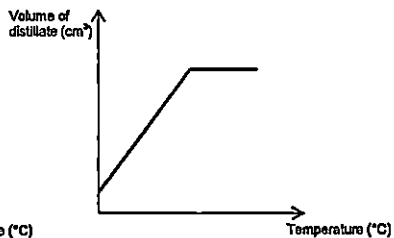
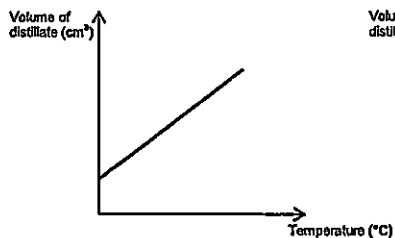

4 Study the following statements in a student's notebook

- I In a solid, the particles are stationary and held in fixed positions due to strong forces of attraction
- II When a solid is heated, the particles expand and become larger.
- III At the melting point, the particles are able to slide and roll over one another
- IV When the boiling point is reached, evaporation and boiling start to take place and the gas is formed

Which of the above statement(s) is(are) true?

- A III only
- B I and II only
- C I, II and III only
- D I, II, III and IV

5 In gold jewellery, the metal gold is usually mixed with copper and silver. Which of the following changes in physical properties does not happen when the alloy is formed?

- A Density decreases
- B Hardness increases
- C Colour changes
- D Malleability increases

6 A major component of bricks is a compound consisting of elements K and L chemically combined together

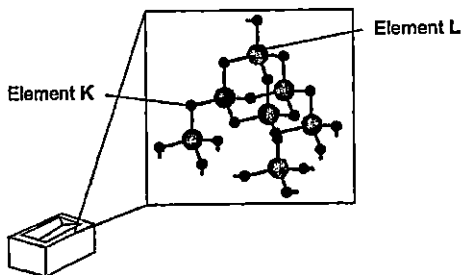

What are elements K and L?

	Element K	Element L
A	Carbon	Silicon
B	Silicon	Carbon
C	Oxygen	Silicon
D	Silicon	Oxygen

- 7 The atomic number of beryllium is 4
What is the electronic configuration of the beryllium ion?

A 2
B 2 2
C 2 7
D 2 8

- 8 A student uses the following apparatus to carry out a series of experiments to compare the rate of diffusion between different gases K, L, M and N

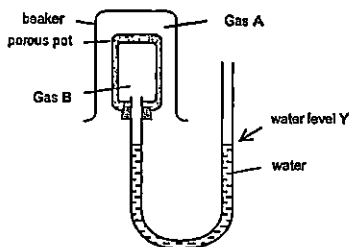

The table below summarises the observations made

Experiment	Gas A	Gas B	Observations after 5 mins
1	K	L	Water level Y rises
2	M	N	Water level Y falls
3	L	N	Water level Y rises

Which of the following correctly lists the gases in order of increasing relative molecular mass?

A K, L, M, N
B K, L, N, M
C M, N, L, K
D M, L, N, K

- 9 4 g of hydrogen is mixed with 16 g of oxygen and the mixture is ignited. Which of the following correctly describes the mixture at the end of the reaction?

	Mass of Hydrogen Left	Mass of Oxygen Left	Mass of Water Formed
A	0 g	0 g	20 g
B	0 g	8 g	12 g
C	2 g	8 g	20 g
D	2 g	0 g	18 g

- 10 The percentage composition by mass of a compound containing carbon, fluorine and chlorine is as follows

Carbon 18.05% Fluorine 28.50% Chlorine 53.45%

- Which of the following could be the molecular formula of this compound?

- A CF_3Cl
 B CF_2Cl_2
 C $\text{C}_2\text{F}_2\text{Cl}_2$
 D $\text{C}_2\text{F}_2\text{Cl}$

- 11 Which one of the samples contains the most atoms?

- A 1.5 mol of CO_2
 B 0.5 mol of C_2H_6
 C 3.0 mol of He
 D 1.0 mole of SO_3

- 12 A sample of 2.50 g fertilizer was analysed for its sulfate content. After a series of procedures, 2.33 grams of barium sulfate were precipitated from the fertiliser. What is the percentage composition by mass of sulfate in the fertiliser?

- A 38.4%
 B 41.2%
 C 61.6%
 D 93.2%

- 13 Three electrochemical cells are set up using copper metal and three unknown metals, U, V and W as electrodes, immersed in dilute sulfuric acid of the same concentration. The voltage produced in each cell is given in the table below.

Cell	Metals used	Voltage
1	Copper and U	0.45
2	Copper and V	1.11
3	Copper and W	2.71

- Which of the following correctly list the metals U, V and W in the order of increasing ease of oxidation?

- A U, V, Copper, W
 B W, V, Copper, U
 C Copper, U, V, W
 D Copper, W, V, U

14 What happens to the positive ions at the cathode during electrolysis?

- A Nothing happens to the ions
- B The ions lose electrons to form positive ions
- C The ions lose electrons to form neutral atoms
- D The ions gain electrons to form neutral atoms

15 Concentrated aqueous potassium chloride is electrolysed using carbon electrodes
What happens to the electrolyte?

- A It becomes more acidic.
- B It becomes more alkaline
- C It becomes more dilute
- D It becomes more concentrated

16 Which of the following correctly describes what takes place in a hydrogen-oxygen fuel cell?

- A Hydrogen ions are reduced at the positive electrode to form hydrogen
- B Hydrogen ions are oxidized at the positive electrode to form hydrogen
- C Hydrogen gas is reduced at the negative electrode to form water
- D Hydrogen gas is oxidized at the negative electrode to form water

17 Which of the following statements is true for an endothermic reaction?

- A Energy is absorbed from the surroundings and temperature increases
- B Energy is released to the surroundings and the temperature increases
- C Energy is absorbed from the surroundings and temperature decreases
- D Energy is released to the surroundings and temperature decreases

18 The equation for the reaction between magnesium and hydrochloric acid is given below



Which statement about this reaction is incorrect?

- A The products possess less energy than the reactants
- B The bonds of the reactants are stronger than the bonds of the products
- C The total energy change in bond formation is more than that in bond breaking
- D The magnesium has been oxidised.

19 Which of the following graphs represents how the rate of reaction varies with time when an excess of zinc reacts with dilute hydrochloric acid?

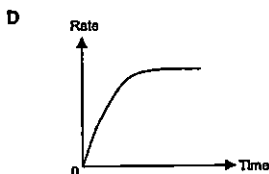
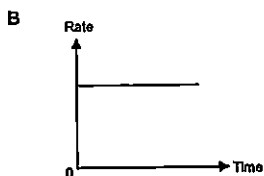
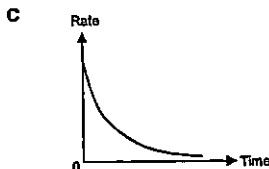
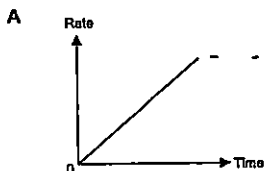

20 Which of the following is the strongest reducing agent?

- A chlorine gas
- B chloride ion
- C bromine gas
- D bromide ion

21 In which reaction is the underlined substance not reduced?

- A $\text{KBrO}_3 + 5\text{KBr} + 6\text{HNO}_3 \rightarrow 6\text{KNO}_3 + 3\text{Br}_2 + 3\text{H}_2\text{O}$
- B $3\text{CH}_3\text{OH} + 4\text{MnO}_4^- \rightarrow 3\text{HCOOH} + 4\text{MnO}_2$
- C $\text{Ag}_2\text{CO}_3 + 2\text{NaOH} \rightarrow \text{Ag}_2\text{O} + \text{Na}_2\text{CO}_3 + \text{H}_2\text{O}$
- D $\text{PbO}_2 + 4\text{HCl} \rightarrow \text{PbCl}_2 + \text{Cl}_2 + 2\text{H}_2\text{O}$

22 A sample of air polluted with sulfur dioxide was passed through aqueous potassium iodide and acidified aqueous potassium permanganate. Which pair of colour changes are both correct?

	Aqueous potassium iodide	Acidified aqueous potassium permanganate
A	No change	Purple to colourless
B	Colourless to brown	Colourless to purple
C	No change	Colourless to purple
D	Brown to colourless	Purple to colourless

27 Which statements explain why aluminium is preferred to iron for making drink cans?

- I Aluminium is lighter than iron
- II Aluminium corrodes less easily than iron
- III Aluminium is a better conductor of heat than iron

- A I and II only
- B I and III only
- C II and III only
- D I, II and III only

28 Which of the following explains why recycling ensures that metals will be available in the future?

- A Dumping of metals in landfill sites is unsightly
- B Recycling avoids the environmental damage caused by mining for metals
- C Recycling costs less than obtaining metals from their ores
- D There are only limited amounts of metals in the Earth's surface

29 Which reaction produces most of the carbon monoxide used to extract iron in the blast furnace?

- A Burning coke in air
- B Reacting coke with carbon dioxide
- C Reacting iron(III) oxide with coke
- D Decomposition of limestone

30 Metal U displaces metal V from an aqueous solution of the nitrate of V
 Metal W reacts with cold water to give hydrogen, but metal U gives hydrogen only when reacted with steam
 Metal U can be extracted from its oxide by reaction with carbon but not with hydrogen
 What could elements U, V and W be?

	U	V	W
A	Magnesium	Lead	Sodium
B	Zinc	Copper	Calcium
C	Iron	Silver	Calcium
D	Copper	Iron	Magnesium

31 Which of the following gases cannot be removed from the exhaust gases of a petrol powered car by its catalytic convertor?

- A Carbon dioxide
- B Carbon monoxide
- C Nitrogen dioxide
- D Hydrocarbons

32 The table below gives the relative concentrations of polluting gases in the air in four different industrialised cities. In which city, A, B, C or D, are limestone buildings most threatened by pollution?

	sulfur dioxide	nitrogen dioxide	ozone
A	17	46	23
B	32	33	30
C	38	40	11
D	45	14	21

33 Which of the following is NOT a problem associated with plastics?

- A Burning plastics gives off toxic gases
- B Disposal of plastics by burying can cause shortage of landfill sites
- C Plastics made from plants are biodegradable.
- D Manufacture of plastics leads to exhaustion of non-renewable energy resources

34 What process/reaction is occurring when ethene and octane are obtained from decane, $C_{10}H_{22}$?

- A Cracking
- B Polymerisation
- C Fractional Distillation
- D Combustion

35 Nonane is an alkane present in petrol. What are the products formed when nonane is completely burnt in air?

- A carbon dioxide and hydrogen
- B carbon monoxide and water
- C carbon dioxide and water
- D carbon dioxide, carbon monoxide and water

36 Which of the following compounds can turn orange acidified potassium dichromate(VI) green?

- A CH_3CH_3
- B CH_3CH_2OH
- C CH_3COOH
- D CH_3COOCH_3

37 One possible structure of $C_4H_6Br_2$ is

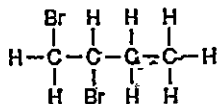

Which of the following are isomers of this organic compound?

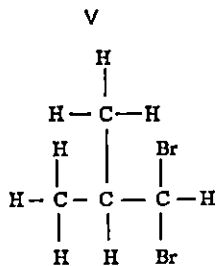
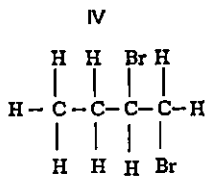
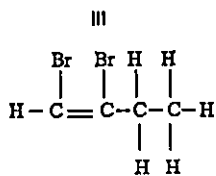
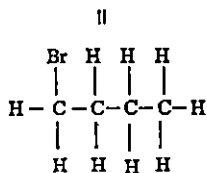
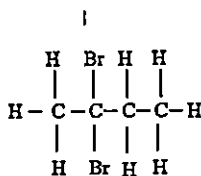

- A I and V only
 B II and III only
 C III, IV and V only
 D I, IV and V only

38 What is the molecular formula of the ester formed when propanol is reacted with butanoic acid?

- A $C_2H_5CO_2C_4H_9$
- B $C_3H_7CO_2C_3H_7$
- C $C_3H_7CO_2C_4H_9$
- D $C_4H_9CO_2C_3H_7$

39 A polymer has the following structure

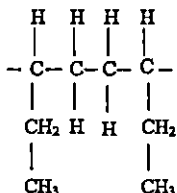

Its monomer is

- A propene
- B butene
- C propane
- D butane

40 The diagram shows a repeat unit of a polymer

Which of the following statements about the polymer and the monomers it is made from is/are true?

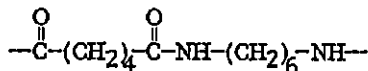

- I The polymer is made from the joining of many unsaturated monomers
- II One of its monomers can react with sodium hydroxide
- III The polymer is a polyester
- IV If the total mass of the monomers reacted together to form the polymer is 1000kg, the maximum mass of polymer formed will also be 1000kg

- A II only
- B I and III only
- C II and IV only
- D II, III and IV only

DATA SHEET
The Periodic Table of the Elements

I		II		Group										III	IV	V	VI	VII	0																																																																												
7 Li 3 Lithium	8 Be 4 Beryllium	9 B 5 Boron	10 C 6 Carbon	11 Na 11 Sodium	12 Mg 12 Magnesium	13 Al 13 Aluminum	14 Si 14 Silicon	15 P 15 Phosphorus	16 S 16 Sulfur	17 Cl 17 Chlorine	18 Ar 18 Argon	19 K 19 Potassium	20 Ca 20 Calcium	21 Sc 21 Scandium	22 Ti 22 Titanium	23 V 23 Vanadium	24 Cr 24 Chromium	25 Mn 25 Manganese	26 Fe 26 Iron	27 Co 27 Cobalt	28 Ni 28 Nickel	29 Cu 29 Copper	30 Zn 30 Zinc	31 Ga 31 Gallium	32 Ge 32 Germanium	33 As 33 Arsenic	34 Se 34 Selenium	35 Br 35 Bromine	36 Kr 36 Krypton	37 Rb 37 Rubidium	38 Sr 38 Strontium	39 Y 39 Yttrium	40 Zr 40 Zirconium	41 Nb 41 Niobium	42 Mo 42 Molybdenum	43 Tc 43 Technetium	44 Ru 44 Ruthenium	45 Rh 45 Rhodium	46 Pd 46 Palladium	47 Ag 47 Silver	48 Cd 48 Cadmium	49 In 49 Indium	50 Sn 50 Tin	51 Sb 51 Antimony	52 Te 52 Tellurium	53 I 53 Iodine	54 Xe 54 Xenon	55 Ba 55 Barium	56 La 56 Lanthanum	57 Ce 57 Cerium	58 Pr 58 Praseodymium	59 Nd 59 Neodymium	60 Pm 60 Promethium	61 Sm 61 Samarium	62 Eu 62 Europium	63 Gd 63 Gadolinium	64 Tb 64 Terbium	65 Dy 65 Dysprosium	66 Ho 66 Holmium	67 Er 67 Erbium	68 Tm 68 Thulium	69 Yb 69 Ytterbium	70 Lu 70 Lutetium	71 Hf 71 Hafnium	72 Ta 72 Tantalum	73 W 73 Tungsten	74 Re 74 Rhenium	75 Os 75 Osmium	76 Ir 76 Iridium	77 Pt 77 Platinum	78 Au 78 Gold	79 Hg 79 Mercury	80 Tl 80 Thallium	81 Pb 81 Lead	82 Bi 82 Bismuth	83 Po 83 Polonium	84 At 84 Astatine	85 Rn 85 Radon	86 Fr 86 Francium	87 Ra 87 Radium	88 Ac 88 Actinium	89 Th 89 Thorium	90 Pa 90 Protactinium	91 U 91 Uranium	92 Np 92 Neptunium	93 Pu 93 Plutonium	94 Am 94 Americium	95 Cm 95 Curium	96 Bk 96 Berkelium	97 Cf 97 Californium	98 Es 98 Einsteinium	99 Fm 99 Fermium	100 Md 100 Mendelevium	101 No 101 Nobelium	102 Lr 102 Lawrencium

The volume of one mole of any gas is 24 dm³ at room temperature and pressure (r.t.p.)

Key X = relative atomic mass
Z = atomic symbol
P = proton (atomic) number

*89-90 Lanthanoid series
91-103 Actinoid series



SINGAPORE CHINESE GIRLS' SCHOOL
Preliminary Examination
Secondary Four

CANDIDATE
NAME

- - - - -

CLASS

4		
---	--	--

REGISTER
NUMBER

--	--

CENTRE
NUMBER

--	--	--	--

INDEX NUMBER

--	--	--	--

Chemistry

5073/02

Paper 2 Theory

Tuesday

28 July 2015

1 hour 45 minutes

Candidates answer on the Question Paper.

No Additional materials are required.

READ THESE INSTRUCTIONS FIRST

Write your class, index number and name on all the work you hand in.

Write in dark blue or black pen.

You may use a soft pencil for any diagrams or graphs.

Do not use staples, paper clips, highlighters, glue or correction fluid/tape.

Section A

Answer all questions in the spaces provided.

Section B

Answer all questions, the last question is in the form either/or.

Answer all questions in the spaces provided.

At the end of the examination, fasten all your work securely together.

The number of marks is given in brackets [] at the end of each question or part question.

A copy of the Periodic Table is printed on page 22

The use of an approved scientific calculator is expected, where appropriate.





For Examiner's Use	
Section A	50
B8	12
B9	8
B10	10
Total	80

Section A

Answer all questions in this section in the spaces provided.
The total mark for this section is 50.

A1 Four of the gases found in air are nitrogen, oxygen, argon and carbon dioxide

(a) Draw straight lines which correctly match the gases and the descriptions shown on the right.

Gases	Description
nitrogen	 relative mass=32
oxygen	 relative mass=40
argon	 relative mass=44
carbon dioxide	 relative mass=28

[2]

(b) Study the 6 statements below. Put a tick (✓) in the box if the statement is true.

Air is a mixture.

All gases in air are elements.

The components in air are only made up of non-metals.

There are weak attractions between the molecules in air.

The gases in air have high melting and boiling points.

Liquid air does not have a fixed boiling point.

[2]

[Total: 4]

A2 The diagram below shows the main parts of an electric motor.

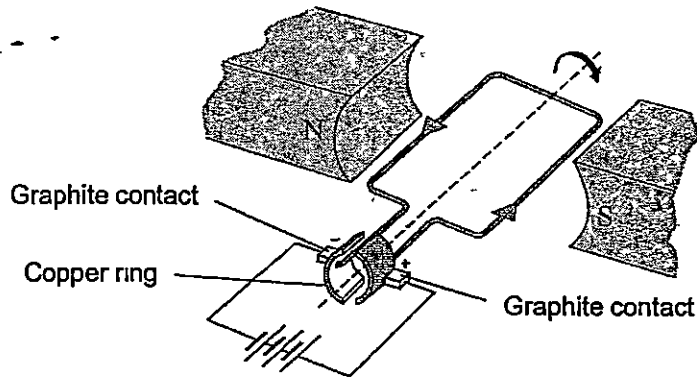

Graphite contacts are used to conduct electricity to the copper ring. When electricity passes through the wires, the copper ring rotates rapidly, turning the motor which is connected to the drill bit. The ring does not get stuck or become worn out.

(a) Explain, in terms of structure and bonding, why copper and graphite are able to conduct electricity.

(i) copper

.....

.....

..... [2]

(ii) graphite

.....

.....

..... [2]

(b) Explain why the copper ring does not become worn out easily though it is in constant contact with the graphite during rotation.

.....

.....

..... [2]

[Total: 6]

A3 A student carries out some tests on an unknown solution P which is known to contain 2 metallic cations and 1 anion. She recorded her observations and deductions in the table shown below.

Expt No.	Procedure	Observations	Deductions
1a	To a solution of P, add sodium hydroxide solution.	White ppt formed	Pb^{2+} , Zn^{2+} , Ca^{2+} or Fe^{2+} could be present
1b	Add excess sodium hydroxide solution into the test tube	Ppt decreased by approximately half Remaining ppt is insoluble in excess sodium hydroxide	Ca^{2+} is present
2	Add Devarda's alloy to the mixture in expt 1b. Warm the mixture	Gas evolved turns moist red litmus blue	Cl^- is present
3a	To new sample of solution P, add aqueous ammonia.	White ppt formed	Al^{3+} , Pb^{2+} or Zn^{2+} could be present
3b	Add excess aqueous ammonia solution into the test tube.	White ppt insoluble in excess aqueous ammonia	Al^{3+} or Pb^{2+} could be present

(a) The student made 3 mistakes in her deductions. In the table below, state the experiment number in which the mistakes were made. Briefly explain your answer.

	Expt No.	Explanation
Mistake 1		
Mistake 2		
Mistake 3		

[3]

(b) Describe a simple test to differentiate between aluminium ions (Al^{3+}) and lead(II) ions (Pb^{2+}).

.....

[2]

[Total: 5]

5

For
Examiner's
Use

- A4 The rate of reaction between hydrochloric acid and excess marble chips (calcium carbonate) was investigated at a temperature of 40°C using the apparatus shown in the diagram below.

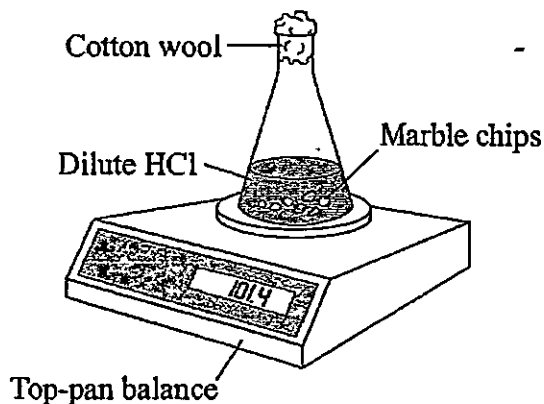

The mass of the flask and contents was measured every half minute for ten minutes. The data obtained was plotted on a graph shown in the grid below.

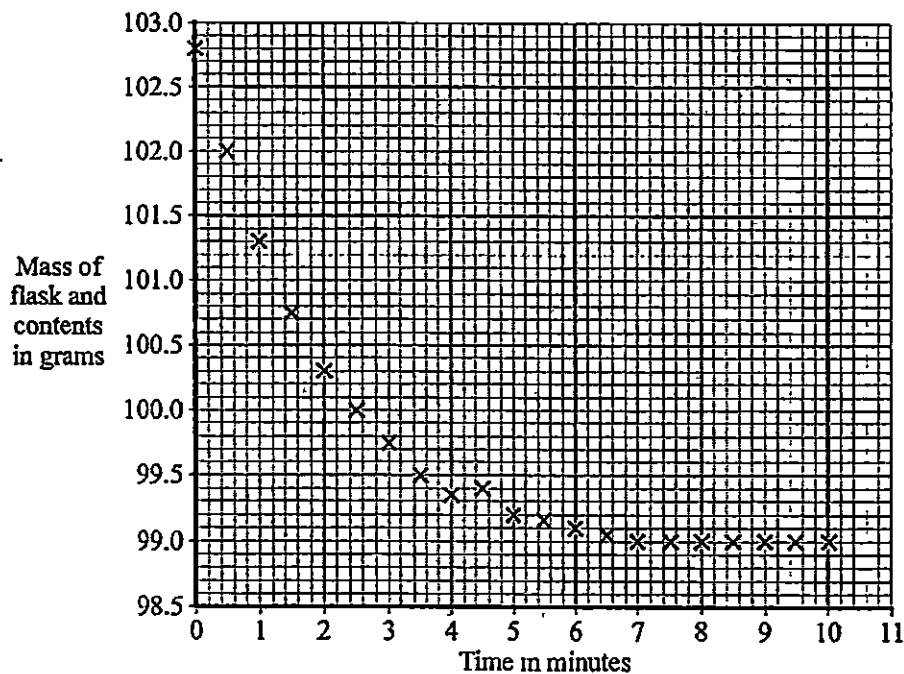

- (a) Complete the graph by drawing a line of best fit. [1]
- (b) Explain why the mass of the flask and contents decreased with time.

.....

..... [1]

7

For
Examiner's
Use

- A5 One method of manufacturing hydrogen is to pass methane and steam over heated nickel catalyst, a process called steam reforming.

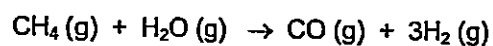

- (a) Using the bond energies listed in the table below, calculate the enthalpy change (ΔH) of this reaction.

Bond	Bond energy (kJ/mol)
H-H	436
C-H	410
O-H	460
C-C	350
C≡O	1046

[3]

- (b) Using your answer to part (a), draw the energy profile diagram using the axes given below, showing the activation energy and the enthalpy change clearly.

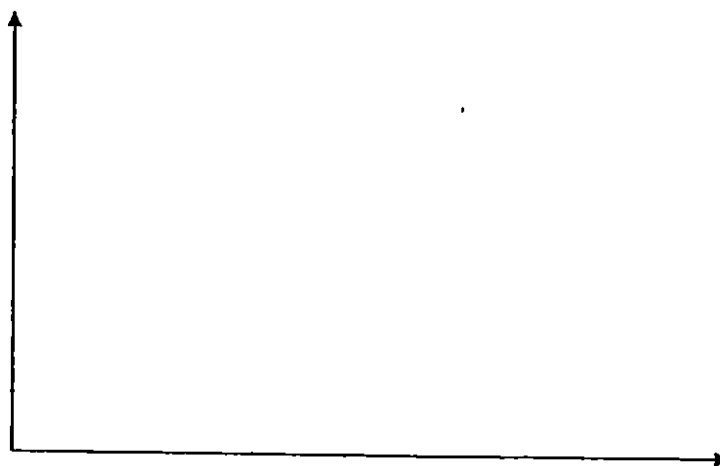

[3]

(c) State whether this is an endothermic or exothermic reaction. Explain your answer in terms of bond breaking and bond forming.

.....

.....

.....

.....

.....

[2]

[Total: 8]

A6 The diagram below shows a food label describing the nutritional content of a packet of crackers.

Nutrition Facts	
Serving Size	5 Crackers (16g)
Servings Per Container	About 14
Amount Per Serving	
Calories 80	Calories from Fat 35
% Daily Values*	
Total Fat 4g	6%
Saturated Fat 0.5g	3%
Trans Fat 0g	
Polyunsaturated Fat 2g	
Monounsaturated Fat 1g	
Cholesterol 0mg	0%
Sodium 150mg	6%
Total Carbohydrate 10g	3%

From the food label, it can be seen that the cracker contains both saturated and unsaturated fat.

(a) Describe a simple chemical test to differentiate between saturated fat and unsaturated fat.

.....

[2]

(b) Describe the main difference in structure between monounsaturated fat and polyunsaturated fat.

.....

[1]

Saturated fats are linked to heart problems. In order to be able to claim that their crackers are healthy, the manufacturer decides to use a vegetable oil which has a higher unsaturated fat content. In a test to determine what kind of vegetable oil is healthier, a laboratory investigation was carried out.

20 cm³ of different vegetable oils were titrated with bromine solution of concentration 0.50 mol/dm³. The results are shown in the table on page 10.

10

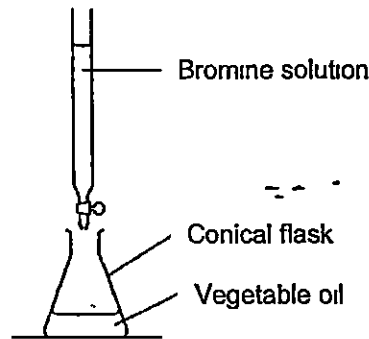

Vegetable oil	Initial burette reading (cm ³)	Final burette reading (cm ³)	Volume of bromine solution used (cm ³)
Palm	0.2	13.7	
Peanut	0.2	12.6	
Soya	0.1	14.4	
Sunflower	0.5	18.9	

(c) Complete the table above. [1]

(d) What colour change in the conical flask would be observed at the end point of the titration?

From to [1]

(e) Which is the healthiest vegetable oil to use to manufacture the crackers? Explain your answer.

Healthiest vegetable oil :

Reason

.....

.....

..... [2]

(f) Unsaturated vegetable oils can be hardened to make margarine. Describe how this process is carried out.

.....

.....

..... [2]

[Total: 9]

11

For
Examiner's
Use

A7 The diagram below shows the structure of an ester molecule M.

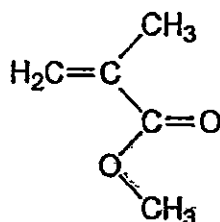

- (a) Circle clearly on the above diagram the group of atoms which makes this molecule an ester. [1]

When M is reacted with water under reflux in the presence of a catalyst, an alcohol and a carboxylic acid are formed.

- (b) Draw the structures of the 2 products formed.

Product 1

Product 2

[2]

When M undergoes polymerization, a polymer called Perspex is formed.

- (c) What type of polymer is Perspex? Give a reason for your answer.

Type of polymer :

Reason :

[2]

- (d) Draw the structure of Perspex, showing two repeat units.

[1]

[Total: 6]

Section B

Answer all three questions in this section.

The last question is in the form of an either/or and only one of the alternatives should be attempted.

- B8** The Haber process, also called the Haber–Bosch process, is an artificial nitrogen fixation process and is the main industrial procedure for the production of ammonia today. It converts atmospheric nitrogen to ammonia by reacting it with hydrogen. Named after its inventors, German chemists Fritz Haber and Carl Bosch, who developed it in the first half of the twentieth century, the Haber process provided Germany with a source of ammonia for the production of explosives during World War I. Today, the ammonia is mainly used to produce fertilisers.

The diagram below shows how a modern ammonia manufacturing plant looks like.

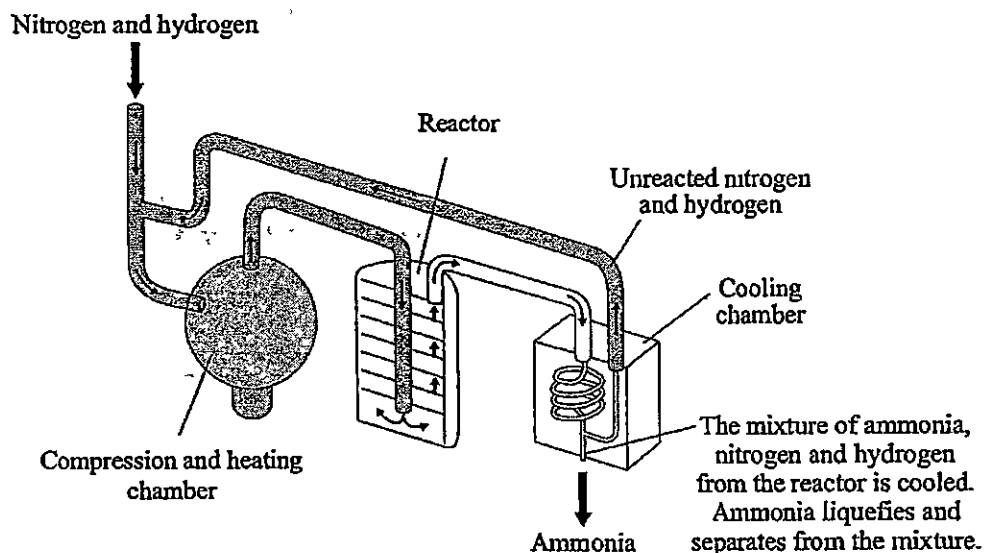

The yield of ammonia can vary, depending on the temperature and pressure. The table below shows the percentage yield under different conditions.

Pressure (atm)	Temperature (°C)					
	100	200	300	400	500	600
10	-	50.7	14.7	3.9	1.2	0.2
25	91.7	63.6	27.4	8.7	2.9	-
50	94.5	74.0	39.5	15.3	5.6	1.1
100	96.7	81.7	52.5	25.2	10.6	2.2
200	98.4	89.0	66.7	38.8	18.3	-
400	99.4	94.6	79.7	55.4	31.9	-
1000	-	98.3	92.6	79.8	57.5	12.9

13

- (a) Write the equation (including state symbols) for the reaction between nitrogen and hydrogen in the Haber Process.

..... [1]

- (b) State the main source of nitrogen and the process by which it is obtained.

..... [1]

- (c) Suggest why air is not used in the Haber process although 78% of air is nitrogen.

.....
 [1]

- (d) The reactant gases are passed through a substance in the reactor. Name this substance and state its function.

Substance : [1]

Function : [1]

- (e) From the information in the table, describe how temperature and pressure affects the yield of ammonia

.....

 [2]

- (f) A particular ammonia plant uses a temperature of 400°C and pressure of 200 atm. Using the information in the table, calculate the mass of ammonia formed when 210 tonnes of nitrogen are reacted.

[2]

- (g) The gases that leave the reactor still contain nitrogen. One reason for this is that nitrogen is a relatively inert gas. Explain this property of nitrogen in terms of its bonding.

.....

.....

.....

.....

.....

..... [2]

- (h) The boiling points of nitrogen, hydrogen and ammonia are as follows :

Gas	Boiling point
nitrogen	-196°C
hydrogen	-253°C
ammonia	-33°C

Suggest a suitable temperature that the cooling chamber must have to be able to function effectively.

Temperature of cooling chamber : [1]

[Total: 12]

B9 The vertical columns in the Periodic Table are called Groups.

(a) Lithium is the first element in Group I.

Describe what you will observe when a piece of lithium is put into water.

.....

.....

.....

.....

..... [2]

(b) Fluorine is the first element in Group VII.

Describe and explain what you will observe when fluorine is bubbled in aqueous sodium iodide.

.....

.....

.....

.....

..... [2]

(c) Lithium reacts with fluorine to form lithium fluoride which melts at 845°C .

(i) Draw the 'dot and cross' diagram to show the bonding in lithium fluoride.

17

EITHER

B10 A student carried out the electrolysis of two equal volumes of silver nitrate solutions of the same concentration using platinum electrodes as shown in the diagram below.

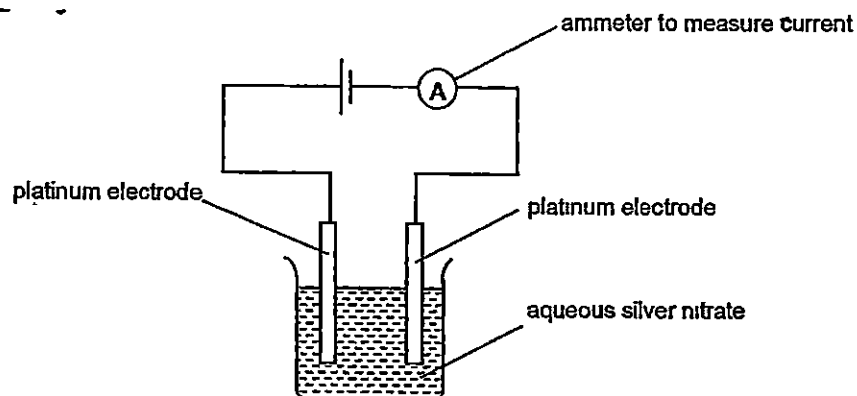

In Experiment 1, a current of 1.0 ampere was used and the mass of one of the electrodes was weighed every 5 minutes to determine the mass of the silver deposited. This was done for 60 minutes. The results in the following table are plotted on the grid on page 18.

Time (min)	0	5	10	15	20	25	30	35	40	45	50
Mass of silver deposited (g)	0	0.30	0.60	0.90	1.20	1.50	1.80	2.10	2.40	2.80	2.80

In Experiment 2, the student repeated the procedure using the same volume of aqueous silver nitrate solution but he increased the current to 1.5 amperes instead. The results are shown in the following table.

Time (min)	0	5	10	15	20	25	30	35	40	45	50
Mass of silver deposited (g)	0	0.45	0.90	1.35	1.80	2.25	2.70	?	2.80	2.80	2.80

- (a) Name the electrode that was weighed in the experiment. Write the equation for the reaction which takes place at this electrode

Electrode :

Equation [2]

- (b) Plot the graph of mass of silver deposited against time for Experiment 2 on the same grid on page 18. Label the graph "Experiment 2" clearly.

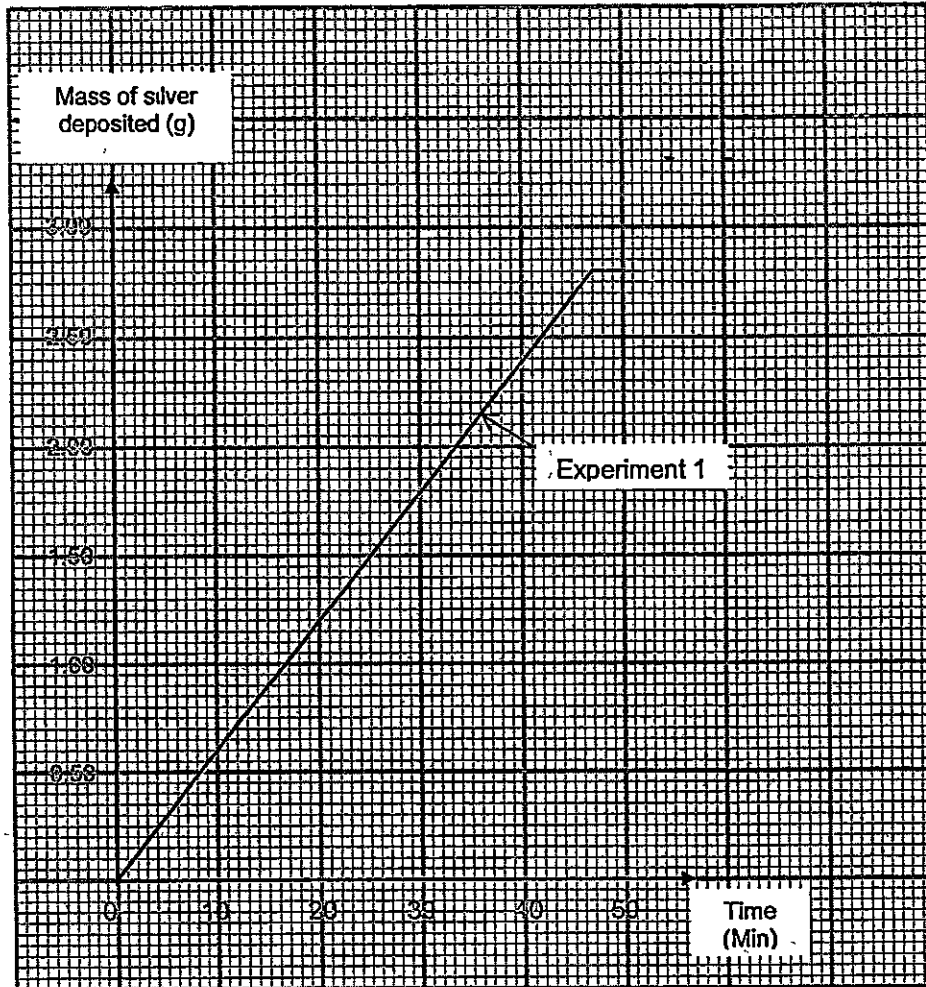

[1]

- (c) Determine the mass of silver deposited after 35 minutes for the second experiment

..... [1]

- (d) State two conclusions from the results of the experiments.

.....

.....

.....

.....

.....

[2]

19

- (e) State a change in the electrolyte at the end of the electrolysis of the two silver nitrate solutions.

..... [1]

- (f) If the electrolyte were replaced by copper(II) sulfate solution and the same current of 1 ampere was passed through, calculate the mass of copper deposited at the end of 40 minutes.

[3]

[Total: 10]

OR

B10 The diagram below shows an experimental set-up of a simple cell and an electrolytic cell. Both electrodes X and Y are made of graphite. The switch is then closed and reactions take place in both cells.

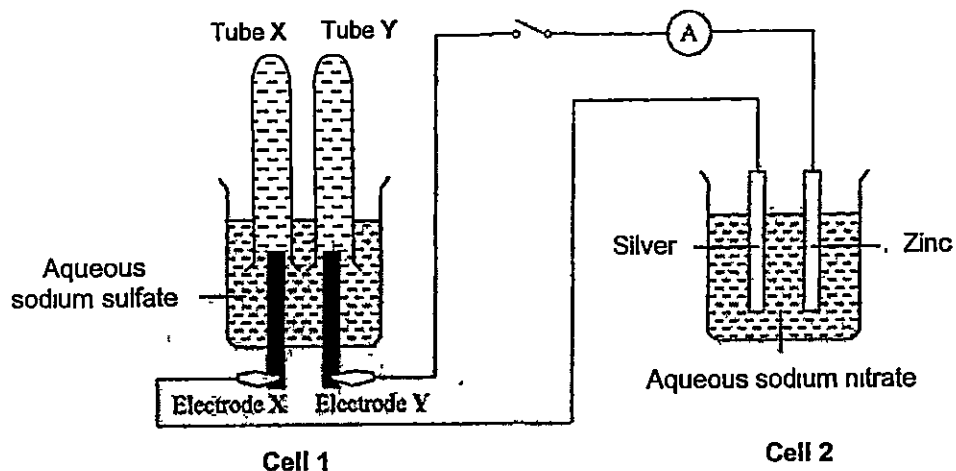

(a) Which is the simple cell? Explain your answer.

Simple Cell : Cell [1]

Explanation :

.

. [1]

(b) Write the ionic equations for the reactions which take place at the electrodes of Cell 1.

Electrode X : [1]

Electrode Y : [1]

- (c) Complete the diagram below to show the new levels of the aqueous sodium sulfate solution after the switch is closed for a while and hence the relative volumes of gases collected in tube X and tube Y. Label clearly the gases collected in each tube [2]

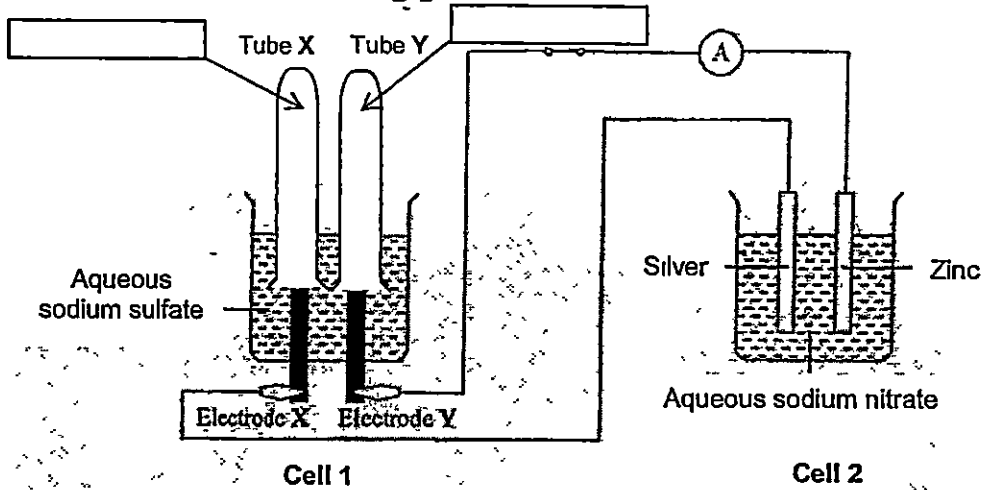

- (d) Electrode X is then replaced by a copper rod. State an observation and explain your answer.

Observation : [1]

Explanation :

..... [1]

- (e) State and explain an observation that can be made in Cell 2 during the experiment.

Observation : [1]

Explanation :

..... [1]

[Total: 10]

DATA SHEET
The Periodic Table of the Elements

Group																		
I	II	III	IV	V	VI	VII	0											1 H Hydrogen
1 Li Lithium	2 Be Beryllium											3 B Boron	4 C Carbon	5 N Nitrogen	6 O Oxygen	7 F Fluorine	8 Ne Neon	
9 Na Sodium	10 Mg Magnesium											11 Al Aluminum	12 Si Silicon	13 P Phosphorus	14 S Sulfur	15 Cl Chlorine	16 Ar Argon	
17 K Potassium	18 Ca Calcium	19 Sc Scandium	20 Ti Titanium	21 V Vanadium	22 Cr Chromium	23 Mn Manganese	24 Fe Iron	25 Co Cobalt	26 Ni Nickel	27 Cu Copper	28 Zn Zinc	29 Ga Gallium	30 Ge Germanium	31 As Arsenic	32 Se Selenium	33 Br Bromine	34 Kr Krypton	
35 Rb Rubidium	36 Sr Strontium	37 Y Yttrium	38 Zr Zirconium	39 Nb Niobium	40 Mo Molybdenum	41 Tc Technetium	42 Ru Ruthenium	43 Rh Rhodium	44 Pd Palladium	45 Ag Silver	46 Cd Cadmium	47 In Indium	48 Sn Tin	49 Sb Antimony	50 Te Tellurium	51 I Iodine	52 Xe Xenon	
53 Cs Cesium	54 Ba Barium	55 La Lanthanum	56 Hf Hafnium	57 Ta Tantalum	58 W Tungsten	59 Re Rhenium	60 Os Osmium	61 Ir Iridium	62 Pt Platinum	63 Au Gold	64 Hg Mercury	65 Tl Thallium	66 Pb Lead	67 Bi Bismuth	68 Po Polonium	69 At Astatine	70 Rn Radon	
71 Fr Francium	72 Ra Radium	73 Ac Actinium																

86-71 Lanthanoid series
90-103 Actinoid series

Key
X = atomic symbol
s = relative atomic mass
p = proton (atomic) number

The volume of one mole of any gas is 24 dm³ at room temperature and pressure (r.t.p.)

71 Lu Lutetium	72 Yb Ytterbium	73 Tm Thulium	74 Er Erbium	75 Ho Holmium	76 Dy Dysprosium	77 Tb Terbium	78 Gd Gadolinium	79 Eu Europium	80 Sm Samarium	81 Pm Promethium	82 Nd Neodymium	83 Pr Praseodymium	84 Pa Protactinium	85 Th Thorium	86 U Uranium	87 Np Neptunium	88 Pu Plutonium	89 Am Americium	90 Cm Curium	91 Bk Berkelium	92 Cf Californium	93 Es Einsteinium	94 Fm Fermium	95 Md Mendelevium	96 No Nobelium	97 Lr Lawrencium
----------------------	-----------------------	---------------------	--------------------	---------------------	------------------------	---------------------	------------------------	----------------------	----------------------	------------------------	-----------------------	--------------------------	--------------------------	---------------------	--------------------	-----------------------	-----------------------	-----------------------	--------------------	-----------------------	-------------------------	-------------------------	---------------------	-------------------------	----------------------	------------------------

Answers for SCGS Preliminary Examination Chemistry P1 2015

1-5	D	D	D	A	D
6-10	C	A	B	D	C
11-15	A	A	C	D	B
16-20	D	C	B	C	D
21-25	C	A	A	C	A
26-30	C	A	D	B	B
31-35	A	C	C	A	C
36-40	B	A	B	B	A



SINGAPORE CHINESE GIRLS' SCHOOL
Preliminary Examination
Secondary Four

CANDIDATE
NAME

--

CLASS

4		
---	--	--

REGISTER
NUMBER

--	--

CENTRE
NUMBER

--	--	--	--

INDEX NUMBER

--	--	--	--

Chemistry

5073/02

Paper 2 Theory

Tuesday

28 July 2015

1 hour 45 minutes

Candidates answer on the Question Paper

No Additional materials are required

READ THESE INSTRUCTIONS FIRST

Write your class, index number and name on all the work you hand in

Write in dark blue or black pen

You may use a soft pencil for any diagrams or graphs

Do not use staples, paper clips, highlighters, glue or correction fluid/tape

Section A

Answer all questions in the spaces provided

Section B

Answer all questions, the last question is in the form either/or.

Answer all questions in the spaces provided

At the end of the examination, fasten all your work securely together

The number of marks is given in brackets [] at the end of each question or part question

A copy of the Periodic Table is printed on page 22

The use of an approved scientific calculator is expected, where appropriate

Answers





For Examiner's Use	
Section A	50
B8	12
B9	8
B10	10
Total	80

Section A

Answer all questions in this section in the spaces provided
The total mark for this section is 50

A1 Four of the gases found in the air are nitrogen, oxygen, argon and carbon dioxide

- (a) Draw straight lines which correctly match the gases and the descriptions shown on the right.

Gases	Description
nitrogen	 relative mass = 32
oxygen	 relative mass = 40
argon	 relative mass = 44
carbon dioxide	 relative mass = 28

1 correct – 0m
2 correct – 1m
3 correct – 1m
4 correct – 2m

[2]

- (b) Study the 6 statements below. Put a tick (✓) in the box if the statement is true

Air is a mixture.

All gases in air are elements.

The components in air are only made up of non-metals

There are weak attractions between the molecules in air

The gases in air have high melting and boiling points

Liquid air does not have a fixed boiling point.

[2]

If 4 ticks or less, ignore wrong ticks

1 correct – 0m

2 correct – 1m

3 correct – 1m

4 correct – 2m

If 5 ticks or more, 1m

[Total 4]

A2 The diagram below shows the main parts of an electric motor

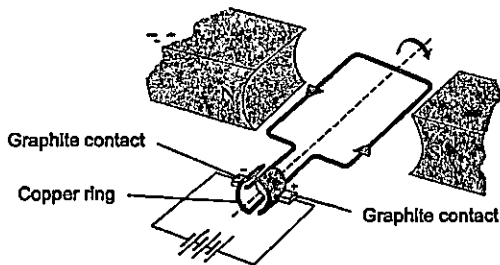

Graphite contacts are used to conduct electricity to the copper ring. When electricity passes through the wires, the copper ring rotates rapidly, turning the motor which is connected to the drill bit. The ring does not get stuck or become worn out.

- (a) Explain, in terms of structure and bonding, why copper and graphite are able to conduct electricity.

(a) NOT Accepted.
Copper is surrounded by a sea of electrons; Copper has charged particles, Protons in a sea of electrons.

(i) copper

Outer valence electrons of copper atoms are delocalized. 1m

Electrons are mobile and able to move freely within metal lattice. 1m

[2]

(ii) graphite

1 valence electron from each carbon atom are not used for covalent

bonding with other atoms; 1m

these delocalized electrons can move freely along the hexagonal layers. 1m

[2]

- (b) Explain why the copper ring does not become worn out easily though it is in constant contact with the graphite during rotation.

Graphite is soft and slippery; 1m

very little friction between the copper ring and graphite contacts, 1m

[2]

(all) NOT Accepted.

Graphite has 3 valence out of 4 valence electrons involved in bonding (per atom not mentioned); Electrons bonded to each other; One carbon bonded to 3 electrons, 3 out of 4 carbon atoms bonded, leaving one free to conduct electricity; 3 out of 4 valence electrons bonded together, Van der Waals forces between layers so there are free electrons between them. Electrons move between layers.

(b) NOT Accepted
Graphite is soft (no mention of slippery), Copper is hard; Copper layers cannot slide

[Total: 8]

- A3 A student carries out some tests on an unknown solution P which is known to contain 2 metallic cations and 1 anion. She recorded her observations and deductions in the table shown below.

Expt No	Procedure	Observations	Deductions
1a	To a solution of P, add sodium hydroxide solution	White ppt formed	Pb^{2+} , Zn^{2+} , Ca^{2+} or Fe^{2+} could be present
1b	Add excess sodium hydroxide solution into the test tube	Ppt decreased by approximately half Remaining ppt is insoluble in excess sodium hydroxide	Ca^{2+} is present
2	Add Devarda's alloy to the mixture in expt 1b. Warm the mixture.	Gas evolved turns moist red litmus blue	Cl^- is present
3a	To new sample of solution P, add aqueous ammonia	White ppt formed	Al^{3+} , Pb^{2+} or Zn^{2+} could be present
3b	Add excess aqueous ammonia solution into the test tube	White ppt insoluble in excess aqueous ammonia	Al^{3+} or Pb^{2+} could be present

- (a) The student made 3 mistakes in her deductions. In the table below, state the experiment number in which the mistakes were made. Briefly explain your answer.

	Expt No.	Explanation
Mistake 1	1a	Fe^{2+} ions cannot be present as it forms green ppt. 1m
Mistake 2	1a	Aluminium ion (Al^{3+}) should also be a possible ion present as it forms white ppt with aqueous sodium hydroxide. 1m
Mistake 3	2	Nitrate ion (NO_3^-) should be present, not chloride. 1m

[3]

- (b) Describe a simple test to differentiate between aluminium ions (Al^{3+}) and lead(II) ions (Pb^{2+}).

Add aqueous potassium iodide, 1m, only lead(II) ions will give yellow ppt. 1m

OR Add any solution containing chloride or sulfate ions (except of barium), 1m,

only lead(II) ions will give white ppt. 1m

a) Mistake 3 - NOT Accepted :
 Cl^- turns blue litmus red, then bleaches it;
 Gas evolved is not chlorine (Chlorine gas is NOT mentioned; only chloride ion)
 Gas is NH_4^+ which turns red litmus blue,
 ion should be NH_4^+ , NH_3 , NO_3^-

a) accept Expt 1 b
 This means that Al^{3+} or Pb^{2+} may be present together with Ca^{2+}
 b) Displacement method, partial mark if explained correctly; Not accepted -- use of barium chloride solution

[2]

(Total 5)

- A4 The rate of reaction between hydrochloric acid and excess marble chips (calcium carbonate) was investigated at a temperature of 40°C using the apparatus shown in the diagram below

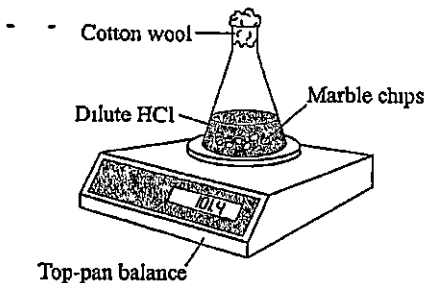

The mass of the flask and contents was measured every half minute for ten minutes. The data obtained was plotted on a graph shown in the grid below.

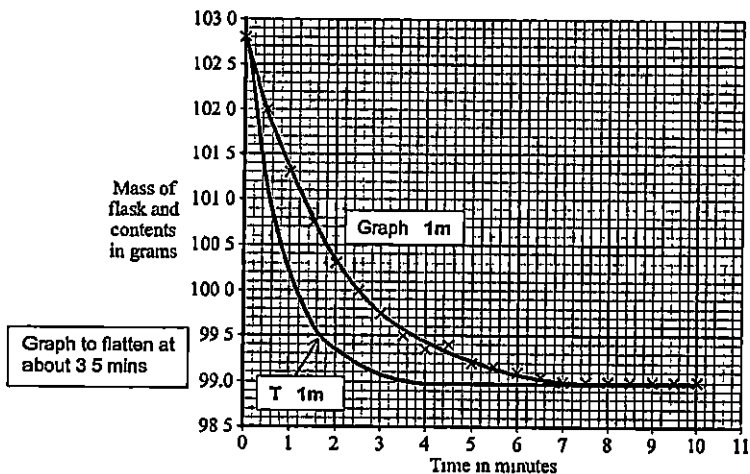

- (a) Complete the graph by drawing a line of best fit. [1]
 (b) Explain why the mass of the flask and contents decreased with time.

Carbon dioxide gas produced during the reaction escapes 1m

- b) Explanation must convey loss of carbon dioxide gas from flask to the surroundings [1]

- (c) State the time taken for the reaction to complete

7 minutes 1m

Reject all other answers

[1]

- (d) A student repeated the experiment but forgot to place the cotton wool at the neck of the conical flask. State how his results would be different and explain your answer

Mass readings will be lower than the actual mass. 1mWithout the cotton wool, some acid will be lost as acid spray. 1m

[2]

- (e) Given that 40 cm
- ³
- of hydrochloric acid were used in the reaction, calculate the concentration of this acid in mol/dm
- ³



Mass of carbon dioxide produced = 102.8 g - 99.0 g = 3.8 g

No of moles of carbon dioxide produced = $\frac{3.8}{44}$ moles = 0.086364 mole 1m

2 moles of hydrochloric acid produces 1 mole of carbon dioxide

Hence, no of moles of hydrochloric acid present = 2 x 0.086364 moles
= 0.17273 moles 1mHence, concentration of hydrochloric acid = $\frac{0.17273}{0.04}$ = 4.32 mol/dm³ 1m

[3]

Another student repeated the first experiment at a temperature of 50°C. All other variables were kept the same.

- (f) On the same grid on page 5, draw the graph she can expect to obtain for this experiment. Label this graph T. [1]

- (g) Explain, in terms of the collision theory, how an increase in temperature affects the rate of reaction

Particles gain kinetic energy and move faster, orMore particles possess energy equal or greater than the activation energy. 1mFrequency of collisions increases, number of effective collisions increasesper unit time. 1mrate of reaction increases 1m

[3]

[Total 12]

Only answered 1st
part correctly (no
explanation) 1m,
Correct answer but
wrong/absurd
reasoning 1mECF Max mark
1/3

- A5 One method of manufacturing hydrogen is to pass methane and steam over heated nickel catalyst, a process called steam reforming



- (a) Using the bond energies listed in the table below, calculate the enthalpy change (ΔH) of this reaction

No statements and wrong answer - 0m, minus 1m for no units or sign
If statements/concepts correct but calculation wrong, max 1m

Bond	Bond energy (kJ/mol)
H-H	436
C-H	410
O-H	460
C-C	350
C≡O	1046

Energy taken in to break bonds in reactants

4 C-H bonds in methane = $4 \times 410 = +1640 \text{ kJ}$

2 O-H bonds in water = $2 \times 460 = +920 \text{ kJ}$

Total energy taken in = $+1640 + 920 = +2560 \text{ kJ}$ 1m

Energy released when bonds are formed in products.

1 C≡O bond = $1 \times 1046 = -1046 \text{ kJ}$

3 H-H = $3 \times 436 = -1308 \text{ kJ}$

Total energy released = $-1046 - 1308 = -2354 \text{ kJ}$ 1m

Hence, ΔH for reaction = $+2560 - 2354 = +206 \text{ kJ}$ 1m

[3]

- (b) Using your answer to part (a), draw the energy profile diagram using the axes given below, showing the activation energy and the enthalpy change clearly

ECF If Part a ΔH wrong but all parts correct in part b, max 3m
Reject terms such as energy needed, required for both bond-making/breaking processes

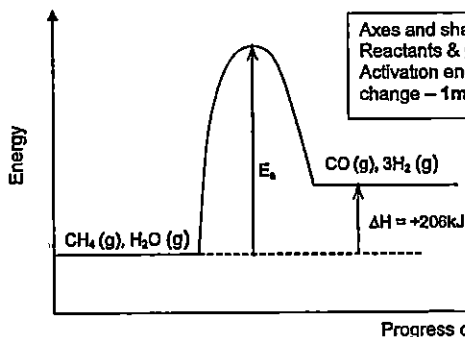

[3]

- (c) State whether this is an endothermic or exothermic reaction Explain your answer in terms of bond breaking and bond forming

Energy taken in to break the bonds in methane and steam is greater than energy released when bonds are formed in carbon monoxide and hydrogen.

(or vice versa) hence it is an endothermic reaction

Energy taken in to break the bonds in reactants and energy released when bonds are formed in products – 1m
Greater/lesser and endothermic reaction – 1m

[2]

[Total 8]

- A6 The diagram below shows a food label describing the nutritional content of a packet of crackers

Nutrition Facts	
Serving Size	5 Crackers (16g)
Servings Per Container	About 14
Amount Per Serving	
Calories 80	Calories from Fat 35
% Daily Value*	
Total Fat 4g	6%
Saturated Fat 0.5g	1%
Trans Fat 0g	0%
Cholesterol 0mg	0%
Sodium 150mg	6%
Total Carbohydrate 10g	3%

From the food label, it can be seen that the cracker contains both saturated and unsaturated fat.

- (a) Describe a simple chemical test to differentiate between saturated fat and unsaturated fat.

Add aqueous bromine into the sample of fat and shake, 1m

Unsaturated fat will decolourise the reddish brown bromine, no visible change with saturated fat (Bromine remains brown) 1m

[2]

- (b) Describe the main difference in structure between monounsaturated fat and polyunsaturated fat.

Monounsaturated fat has one carbon-carbon double bond per molecule compared to polyunsaturated which has many carbon-carbon double bonds in the molecules (or vice versa) 1m

[1]

Saturated fats are linked to heart problems. In order to be able to claim that their crackers are healthy, the manufacturer decides to use a vegetable oil which has a higher unsaturated fat content. In a test to determine what kind of vegetable oil is healthier, a laboratory investigation was carried out.

20 cm³ of different vegetable oils were titrated with bromine solution of concentration 0.50 mol/dm³. The results are shown in the table on page 10

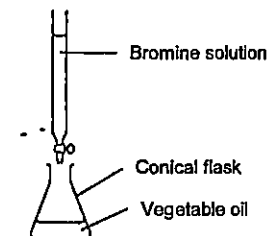

Vegetable oil	Initial burette reading (cm ³)	Final burette reading (cm ³)	Volume of bromine solution used (cm ³)
Palm	0.2	13.7	13.5
Peanut	0.2	12.6	12.4
Soya	0.1	14.4	14.3
Sunflower	0.5	18.9	18.4

- (c) Complete the table above All values correct – 1m [1]
- (d) What colour change in the conical flask would be observed at the end point of the titration?
From pale yellow/colourless to light brown (Both colours correct 1m) [1]
- (e) Which is the healthiest vegetable oil to use to manufacture the crackers? Explain your answer.
Healthiest vegetable oil . Sunflower oil . 1m
Reason Sunflower oil needs the highest volume of bromine solution to react with
it completely, suggesting that sunflower oil is most unsaturated (has the largest
number of carbon-carbon double bonds . 1m
- [2]
- (f) Unsaturated vegetable oils can be hardened to make margarine. Describe how this process is carried out.
Carry out hydrogenation (or react vegetable oil with hydrogen), 1m
at temperature of 200°C and nickel catalyst 1m

[2]

[Total 9]

A7 The diagram below shows the structure of an ester molecule M

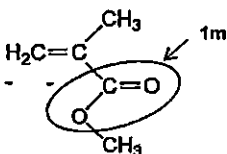

- (a) Circle clearly on the above diagram the group of atoms which makes this molecule an ester. [1]

When M is reacted with water under reflux in the presence of a catalyst, an alcohol and a carboxylic acid are formed

- (b) Draw the structures of the 2 products formed

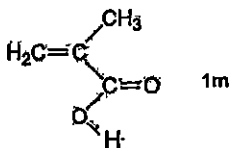

Product 1

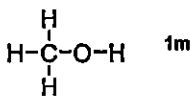

Product 2

[2]

When M undergoes polymerization, a polymer called Perspex is formed

- (c) What type of polymer is Perspex? Give a reason for your answer.

Type of polymer : Addition polymer 1m

Reason . M has a carbon-carbon double bond which allows addition [2]

polymerization to take place 1m

- (d) Draw the structure of Perspex, showing two repeat units

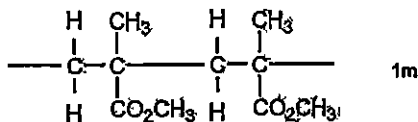

[1]

[Total 6]

Section B

Answer all three questions in this section

The last question is in the form of an either/or and only one of the alternatives should be attempted

- B8** The Haber process, also called the Haber–Bosch process, is an artificial nitrogen fixation process and is the main industrial procedure for the production of ammonia today. It converts atmospheric nitrogen to ammonia by reacting it with hydrogen. Named after its inventors, German chemists Fritz Haber and Carl Bosch, who developed it in the first half of the twentieth century, the Haber process provided Germany with a source of ammonia for the production of explosives during World War I. Today, the ammonia is mainly used to produce fertilisers.

The diagram below shows how a modern ammonia manufacturing plant looks like

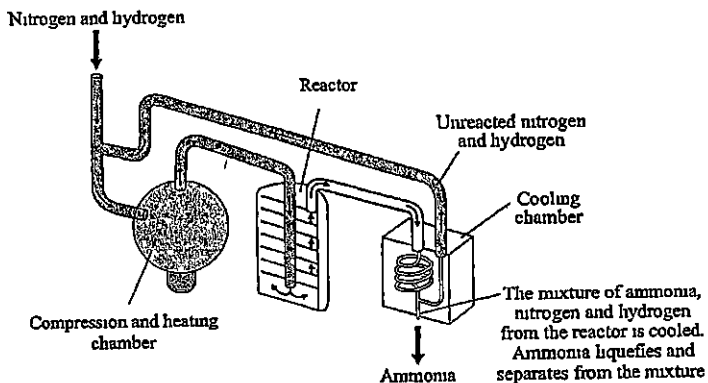

The yield of ammonia can vary, depending on the temperature and pressure. The table below shows the percentage yield under different conditions

Pressure (atm)	Temperature (°C)					
	100	200	300	400	500	600
10	-	50.7	14.7	3.9	1.2	0.2
25	91.7	63.6	27.4	8.7	2.9	-
50	94.6	74.0	39.5	15.3	5.6	1.1
100	96.7	81.7	52.5	25.2	10.6	2.2
200	98.4	89.0	66.7	38.8	18.3	-
400	99.4	94.6	79.7	55.4	31.9	-
1000	-	98.3	92.6	79.8	57.5	12.9

- (a) Write the equation (including state symbols) for the reaction between nitrogen and hydrogen in the Haber Process

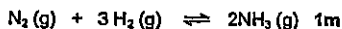

- (b) State the main source of nitrogen and the process by which it is obtained

Fractional distillation of liquid air 1m [1]

- (c) Suggest why air is not used in the Haber process although 78% of air is nitrogen

Oxygen in the air will react with the hydrogen at high temperature and lower the yield of ammonia 1m [1]

- (d) The reactant gases are passed through a substance in the reactor. Name this substance and state its function

Substance Finely divided iron 1m [1]

Function Catalyst to speed up reaction 1m [1]

- (e) From the information in the table, describe how temperature and pressure affects the yield of ammonia

The higher the temperature, the lower the yield 1m

The higher the pressure the higher the yield 1m

..... [2]

- (f) A particular ammonia plant uses a temperature of 400°C and pressure of 200 atm. Using the information in the table, calculate the mass of ammonia formed when 210 tonnes of nitrogen are reacted

From mass ratio of equation, 28 units of nitrogen yields 34 units of ammonia

Hence, 210 tonnes of nitrogen yield = $\frac{34}{28} \times 210 = 255$ tonnes of ammonia 1m

From table, the yield at 400°C and 200 atm is 38.8%

Hence, the mass of ammonia formed = $\frac{38.8}{100} \times 255 = 98.94$ tonnes of ammonia
= 98.9 tonnes (3 s.f.) 1m

- (g) The gases that leave the reactor still contain nitrogen. One reason for this is that nitrogen is a relatively inert gas. Explain this property of nitrogen in terms of its bonding.

Nitrogen is a very inert/unreactive gas,

Each nitrogen molecule has 3 covalent bonds joining 2 nitrogen atoms, 1m

a lot of energy is required to break these bonds 1m

.. . . .

[2]

- (h) The boiling points of nitrogen, hydrogen and ammonia are as follows

Gas	Boiling point
nitrogen	-196°C
hydrogen	-253°C
ammonia	-33°C

Suggest a suitable temperature that the cooling chamber must have to be able to function effectively

Temperature of cooling chamber Any temp between -34°C and -196°C 1m [1]

[Total 12]

B9 The vertical columns in the Periodic Table are called Groups

(a) Lithium is the first element in Group I

Describe what you will observe when a piece of lithium is put into water

Lithium darts on the surface, **1m**

Reject skip or jump

sizzling sound, **1m**

sparks **1m** (Any 2 points, 2m)

[2]

(b) Fluorine is the first element in Group VII

Describe and explain what you will observe when fluorine is bubbled in aqueous sodium iodide

Colourless solution turns brown / black precipitate will be seen, **1m**

Fluorine is more reactive than iodine and displaces the iodide ions to form

brown aqueous iodine **1m**

[2]

Iodine is not reddish brown!
Water present so iodine formed in aqueous state not as a purple gas!
NOT fluorine is more reactive than iodide;
NOT iodide ion not iodine ion!

(c) Lithium reacts with fluorine to form lithium fluoride which melts at 845°C

(i) Draw the 'dot and cross' diagram to show the bonding in lithium fluoride

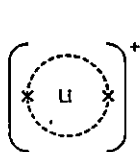

1m

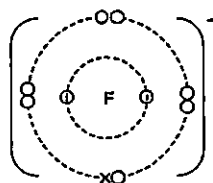

1m

Key

X • Lithium electron

O • Fluorine electron

[2]

(ii) Explain why lithium fluoride has a high melting point.

Lithium fluoride has giant crystal/ionic lattice structure. 1m

Strong electrostatic force of attraction between lithium and fluoride ions.

a lot of energy is required to break force of attraction, hence high m.p. 1m

[2]

[Total 8]

EITHER

B10 A student carried out the electrolysis of 2 equal volumes of silver nitrate solutions of the same concentration using platinum electrodes as shown in the diagram below

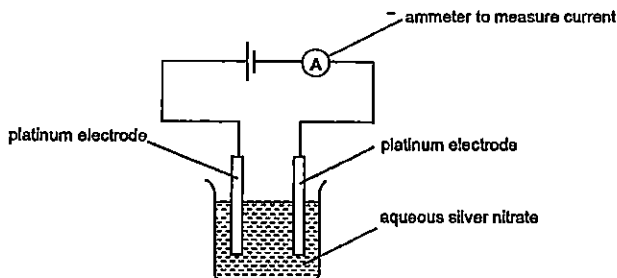

In Experiment 1, a current of 10 ampere was used and the mass of one of the electrodes was weighed every 5 minutes to determine the mass of the silver deposited. This was done for 60 minutes. The results in the following table are plotted on the grid on page 18

Time (min)	0	5	10	15	20	25	30	35	40	45	50
Mass of silver deposited (g)	0	0.30	0.60	0.90	1.20	1.50	1.80	2.10	2.40	2.80	2.80

In Experiment 2, the student repeated the procedure using the same volume of aqueous silver nitrate solution but he increased the current to 1.5 amperes instead. The results are shown in the following table

Time (min)	0	5	10	15	20	25	30	35	40	45	50
Mass of silver deposited (g)	0	0.45	0.90	1.35	1.80	2.25	2.70	?	2.80	2.80	2.80

- (a) Name the electrode that was weighed in the experiment. Write the equation for the reaction which takes place at this electrode

Electrode Cathode 1m

Equation . $\text{Ag}^+(\text{aq}) + \text{e}^- \rightarrow \text{Ag}(\text{s})$ 1m [2]

- (b) Plot the graph of mass of silver deposited against time for Experiment 2 on the same grid on page 18. Label the graph "Experiment 2" clearly

Remark , The tables show an increase in mass of the electrode so this must be the cathode. Silver ions are preferentially discharged to form silver solid on the cathode

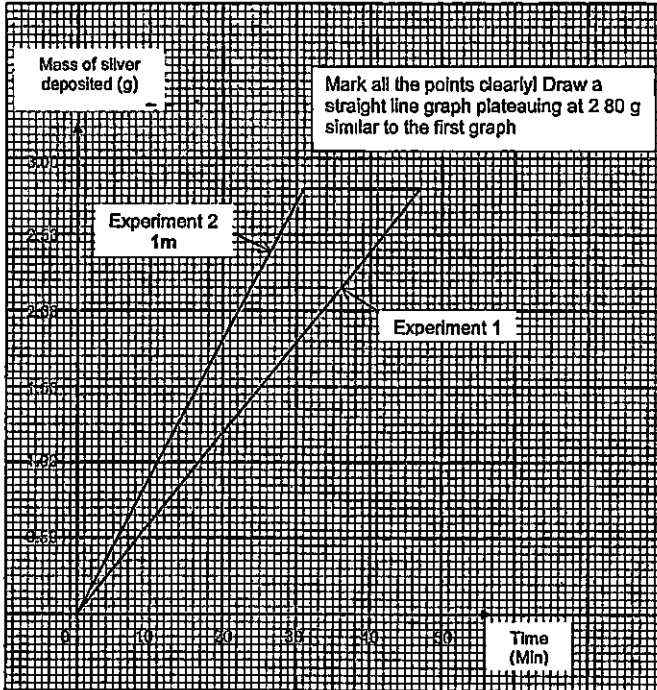

[1]

- (c) Determine the mass of silver deposited after 35 minutes for the second experiment

2.80 g 1m

[1]

- (d) State two conclusions from the results of the experiments

Mass of silver deposited is directly proportional to time, 1m

The larger the current, the faster the rate of the silver deposited 1m OR

An increase in current from 1 ampere to 15 amperes has no effect on the

final mass of silver deposited

[2]

The two experiments involve mass of silver deposited, time and current so conclusions should be specific to these factors and their relationships

Rejected

The final mass of silver for both experiments is 2.80 g (not a conclusion based on experiments but a fact)

An increase in current increases the rate of reaction/ rate of electrolysis (not specific enough)

When the same volume and concentration of solution is used, the mass of silver deposited will be the same (True but not based on experiments, we did not vary volume/concentration to investigate this)

- (e) State a change in the electrolyte at the end of the electrolysis of the two silver nitrate solutions

The electrolyte becomes more acidic or pH decreases 1m OR [1]

Concentration of silver ions decreases 1m

- (f) If the electrolyte were replaced by copper(II) sulfate solution and the same current of 1 ampere was passed through, calculate the mass of copper deposited at the end of 40 minutes

Number of moles of silver deposited = $\frac{2.4}{108}$ mole = 0.022222 mole 1m

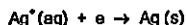

1 mole of silver ions takes in 1 mole of electrons to form 1 mole of silver

Hence, 0.022222 mole of silver has combined with 0.022222 mole of electrons

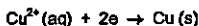

Cu^{2+} ions takes in twice the number of electrons to form 1 mole of copper

Hence, number of moles of copper deposited by 0.022222 mole of electrons

$$= 0.5 \times 0.022222 = 0.011111 \text{ mole } 1\text{m}$$

Mass of copper deposited = 0.011111 x 64 = 0.711 g (3 s f) 1m

Rejected.

Mass of copper deposited = $2.40 / 2 = 1.20 \text{ g}$ (Ratio of masses \neq ratio of moles)

[3]

[Total 10]

OR

B10 The diagram below shows an experimental set-up of a simple cell and an electrolytic cell. Both electrodes X and Y are made of graphite. The switch is then closed and reactions take place in both cells.

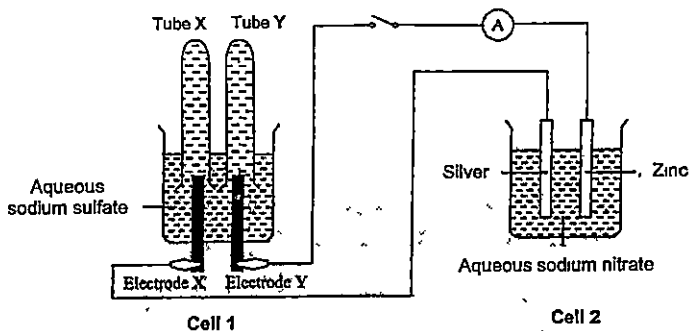

(a) Which is the simple cell? Explain your answer.

Simple Cell: Cell 2 1m

[1]

Explanation: simple cell consists of 2 different metals dipped in electrolyte and not connected to external power supply. Both points 1m

[1]

(b) Write the ionic equations for the reactions which take place at the electrodes of Cell 1.

Electrode X: $4\text{OH}^-(\text{aq}) \rightarrow 2\text{H}_2\text{O}(\text{l}) + \text{O}_2(\text{g}) + 4\text{e}^-$ 1m

[1]

Electrode Y: $2\text{H}^+(\text{aq}) + 2\text{e}^- \rightarrow \text{H}_2(\text{g})$ 1m

[1]

- (c) Complete the diagram below to show the new levels of the aqueous sodium sulfate solution after the switch is closed for a while and hence the relative volumes of gases collected in tube X and tube Y. Label clearly the gases collected in each tube. [2]

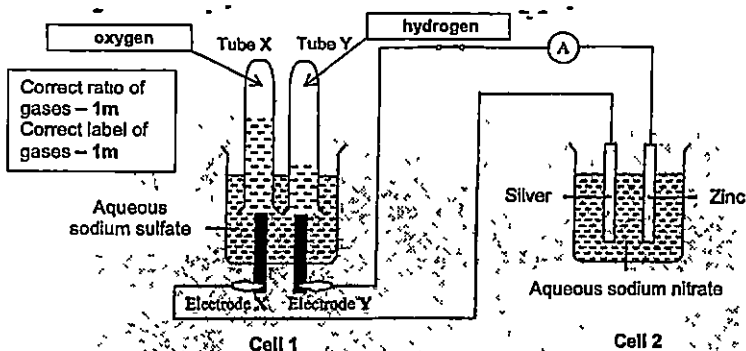

- (d) Electrode X is then replaced by a copper rod. State an observation and explain your answer.

Observation: electrolyte will turn blue OR size of copper decreases 1m [1]

Explanation: Copper electrode (the anode) ionizes to form copper(II) ions which is blue, hence electrolyte turns blue OR copper electrode becomes smaller as copper ionizes 1m [1]

- (e) State and explain an observation that can be made in Cell 2 during the experiment.

Observation: Size of zinc decreases OR bubbles seen at silver electrode 1m [1]

Explanation: zinc, the more reactive metal, ionizes to form zinc ions OR Hydrogen ions accept electrons to form hydrogen gas 1m

[1]

[Total 10]

Rejected

Reddish brown solid deposited on electrode Y (this does not happen immediately, at the beginning effervescence is seen as hydrogen ions are preferentially discharged)

DATA SHEET
The Periodic Table of the Elements

I		II										III	IV	V	VI	VII	0
<div style="position: absolute; top: 10px; left: 40%; border: 1px solid black; padding: 2px;"> 1 H Hydrogen </div>																	2 He Helium
3 Li Lithium 7	4 Be Beryllium 9											5 B Boron 10	6 C Carbon 12	7 N Nitrogen 14	8 O Oxygen 16	9 F Fluorine 19	10 Ne Neon 20
11 Na Sodium 23	12 Mg Magnesium 24											13 Al Aluminum 27	14 Si Silicon 28	15 P Phosphorus 31	16 S Sulfur 32	17 Cl Chlorine 35.5	18 Ar Argon 39.9
19 K Potassium 39	20 Ca Calcium 40	21 Sc Scandium 45	22 Ti Titanium 48	23 V Vanadium 51	24 Cr Chromium 52	25 Mn Manganese 55	26 Fe Iron 56	27 Co Cobalt 59	28 Ni Nickel 59	29 Cu Copper 63.5	30 Zn Zinc 65	31 Ga Gallium 69.5	32 Ge Germanium 72.6	33 As Arsenic 75	34 Se Selenium 79	35 Br Bromine 79.9	36 Kr Krypton 83.8
37 Rb Rubidium 85.5	38 Sr Strontium 87.6	39 Y Yttrium 88.9	40 Zr Zirconium 91.2	41 Nb Niobium 92.9	42 Mo Molybdenum 95.9	43 Tc Technetium 98	44 Ru Ruthenium 101.1	45 Rh Rhodium 102.9	46 Pd Palladium 106.4	47 Ag Silver 107.9	48 Cd Cadmium 112.4	49 In Indium 114.8	50 Sn Tin 118.7	51 Sb Antimony 121.8	52 Te Tellurium 127.6	53 I Iodine 126.9	54 Xe Xenon 131.3
55 Cs Cesium 132.9	56 Ba Barium 137.3	57 La Lanthanum 138.9	58 Ce Cerium 140.1	59 Pr Praseodymium 140.9	60 Nd Neodymium 144.2	61 Pm Promethium 145	62 Sm Samarium 150.4	63 Eu Europium 152	64 Gd Gadolinium 157.3	65 Tb Terbium 158.9	66 Dy Dysprosium 162.5	67 Ho Holmium 164.9	68 Er Erbium 167.3	69 Tm Thulium 168.9	70 Yb Ytterbium 173	71 Lu Lutetium 175	
72 Fr Francium 223	73 Ra Radium 226	74 Ac Actinium 227															75 Rn Radon 222

*58-71 Lanthanoid series
100-103 Actinoid series

Key

a	= relative atomic mass
X	= atomic symbol
b	= proton (atomic) number

72 Fr Francium 223	73 Ra Radium 226	74 Ac Actinium 227	75 Rn Radon 222	76 Po Polonium 209	77 At Astatine 210	78 Bi Bismuth 209	79 Pb Lead 208	80 Tl Thallium 208	81 Pb Lead 208	82 Bi Bismuth 209	83 Po Polonium 209	84 At Astatine 210	85 Fr Francium 223	86 Ra Radium 226	87 Ac Actinium 227	88 Th Thorium 232	89 Pa Protactinium 231	90 U Uranium 238	91 Np Neptunium 237	92 Pu Plutonium 244	93 Am Americium 243	94 Cm Curium 247	95 Bk Berkelium 247	96 Cf Californium 251	97 Es Einsteinium 252	98 Fm Fermium 257	99 Md Mendelevium 258	100 No Nobelium 259	101 Lr Lawrencium 260
-----------------------------	---------------------------	-----------------------------	--------------------------	-----------------------------	-----------------------------	----------------------------	-------------------------	-----------------------------	-------------------------	----------------------------	-----------------------------	-----------------------------	-----------------------------	---------------------------	-----------------------------	----------------------------	---------------------------------	---------------------------	------------------------------	------------------------------	------------------------------	---------------------------	------------------------------	--------------------------------	--------------------------------	----------------------------	--------------------------------	------------------------------	--------------------------------

The volume of one mole of any gas is 24 dm³ at room temperature and pressure (r.t.p.).